

GCSE

Specimen Papers and Mark Schemes

**Edexcel GCSE
Design & Technology: Graphic Products
Full course (1972)**

**For First Examination
Summer 2003**

Edexcel
Success through qualifications

Edexcel is one of the leading examining and awarding bodies in the UK and throughout the world. We provide a wide range of qualifications including academic, vocational, occupational and specific programmes for employers.

Through a network of UK and overseas offices, Edexcel's centres receive the support they need to help them deliver their education and training programmes to learners.

For further information please call our Customer Response Centre on 0870 240 9800, or visit our website at www.edexcel.org.uk

Autumn 2000

Publications Code **UG 009334**

All the material in this publication is copyright

© Autumn 2000 Edexcel

Edexcel Foundation is a registered charity and a company limited by guarantee.

Registered in England No. 1686164

Contents

Specimen Paper 2F	p 1
Specimen Paper 2H	p 15
Specimen Mark Scheme 2F	p 27
Specimen Mark Scheme 2H	p 29
Specification Grid Papers 2F & 2H	p 31

Answer ALL questions in the spaces provided.







*Leave
blank*

1. The table below shows either some tools or components or equipment.

(a) Complete the table by:

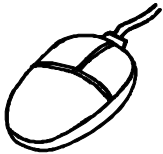
- (i) naming each tool or component or equipment;
- (ii) describing its use.

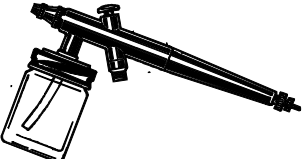
The first is done for you.

TOOL / COMPONENT / EQUIPMENT	NAME	DESCRIPTION
	Hot melt glue gun	Tool for gluing rigid materials
		
		
		
		
		

(10)

(b) Give **three** safety procedures which must be followed when using the hot melt glue gun.

1

2

3

(3)

(c) Name the most suitable adhesive for the following uses.

Use	Suitable Adhesive
Gluing paper on to paper	
Gluing a photograph on to card (allowing for repositioning)	
Gluing corrugated card on to foam board	

(3)

(d) The tabs on a cereal packet are either tacked (spot glued) or securely fixed using a suitable adhesive.

(i) On the net below, clearly label the tabs that will be tacked and those that will be securely fixed.

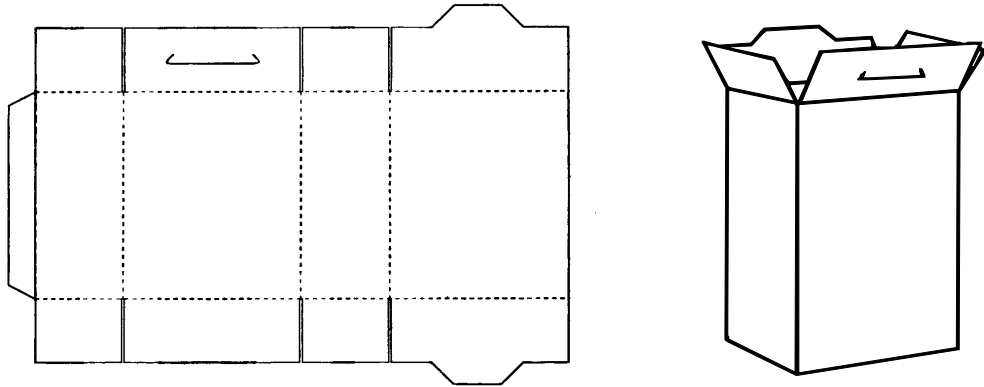

(3)

(ii) Give reasons for your answers to (d) (i).

.....

.....

.....

.....

.....

.....

(3)

Total 22 marks

BLANK PAGE

TURN OVER FOR QUESTION 2

2. A colour leaflet promoting the Valley Leisure Centre is to be distributed in the local area.

(a) The leaflet is to have a gloss surface finish to the paper.

(i) Name **two** printing effects that could be used to give a gloss finish

1

2

(2)

(ii) Explain **two** reasons why a gloss finish to the paper may be needed.

1

.....

2

.....

(4)

(b) 20,000 copies of the leaflet are to be printed. Name a suitable printing process and describe **two** advantages of using this process.

Name.....

Advantage 1

.....

Advantage 2.....

.....

(5)

(c) The Valley Leisure Centre serves the local community.

(i) Name **one** way in which the leaflet could be developed for:

1. The visually impaired.

.....

.....

2. The non-English speaking community.

.....

.....

(2)

*Leave
blank*

(ii) Name **two** pieces of information the leaflet would have to include for its physically disabled users.

1

2

(2)

(d) (i) The leaflet is just one part of an advertising campaign.

Name **three** other methods of advertising that the Valley Leisure Centre may want to consider.

1

2

3

(3)

(ii) Choose **two** of the methods you have named in (d) (i) and explain why each method would be successful.

Method 1

Explanation

.....

Method 2

Explanation

.....

(4)

Total 22 marks

3. A company is designing a bottle for a new unisex fragrance called 'Duo'.

The specification of the bottle is that it must:

- have an eye-catching shape;
 - incorporate the brand name 'Duo';
 - be made from durable material;
 - be mass produced.
- (a) In the spaces below, use notes and sketches to show **two** design ideas for the bottle which meet this specification.

DESIGN IDEA 1

DESIGN IDEA 2

*Leave
blank*

(8)

(b) Three of the specification points are given again below.

Use these headings to evaluate **one** of your design ideas against the initial specification.

1. Have an eye-catching shape.

.....
.....
.....
.....

2. Incorporate the brand name 'Duo'.

.....
.....
.....
.....

3. Be made from durable material.

.....
.....
.....
.....

(6)

(Total 22 marks)

4. The diagram below shows the prototype of a shop counter display for a new chocolate bar.

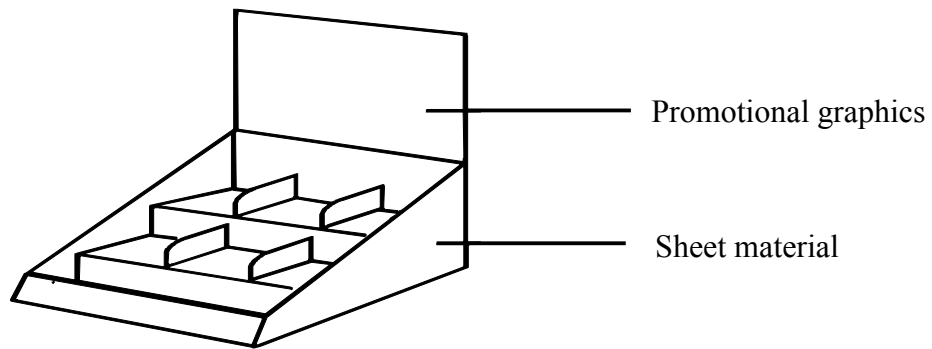

(a) Two specification points for the shop counter display are:

- the display must contain 20 chocolate bars;
- the display must appeal to young children.

Give **three** more points of specification which could be included in the specification of this display. For each point, give a reason why it should be included.

1

Reason

2

Reason

3

Reason

(6)

(b) Name **three** suitable specific materials for making this shop counter display.

1

2

3

(3)

- (c) Give **one** property associated with **one** of the materials you have named in (b) and explain how this property makes it suitable for this application.

Property

Explanation.....

.....
.....

(4)

- (d) This counter display is a one-off prototype using manual cut and paste techniques. Complete the diagram below to show the main stages in the one-off prototype production process of the net.

The first is done for you.

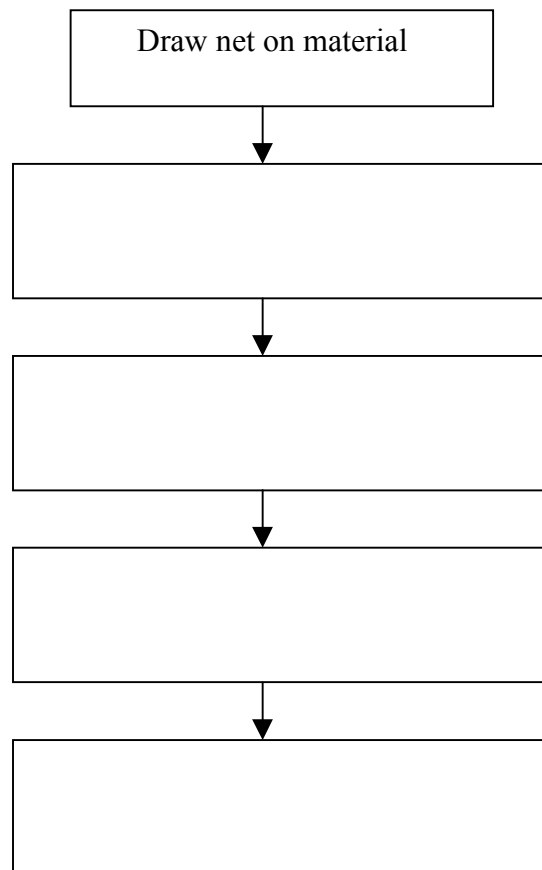

(5)

(e) The purpose of this display is to sell chocolate bars.

Describe how the display helps to achieve this purpose.

.....

.....

.....

.....

(4)

(Total 22 marks)

PAPER TOTAL 88 MARKS

END

*Leave
blank*

BLANK PAGE

Centre Number					Paper Reference	Surname
Candidate Number					Candidate Signature	Other Names

1972/2H

Edexcel GCSE

**Design and Technology:
Graphic Products
(Full Course)**

Paper 2H

HIGHER TIER

Specimen Papers

Time 1 ½ hours

N0000

Materials required for the examination

None

Items included with these question papers

None

For Examiner's use only

--	--	--

For Team Leader's use

--	--	--

Question Number	Leave Blank
1	
2	
3	
4	
Total	

Instructions to Candidates

In the boxes above, write your centre number, candidate number, the paper reference, your signature, your surname and other names. The paper reference is shown in the top left hand corner. Attempt ALL questions using the spaces provided in the Question Paper.

Information for Candidates

You may use drawing equipment and coloured pencils.
All measurements are in mm unless otherwise stated.

Advice to Candidates

You are reminded of the importance of clear and orderly presentation in your answers. Include diagrams where these are helpful.

N0000
© 2000 Edexcel
This publication may only be reproduced in accordance with Edexcel copyright policy.
Edexcel Foundation is a registered charity.



Answer ALL questions in the spaces provided.

Leave blank

1. The diagram below shows the prototype of a shop counter display for a new chocolate bar.

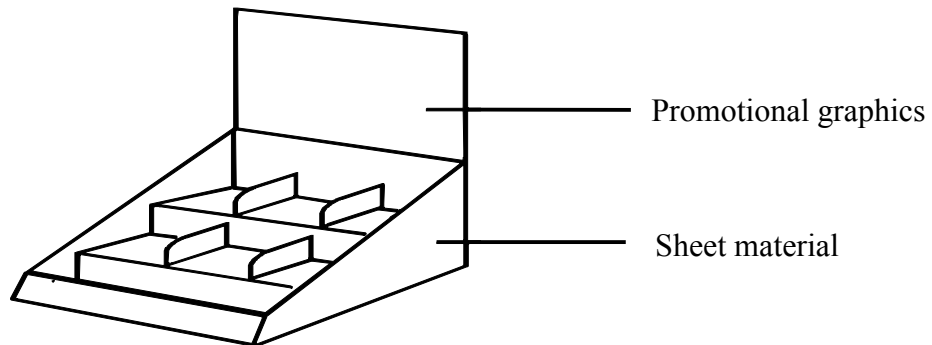

(a) Two specification points for the shop counter display are:

- the display must contain 20 chocolate bars;
- the display must appeal to young children.

Give **three** more points of specification which could be included in the specification of this display. For each point, give a reason why it should be included.

1

Reason

2

Reason

3

Reason

(6)

(b) Name **three** suitable specific materials for making this shop counter display.

1

2

3

(3)

- (c) Give **one** property associated with **one** of the materials you have named in (b) and explain how this property makes it suitable for this application.

Property

Explanation.....

.....
.....

(4)

- (d) This counter display is a one-off prototype using manual cut and paste techniques. Complete the diagram below to show the main stages in the one-off prototype production process of the net.

The first is done for you.

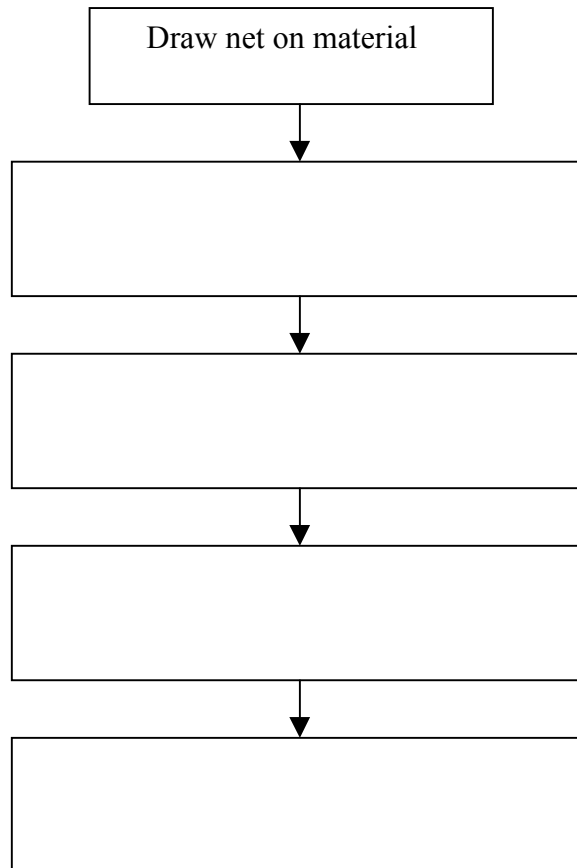

(5)

(e) The purpose of this display is to sell chocolate bars.

*Leave
blank*

Describe how the display helps to achieve this purpose.

.....

.....

.....

.....

.....

.....

(4)

(Total 22 marks)

*Leave
blank*

2. A printed brochure advertising a local company is to be produced. It must have a high quality appearance.

(a) (i) Name **two** printing effects which may give this appearance and describe how each is achieved.

Effect 1

Description

.....

Effect 2

Description

.....

(6)

(ii) Describe how the use of efficient lay planning would benefit the producer of this brochure.

.....

.....

(2)

(b) The diagram below shows the lithographic printing process.

Leave blank

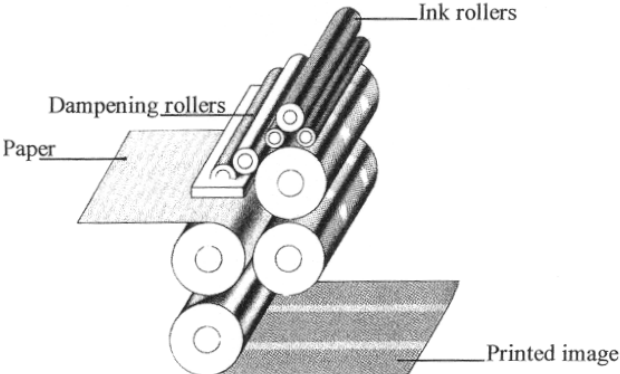

Explain **three** reasons why lithography is often used in preference to the letterpress printing process.

- 1
- 2
- 3

(6)

(c) The prototype brochure is to be produced using a computer the same as those found in most schools.

Leave blank

(i) Name **two** different uses for a computer when designing a Graphic Product.

- 1
- 2

(2)

(ii) Describe **three** qualities a computer has that make it suitable for small scale production.

- 1
-
- 2
-
- 3
-

(6)

(Total 22 marks)

3. Corrugated card and expanded polystyrene are often used to package electrical products.

(a) For corrugated card give **three** characteristics that make it suitable for packaging electrical products.

- 1
- 2
- 3

(3)

(b) For expanded polystyrene give **two** different characteristics that make it suitable for packaging electrical products.

- 1
- 2

(2)

(c) Solid board is another material used for packaging electrical products.

Explain **two** advantages and **one** disadvantage of its use over corrugated card.

Advantage 1

.....

Advantage 2

.....

Disadvantage

.....

(6)

(d) Disposal of packaging materials after use may have environmental implications.

(i) Give **three** effects disposal of packaging material may have on the environment.

- 1
- 2
- 3

(3)

(ii) Describe **three** ways in which damage to the environment could be limited when disposing of packaging materials.

1

.....

2

.....

3

.....

(6)

(iii) Explain how PVC may have damaging effects on health and the environment.

.....

.....

(2)

(Total 22 marks)

*Leave
blank*

4. A company is designing the casing of a mobile phone.

The specification for the casing is that it must:

- be attractive in colour and shape;
- be pocket sized;
- be made from a durable material;
- be mass-produced.

- (a) In the spaces below, use notes and sketches to show **two** design ideas for the casing which meet this specification.

DESIGN IDEA 1

DESIGN IDEA 2

*Leave
blank*

(8)

DESIGN & TECHNOLOGY: GRAPHIC PRODUCTS (1972/2F)
FULL COURSE FOUNDATION TIER MARK SCHEME

Qu.	Prt Qu.	Sub Qu.	Detailed Possible Answers	Mark Alloc.	Sub. Total
1	(a)	(i)	Name: Fine line pen, Name: computer mouse, Name: scalpel, Name: Airbrush Name: French Curve	5x1	
		(ii)	Use: Sketching and drawing, Use: controlling cursor on screen, Use: cutting sheet materials Use: Painting Use: Drawing curves	5x1	(10)
	(b)		Use a gluing surface/protect desk top, bench etc Keep fingers away from hot surfaces Avoid deliberate misuse causing burns Leave on stand not on side Electrical safety	3x1	(3)
	(c)		Glue stick/spray mount Spray mount Hot melt glue	3x1	(3)
	(d)	(i)	Labelling; top – tacked; bottom – secure and side seam – secure	3x1	(3)
		(ii)	Top of box tacked for transporting but can easily be opened when purchased – tab lock secures top Bottom and seams of box are secured to give strength and rigidity to structure – containing product without spillage	3x1	(3)
					(22)
2	(a)	(i)	Laminating; varnishing	2x1	(2)
		(ii)	Explanation which makes reference to: High quality finish – visual impact Strengthen paper structure Durability	2x2	(4)
	(b)		Lithography Widely used modern printing process, many suppliers, good print quality, most economical process for general printing Ideal for medium to long runs	1 2x2	(5)
	(c)	(i)	1. Larger type 2. Reprint in appropriate language, visual symbols instead of text where appropriate	1 1	(2)
		(ii)	Appropriate facilities – disabled access/toilets/car parking Specific disabled activities	2x1	(2)

Qu.	Prt Qu.	Sub Qu.	Detailed Possible Answers	Mark Alloc.	Sub. Total
	(d)	(i)	Local TV and radio advertisements targeting the local community, local newspaper adverts, billboards, public transport – buses, taxis, tubes, trains, town centre, Promotions – keep fit displays, fancy dress mascots etc. – Leaflet handouts, mail-shot leaflet distribution	3x1	(3)
		(ii)	Successful advertising method would attract attention, provide information about the leisure centre to the local community, put the message across in a memorable way etc.	2x2	(4)
					(22)
3	(a)		DESIGN IDEA 1 Each spec point resolved in design (fully = 2, partly = 1)	4x2	(8)
			DESIGN IDEA 2 Each spec point resolved in design (fully = 2, partly = 1)	4x2	(8)
	(b)		Each point clearly evaluated (fully = 2, partly = 1)	3x2	(6)
					(22)
4	(a)		Accept any three relevant points of specification and reasons eg: Point: The display must incorporate company name / logo Reason: To promote company Point: The display must incorporate product name / logo Reason: To promote product Point: Must be lightweight Reason: To ensure it is mobile Point: Must be robust / hardwearing Reason: To ensure it does not need replacing frequently	6x1	(6)
	(b)		Foam-board	1	
			Corrugated card, corrugated plastic sheet	1	
			Solid board	1	(3)
	(c)		Strength / rigidity / low cost / easily cut and shaped / good printing surface Explanation	1+3	(4)
	(d)		Add graphics whilst flat / cut out / score and fold / glue Correct sequence	4x1 1	(5)
	(e)		Customers when paying for goods at counter are attracted by display and purchase product. High visual impact attracts customer	2x2	(4)
					(22)
			TOTAL FOR PAPER 88 MARKS		

**DESIGN & TECHNOLOGY: GRAPHIC PRODUCTS (1972/2H)
FULL COURSE HIGHER TIER MARK SCHEME**

Qu.	Prt Qu.	Sub Qu.	Detailed Possible Answers	Mark Alloc.	Sub. Total		
1	(a)		Accept any three relevant points of specification and reasons eg: Point: The display must incorporate company name / logo Reason: To promote company Point: The display must incorporate product name / logo Reason: To promote product Point: Must be lightweight Reason: To ensure it is mobile Point: Must be robust / hardwearing Reason: To ensure it does not need replacing frequently	6x1	(6)		
			(b)	Foam board	1		
				Corrugated card, corrugated plastic sheet	1		
				Solid board	1	(3)	
			(c)	Strength / rigidity / low cost / easily cut and shaped / good printing surface Explanation	1+3	(4)	
			(d)	Add graphics whilst flat / cut out / score and fold / glue Correct sequence	4x1 1	(5)	
			(e)	Customers when paying for goods at counter are attracted by display and purchase product. High visual impact attracts customer.	2x2	(4)	
						(22)	
		2	(a)	(i)	Naming printing effect Description Laminating – gives paper a high gloss look / strengthens / protects; varnishing – selected areas of text or images varnished for highlighting and high visual impact/protection die cutting special shapes cut out of paper – high visual impact; embossing – portion of surface raised – high visual impact	2x1 2x2	(6)
				(ii)	Optimises use of sheet material; cut to accurate size; therefore saving materials and reduction in wastage and cost	2x1	(2)
(b)			Explanation making reference to 3 Reasons for Lithography – widely used printing process; many suppliers; good print quality; economical; ideal for medium to long runs	3x2	(6)		

Qu.	Prt Qu.	Sub Qu.	Detailed Possible Answers	Mark Alloc.	Sub. Total
	(c)	(i)	Desk top publishing, draw and paint, spell checks, various fonts, professional quality documents etc	2x1	(2)
		(ii)	Description of qualities making reference to: Good print quality from output devices such as printer / plotter Identical reproduction of images and data Cheap to run/print, labour saving	3x2	(6)
					(22)
3	(a)		Corrugated card – low cost protective packaging for boxes / recyclable; rigid and strong; can be printed on	3x1	(3)
	(b)		Polystyrene block – low cost packaging used in conjunction with cardboard box / impact absorbing; light	2x1	(2)
	(c)		Advantages – excellent printing surface for advertising / very strong for protection Disadvantages – higher cost than corrugated card; environmental effect of bleaching board during manufacture	3x2	(6)
	(d)	(i)	Any 3 effects from: Landfill, toxic gasses, toxins deposited, non-biodegradable, production of carbon dioxide	3x1	(3)
		(ii)	Reduction in use of packaging materials – reduce thickness of cardboard without losing strength, less polystyrene packaging Recycling – cardboard pulped and re-processed and greater use of recycled cardboard boxes Biodegradability – polystyrene substituted with recycled card structure for packaging	3x2	(6)
		(iii)	Explanation which makes reference to: Chloride used in manufacture Potential to produce hydrochloric acid and dioxins	2x1	(2)
					(22)
4	(a)		DESIGN IDEA 1 Each spec point resolved in design (fully = 2, partly = 1)	4x2	(8)
			DESIGN IDEA 2 Each spec point resolved in design (fully = 2, partly = 1)	4x2	(8)
	(b)		Each point clearly evaluated (fully = 2, partly = 1)		(6)
					(22)
			TOTAL FOR PAPER 88 MARKS		

**DESIGN & TECHNOLOGY: GRAPHIC PRODUCTS (1972)
SPECIFICATION GRID**

PAPER 2F				
Quest	Assessment objective tested	Content covered by question	Question style/type	Marks
1	AO1	Preparing, processing and finishing materials and manufacturing commercial products	Structured question on a theme.	Total 22
2	AO1 + AO3	Classification and selection of materials and components. Design and market influence, parts (i) and (ii) not covered in question 3.	Structured question on a theme.	11 + 11 Total 22
3	AO2	Design question. This question accounts for all 10% of designing marks.	Design question – candidates design a product from a specification and evaluate against the specification.	Total 22
4	AO3	Design and market influence, part (iii).	Product analysis – candidates are asked to analyse a product following the analysis process.	Total 22
PAPER 2H				
Quest	Assessment objective tested	Content covered by question	Question style/type	Marks
1	AO3	Design and market influence, part (iii).	Product analysis – candidates are asked to analyse a product following the analysis process.	Total 22
2	AO1	Preparing, processing and finishing materials and manufacturing commercial products	Structured question on a theme.	Total 22
3	AO1 + AO3	Classification and selection of materials and components. Design and market influence, parts (i) and (ii) not covered in question 3.	Structured question on a theme.	11 + 11 Total 22
4	AO2	Design question. This question accounts for all 10% of designing marks.	Design question – candidates design a product from a specification and evaluate against the specification.	Total 22

Further copies of this publication are available from
Edexcel Publications, Adamsway, Mansfield, Notts, NG18 4FN

Telephone 01623 467467
Fax 01623 450481

Order Code **UG 009334**
Summer 2000

For more information on Edexcel qualifications please contact our
Customer Response Centre on 0870 240 9800
or email: enquiries@edexcel.org.uk
or visit our website: www.edexcel.org.uk

Edexcel Foundation is a registered charity and a company limited
by guarantee. Registered in England No. 1686164

Edexcel
Success through qualifications

