





Answer ALL the questions. Write your answers in the spaces provided.

1. The table below shows some tools and equipment.

(a) Complete the table by:

- (i) naming each tool or item of equipment
- (ii) describing its use.

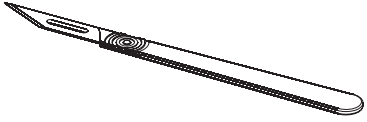
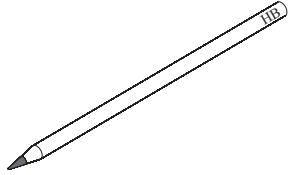
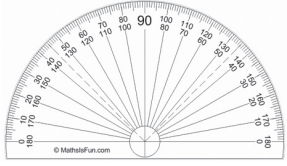
The first one has been done for you.

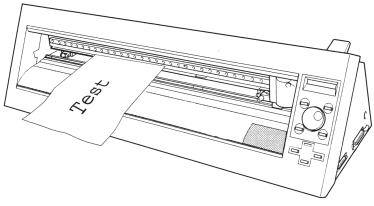
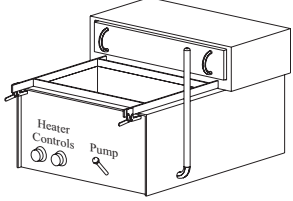
Tool / Equipment	Name	Use
	Scalpel	Cutting card
		
		
		
		
		

(10)



(b) Shown below are two items of equipment used when cutting card with a scalpel.

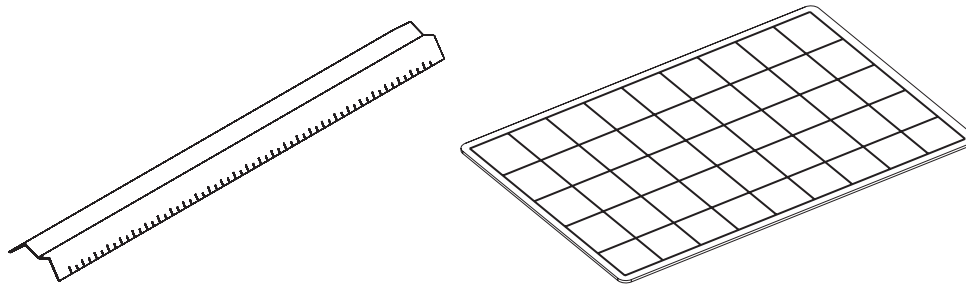

Name the **two** pieces of equipment shown above.

1 .....

2 .....

(2)

(c) Materials that have been cut can be joined together with glue.

Name a glue that is suitable to join each of the materials listed below.

Each named glue should be different.

The first one has been done for you.

Material	Glue
Paper	Glue stick
Pine	
Acrylic	
Aluminium	

(3)



(d) The drawing below shows a business card for a club.

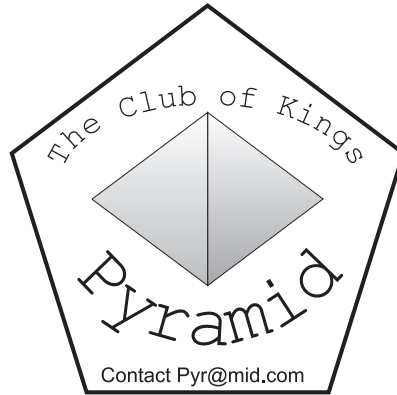

(i) The business cards are produced 1000 copies at a time.

Name this scale of production.

.....  
(1)

(ii) The manufacturer of the business card prints several copies of the card onto a single sheet. The shapes are arranged to minimise the waste.

Name the process of arranging shapes to minimise waste.

.....  
(1)

(iii) During the manufacture of the business card, the quality of printing would be tested.

Name **two** methods of testing the quality of printing.

1 .....

.....

2 .....

.....  
(2)



(e) Email is used for communication.

State **three disadvantages** of using email for communication.

1 .....

.....

2 .....

.....

3 .....

.....

(3)

(Total 22 marks)

Leave  
blank

Q1

--	--



2. The drawing below shows a model of a shop produced by a student.

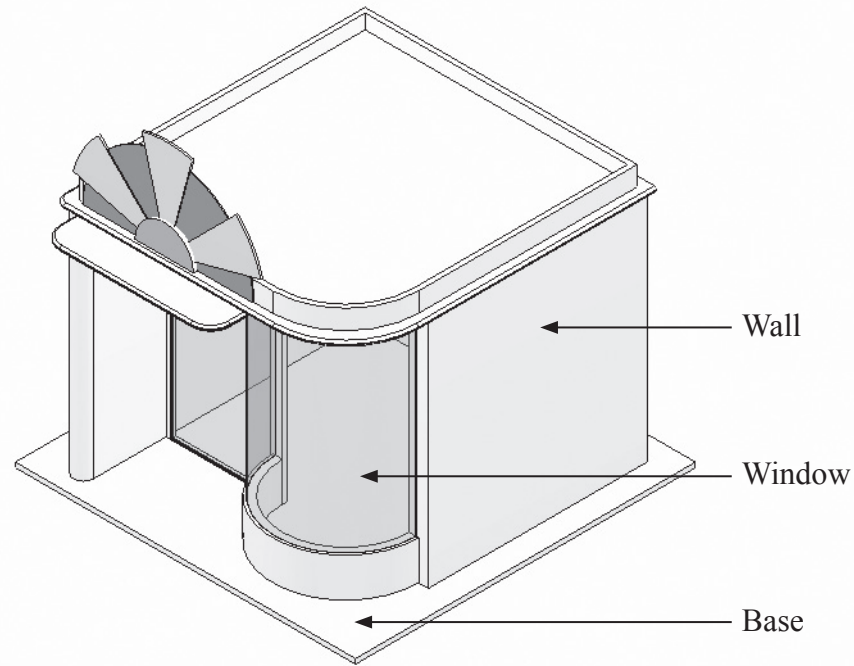

(a) The model is made from materials with differing properties.

On the table below draw a line to link the name of a property to the meaning of that property. The first one has been done for you.

Name of property	Meaning of property
Texture	How hard it is to break a material
Strength	The way a material looks
Rigidity	How hard it is to bend a material
Visual impact	How a material feels to touch

(3)



Leave  
blank

(b) The walls are made from corrugated card.

In the space below, draw the edge of a piece of corrugated card.

(2)

(c) The walls had colour put onto them using an airbrush.

State **two** advantages of applying colour with an airbrush compared with using colouring pencils.

1 .....

.....

2 .....

.....

(2)

(d) The window is made from acetate.

State **two** properties of acetate that make it a suitable material for the window.

1 .....

.....

2 .....

.....

(2)



(e) CAD software programmes have a number of tools.

Complete the table below by stating what each tool does.

The first one has been done for you.

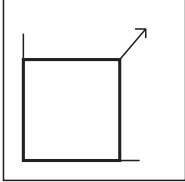
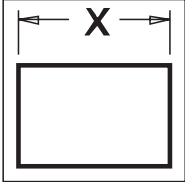
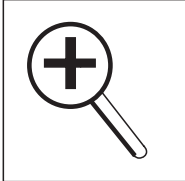
Tool	What the tool does
	Draws a rectangle
	
	

(2)

(f) CAD/CAM is often used commercially to reduce the cost of producing graphic products.

State **two** ways in which the use of CAD/CAM can reduce production costs.

1 .....

.....

2 .....

.....

(2)





Leave  
blank

(g) The model uses fibre optics to light the inside, making it look more realistic and attractive.

(i) Give **two** practical advantages of using fibre optics to light up the inside of the model.

1 .....

.....

2 .....

.....

(2)

(ii) The fibre optics are tested to meet standards set by the British Standards Institute (BSI).

State **two** advantages of products being tested by the BSI.

1 .....

.....

2 .....

.....

(2)

(h) The model is designed to be used for a short period of time and then thrown away.

This is an example of planned product obsolescence.

State **two** environmental problems linked to planned product obsolescence.

1 .....

.....

2 .....

.....

(2)





<p>(i) The internet was used to collect information about the materials used in the model.</p> <p>State <b>three advantages</b> of using the internet to gather information.</p> <p>1 .....</p> <p>.....</p> <p>2 .....</p> <p>.....</p> <p>3 .....</p> <p>.....</p> <p style="text-align: right;">(3)</p> <p style="text-align: right;"><b>(Total 22 marks)</b></p>	Leave blank
	Q2



**BLANK PAGE**



3. The drawing below shows a pen and pencil gift set.

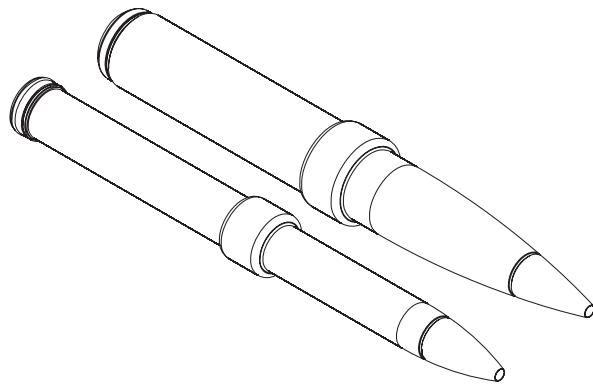

A package is required to hold the pen and pencil.

The specification for the package is that it must:

- allow the pen and pencil to be seen inside a sealed package
- hold the pen and pencil separately
- have space to display the words 'Pen and Pencil' and 'Gift Set'
- be made using materials and processes suitable for one-off production.

(a) In the spaces opposite, use sketches and, where necessary, brief notes to show **two different** design ideas for the **package** which meet this specification.

Do **not** evaluate your designs in part (a).

Candidates are reminded that if pencil is used for diagrams/sketches that it must be dark (HB or B). Coloured pens, pencils and highlighter pens must **not** be used.

**PLEASE DO NOT WRITE OR DRAW IN THIS SPACE.**

**PLEASE USE THE SPACES OPPOSITE FOR YOUR DESIGNS.**



**Design Idea 1**

Leave  
blank

**(8)**

**Design Idea 2**

**(8)**



Leave  
blank

(b) Three of the original specification points are repeated below.

Evaluate how **one** of your design ideas succeeds or fails to meet each of these specification points.

Write the number of your chosen design idea (1 or 2) here: .....

(i) Allow the pen and pencil to be seen inside a sealed package.

.....  
.....  
.....  
.....

(2)

(ii) Hold the pen and pencil separately.

.....  
.....  
.....  
.....

(2)

(iii) Be made using materials and processes suitable for one-off production.

.....  
.....  
.....  
.....

(2)

(Total 22 marks)

Q3



**BLANK PAGE**



4. The drawing below shows a child's letterpress stamping set.  
The lid fits tightly onto the bottom.

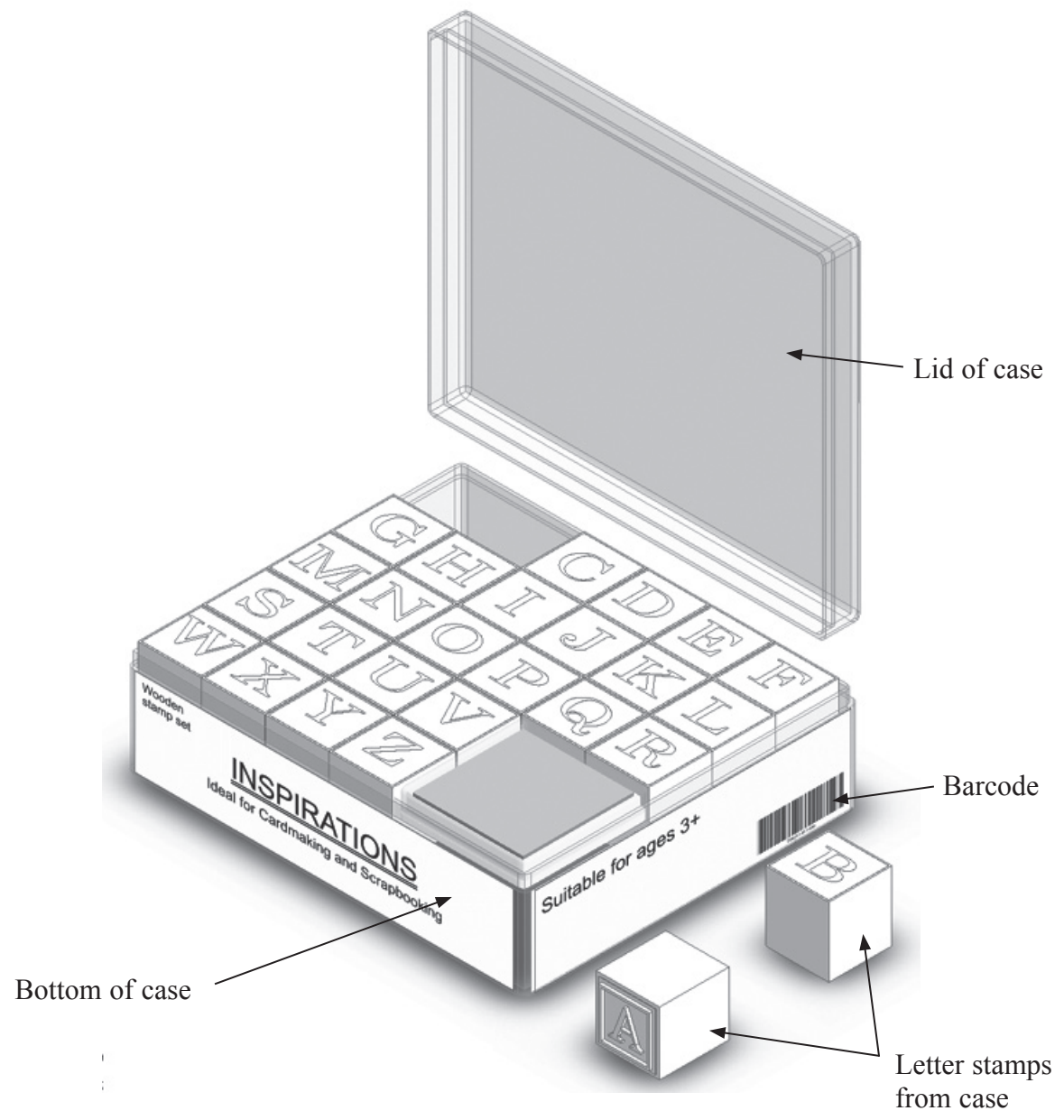



(a) Two specification points for the **case** of the stamping set are that it must:

- protect the contents
- allow the retailer to easily monitor sales.

Under each of the following headings, give **one** more point that should be included in the specification for the case.

For each point, give **one** reason why it should be included.

(i) **Quality**

Point .....

.....

Reason .....

.....

.....

(2)

(ii) **Environment**

Point .....

.....

Reason .....

.....

.....

(2)

(iii) **Safety**

Point .....

.....

Reason .....

.....

.....

(2)



(b) The drawing below shows one of the letter stamps.

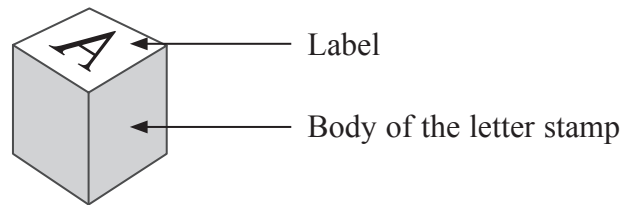

The body of the letter stamp is made from pine.

One reason why the body of the letter stamp is made from pine is that it is attractive.

Give **two** other reasons why pine is a suitable material from which to make the body of the letter stamp.

1 .....

.....

2 .....

.....

(2)

(c) The label on the top of the letter stamp is manufactured using lithography.

Give **two** reasons why lithography is a suitable process to manufacture the label.

1 .....

.....

2 .....

.....

(2)

(d) The label on the top of the letter stamp is finished by using varnishing.

Explain **one** reason why varnishing is used for finishing this label.

.....

.....

(2)



(e) The drawing below shows the case of the stamping set.

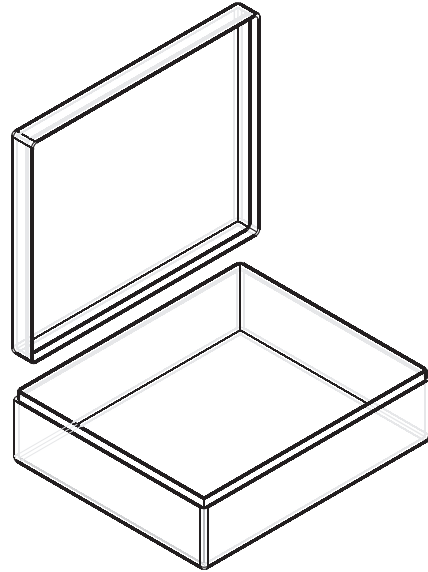

The case is made from acrylic.

Give **two** properties of acrylic that make it a suitable material for the case.

For each property, give **one** reason why it makes acrylic suitable.

Property 1 .....

Reason .....

.....

Property 2 .....

Reason .....

.....

**(4)**



Leave  
blank

(f) The manufacturer of the case uses sampling during production.

Explain **one** reason for sampling during the production of the case.

.....  
.....  
.....  
.....

(2)

(g) Two purposes of the **case** of the stamping set are to:

- protect the contents
- allow the retailer to easily monitor sales.

Explain under the following headings how the **case** of the stamping set achieves these purposes.

(i) Protect the contents.

.....  
.....  
.....  
.....

(2)

(ii) Allow the retailer to easily monitor sales.

.....  
.....  
.....  
.....

(2)

Q4

(Total 22 marks)

**TOTAL FOR PAPER: 88 MARKS**

**END**

