

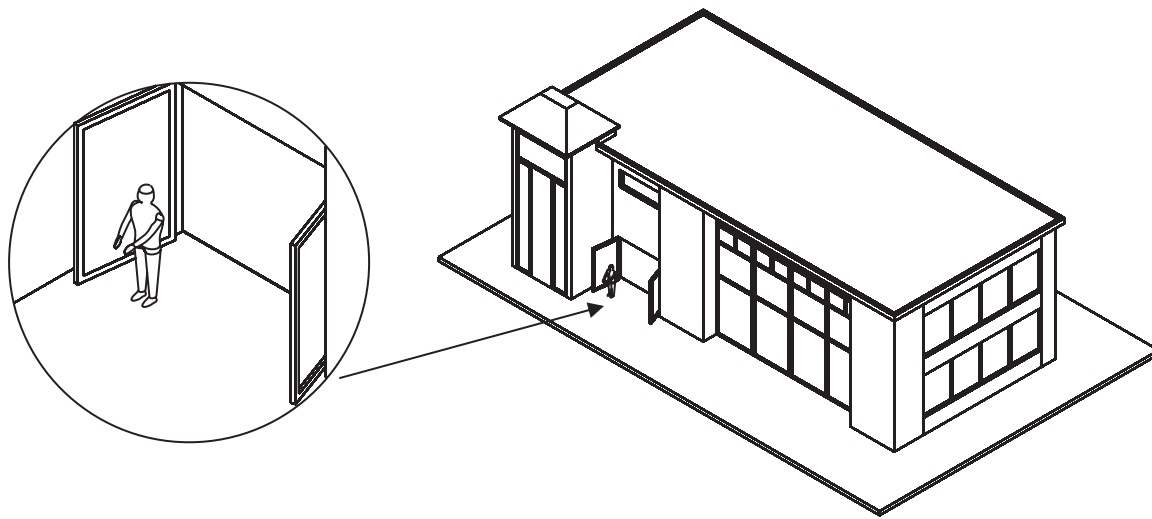

Answer ALL the questions. Write your answers in the spaces provided.

1. The drawing below shows an architect's model of a new library that was made for a local council. The model is designed to be displayed to show users of the new building what it will look like.



Enlarged view showing a scale model of a person

Architect's model of library

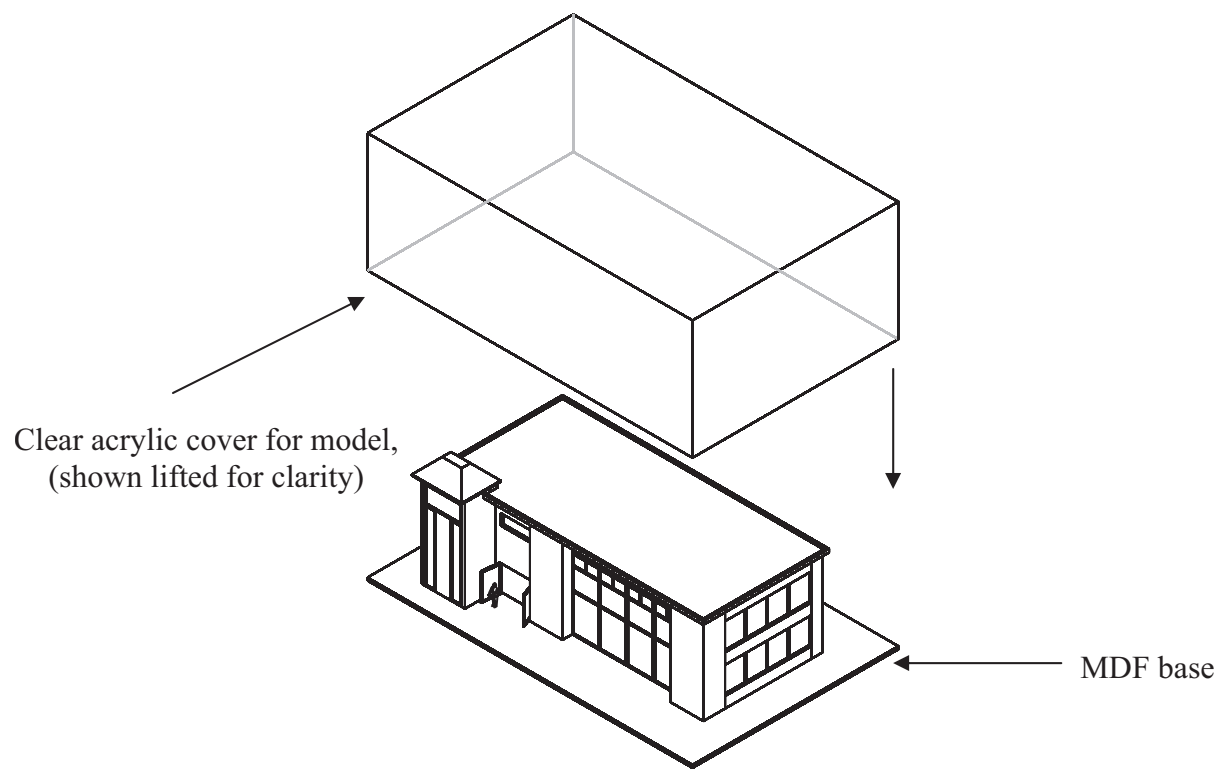

Additional data:  
The model is 1000 mm long, 500 mm wide and 300 mm tall.  
Battery powered lights are used to illuminate the interior.



Leave  
blank

(a) Two specification points for the architect's model are that it must:

- show viewers the scale of the building
- be durable.

Under each of the following headings, give **one** more point that should be included in the specification for the architect's model.

For each point, give **one** reason why it should be included.

(i) The needs of the user.

Point .....

Reason .....

.....

.....

(2)

(ii) Environmental considerations.

Point .....

Reason .....

.....

.....

(2)

(iii) Quality.

Point .....

Reason .....

.....

.....

(2)



(b) The base is made from MDF.

One reason for using MDF to make the base is that it is cost effective.

Give **two** other reasons why MDF is a suitable material from which to make the base.

1 .....

2 .....

(2)

(c) The drawing below shows printed paper that is stuck to the walls to make them look realistic.

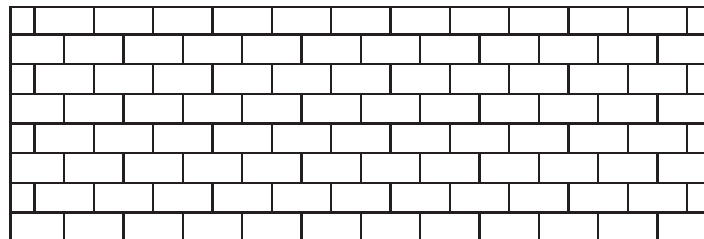

The printed paper is manufactured by lithography.

Give **two** reasons why lithography is a suitable process to manufacture the printed paper.

1 .....

2 .....

(2)



Leave  
blank

(d) The drawing below shows a wall from the architect's model.

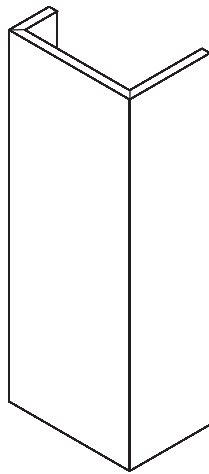

The wall is made from foamboard.

Give **two** properties of foamboard that make it a suitable material from which to make the wall.

For **each** property give **one** reason why it makes foamboard suitable for the wall.

Property 1 .....

Reason .....

.....

.....

Property 2 .....

Reason .....

.....

.....

(4)



- (e) Quality control checks are carried out at important stages during the manufacture of the acrylic cover.

The cover is manufactured by gluing together five pieces of acrylic.

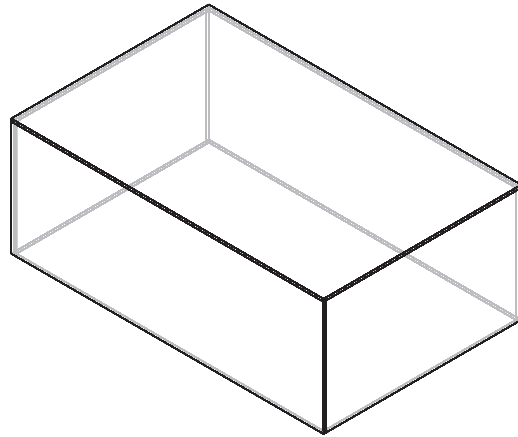

Clear acrylic cover

Name **two** important quality control checks, other than safety, that should be made during the manufacture of the clear acrylic cover.

1 .....

2 .....

(2)

- (f) The drawing below shows part of the roof of the architect's model. It is a bought-in component.

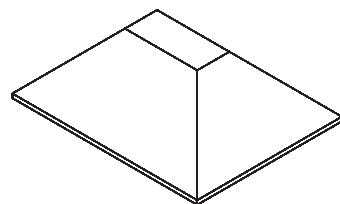

Top view of roof

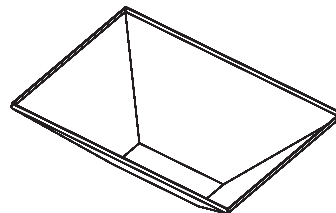

View of roof upside down

The roof is made in batches using vacuum forming.

The shape of the roof makes it suitable to be made using the vacuum forming process.

Describe **one** way in which the shape of the roof makes it suitable to be made in batches using the vacuum forming process.

.....

.....

(2)



Leave  
blank

(g) Two purposes of the architect's model are to:

- show viewers the scale of the building
- be durable.

Explain under the following headings, how the architect's model achieves these purposes.

(i) Show viewers the scale of the building.

.....  
.....  
.....  
.....

(2)

(ii) Be durable.

.....  
.....  
.....  
.....

(2)

(Total 22 marks)

Q1



2. The picture below shows the front cover of a book about art. The book is to contain full colour photographs and images.

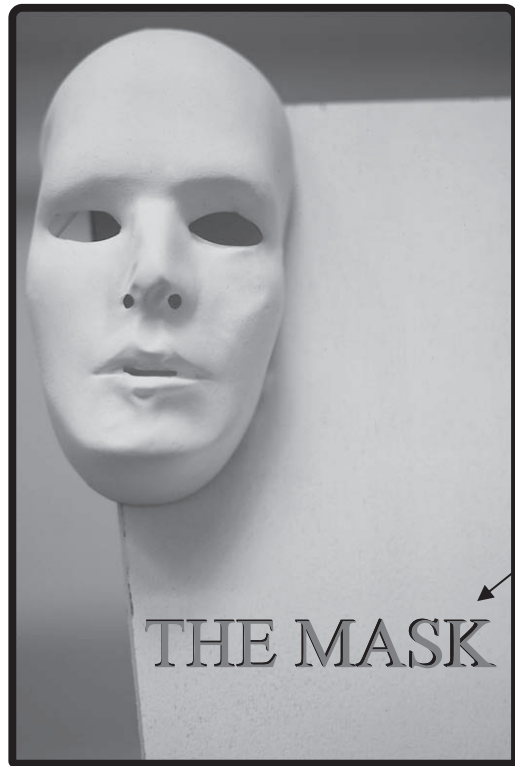

Lettering raised above surface

- (a) The lettering on the front of the book is to be raised above the surface.
- (i) Name **one** process that could be used to raise the lettering.
- .....
- (1)**
- (ii) In the space below, draw the parts of the tool that would be used to produce the raised letter 'T'.

**(2)**





(b) The images in the book could be printed using either the gravure or the lithographic process.

State **two** advantages of using the gravure process compared to the lithographic process.

1 .....

2 .....

(2)

(c) The drawing below shows one of the pages from the book.

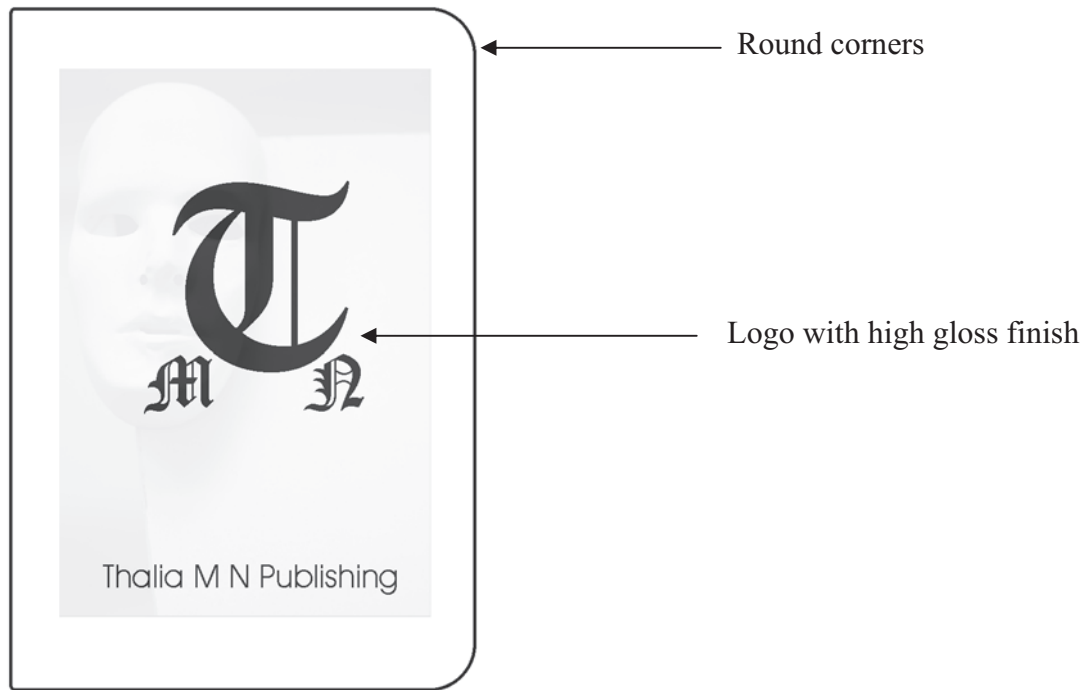

(i) The page is to have round corners.

Name **one** commercial cutting process that could be used to cut the page to shape.

.....

(1)

(ii) The logo on the page is to have a high gloss finish.

Name **one** commercial enhancement process that could be used to apply a high gloss finish to the logo.

.....

(1)



(d) A digital camera will be used to take photographs. These are to be used to produce the artwork for the book.

Explain **two** advantages of using a digital camera to take these photographs.

1 .....

.....

.....

2 .....

.....

.....

(4)

(e) (i) The drawing below shows a greyscale that is used to check the density of printing is consistent.



Name **one** device that could be used to optically measure the density of the printing.

.....

(1)

(ii) Registration marks are used to align the colour separations.  
In the space below draw a registration mark.

(1)



Leave blank

(f) The sale of the book will be monitored using EPOS tills.

Name **one** image to be printed on the back of the book to allow sales to be monitored using EPOS tills.

.....  
(1)

(g) During the design stages of the book the manufacturer used ICT for communication.

(i) E-mail was used to exchange information.

State **two** advantages of using e-mail for to exchange information.

1 .....

2 .....

(2)

(ii) The internet was used to gather information.

State **two disadvantages** of using the internet to gather information.

1 .....

2 .....

(2)

(h) The manufacturer uses lay planning when producing the books.

Give **two** advantages to the manufacturer of using lay planning when producing the books.

1 .....

2 .....

(2)

(i) The manufacturer uses Computer Integrated Manufacture (CIM) to produce the book.

Explain **one** advantage for the manufacturer of using CIM to produce the book.

.....

.....

.....

.....

(2)

(Total 22 marks)

Q2



3. A new film called “The House” is being shown in cinemas.  
A promotional display is required that can be placed inside cinemas.

The specification for the promotional display is that it must:

- be freestanding and have a place to hold A4 size advertisements that customers can take away
- be capable of being delivered as a flat pack and assembled without the use of tools
- display the film name “The House” and the slogan “A film for all the family”
- be suitable for batch production methods and materials.

Additional Data:

The A4 advertisements measure 297 mm x 210 mm.

- (a) In the spaces opposite, use sketches and, where necessary, brief notes to show **two different** design ideas for the promotional display that meet this specification.

Do **not** evaluate your designs in part (a).

Candidates are reminded that if pencil is used for diagrams/sketches, it must be dark (HB or B). Coloured pens, pencils and highlighter pens must **not** be used.

**PLEASE DO NOT WRITE OR DRAW IN THIS SPACE.**

**PLEASE USE THE SPACES OPPOSITE FOR YOUR DESIGNS.**



**Design Idea 1**

Leave  
blank

**(8)**

**Design Idea 2**

**(8)**



Leave blank

(b) Three of the original specification points are repeated below.

Evaluate how **one** of your design ideas succeeds or fails to meet each of these specification points.

Write down the number of your chosen design idea (1 or 2) here: .....

(i) The promotional display must be freestanding and have a place to hold A4 size advertisements that customers can take away.

.....  
.....  
.....

(2)

(ii) The promotional display must be capable of being delivered as a flat pack and assembled without the use of tools.

.....  
.....  
.....

(2)

(iii) The promotional display must display the film name "The House" and the slogan "A film for all the family".

.....  
.....  
.....

(2)

(Total 22 marks)

Q3



4. The drawing below shows a stand which holds spices packaged in jars.

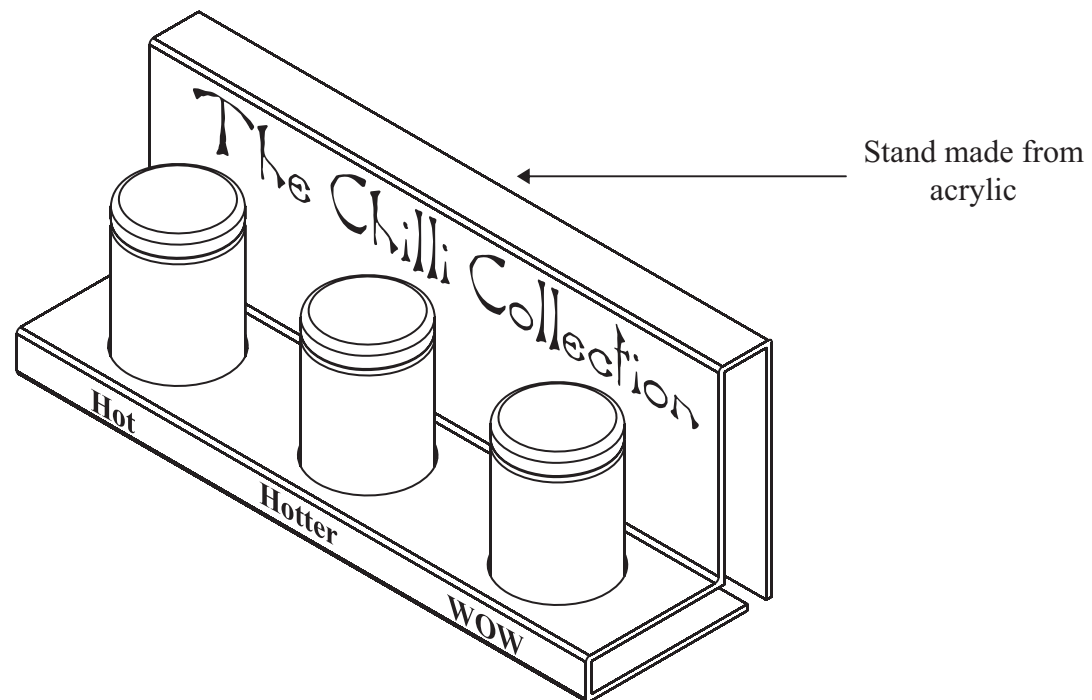

(a) The stand is made from acrylic. It is designed to be used in a kitchen.

One property of acrylic is that it has a smooth surface finish.

Explain **one** reason why having a smooth surface finish is important for objects used in a kitchen.

.....  
.....

(2)



(b) The drawing below shows one of the spice jars with the lid open.

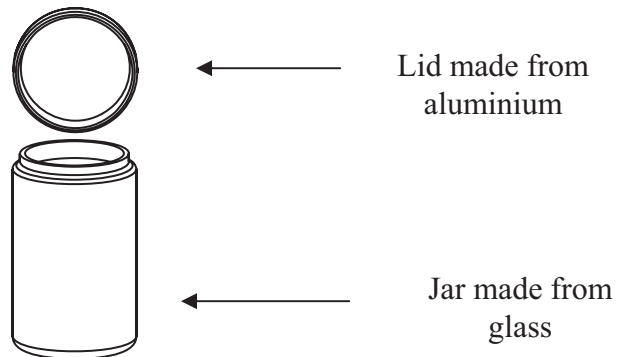

Glass and aluminium can both be recycled.

(i) State **three** other properties of glass that make it a suitable material from which to make the jars.

1 .....

2 .....

3 .....

(3)

(ii) State **three** properties of aluminium, different from those given for glass, that make it a suitable material from which to make the lids.

1 .....

2 .....

3 .....

(3)





(c) The drawing below shows another stand for the spice jars.

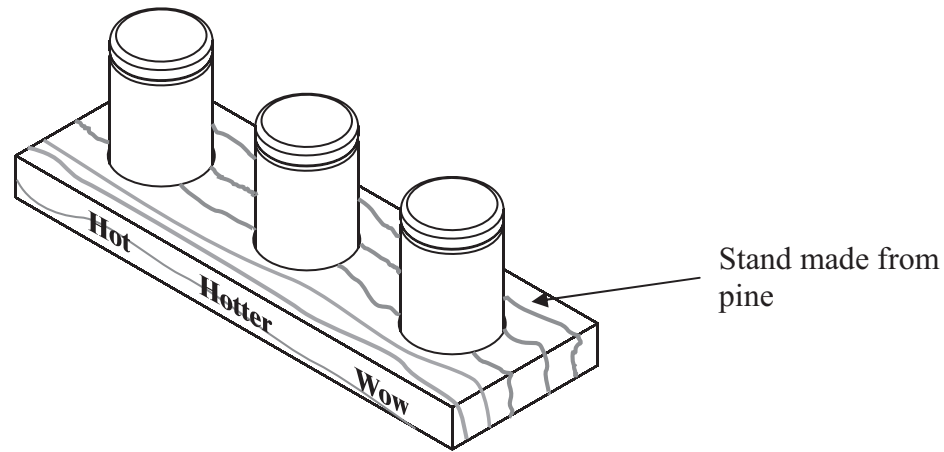

Pine was chosen as the material from which to manufacture the stand in preference to MDF.

State **three** advantages of using pine instead of MDF.

- 1 .....
- 2 .....
- 3 ..... **(3)**

(d) The spice jars are designed to be refilled once the contents are used.

State **two** environmental advantages of re-using the spice jars by re-filling them.

- 1 .....
- 2 ..... **(2)**



(e) Information displayed on packaging is controlled by regulations.

State **one** advantage, for the consumer, of including each of the following pieces of information on package labelling.

Each answer must be different.

(i) A list of ingredients.

..... (1)

(ii) The origin of the product.

..... (1)

(iii) The weight of the product.

..... (1)

(f) Some food products have labels that use a temperature sensitive coating.

Explain **one** advantage, for the consumer, of labels having a temperature sensitive coating.

.....  
..... (2)



Leave  
blank

(g) The use of CAD/CAM to manufacture graphic products has both advantages and disadvantages for society.

(i) Explain **one** advantage for society of using CAD/CAM.

.....  
.....

(2)

(ii) Explain **one disadvantage** for society of using CAD/CAM.

.....  
.....

(2)

Q4

(Total 22 marks)

**TOTAL FOR PAPER: 88 MARKS**

**END**



**BLANK PAGE**

