

Answer ALL the questions. Write your answers in the spaces provided.

1. The pictures below show a board game.

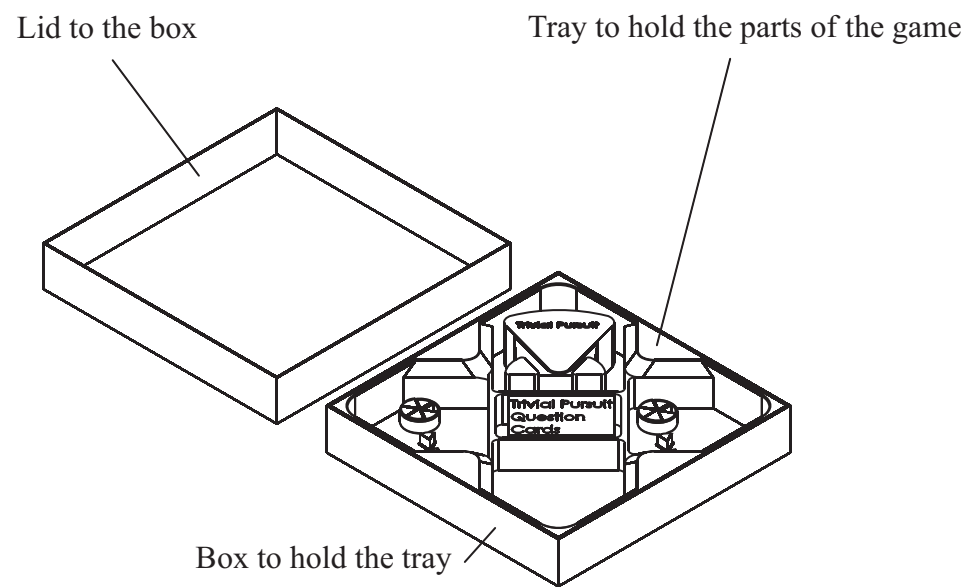
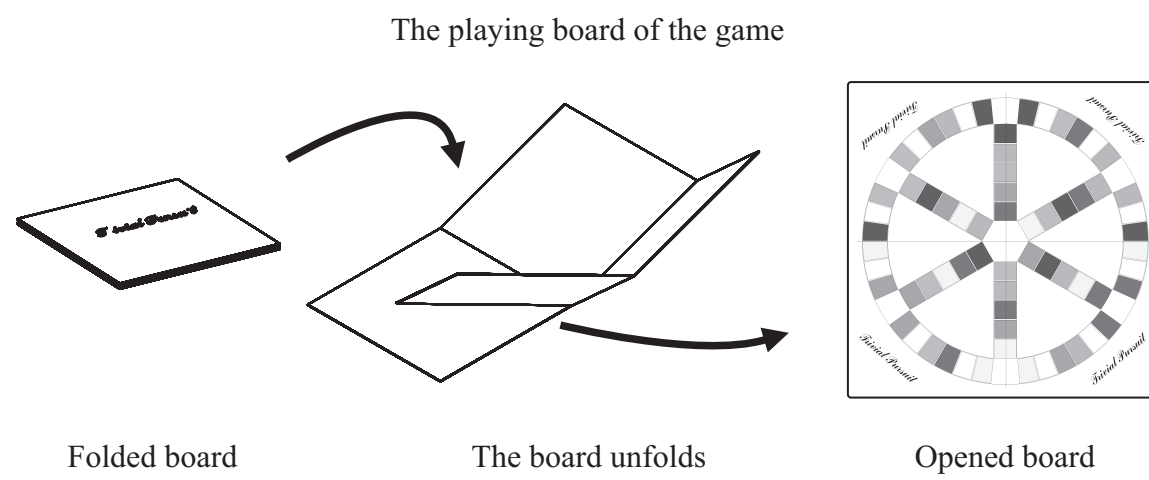

Leave
blank

(a) Two specification points for the board game are that it must be

- safe for users
- easy to store

Under each of the following headings, give **one** more point that should be included in the specification for the board game.

For each point, give **one** reason why it should be included.

(i) **Market**

Point

Reason

.....

.....

(2)

(ii) **Environment**

Point

Reason

.....

.....

(2)

(iii) **Quality**

Point

Reason

.....

.....

(2)



Leave
blank

(b) The picture below shows part of the printed playing board of the game.



© 2007 Hom Abbot International Limited. Trivial Pursuit™ is a registered trademark of Hom Abbot International Limited. Used with permission.

(i) The playing board is made from a card base and covered with a layer of printed paper.

One reason why the playing board is covered with paper is so it can be finished with varnish.

Give **two** other reasons why paper is a suitable material with which to cover the playing board.

1

2

(2)

(ii) Give **two** reasons why varnish is a suitable finish for the playing board.

1

2

(2)



Leave blank

(c) The drawing below shows a question card holder from the board game.

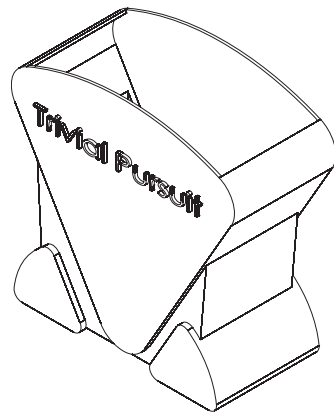

The question card holder is made from PVC.

Give **two** properties of PVC that make it a suitable material for the question card holder.

For each property give **one** reason why it makes PVC suitable.

Property

Reason

Property

Reason

(4)

(d) The drawing below shows one of the question cards used in the board game.



The question card is printed in full colour.

Quality control checks are carried out at important stages during the manufacture of the question card.

Name **two** important quality control checks that should be made during the manufacture of the question card.

1

2

(2)



Leave blank

(e) The drawings below show some of the playing parts used in the board game.

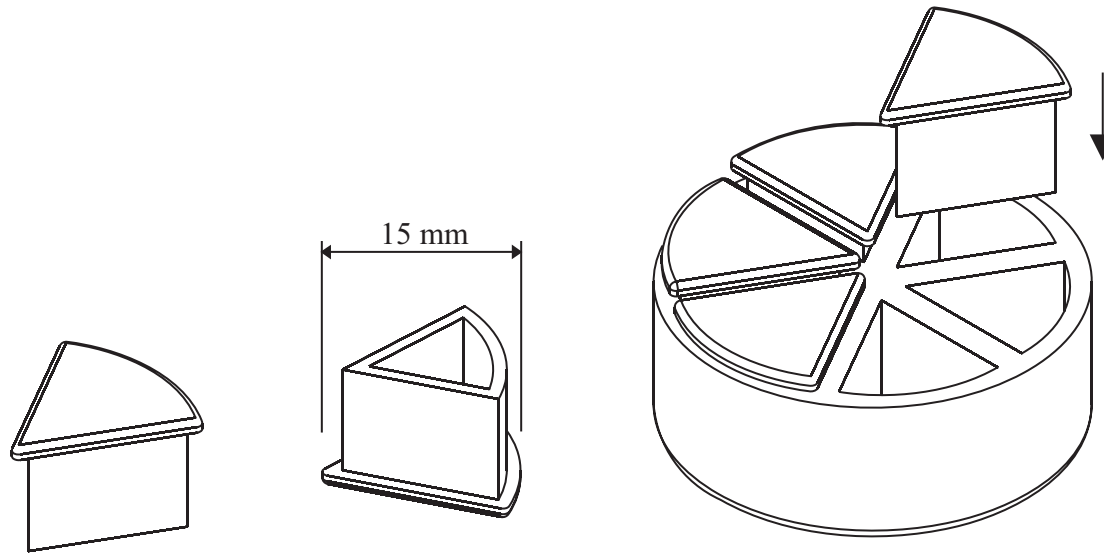

Top view of counter

Bottom view of counter

Counters in holder

The playing parts are made in high volume using the injection moulding process. The shapes of the playing parts make them suitable to be made using the injection moulding process.

Describe **one** way in which the shapes of the playing parts make them suitable to be made in high volume using the injection moulding process.

.....
.....

(2)



Leave
blank

(f) Two purposes of the board game are that it must be

- safe for users
- easy to store

Explain, under the following headings, how the board game achieves these purposes.

(i) Safe for users.

.....
.....
.....
.....

(2)

(ii) Easy to store.

.....
.....
.....
.....

(2)

(Total 22 marks)

Q1

7

Turn over



2. The drawings below show items produced to promote a musician.



T-Shirt



Wrist Band

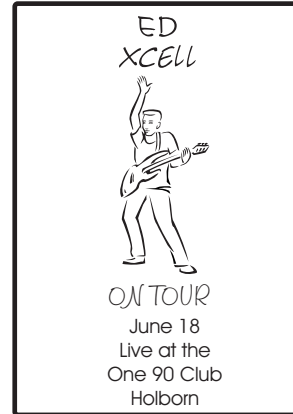

Souvenir Tour Poster

(a) (i) A graphic image is printed onto the fabric of the T-shirt.

Name **one** process suitable for printing the image onto the T-shirt.

.....
(1)

(ii) During the designing of the T-shirt, a glue stick was used to glue together different parts of the graphics that had been drawn onto paper.

Explain **one** reason why a glue stick might be used to glue the different parts of the graphics together.

.....
.....
(2)



Leave
blank

(b) (i) A scanner was used to scan images for the souvenir tour poster.

Describe **one** reason for scanning images.

.....
.....

(2)

(ii) The souvenir tour poster was printed using the gravure process.

Describe the surface of a gravure printing plate.

.....
.....

(2)

(iii) The souvenir tour poster is laminated before it is sold.

Explain **one** reason for laminating the poster.

.....
.....

(2)

(c) The wrist band is made from a material that can be stretched.

Give **two** reasons why tests would be carried out on the prototype of the wrist band.

1

2

(2)



(d) Products are manufactured using three different scales of production.

Complete the table below, giving the appropriate scale of production for the described product.

Description of product	Scale of production
Leaflets given away at a concert.	
A magazine about the band sold at newsagents nationally.	
A custom made vinyl sign.	

(3)

(e) The drawing below shows the net of a folder. The folder is sold to members of the fan club.

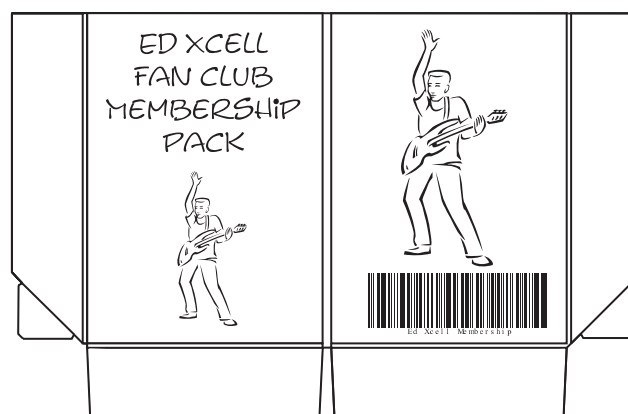

(i) The design for the folder was modelled in 2D using Computer Aided Design (CAD).

Explain **one** advantage of using CAD for 2D modelling.

.....

.....

(2)



Leave
blank

(ii) The folder is manufactured using an automatic production system.

Describe **one** way in which an automatic production system enables faster production.

.....
.....

(2)

(iii) The folder has a barcode printed on the back. EPOS tills are used to read information stored in the barcode.

Describe **one** way in which the information stored in the barcode is used.

.....
.....

(2)

(f) The fan club uses e-mail to communicate with its members.

Explain **one** advantage, for the fan club, of using e-mail to communicate with its members instead of posting letters to them.

.....
.....

(2)

Q2

(Total 22 marks)



3. The drawings below show a mobile phone. A point-of-sale display is required to display the phone in a shop.

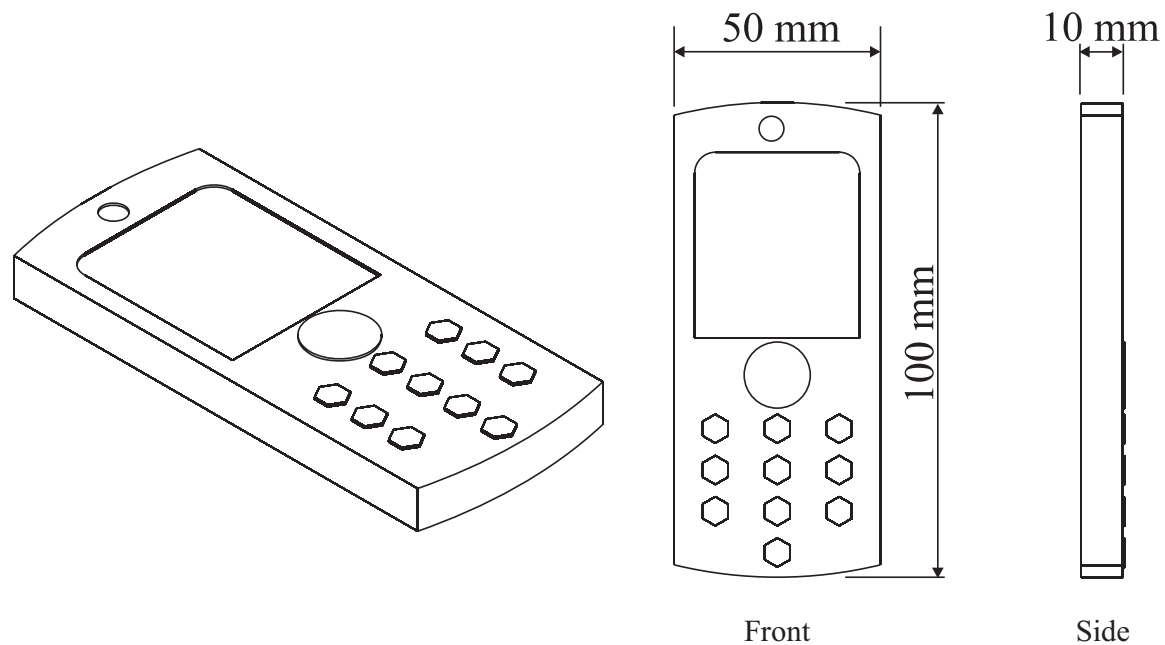

The specification for the point-of-sale display is that it must

- hold the mobile phone and allow it to be removed to look at
 - be supplied as a flat pack and assembled at the shop without the use of tools
 - have space to display a brand name and a price
 - be suitable for batch production materials and processes
- (a) In the spaces opposite, use sketches and, where necessary, brief notes to show **two different** design ideas for the point-of-sale display that meet this specification.

Do **not** evaluate your designs in part (a).

Candidates are reminded that if pencil is used for diagrams/sketches, it must be dark (HB or B). Coloured pens, pencils and highlighter pens must **not** be used.

PLEASE DO NOT WRITE OR DRAW IN THIS SPACE.

PLEASE USE THE SPACES OPPOSITE FOR YOUR DESIGNS.





<p>Design Idea 1</p>	<p>Leave blank</p>
<hr/> <p>Design Idea 2</p>	<p>(8)</p>

(8)

(8)



N 3 1 1 9 2 A 0 1 3 2 0



Leave
blank

(b) Three of the original specification points are repeated below.

Evaluate how one of your design ideas succeeds or fails to meet each of these specification points.

Write the number of your chosen design idea (1 or 2) here:

(i) Hold the mobile phone and allow it to be removed to look at.

.....
.....
.....
.....

(2)

(ii) Be supplied as a flat pack and assembled at the shop without the use of tools.

.....
.....
.....
.....

(2)

(iii) Be suitable for batch production materials and processes.

.....
.....
.....
.....

(2)

(Total 22 marks)

Q3



4. The drawings below show three prototype models of pencil cases. Each is made from a different material.

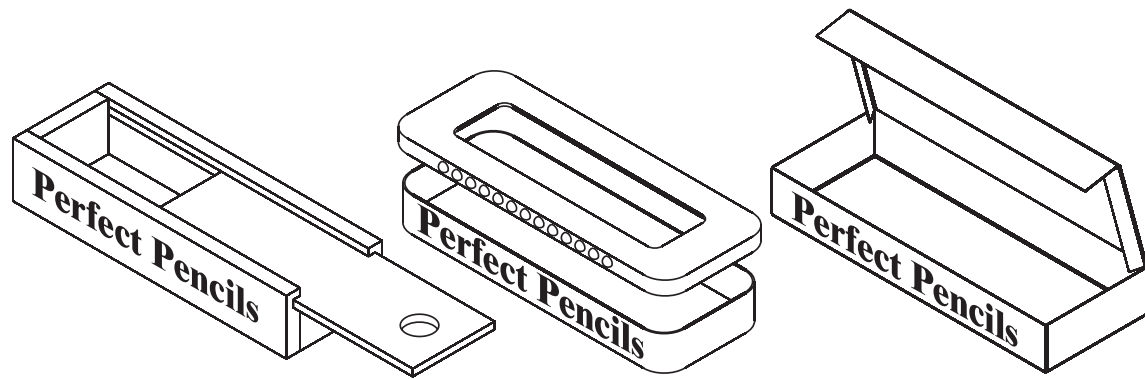

(a) The drawing below shows one prototype pencil case which is made from pine.

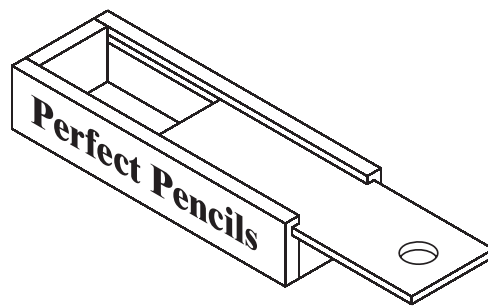

(i) State **one** advantage of making the prototype pencil case from pine instead of MDF.

..... (1)

(ii) The design for the prototype pencil case was produced using a drawing board and drawing equipment.

Explain **one** advantage of using a drawing board and drawing equipment rather than using CAD.

.....
..... (2)



(b) The drawing below shows another prototype pencil case which has a window in its lid. The window is made from acetate.

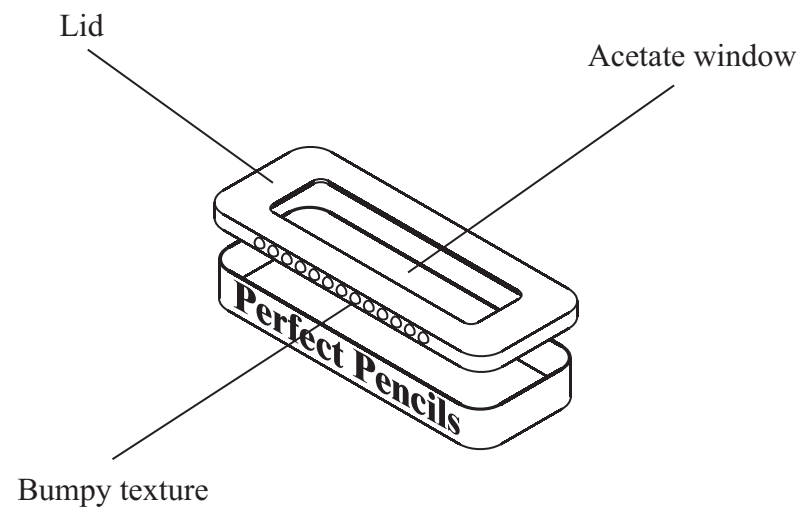

(i) Give **one** reason why acetate is a suitable material from which to make the window.

..... (1)

(ii) The lid of the pencil case has a bumpy texture applied to the sides.

Explain **one** reason why this bumpy texture is applied.

.....
..... (2)



(c) The drawings below show a third prototype pencil case and its net. The pencil case is made from polypropylene (PP) 0.5 mm thick.

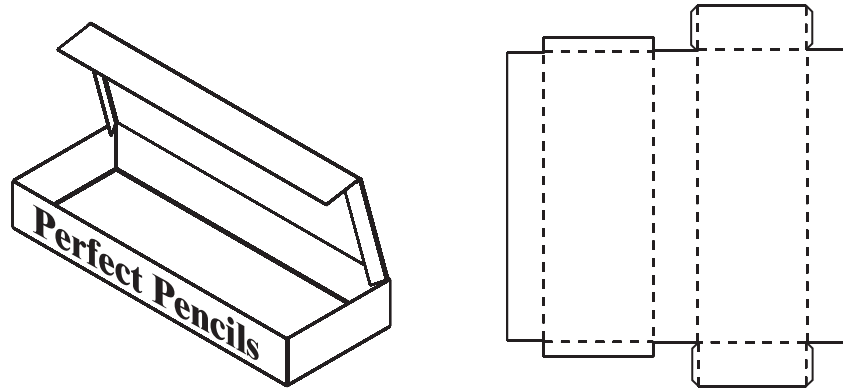

Net for case

(i) Give **one** reason why polypropylene is a suitable material from which to make this pencil case.

.....
(1)

(ii) The graphics on the prototype pencil case were applied using a fineline pen.

Describe **one** problem of applying graphics onto plastic using a fineline pen.

.....
.....
(2)

(iii) Explain **one** advantage, for a user, of increasing the thickness of the polypropylene to 0.75 mm.

.....
.....
(2)

(d) The pencil case is designed to be sold without any additional packaging surrounding it.

Explain **one** advantage to society of reducing product packaging.

.....
.....
(2)



Leave
blank

(e) Many products are manufactured to meet British Safety Standards.

(i) State **three** advantages, for the consumer, of products being manufactured to British Safety Standards.

1

2

3

(3)

(ii) Describe **one** disadvantage, for the consumer, of products being manufactured to British Safety Standards.

.....

.....

(2)

(f) E-mail is widely used for communication.

Explain **one** disadvantage of using e-mail for communication.

.....

.....

(2)

(g) Some products are promoted and sold as being in the latest fashionable style. When fashions change new versions are produced.

Describe **one** moral issue associated with replacing products due to changes in fashion.

.....

.....

(2)

Q4

(Total 22 marks)

TOTAL FOR PAPER: 88 MARKS

END



BLANK PAGE



BLANK PAGE

