



ASSESSMENT and
QUALIFICATIONS
ALLIANCE

General Certificate of Secondary Education

Design and Technology Systems and Control Technology (3546)

2008

Material accompanying this Specification

- Specimen Papers and Mark Schemes
- Reports on the Examination
- Teachers' Guide

SPECIFICATION

This specification will be published annually on the AQA Website (www.aqa.org.uk). If there are any changes to the specification centres will be notified in print as well as on the Website. The version on the Website is the definitive version of the specification.

| Vertical black lines indicate a significant change or addition to the specification published for 2007.

Further copies of this specification booklet are available from:

AQA Logistics Centre, Unit 2, Wheel Forge Way, Ashburton Park, Trafford Park, Manchester, M17 1EH.
Telephone: 0870 410 1036 Fax: 0161 953 1177

or

can be downloaded from the AQA Website: www.aqa.org.uk

Copyright © 2006 AQA and its licensors. All rights reserved.

COPYRIGHT

AQA retains the copyright on all its publications. However, registered centres for AQA are permitted to copy material from this booklet for their own internal use, with the following important exception: AQA cannot give permission to centres to photocopy any material that is acknowledged to a third party even for internal use within the centre.

Set and published by the Assessment and Qualifications Alliance.

Contents

Background Information

- | | | |
|---|--|---|
| 1 | The Revised General Certificate of Secondary Education | 5 |
| 2 | Specification at a Glance | 7 |
| 3 | Availability of Assessment Units and Entry Details | 8 |

Scheme of Assessment

- | | | |
|---|-----------------------|----|
| 4 | Introduction | 9 |
| 5 | Aims | 10 |
| 6 | Assessment Objectives | 11 |
| 7 | Scheme of Assessment | 12 |

Subject Content

- | | | |
|----|--|----|
| 8 | Summary of Subject Content | 14 |
| 9 | Designing and Making Skills | 15 |
| 10 | Subject Content: Core Technology | 17 |
| 11 | Subject Content: Focus Technologies –
Mechanisms and Pneumatics | 30 |

Key Skills and Other Issues

- | | | |
|----|--|----|
| 12 | Key Skills – Teaching, Developing and Providing
Opportunities for Generating Evidence | 33 |
|----|--|----|

13	Spiritual, Moral, Ethical, Social, Cultural and Other Issues	38
----	--	----

Centre-Assessed Component

14	Nature of the Centre-Assessed Component	39
----	---	----

15	Guidance on Setting the Centre-Assessed Component	41
----	---	----

16	Assessment Criteria	45
----	---------------------	----

17	Supervision and Authentication	50
----	--------------------------------	----

18	Standardisation	51
----	-----------------	----

19	Administrative Procedures	52
----	---------------------------	----

20	Moderation	54
----	------------	----

Awarding and Reporting

21	Grading, Shelf-Life and Re-Sits	55
----	---------------------------------	----

Appendices

A	Grade Descriptions	56
---	--------------------	----

B	Record Forms	58
---	--------------	----

C	Overlaps with Other Qualifications	63
---	------------------------------------	----

D	Project Assessment Matrix	64
---	---------------------------	----

Background Information

1

The Revised General Certificate of Secondary Education

Following a review of the National Curriculum requirements, and the establishment of the National Qualifications Framework, all the unitary awarding bodies have revised their GCSE syllabuses for examination in 2003 onwards.

1.1 Changes at GCSE

Key Skills

All GCSE specifications must identify, as appropriate, opportunities for generating evidence on which candidates may be assessed in the “main” Key Skills of communication, application of number and information technology at the appropriate level(s). Also, where appropriate, they must identify opportunities for developing and generating evidence for addressing the “wider” Key Skills of working with others, improving own learning and performance and problem solving. Design and Technology is uniquely placed to provide opportunities for all six Key Skills.

Spiritual, moral, ethical, social, cultural, environmental, health and safety and European Issues

All specifications must identify ways in which the study of the subject can contribute to an awareness and understanding of these issues.

ICT

The National Curriculum requires that students should be given opportunities to apply and develop their ICT capacity through the use of ICT tools to support their learning. In each specification candidates will be required to make effective use of ICT in ways appropriate to the needs of the subject.

Tiering

In most subjects the scheme of assessment must include question papers, targeted at two tiers of grades, ie A* - D and C - G.

A safety net of an allowed Grade E will be provided for candidates entered for the higher tier who just fail to achieve Grade D. The questions will still be targeted at A* - D.

Citizenship

From 2002, students in England have been required to study Citizenship as a National Curriculum subject. Each GCSE specification must signpost, where appropriate, opportunities for developing citizenship knowledge, skills and understanding.

1.2 Changes to the Design and Technology Criteria

The main changes to the Design and Technology criteria are given below.

- a. The Aims have been simplified to reflect the National Curriculum requirements, but it should be noted that they now include a consideration of the influences of past and present design and technology on society.
- b. The Assessment Objectives have been expanded.
 - AO1 consists of materials, components, processes, techniques and industrial practices.
 - AO2 combines designing and making into one objective.
 - AO3 evaluation of processes and products includes examining the wider effects of design and technology on society
- c. Greater emphasis has been placed on ICT, particularly CAD/CAM.

1.3 Changes to the Design and Technology (Systems and Control Technology) specification

The Design and Technology (Systems and Control Technology) specification has been substantially revised, modified and updated. It now offers a Core Technology (including Electronics Control) and a choice of two Focus Technologies: Mechanisms and Pneumatics.

2

Specification at a Glance

Design and Technology (Systems and Control Technology)

This specification is one of a suite of seven in Design and Technology offered by AQA. There are two tiers of assessment: Foundation (G-C) and Higher (D-A*).

GCSE 3546	
Written Paper	40% of total marks
Foundation Tier	2 hours
Higher Tier	2 hours
<p>Section A of the paper will contain compulsory questions which will test knowledge and understanding of the Core materials, processes, components and electronic control regardless of the candidate's choice of focus technology (mechanisms or pneumatics).</p> <p>Section B of the paper will contain one mechanisms question and one pneumatics question, and candidates must answer one of these questions, based upon their chosen area of study.</p> <p>A Preparation Sheet will be issued to centres at the beginning of February. It should be made available to candidates at the beginning of March. This sheet is common to the foundation and higher tier papers. It will give advance notice of the design context for some questions on the paper.</p>	
Coursework Project	60% of total marks not to exceed 40 hours
<p>Coursework will be internally assessed and externally moderated.</p> <p>Coursework consists of a project which addresses all the assessment objectives in an integrated way. The evidence required for the project consists of a 3-dimensional product and a concise design folder and/or the appropriate ICT evidence.</p> <p>It is expected that candidates will produce a final product using systems from the Core Technology, together with one of the two Focus Technologies.</p>	

Foundation Tier
3546F
Higher Tier
3546H

3

Availability of Assessment Units and Entry Details

3.1	Availability of Assessment Units	Examinations based on this Specification are available in the June examination series only.
3.2	Entry Codes	Normal entry requirements apply, but the following information should be noted. The Subject Code for entry to the GCSE award is 3546.
3.3	Classification Codes	Candidates may not enter for a GCSE full course and GCSE short course of the same title at the same sitting. Each specification is assigned to a national classification code, indicating the subject area to which it belongs. Centres should be aware that candidates who enter for more than one GCSE qualification with the same classification code, will have only one grade (the highest) counted for the purpose of the School and College Performance Tables. The classification code for this specification is 9060.
3.4	Private Candidates	This specification is not available for private candidates.
3.5	Access Arrangements and Special Consideration	AQA pays due regard to the provisions of the Disability Discrimination Act 1995 in its administration of this specification. Arrangements may be made to enable candidates with disabilities or other difficulties to access the assessment. An example of an access arrangement is the production of a Braille paper for a candidate with a visual impairment. Special consideration may be requested for candidates whose work has been affected by illness or other exceptional circumstances. Further details can be found in the Joint Council for Qualifications (JCQ) document: <i>Access Arrangements and Special Consideration</i> <i>Regulations and Guidance Relating to Candidates who are Eligible for Adjustments in Examination</i> <i>GCE, AEA, VCE, GCSE, GNVQ, Entry Level & Key Skills</i> This document can be viewed via the AQA web site (www.aqa.org.uk) Applications for access arrangements and special consideration should be submitted to AQA by the Examinations Officer at the centre.
3.6	Language of Examinations	All assessment will be through the medium of English. Assessment materials will not be provided in Welsh or Gaelge.

Scheme of Assessment

4

Introduction

4.1 National Criteria

This GCSE Design and Technology (Systems and Control Technology) specification complies with the following:

- The GCSE Subject Criteria for Design and Technology;
- The GCSE, GCSE in vocational subjects, GCE, VCE, GNVQ and AEA Code of Practice 2006/7;
- The GCSE Qualification Specific Criteria;
- The Arrangements for the Statutory Regulation of External Qualifications in England, Wales and Northern Ireland: Common Criteria;
- The National Curriculum Order for Design and Technology.

4.2 Rationale

This specification will enable candidates to acquire and apply skills in core technology systems, using electronic control. Candidates will also specialise in *one* focus technology, either Mechanisms or Pneumatics. They will learn about manufacturing processes, techniques and apply them as appropriate to the design and make process to produce quality control systems products.

4.3 Prior level of attainment and recommended prior learning

The specification builds on the Key Stage 3 programme of study for Design and Technology. It is expected that candidates will have followed this programme before commencing work on this specification.

It will be beneficial for candidates to have achieved at least Level 1 in the Key Skills of *Communication*, *Application of Number* and *Information Technology* to cope with the demands of this specification.

4.4 Progression

This qualification is a recognised part of the National Qualifications framework. As such, GCSE provides progression from Key Stage 3 through Key Stage 4 to post-16 studies. It lays an appropriate foundation for further study of Design and Technology.

Aims

A course based on this specification should encourage candidates to:

- a. demonstrate fully their design and technology capability, which requires them to combine skills with knowledge and understanding in order to design and make quality products in quantity;
- b. acquire and apply knowledge, skills and understanding through:
 - analysing and evaluating products and processes;
 - engaging in focused tasks to develop and demonstrate techniques;
 - engaging in strategies for developing ideas, planning and producing products;
 - considering how past and present design and technology, relevant to a designing and making context, affects society;
 - recognising the moral, cultural and environmental issues inherent in design and technology.

6

Assessment Objectives

6.1 Assessment Objectives

Candidates should be able to demonstrate their design and technology capability through acquiring and applying knowledge, skills and understanding:

- a. of materials, components, processes, techniques and industrial practice;
- b. when designing and making quality products in quantity;
- c. when evaluating processes and products and examining the wider effects of design and technology on society.

6.2 Quality of Written Communication

Where candidates are required to produce extended written material in English, they will be assessed on the quality of written communication. Candidates will be required to:

- present relevant information in a form that suits its purposes;
- ensure that text is legible and that spelling, punctuation and grammar are accurate, so that meaning is clear.

Quality of written communication will be assessed in candidates' coursework design folders.

Scheme of Assessment

7.1 Assessment Units

The Scheme of Assessment comprises two components.

Written Paper

40% of the marks

Foundation Tier	2 hours	125 marks
-----------------	---------	-----------

Higher Tier	2 hours	125 marks
-------------	---------	-----------

The Written Paper consists of two sections. All questions in Section A should be attempted. One question in Section B should be attempted.

Section A will test the application of knowledge and understanding of the Core materials, processes, components and electronic control regardless of the candidate's choice of focus technology. Section B will contain one mechanisms question and one pneumatics question and candidates must answer **one** of these questions, based upon their chosen area of study.

The evaluation of commercial practices and products will also be tested.

A Preparation Sheet will be issued to candidates at the beginning of March. This sheet is common to the foundation and higher tier papers and will give advance notice of the design context for some of the questions on the paper.

Coursework Project

40 hours

60% of the marks

95 marks

The coursework project will be internally assessed and externally moderated. Full details on coursework are given in Sections 14-16 below.

The project should address all three assessment objectives in an integrated way and should be in the area of Systems and Control Technology. Candidates are required to submit a concise design folder and/or the appropriate ICT evidence and a 3-dimensional outcome.

Throughout the project candidates should address the industrial and commercial practices, and the moral, social, cultural and environmental issues, arising from their work.

Experience has shown that candidates are often highly motivated where they devise their own project outlines. This is, therefore, to be encouraged and guidelines for the preparation of outlines are given in para 15.1. Examples of suitable project outlines are given in 15.2 which can also provide starting points for candidates.

Centres should ensure that candidates embark on projects that can satisfy the coursework requirements and be completed in 40 hours.

The assessment criteria in Section 16.3 should be used as a guide for teachers and candidates to the type of work and the standards required.

7.2 Weighting of Assessment Objectives

The approximate relationship between the relative percentage weighting of the Assessment Objectives (AOs) and the overall Scheme of Assessment is shown in the following table:

Assessment Objectives	Component Weightings (%)		Overall Weighting of AOs (%)
	Coursework	Written Paper	
1 Materials and Components	10	10	20
2 Designing and Making	40	20	60
3 Evaluation and Social Issues	10	10	20
Overall Weighting of Units (%)	60	40	100

Candidates' marks for each assessment unit are scaled to achieve the correct weightings.

Subject Content

8

Summary of Subject Content

9 Designing and Making Skills

Section 9 specifies the general designing and making skills required for both the full and short courses and the knowledge and understanding candidates should acquire.

10 Core Technology Content

Section 10 consists of the Core Technology subject content arranged under the following three broad headings:

Materials and Making Processes, Components and Control;
Design and Market Influences;
Industrial Processes and Manufacture.

11 Focus Technologies: Mechanisms and Pneumatics

Section 11 consists of the two Focus Technologies: Mechanisms and Pneumatics.

Designing and Making Skills

Design and Technology is a practical subject area which requires the application of knowledge and understanding when developing ideas, planning, producing products and evaluating them. The distinction between Designing and Making is a convenient one to make, but in practice the two often merge. For example, research can involve not only investigating printed matter and people's opinions, but also investigating e.g. proportions, adhesives, colour, structures, circuits and materials through practical work.

The skills which follow underpin all learning and cover the programme of study for KS4 Design and Technology.

9.1 Designing Skills

Candidates should be taught:

- to understand the basic design principles of line, form and colour and their application in designing;
- to develop and use design briefs, detailed specifications and criteria in relation to product development;
- to consider the conflicting demands that moral, cultural, economic, environmental, historical and social issues can make in the planning and in the designing of products;
- to consider their own health and safety and that of makers, manufacturers, individual users and society at large;
- to consider an increasing range of users of products and different societies in relation to their differing needs and values;
- to anticipate and design for product maintenance;
- to design for manufacturing in quantity;
- to plan for quality control and quality assurance when designing products and to be aware of the difference;
- to generate design proposals against stated design criteria, and to modify their proposals in the light of on-going analysis, evaluation and product development;
- to use graphic techniques and ICT, including CAD to generate, develop, model and communicate design proposals;
- to match materials and components with tools, equipment and processes, taking account of critical dimensions and tolerances when deciding how to manufacture the product;
- to produce and use detailed working schedules that will achieve the desired objectives in the time available, setting realistic deadlines for the various stages of manufacture, identifying critical points in the making process and providing alternatives to possible problems;

to devise and apply test procedures to check the quality of their work at critical points during development, and to indicate ways of modifying and improving it when necessary;

to be flexible and adaptable in their designing, in order to respond to problems, changing circumstances and new opportunities;

to ensure that the quality of their design solution will be suitable for intended clients and consumers;

to understand the difference between quality of design and quality of manufacture and use essential criteria to evaluate the quality of products they have made and products which have been made commercially;

9.2 Making Skills

Candidates should be taught:

to match materials and components with tools, equipment and processes to produce quality products;

to use tools and equipment safely, accurately and efficiently to achieve an appropriate fit, finish and reliable functioning in products that match their specifications;

to use a range of industrial applications when working with familiar materials and processes;

to manufacture products singly and in quantity, including the practical application of quality control and quality assurance techniques;

to use computer-aided manufacture (CAM) in single item production and in batch or volume production;

to simulate production and assembly lines including the use of ICT;

to be adaptable in their working practices, in order to respond to changing circumstances and new opportunities;

to ensure, through testing, modification and evaluation, that the quality of their products is suitable for intended users and devise modifications where necessary that would improve performance.

Core Technology

Materials and Making Processes, Components and Control

Candidates should build upon the National Curriculum Key Stage 3 Programmes of Study to develop a working knowledge of a range of materials and control systems appropriate to modelling, prototyping and manufacturing.

Knowledge and understanding of materials, making processes and components should be of sufficient depth for candidates to make an appropriate and reasoned choice when designing and making a control system.

The limited range of materials listed below is intended to define the areas of revision necessary for the examination, but it is expected that candidates will be able to show a general knowledge of the properties and characteristics of a wider range of materials, including textiles, through their coursework.

	Candidates should:	Possible learning experiences
10.1	Materials and Making Processes	
Materials	show a working knowledge of the following materials: acrylic, polystyrene, Medium Density Fibreboard (MDF), softwoods, mild steel, aluminium;	Create a reference database on the properties of these materials. Share it with other students, via the school Intranet.
Processes	describe in detail the following processes: vacuum forming, injection moulding;	Use vacuum forming in project work. Evaluate an injection moulded product supported by video of the process.
Manipulating materials	cut, shape and form materials to specific tolerances;	Use a variety of different materials for focused practical tasks.
Combining materials	describe how materials can be combined and processed to create more useful properties and how these changed materials are used in industrial applications;	Research how metals are combined to form ‘smart’ materials which can be used in robotics.
Preparing materials	prepare materials for manufacture, using standard components;	Prepare the edges of materials before jointing; use a solenoid as an output device.

	Candidates should:	Possible learning experiences
Applying finishes	use alternative finishes on the listed materials and justify their choice of finish in terms of function and aesthetics;	Carry out appropriate weatherproofing on product made of softwood if used in an outside location.
Optimum use of materials	use materials and components efficiently taking into account the nature of the material, the intended form and the manufacturing process to be used and eliminate as much wastage as possible;	As a group activity, measure the amount of waste materials for given tasks and suggest ways of reducing wastage.

10.2 Electronic Control - Components

Resistors and resistance	understand that resistors control voltage and current in electronic circuits;	
Capacitors	understand that capacitors store electrical charge;	Candidates will not have to be aware of the constructional details.
	use resistors (including LDRs, thermistors and potentiometers) and capacitors (including electrolytic and non-electrolytic);	Use LDRs and thermistors as input to a comparator circuit and resistor capacitor networks to control time constraints and frequencies.
Electronic building blocks	understand and use 555 monostable, 555 astable, 741 operational amplifiers in control situations;	
Potential dividers	use a potential divider to control input voltage in a circuit;	Build sensing circuits such as light and temperature.
	build a potential divider which will cause the voltage at V_s to rise in the following conditions: light, dark, hot, cold, wet and dry;	Use potential dividers as inputs to Peripheral Interface Controllers (PICs).
Switching	recognise and select the appropriate mechanical switch according to applications; use a transistor as a switch or an amplifier;	Evaluate switch use on a range of consumer products.

	Candidates should:	Possible learning experiences
Output devices	use motors, relays and solenoids appropriate to the Focus Technology being studied; understand when and why it is necessary to use a protective diode;	
Relays	show how a long voltage circuit can be interfaced with a mechanical system using relays, solenoids and motors; use relays in a variety of applications, including latching, reversing circuits; understand how a relay can be used as an electrically operated switch to switch and isolate a large current with a small one;	Use relays in a computer interface circuit to control motors.
Logic	understand that logic is used when circuits require more than one input; use the following logic gates and construct their truth tables (limited to 2 inputs): AND, OR, NAND, NOR, NOT; solve logic problems using gates in combination;	Use logic in control circuits. Use NAND gates when considering component redundancy and limiting stock requirements.
Programmable control	understand that ports have to be dedicated to input and output states; construct and run appropriate programs and use a control software package to control the inputs and outputs of a microprocessor; use decimal numbers to control the logic state of up to 8 outputs;	Test input bits and change output in response to state of input. Use computer software or write computer programs in a compatible language using such techniques as loops, sub-routines, scanning and any other appropriate techniques applicable to available systems. Demonstrate how PICs are used in domestic products such as microwave ovens and washing

	Candidates should:	Possible learning experiences
Peripheral Interface Controllers (PICs)	select erasable and non-erasable PICs for particular purposes;	Candidates write a programme for a washing cycle using a generic form of programming language, e.g. When input 1 goes high; Wait 10; Switch on output 1.
	explain the need for a ‘clock’ as part of the PIC circuitry;	Demonstrate or search catalogues to find different forms of erasable PICs, e.g. ultra-violet, electronic.
	use digital and analogue input sensors with PICs and identify the difference between analogue and digital signals;	Design a project board using a crystal oscillator.
	interface PICs with output devices which generate movement, including the use of transistors as transducer drivers;	Use potential dividers as input circuits for PICs.
Construction techniques	design and build electronic circuits of high quality using PCBs;	Use transistors, FETs and Relays to switch on outputs which require a higher current than the PIC can supply.
	use a variety of temporary and permanent construction techniques including breadboards and veroboards;	Evaluate similar circuits constructed using different techniques.
Input devices	use sensors, i.e. micro-switch, slotted opto-switch, reed switch, LDR, thermistor, mercury tilt switch, moisture sensor as input devices to control systems;	Attach sensors to a variety of models and program for feedback.
Calculations	use formulae identified on page 22 to calculate values;	

10.3 Component Symbols and Formulae

Component Symbols

understand the function of and use the components identified on page 21;

recognise the physical form of, and the electronic symbols given on page 21;

read and draw diagrams using the symbols identified in this specification and recognise their common physical form;

Gain experience of these during practical work, and designing of circuits.

Undertake fault finding procedures in pairs or groups, allowing candidates to alternate between reading the diagram and checking the system.

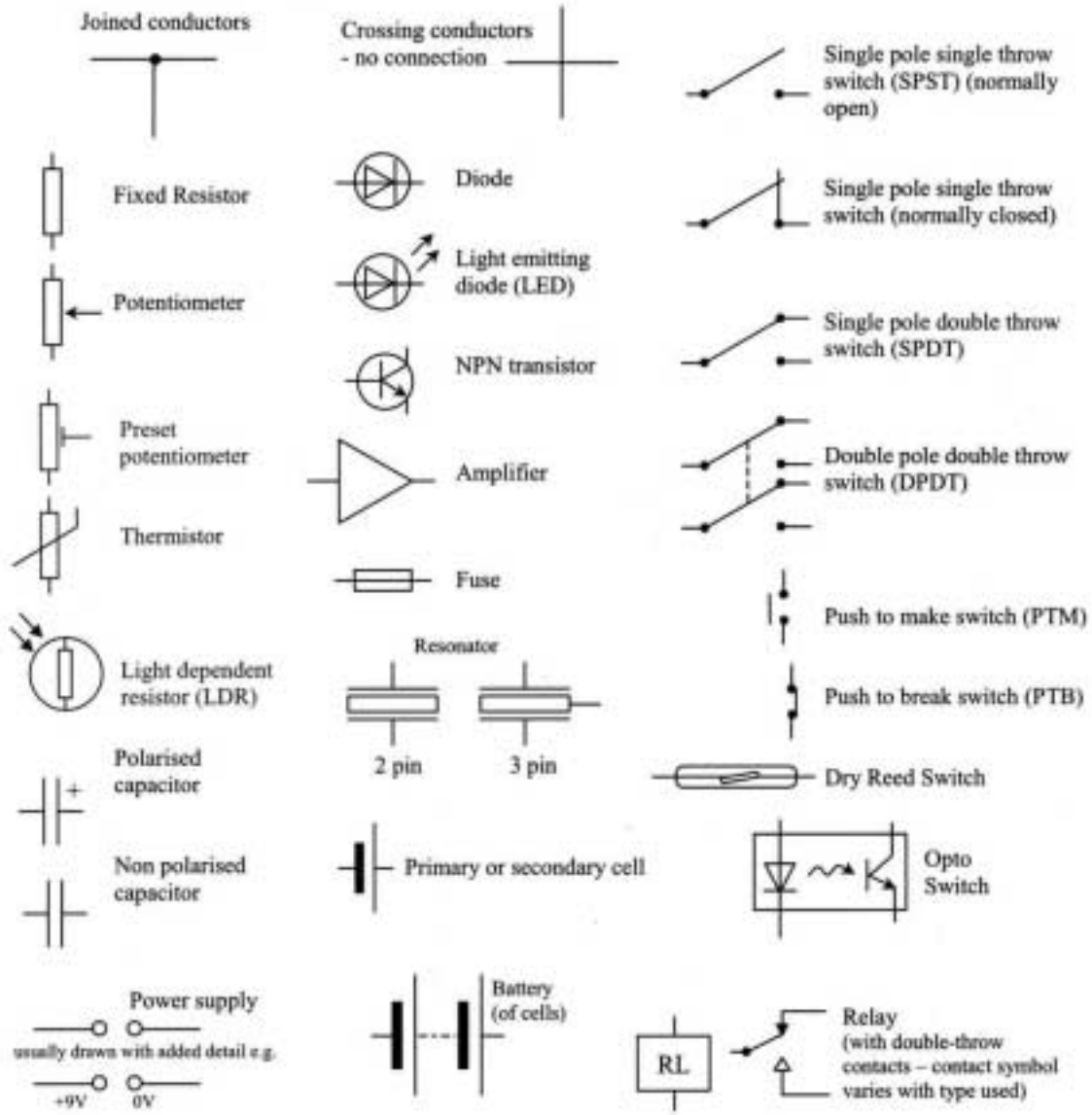

Note: Relay Symbol - The symbol consists of a relay coil and contacts. Contacts are usually drawn separate from the coil at convenient points on the circuit diagram and are always shown in the unoperated position.

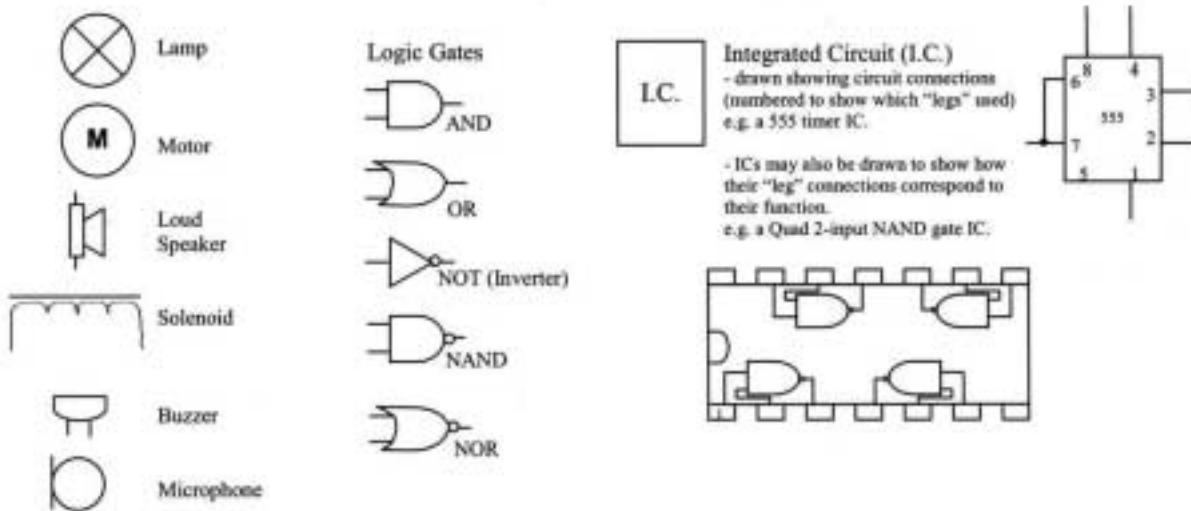

Formulae

Pneumatics	Force = Pressure × Area
Ratio of Simple Gears	$\text{Gear ratio} = \frac{\text{Number of teeth on driven gear}}{\text{Number of teeth on driver gear}}$
Velocity Ratio	$\text{Velocity Ratio} = \frac{\text{Diameter of driven pulley}}{\text{Diameter of driver pulley}}$

$$\text{Output speed} = \frac{\text{Input speed}}{\text{Gear/Velocity ratio}}$$

Forces	Moment = Force × Distance
	Sum of clockwise moments = sum of anti-clockwise moments.

Series Resistance	$R_T = R_1 + R_2 + R_3$
-------------------	-------------------------

Parallel Resistance	$\frac{1}{R_T} = \frac{1}{R_1} + \frac{1}{R_2} \text{ OR } R_T = \frac{R_1 \times R_2}{R_1 + R_2}$
---------------------	--

Potential Difference	$V = I \times R$
----------------------	------------------

Transistors	$\text{Current Gain} = \frac{\text{Collector Current}}{\text{Base Current}}$
-------------	--

Amplifier Gain	$A_v = \frac{\text{Change in output voltage}}{\text{Change in input voltage}}$
----------------	--

Area of circle	$A = \pi r^2$ (value of $\pi = 3.142$)
----------------	---

Resistor Colour Code			E12 Resistor preferred values
Colour	Number	Number of Zeros	10, 12, 15, 18, 22, 27, 33, 39, 47, 56, 68, 82 and decades thereafter.
Black	0		
Brown	1	0	
Red	2	00	
Orange	3	000	
Yellow	4	0,000	
Green	5	00,000	
Blue	6	000,000	
Violet	7	0,000,000	
Grey	8	00,000,000	
White	9	000,000,000	

Design and Market Influences

Candidates should be taught how to analyse systems control products and processes. They should consider how design and technology affects the manufacturer, user and environment, and the importance of health and safety issues.

Candidates should:

Possible learning experiences

10.4 Product Analysis

Analysis of designs and products

carry out product analysis through examining and disassembling a range of products;

As a group activity, disassemble a range of commercial products to analyse them.

Analysis of own product compared with alternatives on market

analyse the function and marketability of own product(s) through comparison with similar product(s) on market;

Analyse and evaluate own product(s).

10.5 Evaluation Techniques

Checking of design proposals against design criteria

understand the factors which influence the design of products;

Devise an end user evaluation of a prototype system.

Quality assurance through testing procedures

devise and apply test procedures to check the quality of their work at critical stages of development and modify for improvements of performance;

Make model/prototypes as work progresses, record the planning for continuous evaluation and testing, e.g. checking circuit function in stages.

detect and rectify simple faults by visual checks;

Identify faults during construction and on a complete circuit.

use a multimeter to check continuity, voltage and current;

Evaluation of quality of own product compared with market alternatives

test the quality of the end product against original specification to ensure that it is suitable for the intended users;

Research past and present commercial products to evaluate against own product, in terms of requirements of users, quality and costs.

	Candidates should:	Possible learning experiences
10.6 Social, Cultural, Moral and Environmental Issues		
Social and cultural influences on the consumer market	recognise the effects of social and cultural influences on product design;	Consider the role of the designer and the impact his/her designs may have on society and the environment. Research the effects control systems have had on various industries, e.g. motor and commerce.
Consumer choice	identify the factors involved in consumer choice; carry out market research to establish consumer preferences of target group(s) and ensure that own designs meet these requirements;	Look at professional market research questionnaire. Write questionnaire to establish consumer preferences and record these on spreadsheet / database. Ensure that own designs meet the requirements of the target market.
Product maintenance, consumer rights legislation and codes of practice	design for the maintenance needs of own product and be aware of current legislation concerning consumer rights and safety codes of practice when designing control systems; show awareness of the need for software licensing and the Data Protection Act;	Research care and maintenance labels for use on own product (clean, lubricate, keep dry, danger, this way up, check voltage etc.). Use specialist software packages to produce a small scale working circuit for eventual inclusion in a product and ensure that own design will not be used by others.
Moral and environmental issues	understand the moral and environmental changes brought about by the development of control technology; understand the harmful effects of industrial pollution and the crucial need to treat and dispose of waste materials correctly ; appreciate the importance of conservation and protection of natural resources and recycling;	As a group activity, discuss the increasing access to cheap reliable products due to the development of robotic production lines and the effects this has on employment. Research 'Green Technology' to protect the environment. Investigate the possibility of recycling systems control materials. Research the need to treat and dispose of certain systems control materials safely.

Candidates should:

Possible learning experiences

10.7 Health and Safety Issues

Identification and reduction of hazards and risks when designing and manufacturing SCT Products

understand that safety for the product maker and product user is essential;

assess hazard and risk factors in product manufacturing, choice and use of components, tools, equipment and work with these safely and effectively;

recognise hazards in products, activities and environments when working with electricity;

recognise the dangers and take precautions when using moving parts as part of a control system;

Discuss the health and safety implications of a product for the manufacturers and the end users.

Consider the need for safe working practices in the workshop, comfortable working positions, logic for safety switches, etc.

Research the dangers of heat and electricity when using a soldering iron. Discuss and record the relative danger of a variety of power supplies.

Discuss with other students, the safety features which could be incorporated into working projects. Be aware of safety features such as a belt slip in pulley systems.

Safety in working environment

recognise hazards, assess consequent risks and take steps to control the risks to themselves and others in a variety of workshop situations including: the use of tools, equipment and processes to manipulate resistant materials and construct control systems; distinguish between immediate and cumulative risks;

understand the following types of safety feature: fuses, earthing and pressure relief valves.

Conduct a formal hazard analysis in the school workshop.

Compare risks associated with working in dusty environments e.g. fire, respiratory.

Study the use of hazard/risk notices in various environments.

Industrial Processes and Manufacture

Candidates should be aware of, and use as appropriate, manufacturing processes and techniques, including CAD and CAM, for systems control products. They should have an industrial and commercial awareness and know about the systems processes involved in manufacturing for batch and mass production.

Candidates should:

Possible learning experiences

10.8 Systems and Control

The function and application of flow charts and symbol recognition

understand, explain and draw flow chart diagrams which describe a sequence of events, using the following symbols only;

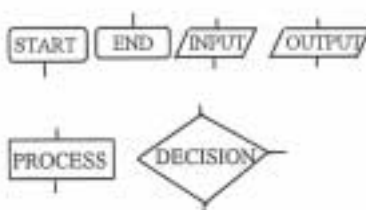

Discuss and review the use of flow charts in business and computer applications where actions have to be carried out in a particular order.

Sub-routine

Understand that the content of each “box” may be the result of a sub-routine or group of instructions;

Discuss the use of flow charts in fault finding activities.

Design, use and connection of control systems and sub-systems

design and set up a system and interconnect it with sub-systems to make a product, ensuring efficient use of time and energy and cost effectiveness;

Plan and produce flow charts to show logical and efficient sequences of work. Produce detailed working diagrams using CAD/CAM to ensure efficient use of time and energy when manufacturing a product.

Incorporation of feedback and checking procedures

understand and implement the concept of input-process-output and incorporate feedback loops to ensure that a system is working effectively and safely;

Suggest different types of feedback loops to incorporate in different systems; compare with systems feedback used in industry.

	Candidates should:	Possible learning experiences
Quality assurance through analysis and modification of system's performance	build into the system a series of critical checks to ensure that it works effectively to produce a quality product; continually test and evaluate own product at critical stages of manufacture to ensure quality and modify the system if necessary;	Produce prototypes of own designs and test against specification ; test, amend and modify prototypes of product to ensure that it meets the specification; keep control charts with relevant data and modifications at each stage in manufacture.

10.9 Information and Communication Technology

Computer technology and communication techniques	use ICT and software packages as appropriate to research, collect, sort and present research information;	Use the Internet. Present survey data using spreadsheets, charts and graphs.
Usage of CAD	use graphic techniques, including CAD, to generate, develop, modify, enhance, model and communicate design proposals and final specifications; understand and use CAD; use CAD software to aid planning for manufacture and to produce PCB track layouts;	Use CAD software packages when designing and manufacturing to develop/modify for sizes and dimensions. Make use of a digital camera. Use circuit symbols in conjunction with a graphics package to produce circuit diagrams for use in coursework projects. Develop suitable track layouts from circuit diagrams taking into account the requirements of the product as a whole.
Computer modelling techniques	use simple computer modelling techniques to test system proposals and circuit designs or calculate values in own product(s);	Use a computer modelling programme to test a circuit idea or a spreadsheet to write a programme which will give correct component values.
Usage of CAM	use CAM to enhance accuracy, efficiency and quality in the production of components and products;	Use the photo-etch or engraving methods to produce a PCB, e.g. to make a mask to be used in PCB production or use an engraver to cut appropriate cams. Use new technologies, e.g. a CNC milling machine to produce moulds for injection moulding, a CNC router to produce MDF moulds for vacuum-forming.

	Candidates should:	Possible learning experiences
10.10 Industrial Practices		
Industrial design and market awareness	<p>understand that clients, designers, manufacturers and users all have a role in the development of products for industrial manufacture;</p> <p>understand how new designs are developed prior to manufacture through consumer surveys, questionnaires, technological advances, etc.;</p>	<p>Research, as a group activity, these roles in the industrial context.</p> <p>Use questionnaires, surveys, CAD and CAM systems, brainstorming, specifications and test procedures when designing and making.</p>
Industrial applications and manufacturing systems	<p>prepare detailed production plans which reflect industrial practice, including scheduling, job sequencing and processing timescales and costs of production; use comparison with industrial system(s) to identify inefficiencies in own system and incorporate more efficient methods of batch/volume production;</p>	<p>Research an electronics company and observe control systems at work; watch a video showing the stages involved in rapid prototyping.</p> <p>Simulate a production line by setting up a small cell to produce PCBs; observe the efficiency of this system and suggest ways to improve it.</p>
Design for manufacture, batch and mass production	<p>anticipate the implications that the volume of production will have on the design of a product.</p>	<p>Research the use of simple jigs and fixtures to aid manufacture, when consistency in component size is required.</p>
Advertising and marketing	<p>understand the importance of advertising products; be aware of different distribution methods, i.e. shops, DIY stores, supermarkets, mail order catalogues and the Internet.</p>	<p>Suggest ways of marketing your product.</p>

Focus Technologies

Mechanisms

Candidates should select either Mechanisms or Pneumatics as their focus technology. The knowledge, understanding and acquired skills for their focus technology will be integrated with the core knowledge, understanding and skills for both the examination and the coursework.

Candidates should:

Possible learning experiences

11.1 Power Transmission

Systems

understand how mechanical systems can be used to change the speed, direction or distance of an output;

Model gears, cans and levers to produce different outputs.

Motion

identify and use the following types of motion when designing and making: rotary, oscillating, linear, and reciprocating;

explain how mechanical advantage can be gained;

Conduct experiments with pulleys.

Drive mechanisms

select and use mechanisms from the following range when designing and making and give examples of how they are used in industry;

Model simple lever mechanisms. Observe systems on common devices, e.g. workshop drill, bicycle.

levers;

Observe and get practical experience through the use of kits.

pulleys;

Use worm and wheel gears to reduce the output speed of a motor.

chairs and sprockets;

simple gear trains;

Show rack and pinion mechanism in use, e.g. on milling machine table.

compound gear trains;

worm and wheel gears;

rack and pinion gears;

cranks and sliders; cams and followers;

Show in use e.g. on power hacksaw, sketch simple plate cams and common followers, limited to knife, roller and flat.

test the suitability and dimensions of mechanical outputs;

Measure amplification of movement in a level and the speed of rotations of an output gear.







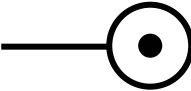
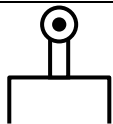

	Candidates should:	Possible learning experiences
Friction	explain and use lubrications, bushes and bearings to reduce friction;	Demonstrate various types of roller bearings and discuss their applications.
Calculations	use formulae identified on page 23 to calculate values;	Practice use of formulas through practical experimentation and theoretical calculation.

Pneumatics

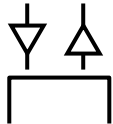
Candidates should select either Pneumatics or Mechanisms as their focus technology. The knowledge, understanding and acquired skills for their focus technology will be integrated with the core knowledge, understanding and skills for both the examination and the coursework.

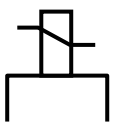
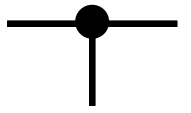
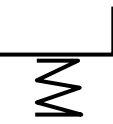
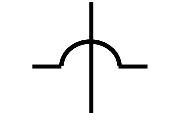
	Candidates should:	Possible learning experiences
11.2 Pneumatics		
Components	understand the function of components and use the components shown on page 32 when designing and making pneumatic systems;	Introduce appropriate symbols and diagrams as new components are used.
Control of motion	combine components to produce controlled motion of semi-automatic and automatic circuits;	Simulate industrial and everyday situations, e.g. press tool operation, car park barrier, sliding door, etc.
Logic functions	create an OR and AND function by using pneumatic components;	
Piston speed	combine flow regulators in design situations to control the speed of single and double acting cylinders.	Simulate industrial and everyday situations, e.g. the need to slow down the action of a closing door, etc.
Time delays	combine reservoir and flow regulators to delay the action of cylinders;	Simulate everyday and industrial situations, e.g. veneer press, car park barrier, etc.
Calculations	use formulae identified on page 23 to calculate values.	Use calculations when designing.

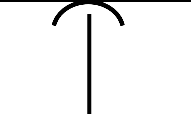
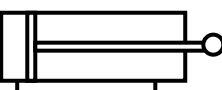
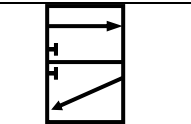
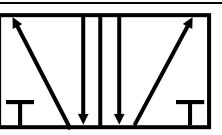
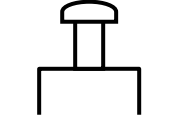
The following pneumatics symbols will be used in written examination questions.

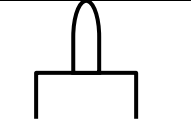
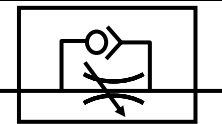
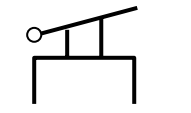
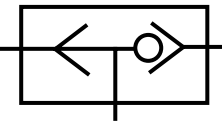
PNEUMATICS SYMBOLS & CONVENTIONS – the following are B.S./ISO standards which would be used when constructing pneumatic circuits			
	Main Air Supply		Roller Trip operation
	Exhaust Air		Pressure Sensitive/ Diaphragm operation
	Pilot Signal		Solenoid operation
	Air Pipes Connected		Spring Return
	Air Pipes crossing but unconnected		Single Acting Cylinder
	Air Bleed		Double Acting Cylinder
	3 Port Valve		5 Port Valve
	Push Button operation		Reservoir
	Plunger operation		Flow Regulator/ Unidirectional Flow Control Valve
	Lever operation		Shuttle Valve

Key Skills and Other Issues

12

Key Skills – Teaching, Developing and Providing Opportunities for Generating Evidence

12.1 Introduction

The Key Skills Qualification requires candidates to demonstrate levels of achievement in the Key Skills of *Application of Number, Communication and Information Technology*.

The units for the ‘wider’ Key Skills of *Improving own Learning and Performance, Working with Others* and *Problem-Solving* are also available. The acquisition and demonstration of ability in these ‘wider’ Key Skills is deemed highly desirable for all candidates, but they do not form part of the Key Skills Qualification. Design and Technology, however, does offer a unique opportunity for candidates to provide evidence for all six Key Skills.

Copies of the Key Skills Units may be downloaded from the QCA Website (<http://www.qca.org.uk/keyskills>).

The units for each Key Skill comprise three sections:

- A What you need to know.
- B What you must do.
- C Guidance.

Candidates following a course of study based on this Specification for Design and Technology (Systems and Control Technology) can be offered opportunities to develop and generate evidence of attainment in aspects of the Key Skills of *Application of Number, Communication, Information Technology, Improving own Learning and Performance, Working with Others* and *Problem-Solving*. Areas of study and learning that can be used to encourage the acquisition and use of Key Skills, and to provide opportunities to generate evidence for Part B of the units, are signposted below.

12.2 Key Skills Opportunities in Design and Technology (Systems & Control Technology)

The broad and multi-disciplinary nature of Design and Technology makes it an ideal vehicle to help candidates develop their knowledge and understanding of all Key Skills and to produce evidence of their application. It should be noted that, while *Working with Others* is an important aspect of Design and Technology, the work candidates submit for coursework assessment must be their own.

Application of Number Level 1

What you must do ...	Signposting of Opportunities for Generating Evidence in Subject Content
N1.1 Interpret information from different sources	9.1, 10.1, 10.3, 11.1, 11.2
N1.2 Carry out calculations	10.1, 10.2, 11.1, 11.2
N1.3 Interpret results and present findings	9.1, 10.4, 10.6

Application of Number Level 2

What you must do ...	Signposting of Opportunities for Generating Evidence in Subject Content
N2.1 Interpret information from different sources	9.1, 10.1, 10.3, 11.1, 11.2
N2.2 Carry out calculations	10.1, 10.2, 11.1, 11.2
N2.3 Interpret results and present findings	9.1, 10.4, 10.6

Communication Level 1

What you must do ...	Signposting of Opportunities for Generating Evidence in Subject Content
C1.1 Take part in discussions	9.1, 10.1, 10.6
C1.2 Read and obtain information	9.1, 10.1 – 11.2
C1.3 Write different types of documents	9.1, 10.1, 10.2, 10.6

Communication Level 2

What you must do ...	Signposting of Opportunities for Generating Evidence in Subject Content
C2.1a Contribute to discussions	9.1, 10.1, 10.6
C2.1b Give a short talk	10.6
C2.2 Read and summarise information	9.1, 10.1 – 11.2
C2.3 Write different types of documents	9.1, 10.1, 10.2, 10.6

Information Technology Level 1

What you must do ...	Signposting of Opportunities for Generating Evidence in Subject Content
IT1.1 Find, explore and develop information	9.1, 10.9
IT1.2 Present information, including text, numbers and images	9.1, 10.8, 10.9

Information Technology Level 2

What you must do ...	Signposting of Opportunities for Generating Evidence in Subject Content
IT2.1 Search for and select information	9.1, 10.9
IT2.2 Explore and develop information and derive new information	9.1, 10.8, 10.9
IT2.3 Present combined information, including text, numbers and images	9.1, 10.8, 10.9

Working with Others Level 1

What you must do ...	Signposting of Opportunities for Generating Evidence in Subject Content
WO1.1 Confirm what needs to be done and who is to do it	9.1, 10.1, 10.2
WO1.2 Work towards agreed objectives	9.1, 10.5, 10.6, 10.7
WO1.3 Identify progress and suggest improvements	9.1, 10.5, 10.8

Working with Others Level 2

What you must do ...	Signposting of Opportunities for Generating Evidence in Subject Content
WO2.1 Plan work and confirm working arrangements	9.1, 10.1, 10.2
WO2.2 Work cooperatively towards achieving identified objectives	9.1, 10.5, 10.6, 10.7
WO2.3 Exchange information on progress and agree ways of improving work with others	9.1, 10.5, 10.8

Improving own Learning and Performance Level 1

What you must do ...	Signposting of Opportunities for Generating Evidence in Subject Content
LP1.1 Confirm, short term targets and plan how these will be met	9.1, 10.1
LP1.2 Follow plan to meet targets and improve performance	9.1, 10.2, 10.4, 10.5
LP1.3 Review progress and achievement.	9.1, 10.5, 10.8

Improving Own Learning and Performance Level 2

What you must do ...	Signposting of Opportunities for Generating Evidence in Subject Content
LP2.1 Help set short-term targets and plan how these will be met	9.1, 10.1
LP2.2 Use plan and support from others, to meet targets	9.1, 10.2, 10.4, 10.5
LP2.3 Review progress and identify evidence of achievements	9.1, 10.5, 10.8

Problem Solving Level 1

What you must do ...	Signposting of Opportunities for Generating Evidence in Subject Content
PS1.1 Confirm understanding of given problems	9.1, 10.1 – 11.2
PS1.2 Plan and try out ways of solving problems	9.1, 10.1, 10.5
PS1.3 Check if problems have been solved and describe the results	9.1, 9.2, 10.2, 10.5

Problem Solving Level 2

What you must do ...	Signposting of Opportunities for Generating Evidence in Subject Content
PS2.1 Identify problems and come up with ways of solving them	9.1, 10.1 – 11.2
PS2.2 Plan and try out options	9.1, 10.1, 10.5
PS2.3 Apply given methods to check if problems have been solved and describe the results	9.1, 9.2, 10.2, 10.5

12.3 Further Guidance

More specific guidance and examples of tasks that can provide evidence of single Key Skills, or composite tasks that can provide evidence of more than one Key Skill are given in the AQA specification support material, particularly the Teachers' Guide.

13

Spiritual, Moral, Ethical, Social, Cultural and Other Issues

-
- 13.1 Spiritual, Moral, Ethical, Social, Cultural and Other Issues**
- The study of design and technology should contribute substantially to candidates' understanding of moral, ethical, social and cultural issues. Such issues underlie all design and manufacturing activities and are explicitly referred to in paragraphs 9.1 to 11.2 of the Subject Content. These issues will be tested in all coursework and the written paper.
-
- 13.2 European Dimension**
- AQA has taken account of the 1988 Resolution of the Council of the European Community in preparing this specification and associated specimen papers.
-
- 13.3 Environmental Issues**
- AQA has taken account of the 1988 Resolution of the Council of the European Community and the Report "*Environmental Responsibility: An Agenda for Further and Higher Education*" 1993 in preparing this specification and associated specimen papers.
- Environmental considerations are important to the development of all designs and products. Awareness of these issues is specifically required in all sections of the Subject Content and will be tested in all components. See Sections 14 and 15 for details of coursework requirements.
-
- 13.4 Citizenship**
- In the Key Stage 4 programme of study for Citizenship, *Developing skills of enquiry and communication* (Section 2) and *Developing skills of participation and responsible action* (Section 3) naturally parallel candidates' actions and approaches during project work. For example, the effects of certain products or manufacturing systems on society and the individual are matters of interest in design and technology, but they also touch on Section 2(a) of the Citizenship programme of study. Similarly, the designer needs to empathise with the end user (Section 3(a)) and in the process of designing needs to negotiate with clients or during market research to determine and achieve the desired ends (Section 3(b)).
-
- 13.5 Avoidance of Bias**
- AQA has taken great care in the preparation of this specification and associated specimen papers to avoid bias of any kind.
-
- 13.6 Health and Safety**
- Health and Safety impinges on all aspects of Design and Technology and requires consideration in terms of the maker, the manufacturer, the individual user and society at large. Health and Safety and related issues should therefore be an integral part of all teaching. They are expected to be considered in coursework and will also be tested in the written paper.
-

Centre-Assessed Component

14

Nature of the Centre-Assessed Component

14.1 The nature of Design and Technology

The distinguishing feature of any design and technology course is its practical nature. Knowledge and understanding is not therefore to be acquired purely for its own sake, but in order to satisfy the needs of clients and consumers, and the constraints placed on manufacturers in industrial and commercial contexts.

For Systems and Control Technology, candidates will need to be familiar with a range of electronic control systems and material areas and the use of CAD/CAM in production. They will also specialise in **one** of either Mechanisms or Pneumatics or a mixture of both for coursework projects.

It is important to note that two or more process blocks should be used if candidates wish to access the highest grades.

Underpinning all learning are the designing, communication and making skills which make use of knowledge and understanding in order to produce outcomes which satisfy a design brief.

Designing

Designing is a process based activity involving the progressive engagement with a problem which requires thinking, creating, inventing, predicting, experimenting, decision making, constant evaluation and, where necessary, modification. Designers develop an awareness of the opportunities and constraints placed upon them by taking account of the demands of users and producers, market forces and the effects their products can have on society and the environment.

The activities detailed above draw upon relevant skills and knowledge which are enriched by the application of human values.

Making

The realisation of design ideas and solutions to problems is achieved by making products where a range of materials and media may be used. In design and technology, making activities may take many forms, ranging through early experimentation, testing and trials to a final marketable product. All the aspects detailed above provide opportunities for students to develop making skills as they seek to produce high quality outcomes.

Communication

Communication is an integral aspect of the whole process and it plays three major roles in any design and technology activity.

First, it enables the designer to visualise ideas and thoughts which permit detailed analysis. Second, it provides a record which can be referred to, adapted or refined as the process progresses. Third, it provides an explanation for others of the development of ideas from the mind to the outcome.

The range of communication methods is wide and becoming wider through the increasing use of ICT. All or any should be used *as appropriate to the task in hand* – notes, sketches, formal drawings, photographs, computer programs, oral communication and two or three dimensional representations are all relevant in particular circumstances.

14.2 The Coursework Project

Candidates are required to submit a single integrated project which consists of a *concise* design folder and/or appropriate ICT evidence and a 3-dimensional outcome. Candidates are encouraged to produce coursework which shows how one or more different technologies taken from the Core and the chosen Focus Technology can be integrated into one product. Candidates should be made aware that two or more process blocks must be used for access to the highest grades.

The whole activity should not exceed 40 hours.

GCSE Design and Technology involves increased emphasis on the industrial aspects of designing and making, particularly in the use of CAD/CAM, and on the wider effects of technological activity on society and the environment. These elements should therefore be evident in candidates' projects.

Candidates wishing to work with others may do so. Centres must ensure, however, that candidates select appropriate projects and provide individual and separate evidence of their own ability to design and make a quality product from start to finish.

Candidates may use the Board-set project outlines given in paragraph 15.2 below, formulate their own briefs or use briefs set by the centre. The centre is responsible for ensuring candidates attempt projects which satisfy the coursework requirements (see Section 15 below).

Candidates may enter for any other GCSE specification at the same sitting. However the submission of the same piece of coursework for more than one specification is prohibited.

Guidance on Setting the Centre-Assessed Component

15.1 Project Outlines

Project outlines are given below for Design and Technology (Systems and Control Technology). Centres may use these or adapt them to meet the needs of their candidates. Centres wishing to develop their own outlines for candidates should take note of the following guidelines.

The checklist below is given to help teachers ensure that the project outlines they prepare will meet both the needs of candidates and the requirements of the specification. Prior approval of centre devised project outlines is not required.

- a. Does the outline encourage an integrated approach to designing and making and represent a *level of demand* appropriate to the individual candidate's ability?
- b. Has the outline or problem been so written that candidates will be able to demonstrate the highest level of their ability in each Assessment Objective?
- c. Where a single outline is to be presented to a number of candidates covering a wide ability range, has each candidate produced a brief for him/herself that will be challenging, but not daunting?
- d. Does the project offer the scope to integrate several different technologies?
- e.
 - Does the project outline offer scope for candidates to consider:
 - the effects and implications of technological activity (e.g. industrial, social, moral, cultural, economic, environmental factors);
 - systems and control;
 - provision for product maintenance;
 - repetition skills (e.g. multiple production);
 - use of CAD/CAM and ICT skills in general;
 - product quality;
 - health and safety in relation to the maker and others?
- f. Are the resources, equipment, tools, materials and media available for the potential demands of the project?
- g. Can the project be completed satisfactorily in 40 hours?

- h. Will the task permit sufficient supervision to enable the teacher to certify that the candidate's work is his/her own?

Where candidates work with others, it must be possible to identify the individual contribution of each candidate, so that the requirements in the specification are met.

- i. Is the project outline free from political, ethnic, gender and other forms of bias?

15.2 List of Project Outlines

The following list of possible projects is provided as a starting point for candidates. Candidates may use these, adapt them or devise their own.

1. Pupils in Nursery or Primary Schools use play as a means of learning. Such activity often involves using educational toys. Design and make a suitable learning toy for a child, that uses some form of safe control system.
2. Picking up small objects which are inaccessible, or are located in a hostile environment, can be difficult. Design and make a remote arm or a gripper device for a particular situation. The product will be batch produced.
3. A local pet shop wishes to sell a range of devices that will automatically feed small-cage pets (such as rabbits, gerbils, mice etc) when their owners are away for the weekend. Design and build a prototype device that could satisfy this need. The product will be batch produced.
4. Monitoring and recording weather conditions are part of many schools' Geography practical work. Design and build a device which could satisfy this need.
5. Partially-sighted and blind people find many cooking activities difficult. You have been asked to design and build a set of kitchen scales that could be used by such people, and can be produced in quantity.
6. Geography students need to measure the flow rate of a local river at different depths across its width. You have been asked to design and build a flow meter that could be used on a field trip.
7. A small electronics firm wishes to develop a range of portable alarm systems for particular groups of people. Design and make a prototype suitable for development by the company.
8. Your local model boat club wants you to design and make a wave tank that can be used to evaluate different hull designs. This product will be marketed and sold nationally.
9. The manager of a local "super store" has asked you to design a promotional display for the entrance to the store that can be used to promote a product of your choice. The display needs to be interactive, so it will operate when someone enters the store or stands in front of the display. You have been asked to design and make a working model of this, to show how it will work.

10. Your local primary school has asked you to design and make a working model of a pedestrian crossing with traffic lights, so it can be used to teach young children how to use the lights to cross the road safely. The ergonomics of this problem could be considered as part of the project.
11. The dining room at a local school becomes over-crowded because there is no system to control when pupils enter or leave. Design a control system that can monitor numbers of pupils as they enter and leave the dining room and will indicate which year group should enter next. You should consider health and safety issues and a manual override, so lunchtime supervisors can take control if necessary.
12. Identify a location where an internal door needs to be locked. Design a lock system for the door that can be opened and closed without the need for people to carry a key with them. The system will be marketed nationally.
13. Many young children have access to a computer at home. Design an educational or interactive toy that can be connected to the computer.
14. When cycling some riders, especially young children, find it difficult to understand how they should use the gears. Design and make a device that could be fitted to a bicycle that could help indicate when the rider should change gear. This device is to be sold in quantity.
15. Manufacturing companies must carry out extensive tests on products, to ensure they work reliably before they are sold. Identify a suitable product and design and make a test rig that could be used to ensure it will work correctly over an extended period of time.
16. Identify a situation where a stable environment is important. Design and make a model control system to show how this environment can be stabilised. Ventilation, temperature, brightness and air humidity are all important in this type of system.
17. When using any form of training equipment in a gym it is important to monitor your performance, record the number of “reps” or inform the user when they have completed the required number of “reps”. Identify one exercise or piece of equipment. Design and make a device that will help the athletes in their training.
18. Musicians need to turn the pages of musical scores during a performance. They cannot always do this as they use both hands playing their instrument. Design and make a device that will overcome this problem. It will be marketed nationally.
19. Many companies use a computerised storage and identification system in their warehouses. Design and make a model to show how a system like this would work.
20. A local transport museum has asked you to design and make a model of a canal lock system to inform visitors how this works. They will display this in the museum entrance
21. Local table tennis players have asked you to design and make a device that will serve balls to them so they can practice playing without an opponent. Some form of random delivery needs to be considered in the design of the device. If successful, it will be marketed nationally.

22. A local courier service has asked you to look at the problem of sorting parcels of different weights. They want you to design and make a working model of a system that could automatically sort a range of parcels by their weight.

15.3 Support Material

Further examples of project outlines are included in the *Teachers' Guide*. Other material to support teachers will be produced for the annual teachers' meetings in the Autumn Term.

15.4 Coursework Advisers

Coursework Advisers will be available to assist centres with any matters relating to coursework. Details will be provided when AQA knows which centres are following the specification.

16

Assessment Criteria

16.1 Introduction

Teachers are required to determine grades separately for the designing and making elements of their candidates' coursework. To do this they must use their professional judgement in conjunction with the Assessment Criteria given in 16.3 below.

The level of demand of a design brief should influence the interpretation of the criteria. A successful project which makes great demands on skills, cognitive abilities and breadth and depth of knowledge should be more highly rewarded than a successful project with fewer demanding aspects.

Quality of work is more important than quantity and size. For this reason no estimate of the number of pages in a design folio or of the size and complexity of the product is given. Candidates should, however, plan to produce *concise* design folders and 3D outcomes which can reasonably be completed, in total, in no more than 40 hours. Candidates who do not complete their projects will be assessed on what they submit.

Candidates wishing to work with others may do so. Centres must ensure, however, that candidates select appropriate projects and provide individual and separate evidence of their own ability to design and make a quality product from start to finish.

The Assessment Criteria give guidance on the expected levels of achievement in Designing Skills and Making Skills for grades G-A. Teachers should note that A* does not feature as a coursework grade. A* grades are determined arithmetically on the total marks gained for the examination and are available only for candidates who have taken a Higher Tier paper.

As in any holistic assessment, a weak performance in one aspect of a candidate's work may be balanced by a strong performance in another. The principle of "best fit" should be applied when using these criteria.

An assessment of the quality of written communication in the design folder is to be made according to the criteria given in 16.4.

Centres are strongly recommended to provide candidates with feedback as their work progresses. This can not only encourage or reward the candidates, but it can also ease the assessment burden on teachers at the end of the coursework period.

Teachers should not record their comment on candidates' work; any written comments should be recorded on the Candidate Record Form.

16.2 Assessment Procedure

An assessment of a candidate's coursework should follow the pattern given below.

- a. Guided by the criteria, assess the Designing Skills in terms of a whole grade, e.g. Grade C.
- b. Refine that decision to High (H), Middle (M) or Low (L). A candidate only just achieving the required standard should be given the lowest assessment in the grade, (L), while a candidate just failing to reach the grade above should be given the highest in the grade (H).
- c. Repeat a. and b. above for Making Skills.
- d. Record the refined grade for Designing (e.g. High B = HB) and the refined grade for Making (e.g. Mid E = ME) on page 4 of the Candidate Record Form.
- e. Using the *Project Assessment Matrix* (Appendix E), derive from the two grade decisions a single mark. For example, a High B for Designing and a Mid E for Making will produce a mark of 52.
- f. Record the mark derived from the matrix in the space on page 4.
- g. Using the criteria below, make an overall assessment of candidates' completed design folders for the quality of written communication (QWC) and determine a mark out of a maximum of 5 marks.
- h. Record the QWC mark in the space provided on page 4.
- i. Add together the Matrix mark and the QWC mark and write the total out of 95 in the Total Mark box.
- j. The total mark for each candidate is to be recorded on the AQA mark sheet which will be sent to centres in the Spring Term.

16.3 Assessment Criteria Candidates will have:

Grade	Designing	Making
G	<ol style="list-style-type: none"> gathered minimal research information; provided little evidence of analysis of task or research; produced a simple specification; produced a solution, with rudimentary forward planning; attempted a superficial evaluation of the outcome of their work; demonstrated very limited communication, graphical and ICT skills; provided little or no evidence of having considered industrial practices and systems and control. 	<ol style="list-style-type: none"> used materials, components and equipment safely under close supervision; produced references to the use of CAM where appropriate; produced an undemanding or incomplete outcome; some evidence of QA and QC.
F	<ol style="list-style-type: none"> used more than one source to gather research information; made a limited attempt to analyse the task and the research material; produced a generalised specification; produced at least two proposals which satisfy parts of the specification; used a proposal to produce the outcome with little development and forward planning; superficially tested and evaluated their work against original intentions; demonstrated limited communication, graphical and ICT skills; provided limited evidence of having considered industrial practices and systems and control. 	<ol style="list-style-type: none"> used materials, components and equipment correctly and safely (including CAM if appropriate); produced a largely complete but undemanding outcome; demonstrated accuracy and finish in some parts of the product; produced evidence of some QA and QC.
E	<ol style="list-style-type: none"> used a limited number of sources to gather research information; made a superficial analysis of the task and most of the research material; produced a specification which reflects the most obvious features of the analysis; produced some proposals which satisfy most of the specification; used their proposals and relevant knowledge to produce a solution which satisfies most of the specification; demonstrated some forward planning; tested and evaluated some aspects of their work; used some appropriate communication, graphical and ICT skills to convey design ideas; provided limited evidence of having considered industrial practices and systems and control. 	<ol style="list-style-type: none"> corrected working errors where necessary; used materials, components, equipment and processes correctly and safely (including CAM if appropriate); produced a largely complete and largely effective outcome; demonstrated a fair degree of accuracy and finish in the overall product; applied QA and QC broadly but superficially.
D	<ol style="list-style-type: none"> used several appropriate sources to gather relevant research information; made a simple analysis of the task and all research material; produced a specification which reflects most of the analysis; produced several proposals which satisfy the specification; used their proposals and relevant knowledge to develop a solution which satisfies the specification; planned sequence of making activities; tested and evaluated most aspects of their work and made some appropriate modifications; used appropriate communication, graphical and ICT skills to convey design ideas; provided limited evidence of having considered relevant industrial practices and systems and control. 	<ol style="list-style-type: none"> appropriately corrected working errors; used appropriate materials, components, equipment and processes correctly and safely (including CAM); produced an effective and largely complete outcome; demonstrated a reasonable level of accuracy and finish in the product; applied QA and QC broadly.

Candidates will have:

Grade	Designing	Making
C	<ol style="list-style-type: none"> used a variety of appropriate sources to gather and order relevant research information; analysed the task and the research material; produced a specification which reflects the analysis; produced a range of proposals which satisfy the specification; used their proposals and relevant knowledge to develop a detailed design solution which satisfies the specification; planned a largely correct, and workable, sequence of main making activities; tested, evaluated and modified their work throughout the process as appropriate; used a range of communication, graphical and ICT skills sufficient to convey ideas to themselves and others; provided evidence of having considered relevant issues, industrial practices and systems and control. 	<ol style="list-style-type: none"> recognised the need for and justified any changes or adaptations; used appropriate materials, components, tools, equipment and processes (including CAM) correctly and safely; produced a complete, effective and well-assembled outcome; demonstrated a level of accuracy and finish in the product which satisfies most of the demands of the design solution; clearly used QA and QC to control quality in most activities.
B	<ol style="list-style-type: none"> produced a well ordered and relevant range of appropriate research information; thoroughly analysed the task and research material; produced a detailed specification closely reflecting the analysis; produced a wide range of proposals which satisfy the specification; used their proposals and relevant knowledge of techniques, manufacturing and working characteristics of materials to develop a detailed design solution; planned the correct sequence of making activities; tested, evaluated and modified their work throughout the process as appropriate; used an appropriate range of communication, graphical and ICT skills sufficient to convey ideas to themselves and others effectively; provided evidence of having considered relevant issues, industrial practices and systems and control. 	<ol style="list-style-type: none"> recorded and justified the need for any changes or adaptations; used appropriate materials, components, tools, equipment and processes (including CAM) skilfully, correctly and safely; made a complete, effective and skilfully-produced outcome; demonstrated a level of accuracy and finish in the product which satisfies the demands of the design solution; provided evidence of QA & QC throughout manufacture.
A	<ol style="list-style-type: none"> used a wide variety of appropriate sources to gather relevant research information; analysed the task and the research material logically, thoroughly and effectively; produced a detailed specification which focuses closely on the analysis; produced a wide range of distinct proposals which satisfy the specification; used one or more of their proposals and relevant knowledge of techniques, manufacturing and working characteristics to develop a detailed and coherent design solution; produced a correct sequence of activities which shows where, why and how practical production decisions were made; tested, objectively evaluated and effectively modified their work throughout the process as appropriate; selected and skilfully used a wide range of communication, graphical and ICT skills which have helped to clarify their thinking and are sufficient to convey ideas to themselves and others effectively and precisely; provided evidence that they have considered and taken account of relevant issues, industrial practices and systems and control. 	<ol style="list-style-type: none"> recorded and justified the need for any changes or adaptations; used appropriate materials, components, equipment and processes (including CAM) consistently correctly, skilfully and safely; made a complete product of high quality; demonstrated an ability to satisfy accurately and completely all the demands of the design solution; thoroughly considered QA & QC and applied them consistently and successfully.

16.4 Quality of Written Communication

An assessment for the quality of written communication shown in the completed design folder is to be made separately from the designing grade. Use the criteria given below and record the mark on the Candidate Record Form.

Marks

- 4-5 Information is clearly and logically presented using an appropriate form. The text is legible. Candidates spell, punctuate and use the rules of grammar accurately, enabling the meaning to be clearly understood.
- 2-3 Information is presented in an appropriate form. The text is legible. Candidates generally spell, punctuate and use the rules of grammar accurately, although there may be some errors. The meaning is clear.
- 1 Some of the information presented is in an appropriate form. Generally the text is legible. Although there are errors in spelling, punctuation and grammar, candidates' meaning can be understood.
- 0 Candidates have failed to reach the standard required for the award of a mark.

16.5 Evidence to Support the Award of Marks

Teachers should keep records of their assessments during the course, in a form which facilitates the complete and accurate submission of the final assessments at the end of the course.

When the assessments are complete, the grades and/or marks awarded under each of the assessment criteria must be entered on the Candidate Record Form, with supporting information given in the spaces provided. A specimen Candidate Record Form appears in Appendix B; the exact design may be modified before the operational version is issued and the correct year's Candidate Record Forms should always be used.

Supervision and Authentication

-
- 17.1 Supervision of Candidates' Work** Candidates' work for assessment must be undertaken under conditions which allow the teacher to supervise the work and enable the work to be authenticated. If it is necessary for some assessed work to be done outside the centre, sufficient work must take place under direct supervision to allow the teacher to authenticate each candidate's whole work with confidence.
-
- 17.2 Guidance by the Teacher** The work assessed must be solely that of the candidate concerned.
- The Coursework Project is, however, as much a vehicle for teaching as for assessment. It is therefore expected that the teacher will need to give advice and assistance to individual candidates as part of normal teaching. This should be provided, but normally in such a way that candidates have alternative possibilities to explore, and their own decisions to make about accepting or using the information or advice provided by the teacher. There may, of course, be occasions when direct teacher intervention is necessary to ensure safety, to prevent costly waste of materials or to provide a less able candidate with positive assistance.
- In any case where assistance given to an individual candidate goes beyond normal teaching, details must be recorded on the Candidate Record Form and taken into account in the assessment of coursework.
-
- 17.3 Unfair Practice** At the start of the course, the supervising teacher is responsible for informing candidates of the AQA Regulations concerning malpractice. Candidates must not take part in any unfair practice in the preparation of coursework to be submitted for assessment, and must understand that to present material copied directly from books or other sources without acknowledgement will be regarded as deliberate deception. Centres must report suspected malpractice to AQA. The penalties for malpractice are set out in the AQA Regulations.
-
- 17.4 Authentication of Candidates' Work** Both the candidate and the teacher are required to sign declarations confirming that the work submitted for assessment is the candidate's own. The teacher declares that the work was conducted under the specified conditions, and records details of any additional assistance.

18

Standardisation

18.1 Standardising Meetings

Annual standardising meetings will usually be held in the autumn term. Centres entering candidates for the first time must send a representative to the meetings. Attendance is also mandatory in the following cases:

- where there has been a serious misinterpretation of the specification requirements;
- where the nature of coursework tasks set by a centre has been inappropriate;
- where a significant adjustment has been made to a centre's marks in the previous year's examination.

After the first year, attendance is at the discretion of centres. At these meetings support will be provided for centres in the development of appropriate coursework tasks and assessment procedures.

18.2 Internal Standardisation of Marking

The centre is required to standardise the assessments across different teachers and teaching groups to ensure that all candidates at the centre have been judged against the same standards. If two or more teachers are involved in marking a component, one teacher must be designated as responsible for internal standardisation. Common pieces of work must be marked on a trial basis and differences between assessments discussed at a training session in which all teachers involved must participate. The teacher responsible for standardising the marking must ensure that the training includes the use of reference and archive materials such as work from a previous year or examples provided by AQA. The centre is required to send to the moderator the Centre Declaration Sheet, duly signed, to confirm that the marking of centre-assessed work at the centre has been standardised. If only one teacher has undertaken the marking, that person must sign this form.

A specimen Centre Declaration Sheet appears in Appendix B.

Administrative Procedures

19.1 Recording Assessments

The candidates' work must be marked according to the assessment criteria set out in sections 16.3 and 16.4. The marks and supporting information must be recorded in accordance with the instructions in Section 16.5. The completed Candidate Record Form for each candidate must be attached to the work and made available to AQA on request.

At the beginning of the course, centres are required to inform the AQA of the approximate number of candidates to be entered for the examination so that the appropriate number of Candidate Record Forms may be sent.

19.2 Submitting Marks and Sample Work for Moderation

The total component mark for each candidate must be submitted to AQA on the mark sheets provided or by Electronic Data Interchange (EDI) by the specified date. Centres will be informed which candidates' work is required in the samples to be submitted to the moderator.

19.3 Factors Affecting Individual Candidates

Teachers should be able to accommodate the occasional absence of candidates by ensuring that the opportunity is given for them to make up missed assessments.

Special consideration should be requested for candidates whose work has been affected by illness or other exceptional circumstances. Information about the procedure is issued separately.

If work is lost, AQA should be notified immediately of the date of the loss, how it occurred, and who was responsible for the loss. AQA will advise on the procedures to be followed in such cases.

Where special help which goes beyond normal learning support is given, AQA must be informed so that such help can be taken into account when assessment and moderation take place.

Candidates who move from one centre to another during the course sometimes present a problem for a scheme of internal assessment. Possible courses of action depend on the stage at which the move takes place. If the move occurs early in the course the new centre should take responsibility for assessment. If it occurs late in the course it may be possible to accept the assessments made at the previous centre. Centres should contact AQA at the earliest possible stage for advice about appropriate arrangements in individual cases.

19.4 Retaining Evidence and Re-Using Marks

The centre must retain the work of all candidates, with Candidate Record Form attached, under secure conditions, from the time it is assessed, to allow for the possibility of an enquiry upon results. The work may be returned to candidates after the issue of results provided that no enquiry upon result is to be made which will include re-moderation of the coursework component. If an enquiry upon result is to be made, the work must remain under secure conditions until requested by AQA.

Candidates repeating the examination may carry forward their moderated mark for the coursework component once only and within a twelve month period.

Moderation

20.1 Moderation Procedures

Moderation of the coursework is by inspection of a sample of candidates' work. This will initially involve design folders for the sample being sent by post from the centre to the moderator appointed by AQA. Moderators will visit new centres to assess the practical outcomes. They will also visit other centres as needs dictate. The centre marks must be submitted to AQA and the sample of design folders must reach the moderator by the specified date in the year in which the qualification is awarded.

Following the re-marking of the sample work, the moderator's marks are compared with the centre marks to determine whether any adjustment is needed in order to bring the centre's assessments into line with standards generally. In some cases it may be necessary for the moderator to call for the work of other candidates. In order to meet this possible request, centres must have available the coursework and Candidate Record Form of every candidate entered for the examination and be prepared to submit it on demand. Mark adjustments will normally preserve the centre's order of merit, but where major discrepancies are found, AQA reserves the right to alter the order of merit.

20.2 Post-Moderation Procedures

On publication of the GCSE results, the centre is supplied with details of the final marks for the coursework component.

The candidates' work is returned to the centre after the examination with a report form from the moderator giving feedback to the centre on the appropriateness of the tasks set, the accuracy of the assessments made, and the reasons for any adjustments to the marks.

Some candidates' work may be retained by AQA for archive purposes.

Awarding and Reporting

21

Grading, Shelf-Life and Re-Sits

- | | |
|--|---|
| <p>21.1 Qualification Titles</p> | <p>The qualification based on this specification has the following title:</p> <p>AQA General Certificate of Secondary Education in Design and Technology (Systems and Control Technology).</p> |
| <p>21.2 Grading System</p> | <p>The qualification will be graded on an 8 point grade Scale A*, A, B, C, D, E, F, G. Candidates who fail to reach the minimum standard for grade G will be recorded as U (unclassified) and will not receive a qualification certificate.</p> <p>Candidates must be entered for either the Foundation Tier or Higher Tier. For candidates entered for the Foundation Tier, grades C–G are available. For candidates entered for the Higher Tier A*–D are available. There is a safety net for candidates entered for the Higher Tier, where an allowed Grade E will be awarded where candidates just fail to achieve Grade D. Candidates who fail to achieve a Grade E on the Higher Tier or Grade G on the Foundation Tier will be reported as unclassified.</p> |
| <p>21.3 Re-Sits</p> | <p>Individual components may not be retaken, but candidates may retake the whole qualification more than once.</p> |
| <p>21.4 Minimum Requirements</p> | <p>Candidates will be graded on the basis of work submitted for assessment.</p> |
| <p>21.5 Carrying Forward of Centre-Assessed Marks</p> | <p>Candidates re-taking the examination may carry forward their moderated coursework marks. These marks have a shelf-life which is limited only by the shelf-life of the specification, and they may be carried forward an unlimited number of times within this shelf-life.</p> |
| <p>21.6 Awarding and Reporting</p> | <p>The regulatory authorities, in consultation with GCSE awarding bodies, developed a revised Code of Practice for GCSE qualifications which were introduced in September 2000. This specification complies with the grading, awarding and certification requirements of the current GCSE, GCSE in vocational subjects, GCE, VCE, GNVQ and AEA Code of Practice 2004/5 and will be revised in the light of any subsequent changes for future years.</p> |

Appendices

A

Grade Descriptions

The following grade descriptors indicate the level of attainment characteristic of the given grade at GCSE. They give a general indication of the required learning outcomes at each specific grade. The descriptors should be interpreted in relation to the content outlined in the specification; they are not designed to define that content.

The grade awarded will depend in practice upon the extent to which the candidate has met the assessment objectives (as in section 6) overall. Shortcomings in some aspects of the examination may be balanced by better performances in others.

Grade F When designing and making products, and acquiring and applying knowledge, skills and understanding, candidates draw on and use various sources of information. They clarify their ideas through discussion, drawing and modelling; use their understanding of the characteristics of familiar products when developing and communicating their own ideas and work from their own plans, modifying them where appropriate.

Candidates work with a range of tools, materials, equipment, components and processes with some precision; check their work as it develops and modify their approach in the light of progress; test and evaluate their products, showing that they understand the situations in which their designs will have to function and are aware of resources as a constraint and evaluate their use of basic information sources.

Grade C When designing and making products, and acquiring and applying knowledge, skills and understanding, candidates use a wide range of appropriate sources of information and strategies to develop ideas, responding to information they have identified. They investigate form, function and production processes and communicate ideas, using appropriate media.

Candidates recognise the needs of users and develop realistic designs. They produce plans that make use of time and resources to carry out the main stages of making products. They work with a range of tools, materials, equipment, components and processes, taking account of their characteristics, and organise their work so that they can carry out processes accurately and consistently, and use tools, equipment, materials and components with precision.

Candidates adapt their methods of manufacture to changing circumstances, providing a sound explanation for any change from the initial specification. They select appropriate techniques to test and

evaluate how their products would perform when used and modify their products in the light of ongoing evaluation to improve their performance. They evaluate their use of information sources.

Grade A When designing and making products, and acquiring and applying knowledge, skills and understanding, candidates seek out and use information to help their detailed design thinking, and recognise the needs of a variety of client groups. They are discriminating in their selection and use of information sources to support their work and they use a wide range of strategies to develop appropriate ideas, responding to information they have identified.

Candidates investigate form, function and production processes and communicate ideas using a variety of appropriate media. They recognise the different needs of a range of users when developing fully realistic designs. When planning, they make sound decisions on materials and techniques based on their understanding of the physical properties and working characteristics of materials. They work from formal plans that make the best use of time and resources; work with a range of tools, equipment, materials and components to a high degree of precision and make products that are reliable and robust and that fully meet the quality requirements given in the design proposal.

Candidates identify conflicting demands on their design, explain how their ideas address these demands and use this analysis to produce proposals. They identify a broad range of criteria for evaluating and testing their products, clearly relating their findings to the purpose for which the products were designed and the appropriate use of resources, and fully evaluate their use of information sources.

B

Record Forms



Centre-assessed work Centre Declaration Sheet 2008

Specification Title: Unit Code:

Centre Name: Centre No:

--	--	--	--	--

Authentication

This is to certify that marks have been awarded in accordance with the requirements of the specification and that every reasonable step has been taken to ensure that the work presented is that of the candidates named. Any assistance given to candidates beyond that given to the class as a whole and beyond that described in the specification has been recorded on the Candidate Record Form(s) and has been taken into account. The marks given reflect accurately the unaided achievement of the candidates.

Signature(s) of teacher(s) responsible for assessment

Teacher 1 Teacher 2

Teacher 3 Teacher 4

Teacher 5 Teacher 6

(Continue overleaf if necessary)

Internal Standardisation of Marking

Each centre must standardise the assessments for this unit across different teachers and teaching groups to ensure that all candidates in the centre have been judged against the same standards. If two or more teachers are involved in marking a unit, one of them must be designated as responsible for standardising the marking of all teachers at the centre who mark the unit.

The following declaration must be signed by the teacher responsible for ensuring standardisation. If all the work has been marked by the same person, that person should sign below.

I confirm that:

- (a) *I have marked the work of all candidates for this component;
- (b) *the procedure described in the specification has been followed at this centre to ensure that the marking is of the same standard for all candidates.

(*Delete as applicable)

Signed: Date:

Signature of Head of Centre Date:

This form should be completed and sent to the moderator with the sample of centre-assessed work.



Centre-assessed work Candidate Record Form 2008

GCSE D&T: Systems and Control Technology 3546

Centre name: Centre no:

--	--	--	--	--

Candidate name: Candidate no:

--	--	--	--

This side is to be completed by the candidate

Sources of advice and information

1. Have you received any help or information from anyone other than your subject teacher(s) in the production of this work? (Write YES or NO)
2. If you have answered YES, give details below. Continue on a separate sheet if necessary.
.....
3. If you have used any books, information leaflets or other materials (e.g. videos, software packages or information from the Internet) to help you complete this work, you must list these below, unless they are clearly acknowledged in the work itself. To present material copied from books or other sources without acknowledgement will be regarded as deliberate deception.
.....
.....

NOTICE TO CANDIDATE

The work you submit for assessment must be your own.

If you copy from someone else or allow another candidate to copy from you, or if you cheat in any other way, you may be disqualified from at least the subject concerned.

Declaration by candidate

I have read and understood the Notice to Candidate (above). I have produced the attached work without any help apart from that which I have stated on this sheet.

As part of AQA's commitment to assist students, AQA may make your coursework available on a strictly anonymous basis to teachers, examining staff and students in paper form or electronically, through the Internet or other means, for the purpose of indicating a typical mark or for other educational purposes. In the unlikely event that your coursework is made available for the purposes stated above, you may object to this at any time and we will remove the work on reasonable notice. If you have any concerns, please contact crf@aqa.org.uk

Candidate's signature: Date:

This form should be completed and attached to the candidate's work and retained at the Centre or sent to the moderator as required.

PTO

Designing skills	<i>Comments should be added where they will help with the interpretation of work</i>	Grade
Research		
Analysis (of problem/task and research)		
Specification		
Generation of ideas		
Development of solution		
Planning of making		
Evaluation, testing and modification		
Use of communication, graphical and use of ICT skills		
Social issues, industrial practices and systems and control (including the use of CAD)		
Final Designing grade		

Making skills	<i>Comments should be added where they will help with the interpretation of work</i>	Grade
Correction of working errors (where needed) including modifications		
Use of appropriate equipment and processes (including the use of CAM)		
Production and effectiveness of outcome		
Level of accuracy and finish		
Use of Quality Assurance (QA) and Quality Control (QC)		
Final Making grade		

This side is to be completed by the teacher

The grades and marks for the project must be awarded in accordance with the instructions and criteria in section 16 of the specification.

Please complete the table below.

1	Designing grade	
2	Making grade	
3	Matrix mark (max 90)	
4	QWC mark (max 5)	
5	Total mark (3+4)	

Supporting information to show how the final assessment has been arrived at should be given briefly in the form of annotation on pages 2 and 3 and additional information given in the space below where necessary.

Additional assistance given (if any)

Record below details of any assistance given to this candidate which is beyond that given to the class as a whole and beyond that described in the specification.

Teacher's signature: Date:

C

Overlaps with other Qualifications

Some overlaps exist between this and other Design and Technology specifications. The overlap is primarily in the design process and the scheme of assessment. As all specifications conform to the GCSE Design and Technology Subject Criteria, there are also overlaps of broad content, e.g. ICT, health and safety, systems and control, industrial and commercial practice, and for Systems and Control Technology, some overlap with Electronic Products.

D

Project Assessment Matrix

DESIGN & TECHNOLOGY PROJECT ASSESSMENT MATRIX

DESIGNING SKILLS

	A			B			C			D			E			F			G			U								
	H	M	L	H	M	L	H	M	L	H	M	L	H	M	L	H	M	L	H	M	L	H	M	L						
A	90	89	88	86	85	84	82	81	80	78	77	76	74	73	72	70	69	68	66	65	64	62	61	60	58	57	56	54	53	52
B	88	87	86	84	83	82	80	79	78	76	75	74	72	71	70	68	67	66	64	63	62	60	59	58	56	55	54	52	51	50
C	86	85	84	82	81	80	78	77	76	74	73	72	70	69	68	66	65	64	62	61	60	58	57	56	54	53	52	50	49	48
D	82	81	80	78	77	76	74	73	72	70	69	68	66	65	64	62	61	60	58	57	56	54	53	52	50	49	48	46	45	44
E	74	73	72	70	69	68	66	65	64	62	61	60	58	57	56	54	53	52	50	49	48	46	45	44	42	41	40	38	37	36
F	72	71	70	68	67	66	64	63	62	60	59	58	56	55	54	52	51	50	48	47	46	44	43	42	40	39	38	36	35	34
G	70	69	68	66	65	64	62	61	60	58	57	56	54	53	52	50	49	48	46	45	44	42	41	40	38	37	36	34	33	32
U	66	65	64	62	61	60	58	57	56	54	53	52	50	49	48	46	45	44	42	41	40	38	37	36	34	33	32	30	29	28
M	64	63	62	60	59	58	56	55	54	52	51	50	48	47	46	44	43	42	40	39	38	36	35	34	32	31	30	28	27	26
A	62	61	60	58	57	56	54	53	52	50	49	48	46	45	44	42	41	40	38	37	36	34	33	32	30	29	28	26	25	24
K	58	57	56	54	53	52	50	49	48	46	45	44	42	41	40	38	37	36	34	33	32	30	29	28	26	25	24	22	21	20
I	56	55	54	52	51	50	48	47	46	44	43	42	40	39	38	36	35	34	32	31	30	28	27	26	24	23	22	20	19	18
N	54	53	52	50	49	48	46	45	44	42	41	40	38	37	36	34	33	32	30	29	28	26	25	24	22	21	20	18	17	16
G	50	49	48	46	45	44	42	41	40	38	37	36	34	33	32	30	29	28	26	25	24	22	21	20	18	17	16	14	13	12
S	48	47	46	44	43	42	40	39	38	36	35	34	32	31	30	28	27	26	24	23	22	20	19	18	16	15	14	12	11	10
L	46	45	44	42	41	40	38	37	36	34	33	32	30	29	28	26	25	24	22	21	20	18	17	16	14	13	12	10	9	8
L	42	41	40	38	37	36	34	33	32	30	29	28	26	25	24	22	21	20	18	17	16	14	13	12	10	9	8	6	5	4
S	40	39	38	36	35	34	32	31	30	28	27	26	24	23	22	20	19	18	16	15	14	12	11	10	8	7	6	4	3	2
L	38	37	36	34	33	32	30	29	28	26	25	24	22	21	20	18	17	16	14	13	12	10	9	8	6	5	4	2	1	0

M A K I N G S K I L L S