

Surname		Other Names	
Centre Number		Candidate Number	
Candidate Signature			

Leave blank

General Certificate of Secondary Education
June 2004

**DESIGN AND TECHNOLOGY
(ELECTRONIC PRODUCTS) (SHORT COURSE)
Foundation Tier**

3551/F

F



Friday 28 May 2004 1.30 pm to 3.00 pm

In addition to this paper you will require:
blue or black pen, pencil, coloured pencils and ruler.
You may use a calculator.

For Examiner's Use	
Number	Mark
1	
2	
3	
4	
5	
6	
TOTAL	
Examiner's initials	

Time allowed: 1 hour 30 minutes

Instructions

- Use blue or black ink or ball-point pen.
- Fill in the boxes at the top of this page.
- Answer **all** questions in the spaces provided.
- Do all rough work in this book. Cross through any work you do not want marked.

Information

- The maximum mark for this paper is 100.
- Mark allocations are shown in brackets.
- A list of formulae and other information is given on pages 2 and 3 which you may need to use when answering certain questions.
- Wherever calculations are needed you should show your working.
- You are reminded of the need for good English and clear presentation.

You may need to use one or more of the following formulae when answering questions which include calculations.

Potential Difference Potential Difference = Current \times Resistance ($V = I \times R$)

Series Resistors $R_{\text{total}} = R_1 + R_2 + R_3$ etc

Electrical Power Electrical Power = Current \times Potential Difference ($P = I \times V$)

Potential Divider

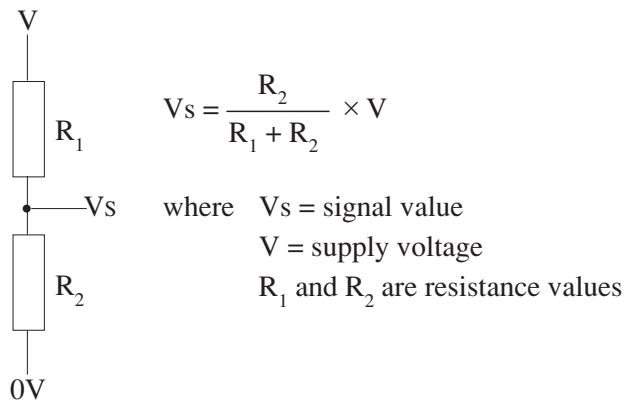

Time Constant Time Constant \approx Resistance \times Capacitance ($T \approx R \times C$)

Astable
Frequency for 555 $f = \frac{1.44}{(R_1 + 2R_2) \times C}$

Pulse duration $= \frac{1}{\text{frequency}}$

You may need to use the following information when answering some of the questions.

Capacitor series 10, 22, 47

Resistor Colour Code

Colour	Band 1	Band 2	Band 3 (No. of 0s)	Band 4 (Tolerance)
Black	0	0	None	
Brown	1	1	0	
Red	2	2	00	
Orange	3	3	000	
Yellow	4	4	0000	
Green	5	5	00000	
Blue	6	6	000000	
Violet	7	7	–	
Grey	8	8	–	
White	9	9	–	
				Gold = 5%
				Silver = 10%

Turn over ►

Answer **all** questions in the spaces provided.

1 **Figure 1** shows a battery powered circuit that will turn on a child's night light.

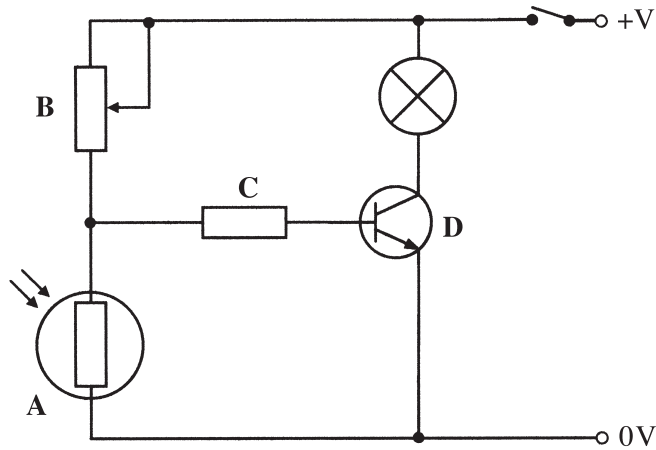

Figure 1

(a) Name the components labelled in **Figure 1**.

(i) **A** (1 mark)

(ii) **B** (1 mark)

(iii) **C** (1 mark)

(iv) **D** (1 mark)

(b) Complete **Figure 2** to show which of the components in **Figure 1** are in the following stages of the control system.

Input	Control/Process	Output
.....
.....	

Figure 2

(5 marks)

(c) Circle **one** of the following words which describes what happens to the resistance value of component **A** when it gets dark.

Rises **Falls**

(1 mark)

(d) Give **two** reasons for having component **A** in the circuit.

1

2

(2 marks)

(e) Complete **Figure 3** by naming each of the legs of the component.

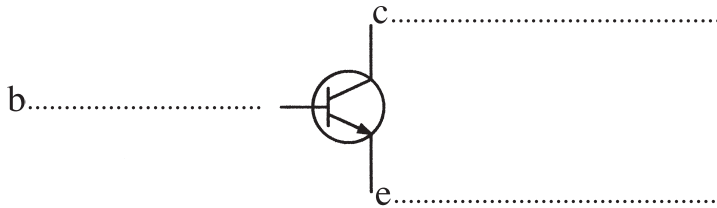

Figure 3

(3 marks)

(f) When the night light was tested, the battery only lasted for 5 nights.

Figure 4 shows a modified circuit that includes a relay with a d.c. mains power supply.

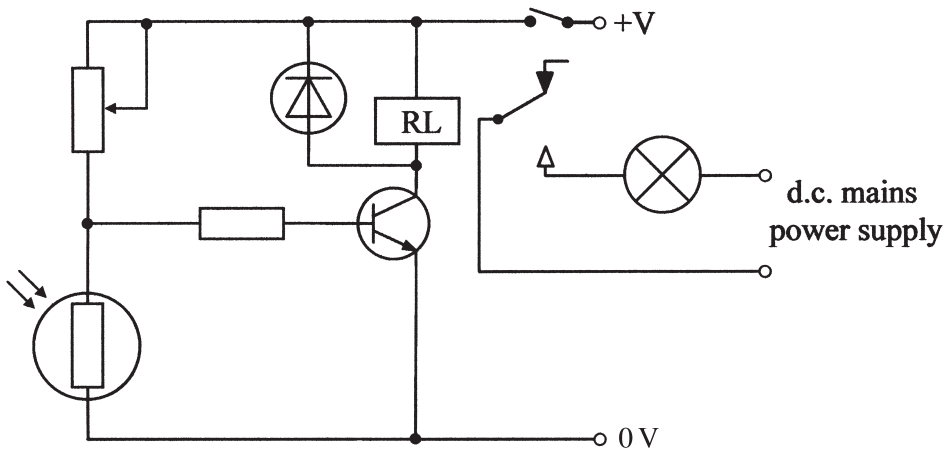

Figure 4

(i) Complete the name of the type of relay shown in **Figure 4**.

Single Pole

(2 marks)

(ii) Explain why the battery lasts longer in the circuit shown in **Figure 4**.

.....
.....
.....

(2 marks)

Turn over ►

2 **Figure 5** shows a circuit to be used as a timer.

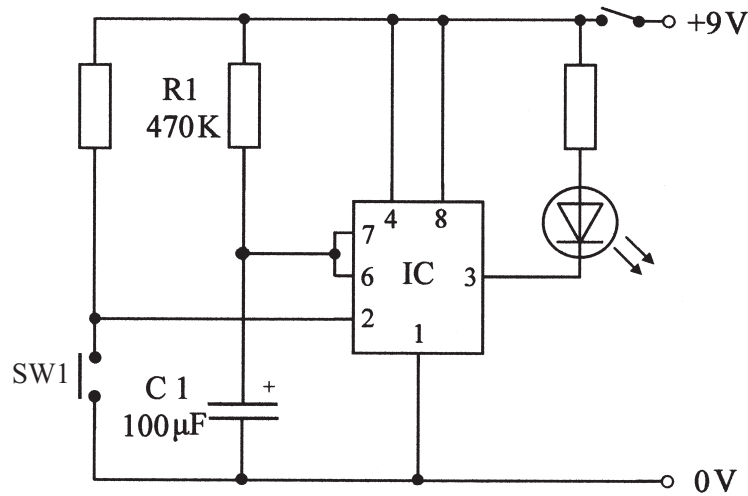

Figure 5

(a) Circle **one** of the following words which describes the circuit shown in **Figure 5**.

Astable

Monostable

(1 mark)

(b) Complete **Figure 6** to explain what feature of each component helps to make sure that it is connected into the circuit the right way round.

Component	Explanation
C1	The marking/stripe on the capacitor shows that the leg on that side goes to 0V. The other leg faces +V.
LED	
IC	

Figure 6

(4 marks)

(c) R1 helps to control the time delay of the circuit.

(i) Name the other component that controls the length of the time delay.

.....
(1 mark)

(ii) State the function of SW1.

.....
(1 mark)

(d) Calculate the time delay of the circuit shown in **Figure 5**.

Formula

Working

Answer and Units
(3 marks)

(e) The circuit did not work when tested.

Name a suitable testing device that measures voltage and resistance.

.....
(1 mark)

(f) State the readings and units that you would expect to find at the following places on the circuit when the circuit was working:

(i) the voltage between Pin 8 and 0 V when the circuit is switched on;

.....
(1 mark)

(ii) the resistance between Pin 7 and Pin 6.

.....
(1 mark)

3 This question is about designing a case for a timer circuit.

Figure 7 shows a *full size* drawing of the PCB and the components of the circuit.

(a) Sketch **two** different ideas for the casing of the timer.

Your ideas should show well drawn and labelled sketches that include suggestions of both the different materials and suitable construction methods that could be used.

(9 marks)

Quality of drawing (3 marks)

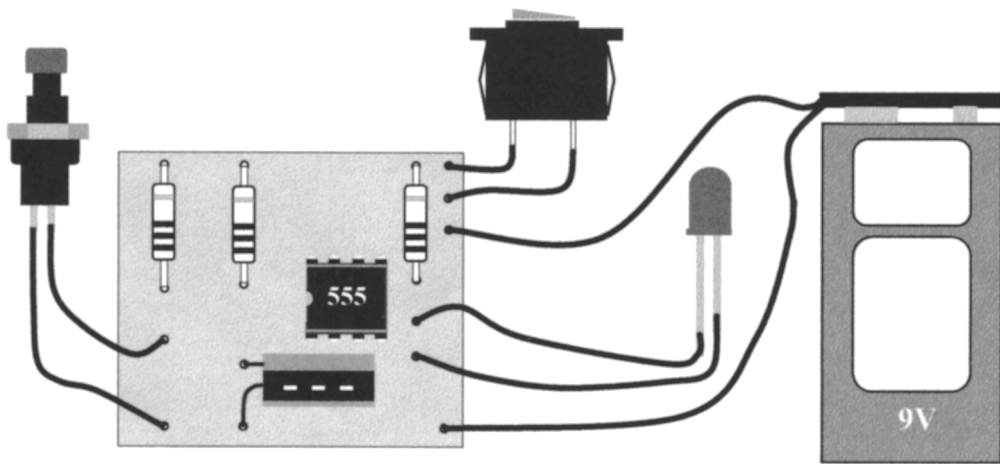

Figure 7

(b) Choose **one** of your ideas and show using notes and quality sketches the details of:

- the specific material used for the case; *(1 mark)*
- the method of construction for the material chosen; *(2 marks)*
- sizes/dimensions of the case; *(2 marks)*
- how the circuit and battery are made accessible; *(3 marks)*
- the positions of the two switches and the LED. *(3 marks)*

Quality of drawing *(3 marks)*

4 **Figure 8** shows a disco light box controlled by a PIC and the output commands for turning on the different lamps.

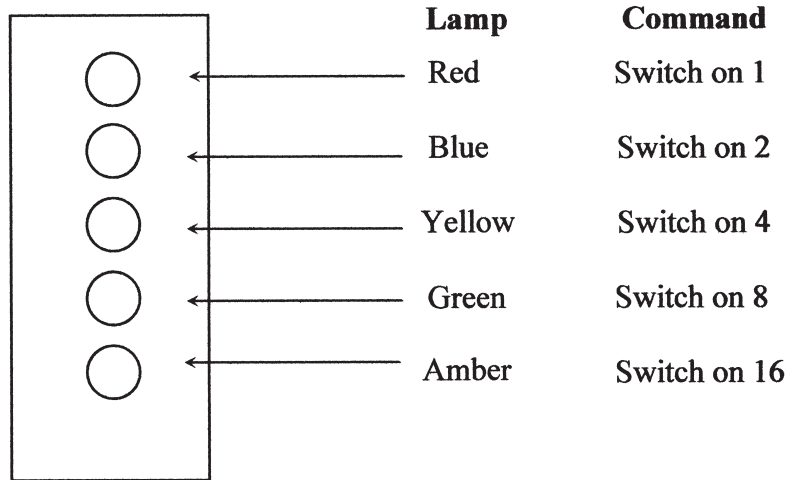

Figure 8

Figure 9 shows part of a flow chart and an incomplete program for controlling the lamps.

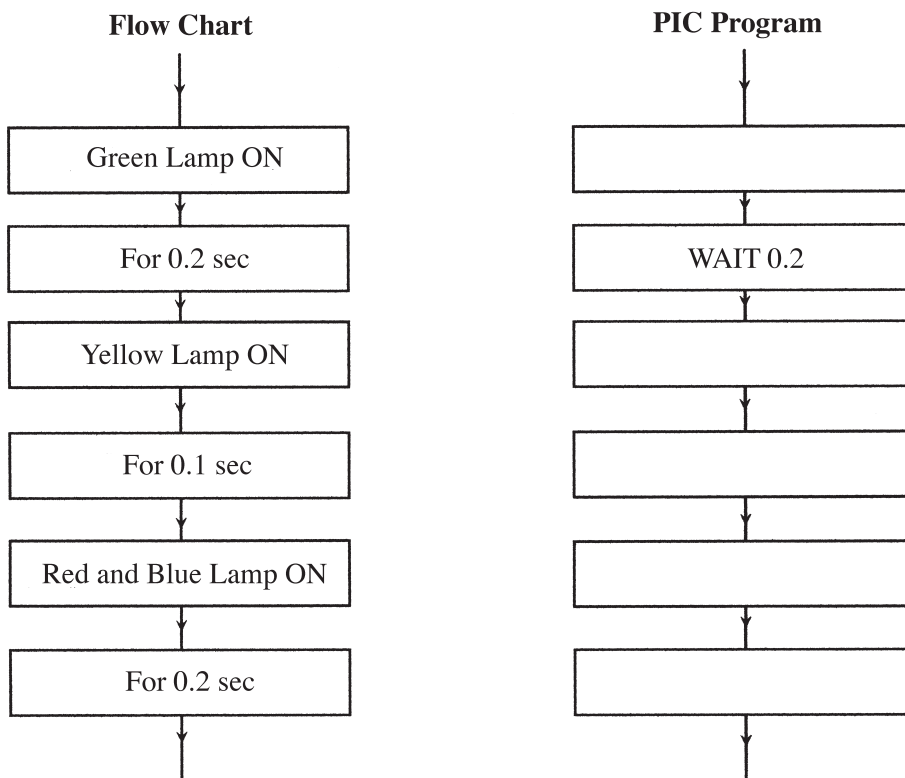

Figure 9

(a) Use the information given to complete the PIC program.

(5 marks)

(b) **Figure 10** shows the lamps connected to the outputs of the PIC microcontroller.

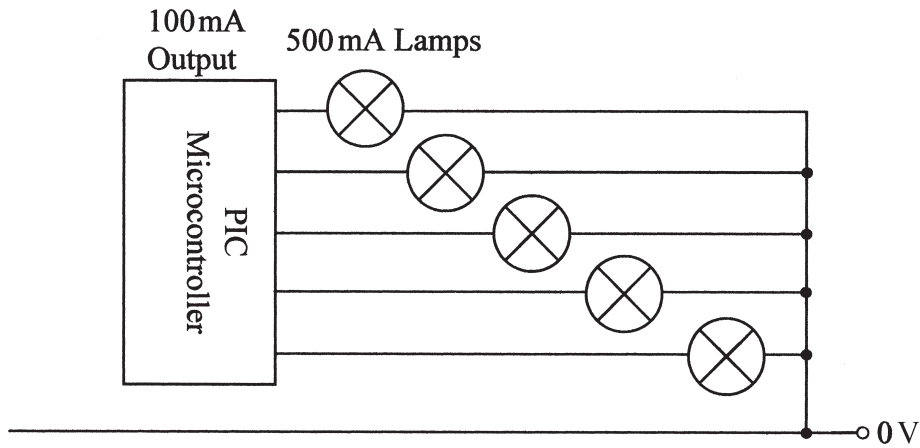

Figure 10

(i) Give the reason for the lamps not working when the circuit was switched on.

.....

(2 marks)

(ii) **Figure 11** shows an improved circuit.

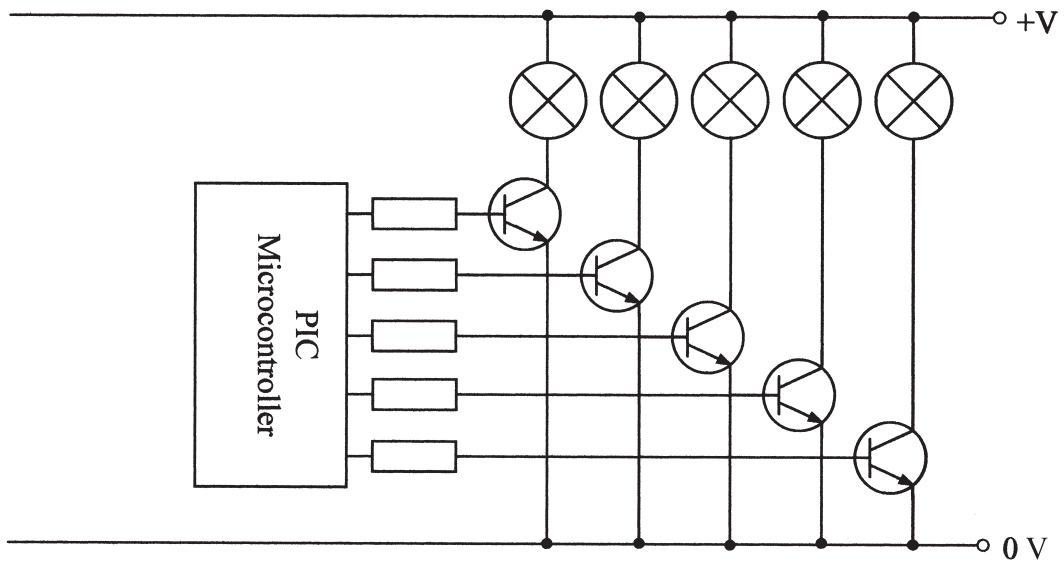

Figure 11

Explain why the circuit in **Figure 11** would be more successful.

.....

(2 marks)

Turn over ►

5 The PCB of a chosen circuit can be drawn using CAD.

(a) Give the meaning of the letters:

(i) PCB; (1 mark)

(ii) CAD. (1 mark)

(b) The PCB design shown in **Figure 12** is a student's first attempt.

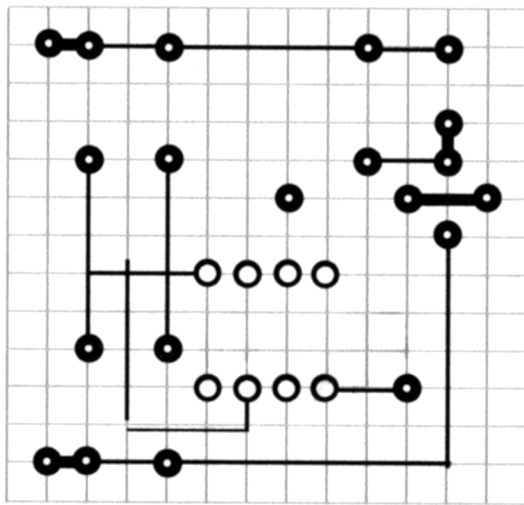

Figure 12

(i) Label **Figure 12** to show which part of the PCB design is:

- a track
- a pad.

(2 marks)

(ii) Give **three** changes that would need to be made to the student's first attempt in order to improve the quality of the PCB design.

1

2

3

(3 marks)

(c) Complete **Figure 13** by including the details of:

- one further stage that would take place between the first and final stages of the production of a circuit using veroboard or a PCB;
- the health and safety and quality issues when soldering.

	First stage of production
Activity	Mark out and cut the board to size
Tools and Equipment	PCB guillotine or bandsaw
Health and Safety	Fingers clear of cutter, goggles for bandsaw
Quality Issues	Accurate measuring and marking out



	Further stage of production
Activity	
Tools and Equipment	
Health and Safety	
Quality Issues	

(8 marks)



	Final stage of production
Activity	Solder components to board
Tools and Equipment	Soldering iron, stand, solder and components
Health and Safety	
Quality Issues	

(4 marks)

Figure 13

Turn over ►

6 **Figure 14** shows a symbol commonly found on the cases of electronic products and on their packaging.



Figure 14

(a) Give the meaning of the symbol.

.....
(1 mark)

(b) Electronic products are housed in cases and include components made from plastic and metal.

Give **one** problem for the environment caused by the use of these materials.

(i) Plastic

.....
(1 mark)

(ii) Metal

.....
(1 mark)

(c) One of the most popular everyday electronic products is the mobile phone.

Give **two** reasons for packaging mobile phones.

1

2

(2 marks)

(d) (i) Give **three** developments of the mobile phone that have provided advantages for the consumer.

- 1
- 2
- 3
(3 marks)

(ii) The development of the mobile phone has created disadvantages for consumers, society in general and the environment.

Give **one** of these disadvantages for:

1 consumers;
.....
(1 mark)

2 society;
.....
(1 mark)

3 the environment.
.....
(1 mark)

(e) Suggest **three** new developments which might become more commonly found on mobile phones in the next few years.

Your answers must include some comments to help explain whether your suggestions would have any positive or negative consequences.

- 1
-
- 2
-
- 3
-
(3 marks)

END OF QUESTIONS

THERE ARE NO QUESTIONS PRINTED ON THIS PAGE