

Centre Number						Candidate Number				
Surname										
Other Names										
Candidate Signature										

For Examiner's Use	
Examiner's Initials	
Question	Mark
1	
2	
3	
4	
5	
6	
7	
8	
TOTAL	



General Certificate of Secondary Education
June 2011

Design and Technology: 45401 Electronic Products

Unit 1 Written Paper

Wednesday 22 June 2011 9.00 am to 11.00 am

For this paper you must have:

- a pen, a pencil, a ruler, an eraser and a pencil sharpener.

Time allowed

- 2 hours

Instructions

- Use black ink or black ball-point pen.
- Fill in the boxes at the top of this page.
- Answer **all** questions.
- You must answer the questions in the spaces provided. Do not write outside the box around each page or on blank pages.
- Do all rough work in this book. Cross through any work you do not want to be marked.

Information

- The maximum mark for this paper is 120.
- The marks for questions are shown in brackets.
- You are reminded of the need for good English and clear presentation in your answers. Quality of Written Communication will be assessed in your answer to Question 8 (c).



J U N 1 1 4 5 4 0 1 0 1

You may need to use the following information when answering some of the questions.

The figures shown below and their decade multiples or submultiples are the series of preferred values in accordance with BS:2488.

E12 Resistor series 10, 12, 15, 18, 22, 27, 33, 39, 47, 56, 68, 82

E24 Resistor series 10, 11, 12, 13, 15, 16, 18, 20, 22, 24, 27, 30, 33, 36, 39, 43, 47, 51, 56, 62, 68, 75, 82, 91

Capacitor series 10, 22, 47

Resistor Colour Code

Colour	Band 1	Band 2	Band 3 (No. of 0s)	Band 4 (Tolerance)
Black	0	0	None	
Brown	1	1	0	
Red	2	2	00	
Orange	3	3	000	
Yellow	4	4	0000	
Green	5	5	00000	
Blue	6	6	000000	
Violet	7	7	–	
Grey	8	8	–	
White	9	9	–	
				Gold = 5%
				Silver = 10%

Turn over for the first question

Turn over ►



Section A

Answer **all** questions.

You should spend about 30 minutes on this question.

- 1 This question is about designing security for products which are displayed in shops.
- You have been asked to design a product security system.
- It is to be used with a point of sale display.



You are to design a system that meets the following specification.

- The system is suitable for use in a retail space.
- The system does not put the customer off.
- Products can still be handled by customers.
- The system can be used to protect one or more products.
- It will warn the retailer when products are removed.
- It is battery powered.
- The system can be switched on and off securely.



1 (a) Complete the table below to plan **two** different system ideas you might use.

SYSTEM IDEA	INPUT	PROCESS	OUTPUT
1			
2			

(6 marks)

1 (b) Select **one** of your system ideas from part (a) and explain why it is suitable.

My chosen system idea is number

.....

.....

.....

.....

.....

.....

.....

.....

.....

(3 marks)

Question 1 continues on the next page

Turn over ►



1 (c) Develop your design for the specification from page 4 in the space below.

(15 marks)



1 (d) Evaluate your design and explain how it meets the specification on page 4.

.....
.....
.....
.....
.....
.....
.....
.....

(4 marks)

1 (e) Describe the advantages and disadvantages of using batteries in a point of sale security system.

Advantages

.....
.....
.....
.....
.....
.....

Disadvantages

.....
.....
.....
.....
.....
.....

(4 marks)

32

Turn over ►



Section B

Answer **all** questions.

You should spend about 10 minutes on this question.

2 This question is about transducers.

A typical input transducer used in many electronic sensing circuits is shown below.

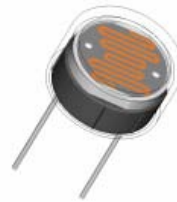
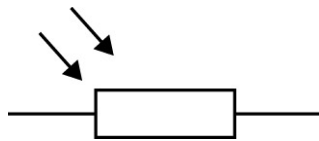

2 (a) (i) Name the transducer shown above.

.....
(1 mark)

2 (a) (ii) Give a use for the transducer.

.....
.....
(1 mark)



2 (a) (iii) Explain how the resistance changes in value with light levels from the diagram shown below.

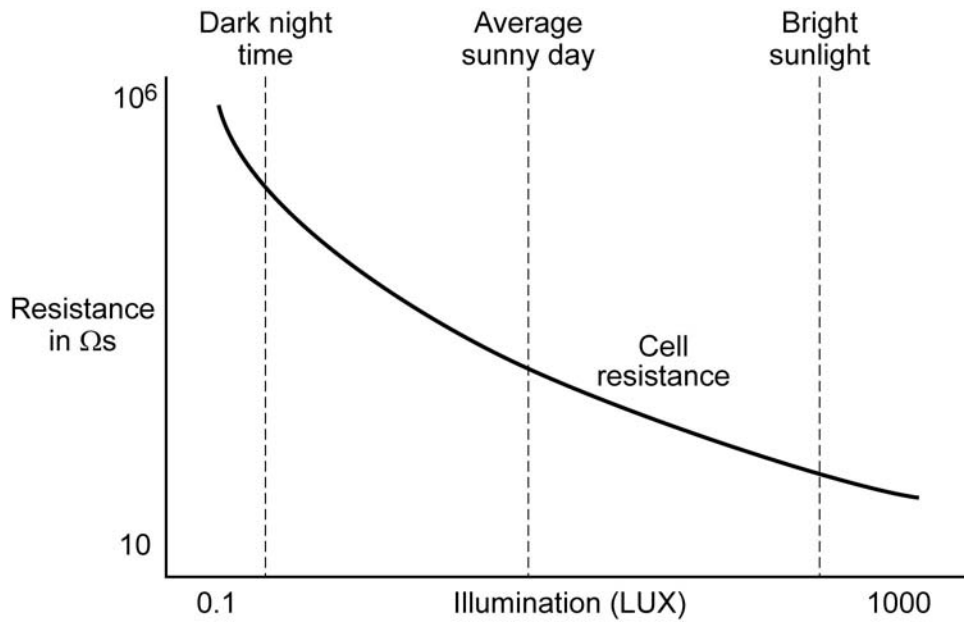

.....

.....

.....

.....

(2 marks)

Question 2 continues on the next page

Turn over ►



2 (b) (i) Describe the function of VR1 in the diagram shown below.

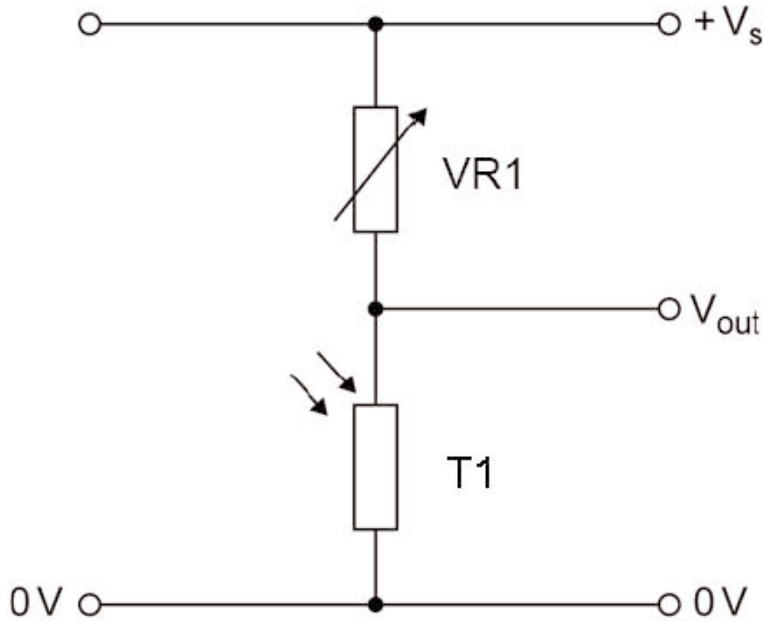

.....

.....

.....

.....

(2 marks)

2 (b) (ii) Explain why a phototransistor would be more suitable than the transducer labelled T1 shown in the diagram in part (b)(i).

.....

.....

.....

.....

(2 marks)



2 (c) (i) Name the component shown below.

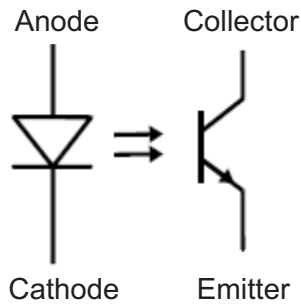

.....
(1 mark)

2 (c) (ii) Give a reason for using the above component in a circuit.

.....
.....
.....
.....
(2 marks)

Turn over for the next question

11

Turn over ►



You should spend about 15 minutes on this question.

3 This question is about counting.

Shown below is a 4017B Counter.

As part of a board game for four players with different colour LEDs, it is used to count up to four and then reset itself after the input push to make switch (PTM) has been pressed five times.

The output zero is not connected (NC).

3 (a) Draw in and label **all** the connections for

- the four LED outputs
- the reset pin
- the enable pin
- pull up resistor R1 and input PTM.

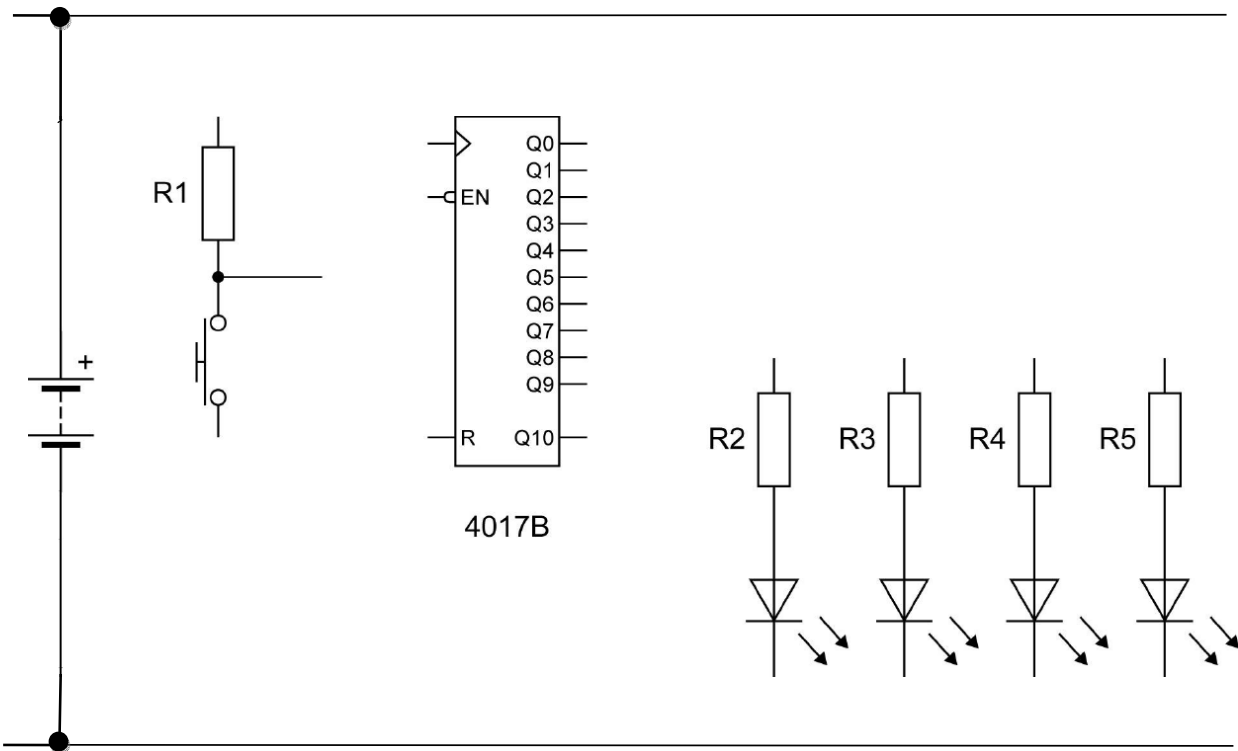

(12 marks)



3 (b) In use the circuit shown failed to count reliably.
This was probably caused by switch bounce.

3 (b) (i) Explain what is meant by switch bounce.

.....
.....

(1 mark)

3 (b) (ii) Describe a method for eliminating switch bounce.

.....
.....
.....
.....

(2 marks)

Turn over for the next question

15

Turn over ►



You should spend about 10 minutes on this question.

4 This question is about a thyristor (silicon controlled rectifier).

4 (a) (i) In the diagram shown below, circle the thyristor in the circuit.

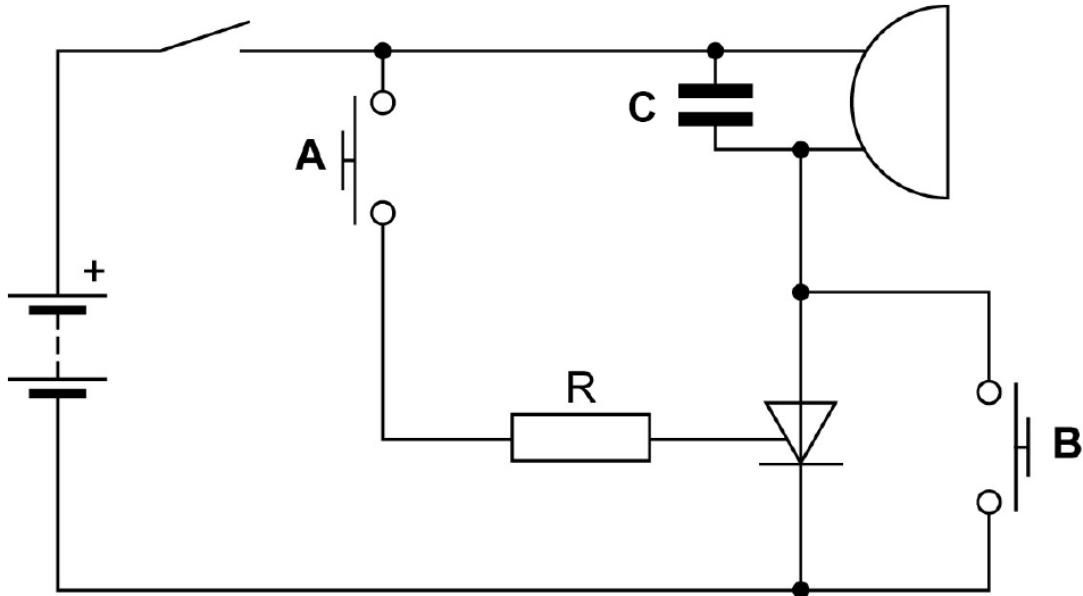

(1 mark)

4 (a) (ii) State the purpose of the thyristor in the circuit above.

.....

(1 mark)

4 (b) The circuit would not operate correctly until the capacitor C was replaced with a resistor.

Explain the purpose of that resistor.

.....

(2 marks)



4 (c) Describe what happens in the circuit when the push to make (PTM) switch **A** is pressed and released.

.....
.....
.....
.....

(2 marks)

4 (d) Explain the purpose of the push to make (PTM) switch **B**.

.....
.....
.....
.....

(2 marks)

4 (e) What is the function of the resistor labelled **R** in this circuit?

.....
.....
.....
.....

(2 marks)

Turn over for the next question

10

Turn over ►



You should spend about 20 minutes on this question.

5 This question is about microcontrollers.

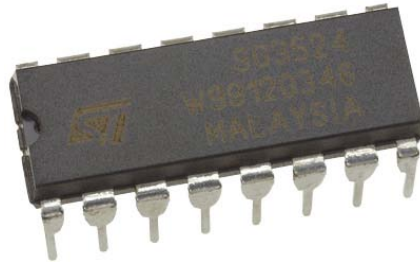

5 (a) Name **three** domestic products that contain a microcontroller.

1

2

3

(3 marks)

5 (b) State **two** reasons why microcontrollers are increasingly used to replace other types of circuit.

Reason 1

Reason 2

(2 marks)

5 (c) Microcontrollers can be programmed using either a flowchart or BASIC.

Describe the advantages of using **one** of these methods. You should state which method you are referring to.

.....

.....

.....

.....

.....

.....

(3 marks)



5 (d) Develop a microcontroller programme for a game with a random output generator. The designed output of the board game uses three LEDs to represent the outputs A-B-C.

Explain how the random output for each separate LED is created when a push to make (PTM) switch is pressed and then released.

You may use a graphical **or** a text based method in the box below.

(10 marks)

18

Turn over ►



You should spend about 10 minutes on this question.

6 This question is about 555 Timer circuits.

A child's toy operates for 10 seconds after a button is pressed and then stops.

6 (a) Explain why the circuit might be designed to switch off after 10 seconds.

.....

 (1 mark)

6 (b) Explain how this time delay could be changed.

.....

 (2 marks)

6 (c) For the circuit shown below calculate the value of R1 for a 10 second delay if the value of C is 1000 μ F. Your answer, together with the formula, calculation and units used should be given on the opposite page.

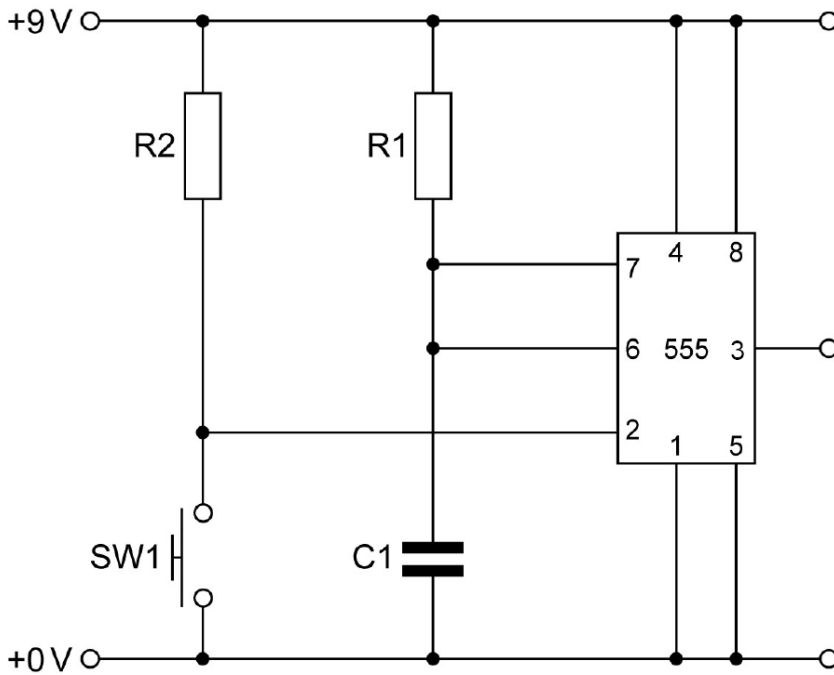

6 (c) (i) State the formula used

.....
.....

(1 mark)

6 (c) (ii) Show the calculation and the units used

.....
.....

(2 marks)

6 (c) (iii) Value of R1

(1 mark)

6 (c) (iv) Suggest a suitable value for resistor R2.

.....

(1 mark)

6 (c) (v) Explain the function of the resistor R2.

.....
.....
.....
.....

(2 marks)

Turn over for the next question

10

Turn over ►



You should spend about 10 minutes on this question.

7 This question is about Logic and Analogue signals.

7 (a) (i) Name the logic gate below.

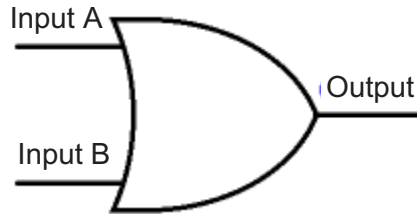

.....
(1 mark)

7 (a) (ii) Complete the truth table for the two input logic gate above.

B	A	OUTPUT
0	0	
0	1	
1	0	1
1	1	

(3 marks)



7 (b) Using the axes provided, draw and label a diagram that highlights the differences between analogue and digital signals.

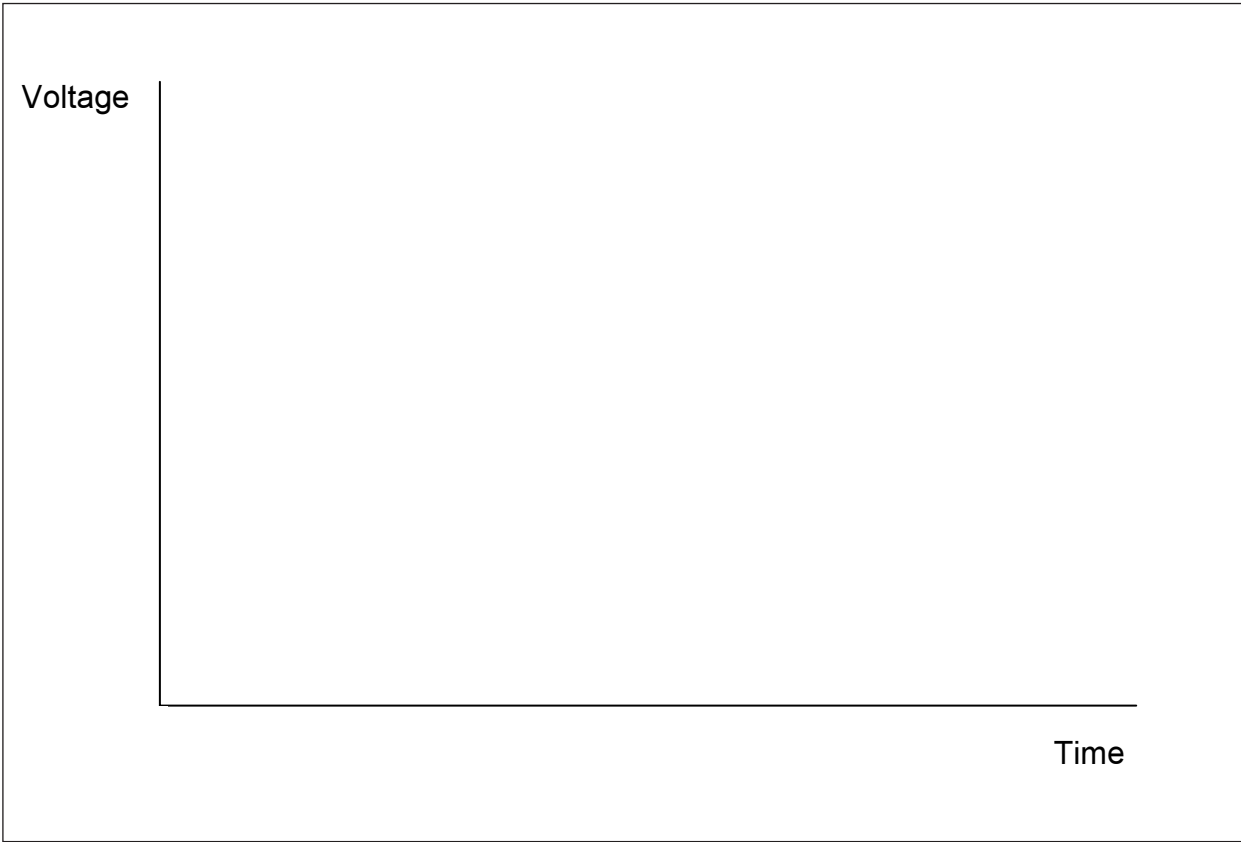

(4 marks)

8

Turn over for the next question

Turn over ►



You should spend about 15 minutes on this question.

8 This question is about manufacturing a product.

You have been asked to consider the design of a simple wired remote control handset for a toy with two push to make (PTM) inputs.



8 (a) State **three** important factors to consider in the design of this product.

1

.....

.....

.....

.....

2

.....

.....

.....

.....

3

.....

.....

.....

(6 marks)



There are no questions printed on this page

**DO NOT WRITE ON THIS PAGE
ANSWER IN THE SPACES PROVIDED**

ACKNOWLEDGEMENT OF COPYRIGHT-HOLDERS AND PUBLISHERS

Permission to reproduce all copyright material has been applied for. In some cases, efforts to contact copyright-holders have been unsuccessful and AQA will be happy to rectify any omissions of acknowledgements in future papers if notified.

Copyright © 2011 AQA and its licensors. All rights reserved.

