



General Certificate of Secondary Education
2010

Construction Single Award

Unit 2: Construction Technology

[GSK21]

MONDAY 17 MAY, AFTERNOON

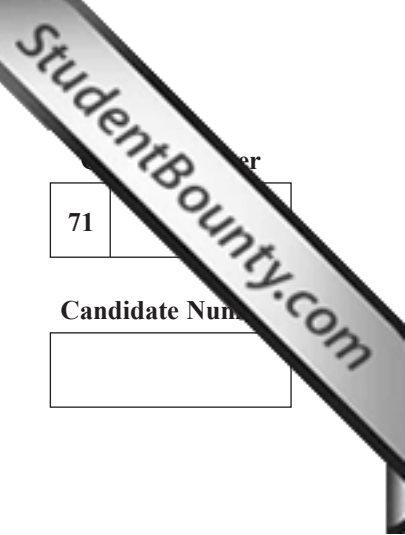

71	er
Candidate Number	
<input type="text"/>	

TIME

1 hour.

INSTRUCTIONS TO CANDIDATES

Write your Centre Number and Candidate Number in the spaces provided at the top of this page.

Write your answers in the spaces provided in this question paper.

Answer **all eight** questions.

Questions **1, 2, 3, 4, 5** and **7** should be answered in relation to the enclosed house plans and specifications previously issued as Pre-release materials.

You should not bring any of the material previously issued into this examination.

INFORMATION FOR CANDIDATES

The total mark for this paper is 100.

Figures in brackets printed down the right-hand side of pages indicate the marks awarded to each question or part question.

A scale ruler is required.

For Examiner's use only	
Question Number	Marks
1	
2	
3	
4	
5	
6	
7	
8	
Total Marks	

Section A

Examiner Only	
Marks	Remark

1 (a) What is the name given to the type of roof construction used on the house shown in the attached house plans?
_____ [1]

(b) After studying the attached specification, list **four** materials used in the roof construction.

1. _____

2. _____

3. _____

4. _____ [4]

2 Using the attached house plans, give the following internal room dimensions in millimetres. Dimensions may need to be scaled.

(a) The length and width of the conference room.
Length _____ mm Width _____ mm [4]

(b) The length and width of bedroom 2.
Length _____ mm Width _____ mm [4]

(c) The overall length of the dwelling from the outside of the structure.
Length _____ mm [2]

(d) The width and height of the window shown at A on the attached house plans.
Width _____ mm Height _____ mm [4]

Examiner Only	
Marks	Remark

3 (a) What is the name given to the wall construction used in the external walls of the dwelling shown in the attached house plans?

_____ [1]

(b) What type of walls are used to subdivide the downstairs floor area?

_____ [1]

(c) List **six** of the main functions of walls.

1. _____

2. _____

3. _____

4. _____

5. _____

6. _____ [6]

(d) Identify the type of bonding used in the wall shown in **Fig. 1** below.

_____ [1]



Fig. 1

(e) Why is it important to bond brickwork?

 _____ [3]

4 (a) Clearly state what you understand by the term **solar energy** and how it would be utilised in this house.

[2]

(b) Give **two** reasons why the client has chosen to incorporate solar panels into the design of the house shown in the attached house plans.

1. _____
2. _____

[2]

Examiner Only	
Marks	Remark

5 State the function of the following **five** components used in the attached house plans and specifications. Also state where each component can be found in the construction of the building shown in the attached house plans.

(a) Insulation

[2]

(b) Damp-proof course

[2]

(c) Double glazing

[2]

(d) Cavity wall tie

[2]

(e) Architrave

[2]

Examiner Only	
Marks	Remark

6 (a) List **two** of the main functions of a foundation.

1. _____

2. _____

[2]

(b) What is a strip foundation?

_____ [3]

(c) The foundation trench shown in **Fig. 2** below has small wooden pegs projecting up from the base of the trench. Clearly state why these pegs have been driven into the bottom of the trench, and give a brief description of how the concrete is poured into the trench.

_____ [4]



Fig. 2

Examiner Only

Marks Remark

- (d) State why it may be necessary to provide a step in a foundation and relate this to how the step will affect the amount of material that has to be excavated from the foundation. **Fig. 3** may help you with your answer.

[2]



Fig. 3

- (e) Why is it sometimes necessary to place reinforcement in a foundation?

[2]

- (f) Why would you use a pile foundation in a construction project?

[2]

Examiner Only	
Marks	Remark

Section B

- 7 **Fig. 4** shows incomplete details for the window sill shown in the attached house plans. Complete the drawing and add the annotation to **Fig. 4** in the appropriate place using the list provided. [20]

Window sill
100 mm block outer leaf
DPC
Wall insulation
Sand and cement plaster with gypsum skim
Window frame
Double glazing
Wet dash
Plastic sill board
Anti capillary groove

Examiner Only

Marks Remark

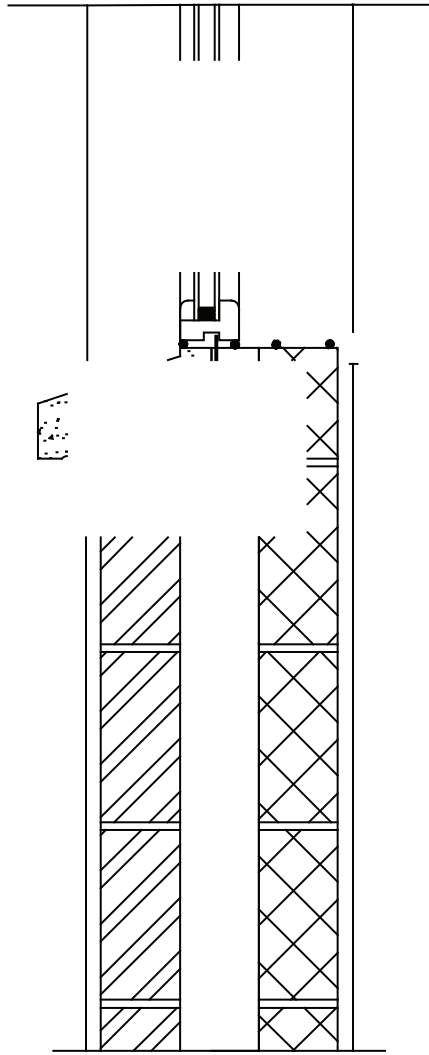

Fig. 4

Examiner Only	
Marks	Remark



Fig. 5

(a) Name the type of building structure shown in Fig. 5.

[2]

(b) List **four** types of buildings that this type of structure could be used for.

1. _____

2. _____

3. _____

4. _____

[4]

Examiner Only	
Marks	Remark

Structural detail where a column and a beam join.

[5]

Examiner Only

Marks Remark

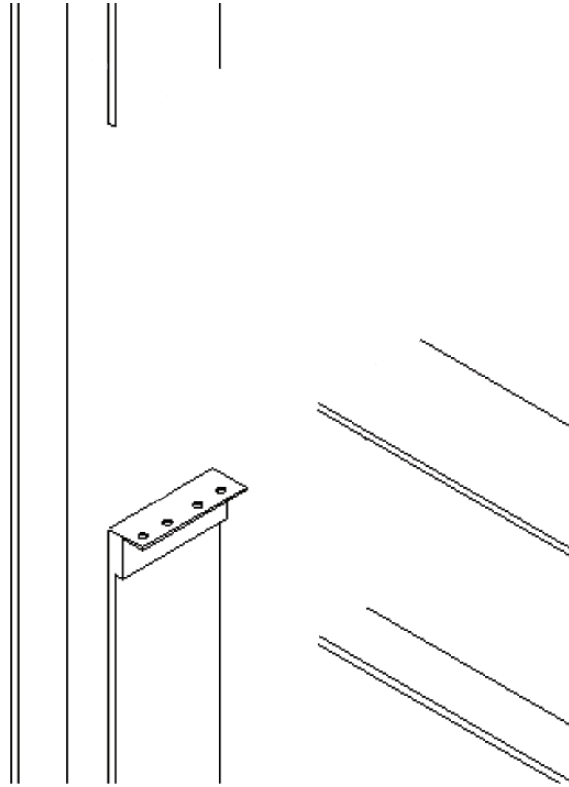

THIS IS THE END OF THE QUESTION PAPER

Permission to reproduce all copyright material has been applied for.
In some cases, efforts to contact copyright holders may have been unsuccessful and CCEA
will be happy to rectify any omissions of acknowledgement in future if notified.

ROOF CONSTRUCTION

Flat concrete interlocking tiles (colour: blue/black) on 38 x 25 mm treated s.w. battens on Monarfol 250 underlay on C16 grade rafters at 400 mm c/c on 100 x 50 mm treated wallplates. All structural timbers to be strength class C16 and kiln dried. Exposed timber to be vac-vac treated with vascol WR wood preservative or other equal and approved. Tie down wall plates with 38 x 5 mm galvanised mild steel straps at 1800 mm c/c. Lateral support to be provided to cavity walls with 38 x 5 mm mild steel straps fixed and carried across 3 no. joists at 2000 mm c/c at ceiling level and 1200 mm c/c along verge with solid bridging between rafters and joists. Provide softwood fascia and barge boards, and plywood soffit with ventilation grill providing 10mm min. continuous ventilation. Ceilings to be 12.5 mm plasterboard, 8 mm bonding and 3 mm skim finish. Provide 200 mm fibreglass insulation quilt to roofspace.

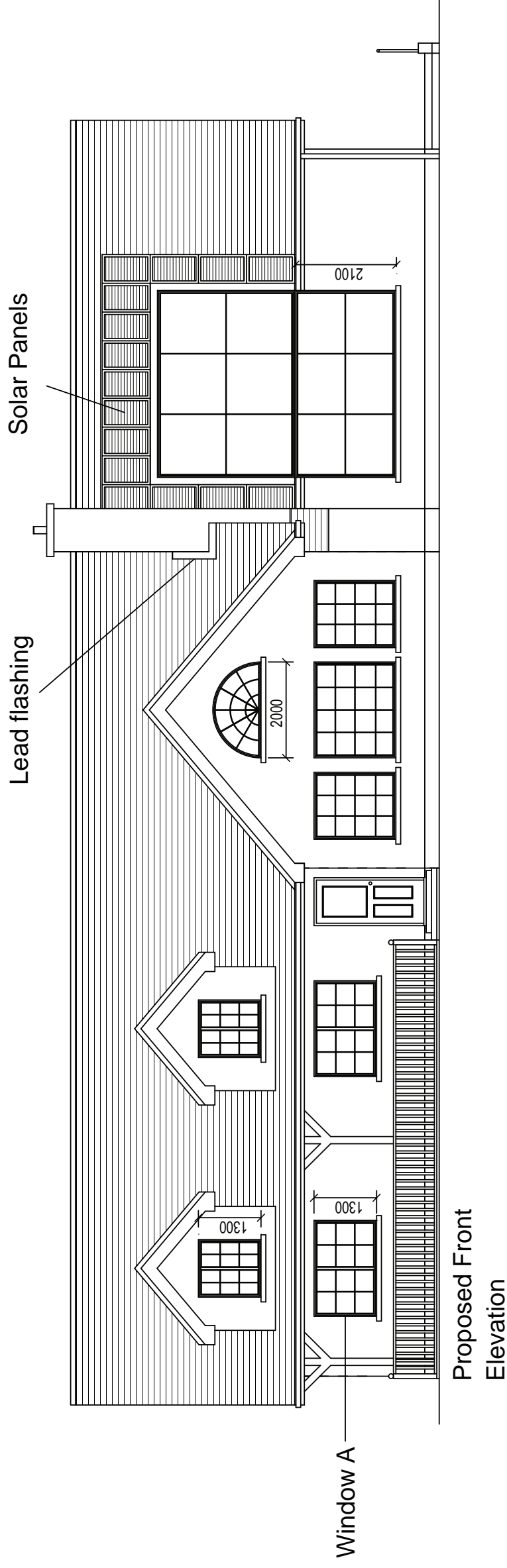

GCSE Construction
Pre-release drawings Front Elevation
Scale: 1:100
York House



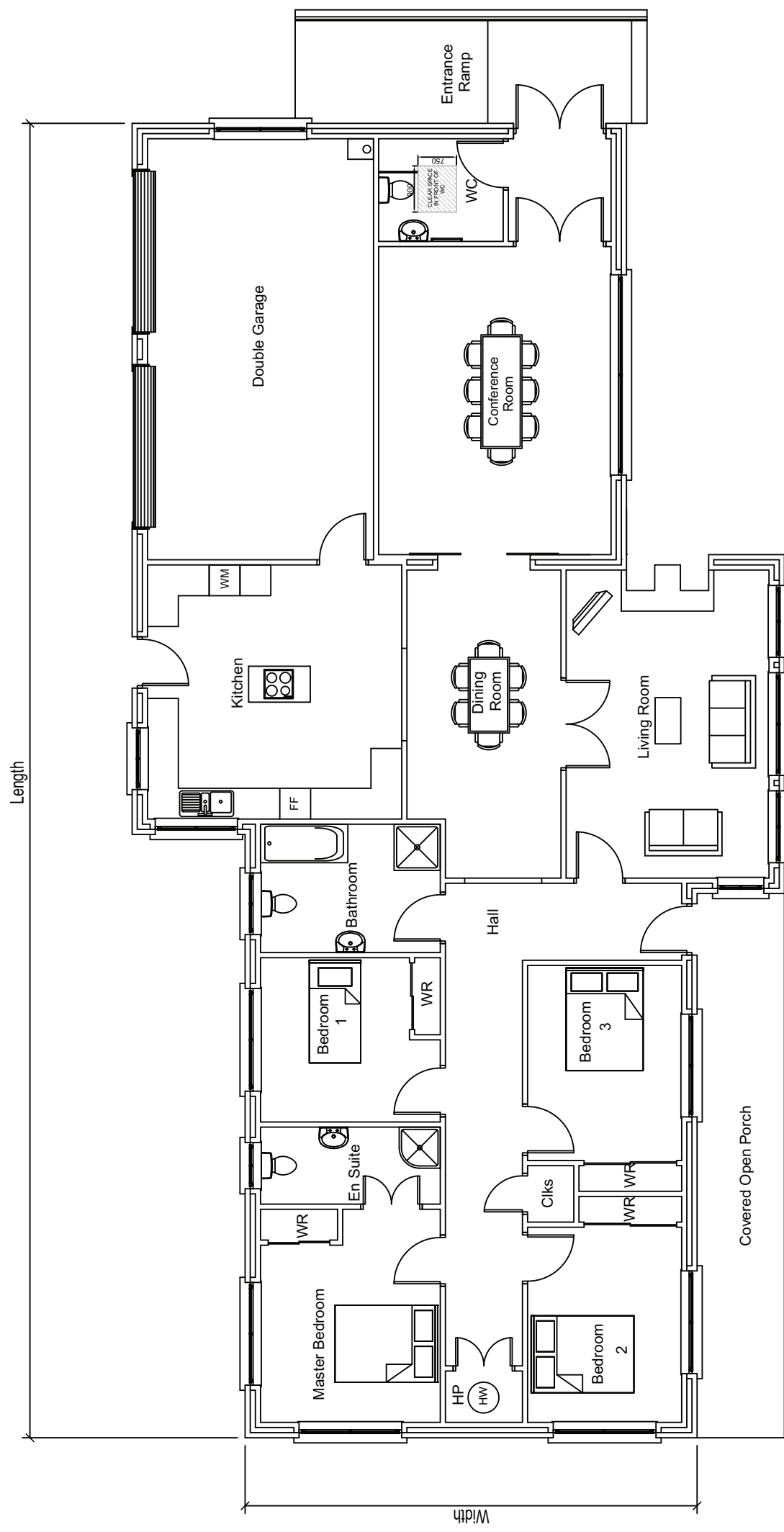

Proposed Floorplan

GCSE Construction
Pre-release drawings Plan view
Scale: 1:100
York House

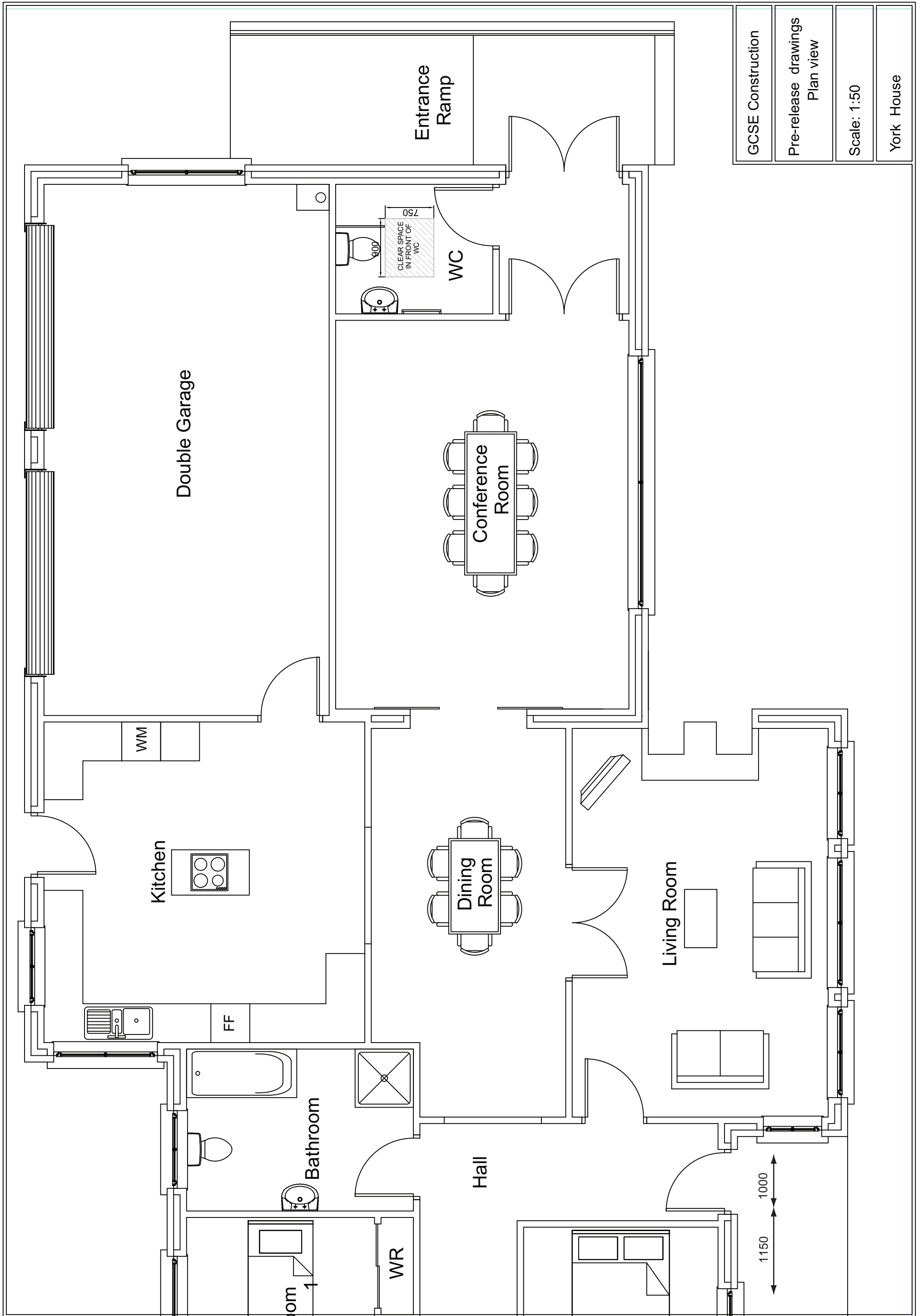

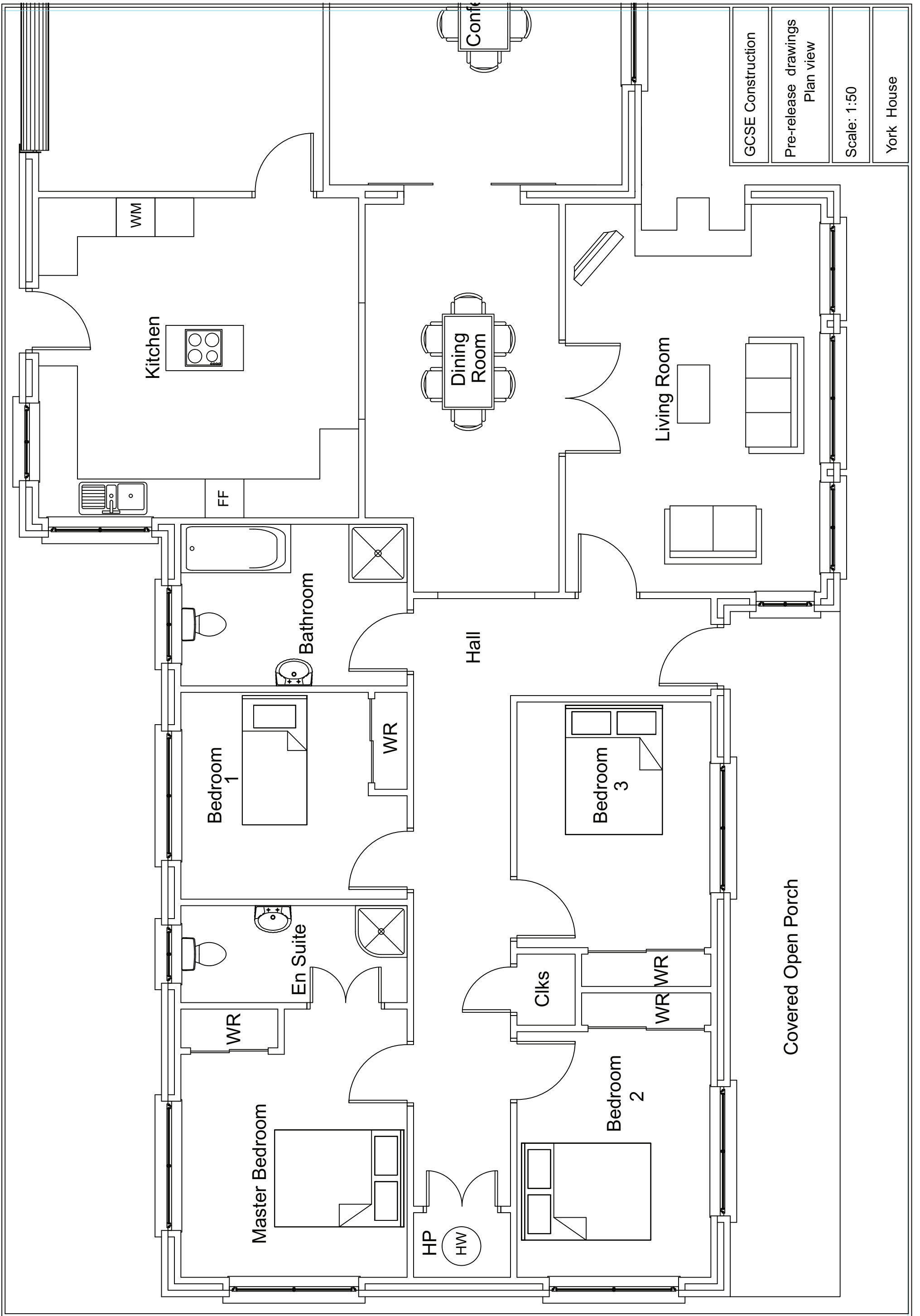

Foundations

The foundations have been designed to be adequate if the bearing is on subsoil Type III or better as defined in Section 5 Table 5.1 of Technical Booklet D of Building Regulations. Foundations shall be situated centrally under walls. Where foundations require to be stepped they shall overlap by twice the height of the step or the thickness of the foundation or 300 mm whichever is greater. Steps shall not be of greater height than the thickness of the foundation.

600 x 250 mm conc. strip foundations shall be used for 300 mm cavity walls.

450 x 200 mm conc. strip foundations shall be used for 100, 150, & 215 mm solid walls.

Foundations should be a min of 750 mm deep taken down to a firm bearing strata. If a suitable bearing cannot be achieved then an amended design will be submitted to the local authority as necessary.

Hardcore

The hardcore shall be a min of 150 mm deep at the highest point of infill to a max of 600 mm. Hardcore should be consolidated in 225 mm max. layers with a mechanical vibrator. If hardcore exceeds 600 mm deep, then precast or prestressed concrete T-Beams or similar slabs shall be used in accordance with manufacturer's details and these shall be submitted to Building Control 3 weeks prior to erection on site.

Ground Floor Construction

100 mm deep sand/cement screed on 500 gauge vapour control layer on 65 mm Kingspan TF70 insulation on 100 mm concrete floor slab on 1200 gauge dpm/radon membrane on sand blinding on hardcore as above. Note: 25 mm Thermafloor TF70 should be provided to perimeter of the floor to eliminate cold bridging.

Brick/Block Cavity Walls

Cavity walls shall be 300 mm thick overall with a 100 mm cavity. Wall ties shall be stainless steel suitable for 100 mm cavity with p.v.c. retainer disc for insulation. Ties shall be positioned at 750 mm centres horizontally and 450 mm centres vertically and staggered. Additional ties should be provided at reveal at 215 mm centres vertically.

Butterfly wire stainless steel wall ties should be used in separating walls at centres as before. Cavities and wall ties should be kept clean of mortar droppings. Provide patented expansion joints horizontally every 6 m in facing brick and 8 m in blockwork. Weep holes should also be provided in vertical perpend of facing brick heads as necessary. D.P.C.'s should overlap and be bonded to dpm and be a min of 150 mm above finished ground levels.

Lintels

Prestressed or R.C. lintels should be used in openings up to 2.500 m in accordance with concrete manufacturer's specifications. Keystone SK/90 lintels should be used over openings greater than 2.500 m to the max. span and loadings recommended by the manufacturer and have 225 mm end bearing. Where P.C. floor slabs are used the lintels should be in accordance with the structural engineer's calcs./recommendations.

First Floor Construction

18 mm t & g flooring grade plywood on joists to sizes indicated on layout plan at 400 mm centres with herringbone bridging at 2.400 m centres. Provide double joists under stud walls that run parallel to direction of joists and bridging to those at right angles. Trimming and trimmer joists to stairwell and chimney stack to be 75 mm thick x depth of joist unless otherwise stated on plan.

Ground floor ceilings should be finished using 12.5 mm plasterboard bonding and skim.

Internal Stud Walls

To have 100 x 50 mm head and sole plates with 100 x 38 mm s.w. vertical studs at 400 mm centres vertically with horizontal solid budging at 1.2 m centres. Walls to be insulated with 100 mm rockwool or similar sound insulation where necessary and sheeted either side with 9.5 mm plasterboard bonded and skim.

Structural studs to be faced with 18 mm grade ply to one face and bolted to blockwork with M8 Bolts at 450 mm max centres. Walls to shower and other areas to be tiled to receive either moisture resistant plasterboard or 18 mm external grade plywood faced with building paper, expanded mental lath and sand/cement.

Dormer Roof

Provide roof covering as indicated on elevations on 38 x 25 mm s.w. pressure impregnated battens on Tyvec or similar breathable underlay on 100 x 50 mm rafters and ceiling joists at 400 mm crs. supported on 100 x 50 mm head and sole plates with 100 x 38 mm vertical studs at 400 mm crs. Provide double/triple rafters to supporting stud walls of dormers. Finish the dormer as indicated on elevations on galvanised expanded metal lath on breather felt on 19 mm external grade ply. Dormer walls to be insulated using 100 mm thick Kingspan Thermapitch TP10 between vertical studs and 25 mm ThermaWall TW56 to internal face, 500 gauge vapour barrier and 9.5 mm plasterboard bonding and skim.

GCSE Construction

Pre-release drawings
Front Elevation

Scale: 1:100

York House



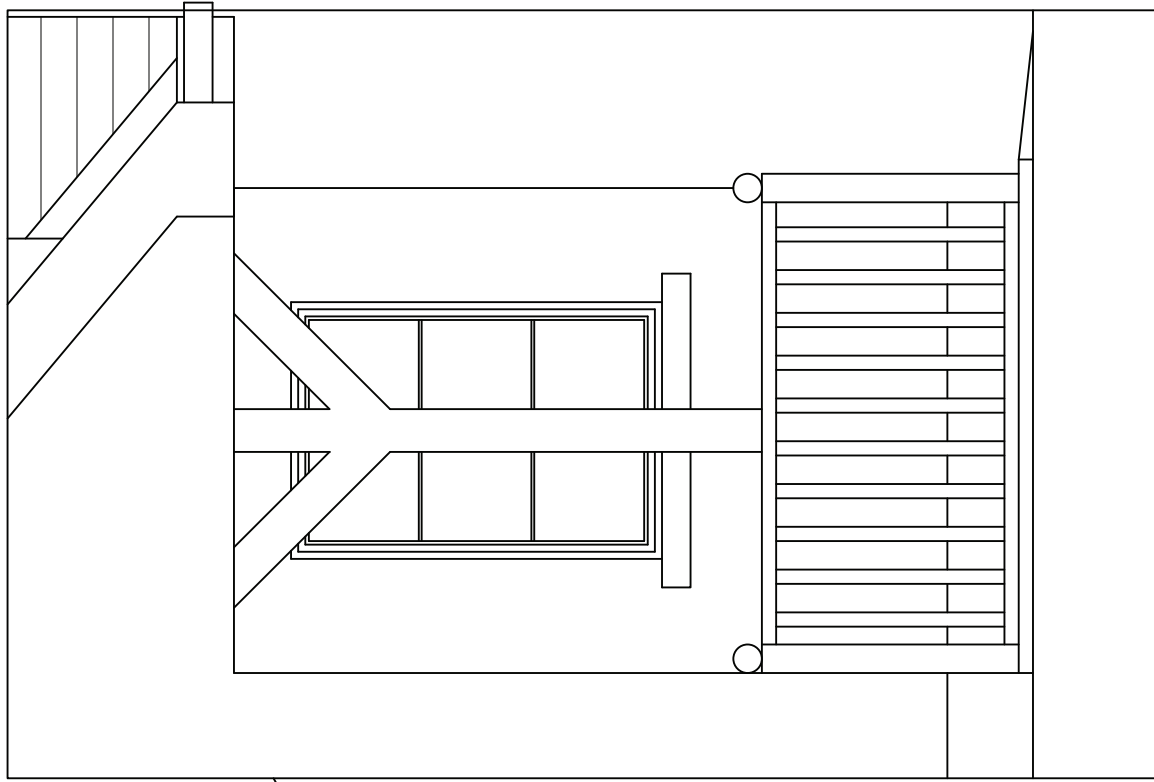
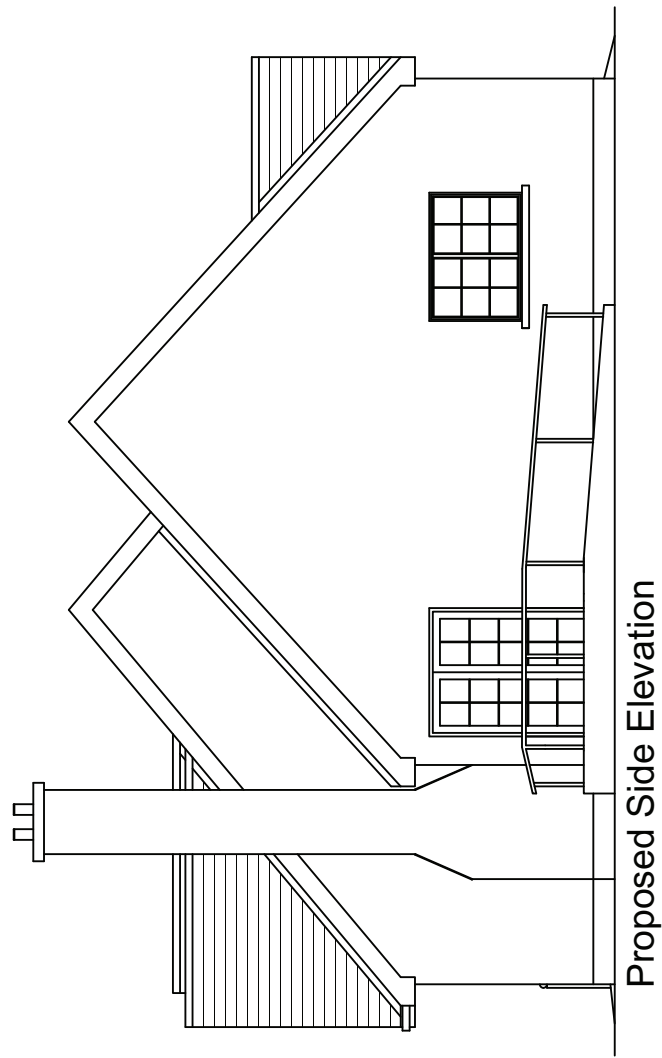
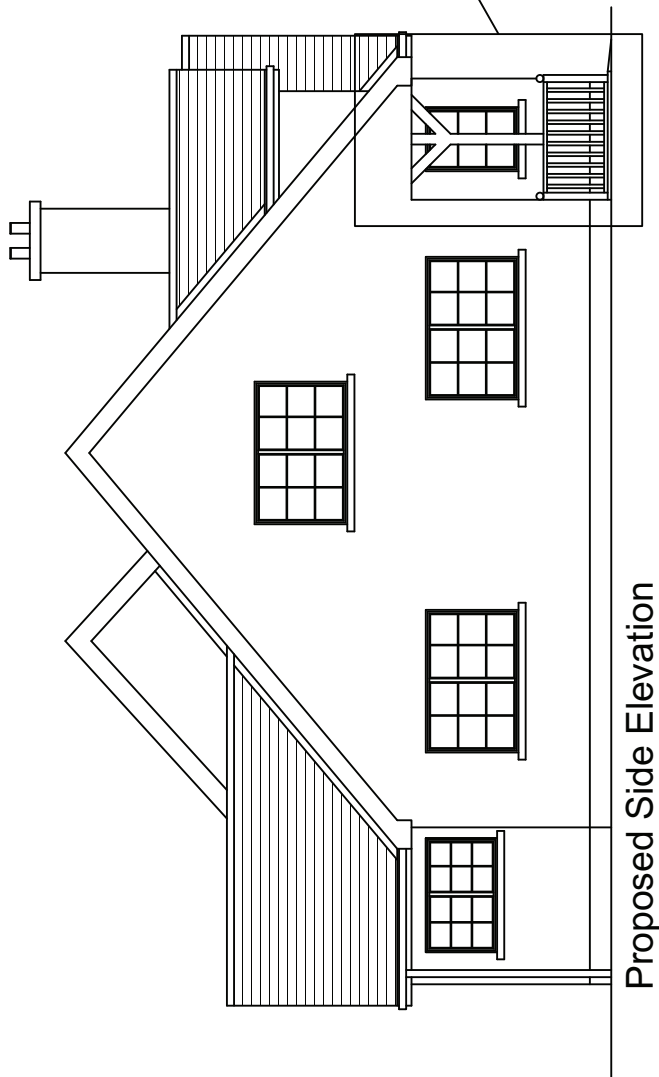

GCSE Construction

Pre-release drawings
End Elevations

Scale: 1:100

York House

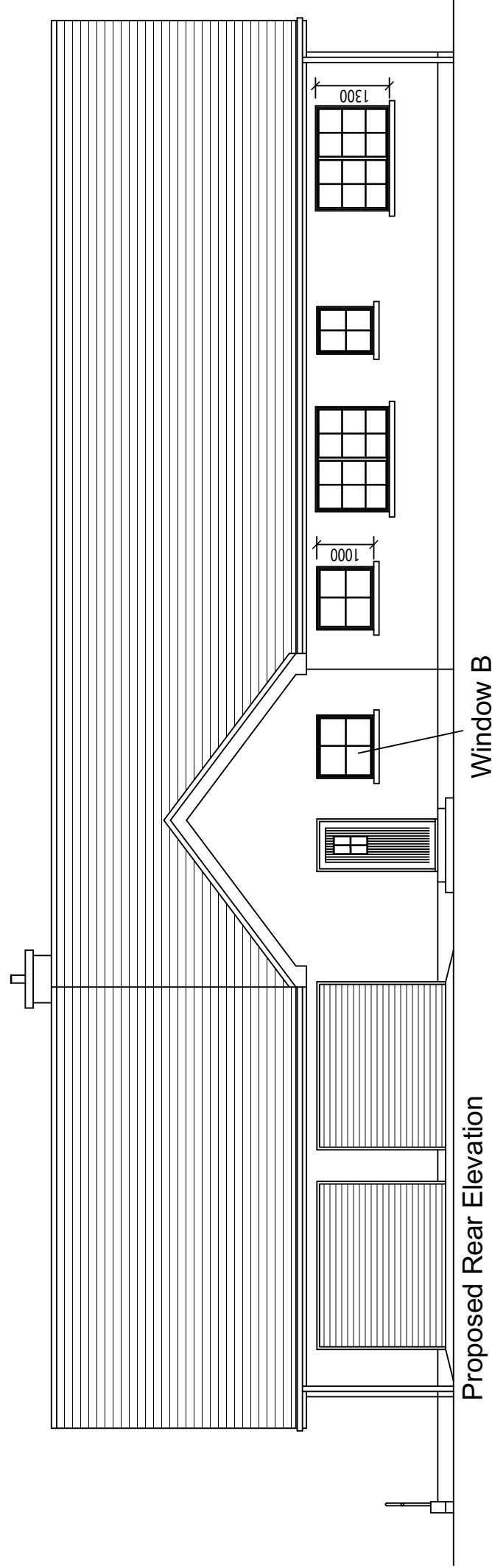

Proposed Rear Elevation

Window B

GCSE Construction

Pre-release drawings
Front Elevation

Scale: 1:100

York House