

**GENERAL CERTIFICATE OF SECONDARY EDUCATION
GATEWAY SCIENCE
CHEMISTRY B**

B642/01

Unit 2 Modules C4 C5 C6 (Foundation Tier)

**Wednesday 27 January 2010
Afternoon**

Duration: 1 hour

Candidates answer on the Question Paper
A calculator may be used for this paper

OCR Supplied Materials:
None

Other Materials Required:

- Pencil
- Ruler (cm/mm)



Candidate Forename		Candidate Surname	
--------------------	--	-------------------	--

Centre Number						Candidate Number				
---------------	--	--	--	--	--	------------------	--	--	--	--

INSTRUCTIONS TO CANDIDATES

- Write your name clearly in capital letters, your Centre Number and Candidate Number in the boxes above.
- Use black ink. Pencil may be used for graphs and diagrams only.
- Read each question carefully and make sure that you know what you have to do before starting your answer.
- Answer **all** the questions.
- Do **not** write in the bar codes.
- Write your answer to each question in the space provided, however additional paper may be used if necessary.

INFORMATION FOR CANDIDATES

- The number of marks is given in brackets [] at the end of each question or part question.
- The Periodic Table is printed on the back page.
- The total number of marks for this paper is **60**.
- This document consists of **24** pages. Any blank pages are indicated.

BLANK PAGE

PLEASE DO NOT WRITE ON THIS PAGE

Answer **all** the questions.

Section A – Module C4

1 Fullerenes are one form of carbon.

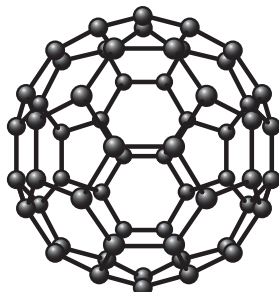

(a) Which of the following is the molecular formula of Buckminster Fullerene?

Choose from:

- C_2 C_8 C_{30} C_{60} C_{68}

answer [1]

(b) Write down the name of one **other** form of carbon.

..... [1]

(c) Fullerenes can be joined together to make nanotubes.

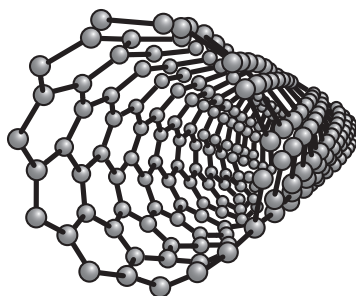

Nanotubes are used to reinforce graphite in tennis rackets.

(i) One property of nanotubes is that they conduct electricity.

Write down one **other** property of nanotubes.

..... [1]

(ii) Write down one **other** use of nanotubes.

..... [1]

[Total: 4]

Turn over

2 Farmers use fertilisers to make their plants grow bigger and faster.

Look at the table. It gives information about some fertilisers.

fertiliser	formula	relative formula mass	percentage by mass of nitrogen	percentage by mass of phosphorus	percentage by mass of potassium
ammonium nitrate	NH_4NO_3	80	35	0	0
ammonium phosphate	$(\text{NH}_4)_3\text{PO}_4$	149	28	21	0
potassium nitrate	KNO_3	101	14	0	39
potassium phosphate	K_3PO_4	212	0	15	55
urea	$(\text{NH}_2)_2\text{CO}$		47	0	0

Fertilisers contain one or more of the essential chemical elements.

These elements are nitrogen, phosphorus and potassium.

(a) Two fertilisers contain phosphorus. Which **two**?

Choose from the table.

..... and [1]

(b) Which fertiliser contains the **greatest** percentage by mass of potassium?

Choose from the table.

..... [1]

(c) A farmer wants to use fertiliser on some fields.

The farmer uses a mixture of potassium phosphate and ammonium nitrate.

This mixture is better than using **only** ammonium nitrate.

Suggest why.

.....
 [1]

(d) Which part of a plant absorbs fertilisers?

..... [1]

(e) Maddy wants to make potassium nitrate by neutralising an acid with an alkali.

She decides to use potassium hydroxide as the alkali.

Which **acid** should she use?

..... [1]

(f) Calculate the relative formula mass (M_r) of urea, $(\text{NH}_2)_2\text{CO}$.

The relative atomic mass (A_r) of H is 1, of C is 12, of N is 14 and of O is 16.

.....
.....
.....
.....

relative formula mass = [1]

[Total: 6]

3 Methanol is an important **solvent**.

(a) What is a solvent?

.....
 [1]

(b) Look at the flow chart. It shows how methanol can be made.

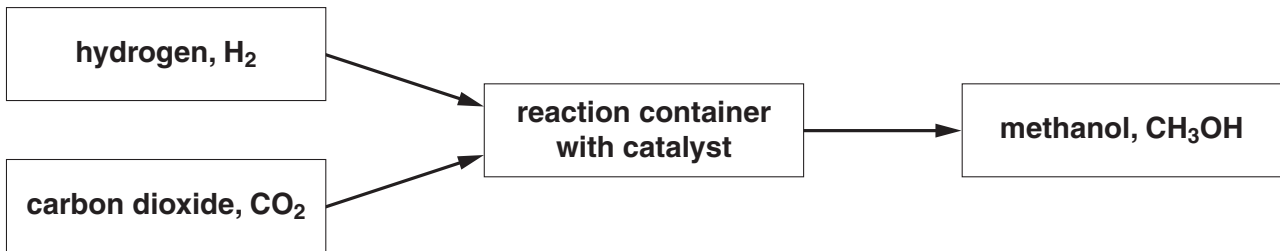

(i) Write down the **word** equation for the making of methanol.

..... [1]

(ii) Write about some of the costs of making methanol.

.....

 [3]

(c) Look at the table. It gives some information about making methanol.

	catalyst used	temperature used in °C	pressure used in atmospheres
method 1	a mixture of zinc oxide and chromium(III) oxide	400	300
method 2	copper based substance	250	70

Both methods use the reaction between carbon dioxide and hydrogen to make methanol.

Making methanol using **method 2** is **cheaper** than using method 1.

Suggest one reason why.

..... [1]

(d) Methanol is made in a **continuous process**.

(i) What is a continuous process?

..... [1]

(ii) Write the name of another chemical that is made in a continuous process.

..... [1]

[Total: 8]

4 Copper carbonate decomposes when heated.

Copper oxide and carbon dioxide are made.

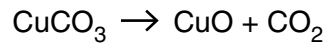

Tim investigates this decomposition.

Look at the apparatus he uses.

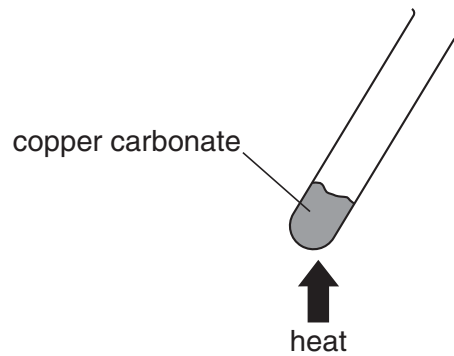

He heats 1.0g of copper carbonate in the test tube.

He uses a blue Bunsen flame for 1 minute.

(a) Tim finds out he only gets a 90% yield of copper oxide.

Suggest a possible reason why he did not get a 100% yield.

.....
 [1]

(b) Tim repeats the experiment.

This time he uses 2.0g of copper carbonate.

What happens to the mass of copper oxide made?

Choose from:

decreases

increases

stays the same

answer [1]

[Total: 2]

Section B – Module C5

5 This question is about precipitation reactions.

(a) Lead nitrate solution reacts with potassium iodide solution.

A bright yellow precipitate is made.

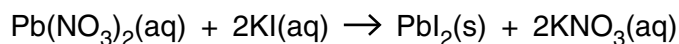

Write down the formula of the product that is a solid.

..... [1]

(b) Silver nitrate solution reacts with halide ions to make a precipitate.

Draw a straight line to join each **halide ion** to the **colour of precipitate**.

halide ion	colour of precipitate
chloride ion, Cl^-	yellow
bromide ion, Br^-	cream
iodide ion, I^-	white

[2]

(c) A solution of sodium chloride reacts with a solution of silver nitrate.

Solid sodium chloride does not react with **solid** silver nitrate.

Explain why the solutions react but the solids do not.

Use ideas about collisions between ions.

.....

 [2]

[Total: 5]

6 Ellen investigates the properties of two acids.

They are dilute hydrochloric acid and dilute ethanoic acid.

In each experiment Ellen uses the same concentration of acid.

(a) Look at Ellen's results table.

It is not finished.

Predict the two missing results and write them in the table.

test	result with dilute hydrochloric acid	result with dilute ethanoic acid
pH value	1
reaction with magnesium ribbon	bubbles rapidly to make hydrogen	bubbles slowly to make hydrogen
reaction with calcium carbonate powder	bubbles slowly to make carbon dioxide

[3]

(b) Ellen also investigates the electrolysis of the two acids.

Look at the apparatus she uses.

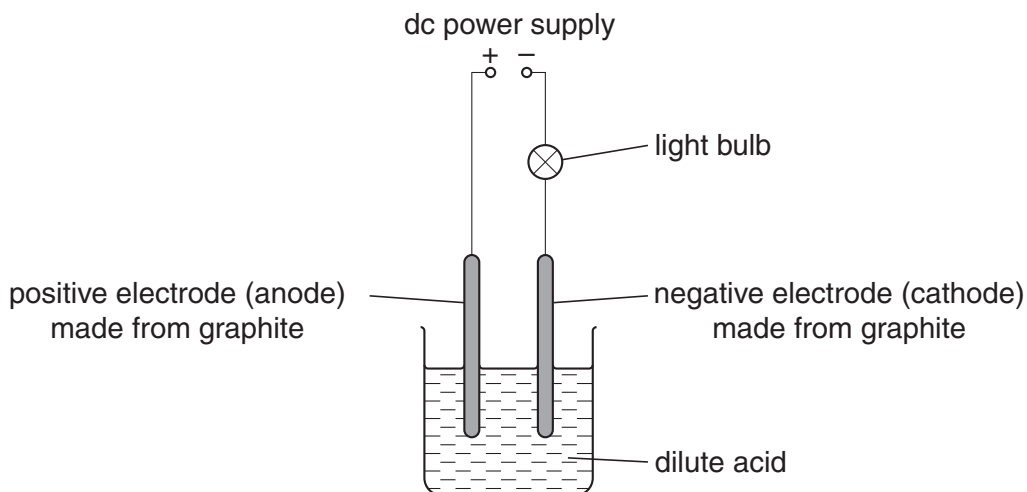

(i) Ellen electrolyses dilute **ethanoic** acid.

Ellen then electrolyses dilute **hydrochloric** acid.

The same gas is made at the negative electrode in each experiment.

What is the name of this gas?

..... [1]

(ii) Ellen uses the same concentration of both acids.

She finds that the light bulb glows much more brightly with dilute hydrochloric acid.

Explain why.

Use ideas about ions.

..... [1]

[Total: 5]

- 7 Hydrogen peroxide solution decomposes when a catalyst is added to it.

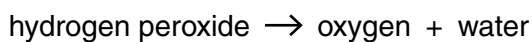

Look at the diagram.

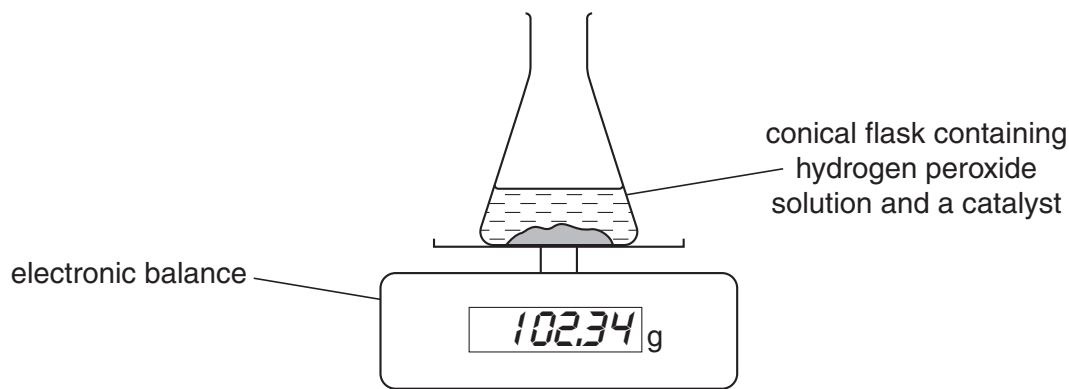

Elliott measures the mass of the contents of the conical flask at the start of the reaction.

Once the reaction has finished Elliott measures the mass of the contents of the conical flask again.

Look at the results table.

	mass in grams
contents of conical flask at start of reaction	102.34
contents of conical flask at end of reaction	102.24

- (a) The mass of the contents of the conical flask decreases.

Explain why.

.....
 [1]

- (b) The reaction of hydrogen peroxide eventually stops.

Explain why.

..... [1]

(c) Elliott wants to measure the **volume** of oxygen made.

Draw a labelled diagram of the apparatus that he could use.

[2]

[Total: 4]

- 8 This question is about acid-base titrations.

Aliena wants to find the volume of potassium hydroxide solution needed to neutralise 10.0 cm^3 of dilute hydrochloric acid.

Look at the apparatus she uses.

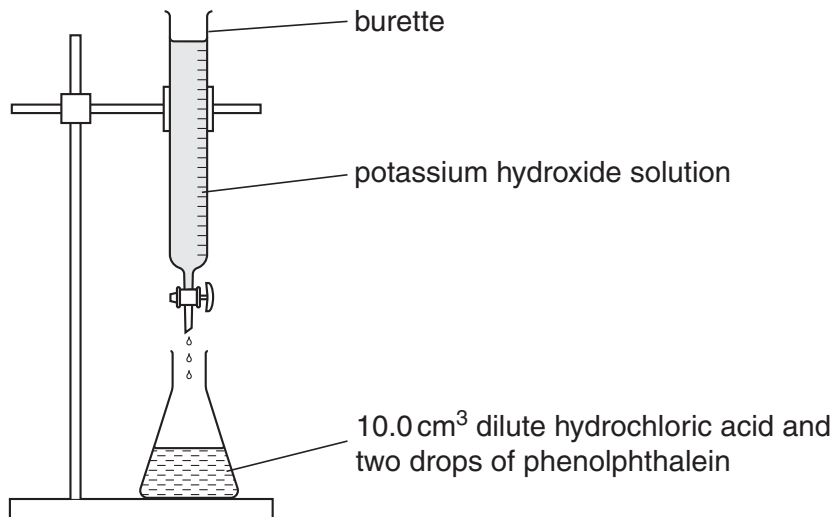

- (a) What piece of apparatus should Aliena use to measure out the hydrochloric acid?

Choose from:

100 cm³ beaker

100 cm³ gas syringe

10.0 cm³ pipette

25.0 cm³ pipette

answer [1]

- (b) She adds the potassium hydroxide solution slowly until the phenolphthalein changes colour.

What is the colour of phenolphthalein in acid and in alkali?

Choose from:

blue

colourless

pink

purple

yellow

colour in acid

colour in alkali [1]

- (c) Phenolphthalein is an acid-base indicator.

Write down the name of another acid-base indicator.

..... [1]

- (d) Aliena repeats the experiment two more times.

Look at her results table.

titration number	1	2	3
final burette reading in cm ³	26.0	27.6	28.2
initial burette reading in cm ³	0.5	2.5	3.3
titre (volume of acid used) in cm ³	25.1	24.9

- (i) Calculate the titre for titration number 1.

Write your answer in the results table.

[1]

- (ii) Calculate the **average** titre for titration numbers 2 and 3.

.....

average titre = cm³

[1]

- (e) The pH value of the dilute hydrochloric acid increases as more potassium hydroxide is added.

Explain why.

.....
 [1]

[Total: 6]

Section C – Module C6

- 9 Sarah investigates the electrolysis of concentrated sodium chloride solution.

Look at the apparatus she uses.

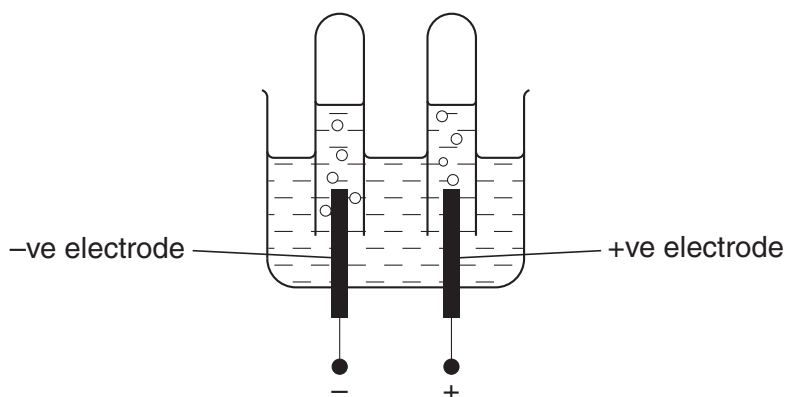

- (a) Bubbles of gas are made at both electrodes.

Chlorine is one of the gases made.

Write down the name of the **other** gas made during the electrolysis.

Choose from the list.

carbon dioxide hydrogen nitrogen oxygen

answer [1]

- (b) Chlorine is a very important chemical.

It has many uses.

Write down one use of chlorine.

..... [1]

[Total: 2]

10 Sarah and Daniel investigate fermentation.

Look at the diagram.

It shows the apparatus they use.

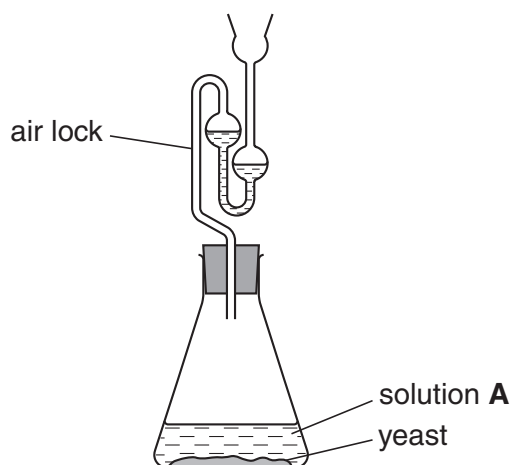

(a) Ethanol is made by fermentation.

Yeast and solution **A** are used to make ethanol.

Write down the name of solution **A**.

..... [1]

(b) A gas is made during fermentation.

Write down the name of this gas.

..... [1]

(c) Fermentation happens in the presence of yeast.

Write down two **other** conditions needed for fermentation.

1

2 [2]

(d) Look at the **displayed formula** of ethanol.

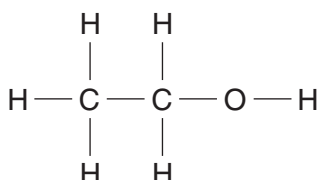

Write down the **molecular formula** of ethanol.

..... [1]

[Total: 5]

Turn over

11 Look at the picture of a car.

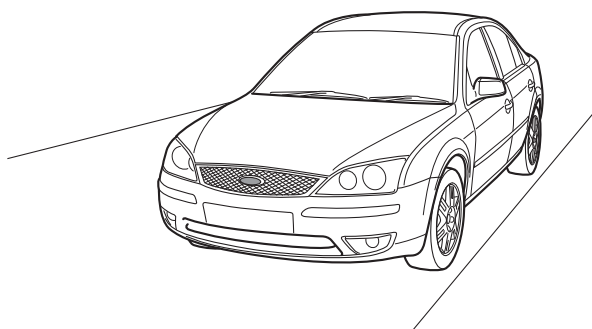

(a) Some of the car body is made of iron.

One disadvantage of using iron is that it rusts.

Oxygen and water are needed for rusting to happen.

Hydrated iron(III) oxide is made.

Write a **word** equation for the rusting of iron.

..... [1]

(b) What **type** of reaction is rusting?

Choose from the list.

dehydration

displacement

electrolysis

redox

saponification

answer [1]

(c) Write about **two** methods of preventing rusting.

.....
.....
..... [2]

[Total: 4]

12 Look at the diagram of a fuel cell.

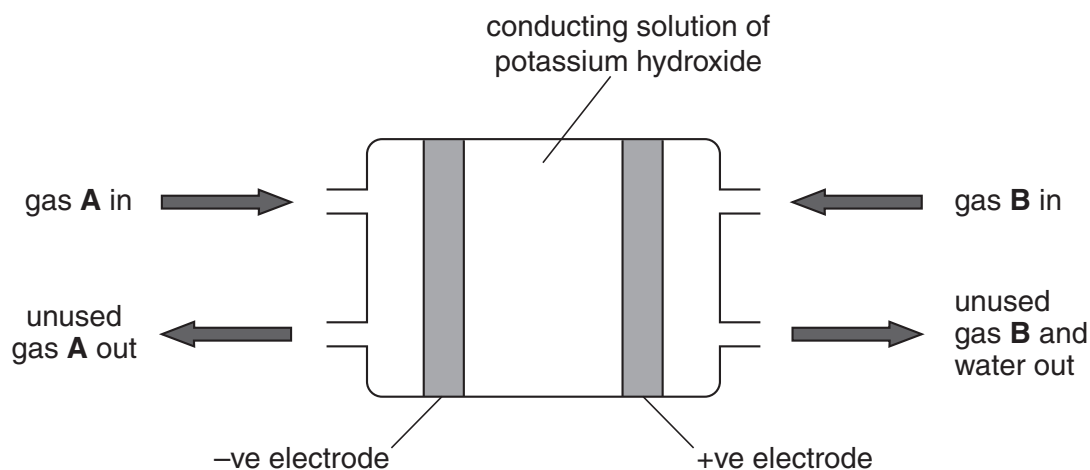

A fuel cell produces electrical energy.

(a) This fuel cell uses two gases to produce an electric current.

Look at the word equation for the reaction in this fuel cell.



Name the two gases, **A** and **B**, used in this fuel cell.

..... and [1]

(b) A car engine burning petrol makes carbon dioxide and water.

Carbon dioxide is a greenhouse gas.

Write down one benefit of using a fuel cell instead of a petrol engine.

.....
 [1]

[Total: 2]

13 This question is about hardness in water.

Luke and Henry investigate the hardness of three different samples of water.

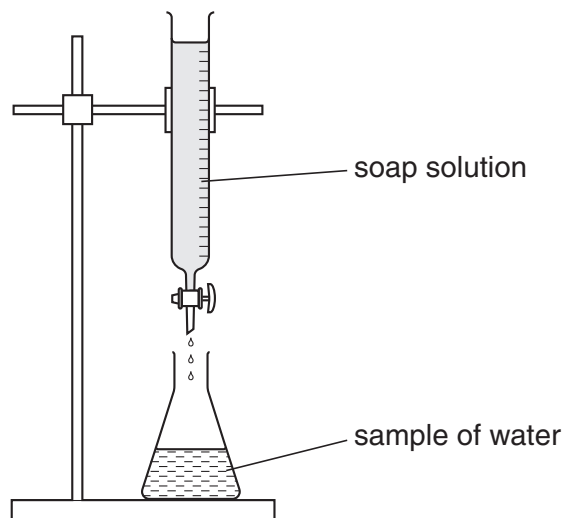

They do this by adding drops of soap solution to each sample of water.

They add soap until lather remains on the surface after shaking.

Look at their table of results.

sample of water	volume of soap added in cm ³
tap water	30
river water	28
boiled tap water	15
distilled water	5

(a) Which sample of water is the softest?

Choose from the table.

..... [1]

(b) Tap water contains **both** temporary hardness and permanent hardness.

Explain how you can tell from the results.

.....

 [1]

(c) Describe what happens when the tap water is boiled.

.....
..... [1]

(d) Hardness is caused by dissolved ions in the water.

Put **rings** round the names of **two** ions which cause hardness.

- calcium
- carbonate
- chloride
- hydrogen
- magnesium

[2]

[Total: 5]

14 Aspirin is a widely used medicine.

Aspirin affects the body in a number of ways.

Write about **two** of the reasons why people take aspirin.

.....
.....
..... [2]

[Total: 2]

END OF QUESTION PAPER

PLEASE DO NOT WRITE ON THIS PAGE

PLEASE DO NOT WRITE ON THIS PAGE



Copyright Information

OCR is committed to seeking permission to reproduce all third-party content that it uses in its assessment materials. OCR has attempted to identify and contact all copyright holders whose work is used in this paper. To avoid the issue of disclosure of answer-related information to candidates, all copyright acknowledgements are reproduced in the OCR Copyright Acknowledgements Booklet. This is produced for each series of examinations, is given to all schools that receive assessment material and is freely available to download from our public website (www.ocr.org.uk) after the live examination series.

If OCR has unwittingly failed to correctly acknowledge or clear any third-party content in this assessment material, OCR will be happy to correct its mistake at the earliest possible opportunity.

For queries or further information please contact the Copyright Team, First Floor, 9 Hills Road, Cambridge CB2 1GE.

OCR is part of the Cambridge Assessment Group; Cambridge Assessment is the brand name of University of Cambridge Local Examinations Syndicate (UCLES), which is itself a department of the University of Cambridge.

