

GENERAL CERTIFICATE OF SECONDARY EDUCATION
TWENTY FIRST CENTURY SCIENCE
CHEMISTRY A

Unit 1 Modules C1 C2 C3 (Foundation Tier)

SAMPLE ASSESSMENT MATERIALS

(from 2010 onwards)

Time: 40 minutes

Candidates answer on the question paper

Additional materials (enclosed):

None

Calculators may be used.

Additional materials: Pencil
 Ruler (cm/mm)

Candidate
 Forename

--

Candidate
 Surname

--

Centre
 Number

--	--	--	--	--

Candidate
 Number

--	--	--	--

INSTRUCTIONS TO CANDIDATES

- Write your name in capital letters, your Centre Number and Candidate Number in the boxes above.
- Use black ink. Pencil may be used for graphs and diagrams only.
- Read each question carefully and make sure you know what you have to do before starting your answer.
- Answer **all** the questions.
- Do **not** write in the bar codes.
- Do **not** write outside the box bordering each page.
- Write your answer to each question in the space provided.

INFORMATION FOR CANDIDATES

- The number of marks for each question is given in brackets [] at the end of each question or part question.
- The total number of marks for this paper is **42**.
- The Periodic Table is printed on the back page.

FOR EXAMINER'S USE

Qu.	Max.	Mark
1	8	
2	6	
3	8	
4	7	
5	2	
6	7	
7	4	
TOTAL	42	

This document consists of **17** printed pages and **3** blank pages.

Answer **all** the questions.

- 1 Cars on motorways use the right hand lane for overtaking. The left hand lanes are used for slower vehicles.

From 2007, car pool lanes will be introduced on some motorways. Only cars with two or more people in them will be allowed to drive in the right hand lane.



- (a) Explain how the car pool lane may reduce air pollution.

.....
.....
.....
.....
..... [3]

- (b) Polluting gases from car engines include:

- carbon dioxide
- carbon monoxide
- nitrogen oxides

Which of these will be reduced if there are fewer cars on motorways?

Put a (ring) around the correct answer.

all of them

carbon dioxide only

none of them

[1]

- (c) Pollution from cars is reduced by using catalytic converters.

Catalytic converters change carbon monoxide to carbon dioxide and change nitrogen oxides to nitrogen.

How do the amounts of gases produced by a car change when a catalytic converter is used?

Put ticks (✓) in the correct boxes in the table.

	decreases	increases	stays the same
carbon dioxide			
carbon monoxide			
nitrogen oxides			

[2]

- (d) Petrol is made up of compounds of carbon and hydrogen **only**.

- (i) What is the name given to these compounds?

Put a (ring) around the correct answer.

carbohydrates

hydrocarbons

polymers

[1]

- (ii) When petrol burns, the **carbon** atoms react with oxygen to make carbon dioxide.

Finish the diagram to show the reaction.

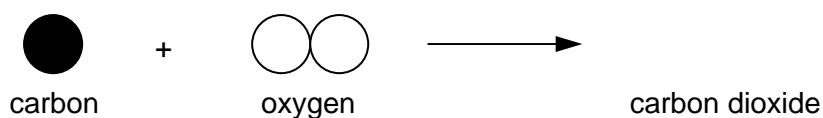

[1]

[Total: 8]

2 This question is about pollution from power stations.

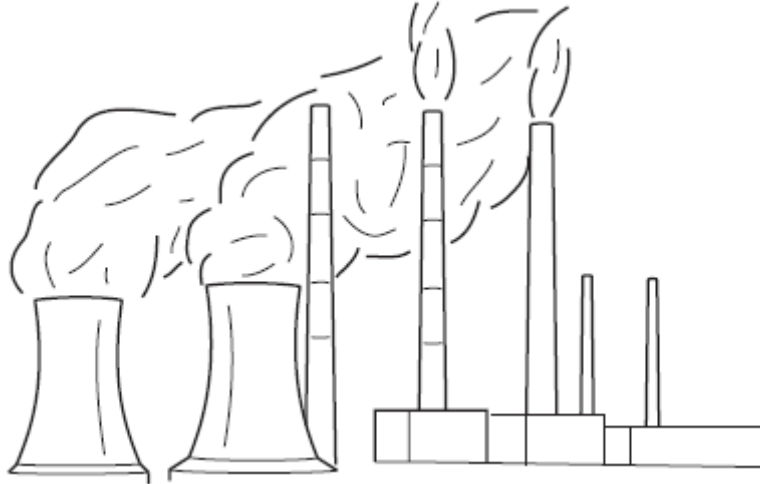

One of the pollutants from power stations is sulfur dioxide.

Sulfur dioxide levels are measured at different distances from a power station. The table shows the results on one day.

distance from power station in metres	concentration of sulfur dioxide in $\mu\text{g} / \text{m}^3$
0	64
500	50
1000	14
1500	8
2000	3

(a) Levels of sulfur dioxide higher than $50 \mu\text{g} / \text{m}^3$ are considered harmful to humans.

Where was the air harmful?

Put ticks (\checkmark) in the boxes next to the **two** correct answers.

At the power station.

Less than 500 metres from the power station.

More than 500 metres from the power station.

Between 500 metres and 1000 metres from the power station.

[2]

(b) Here is what five students said about the data in the table.

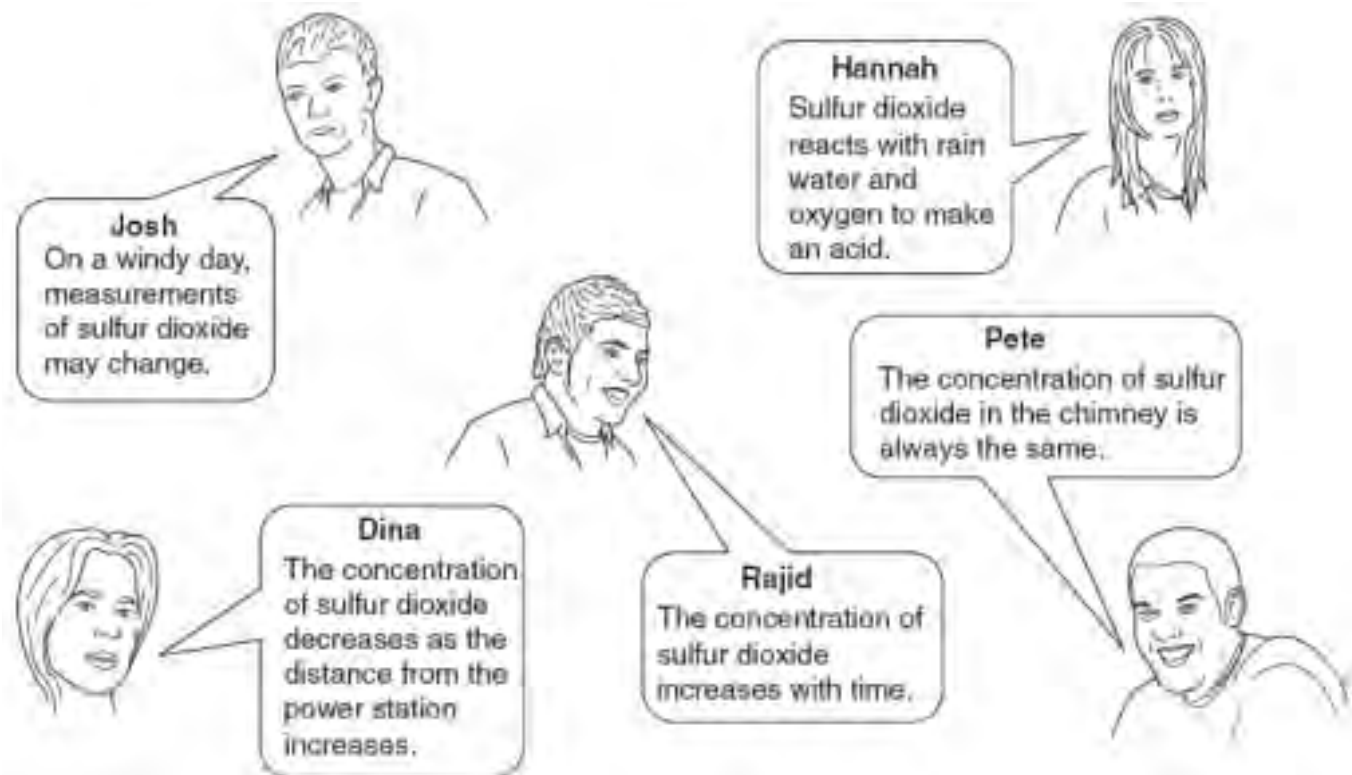

(i) Which **one** person has described the correlation in the table?

..... [1]

(ii) On another day, the concentrations of sulfur dioxide are lower.

Which **two** people have suggested explanations for this change?

..... [2]

(iii) Who has explained how sulfur dioxide is removed from the air?

..... [1]

[Total: 6]

3 Julie and Sam are designing a new rocking horse for a toy company.

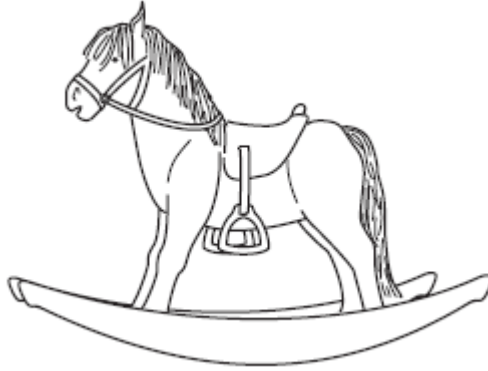

The rocking horse will be used by children between three and eight years old.

They should be able to move it around.

It must be strong enough to sit on.

It must not be dangerous.

It must be cheap to buy.

They test a number of materials.

The table gives the results of these tests.

material	strength	density	flexibility	cost
iron	very strong	high	low	medium
polypropylene	strong	low	high	low
wood	strong	medium	medium	high

They choose to make the rocking horses with polypropylene.

(a) Use information from the table to explain why polypropylene is a better material than iron for making a rocking horse.

.....

.....

.....

.....

.....

.....

.....

.....

.....

..... [4]

- (b) Julie says it would be better for the environment if the rocking horses were made of wood.

Which of the following explains this?

Put a tick (✓) in the box next to the **best** answer.

Wood is a natural material.

Wood has to be carved into shape.

Wood is strong.

Wood is a renewable material.

[1]

- (c) Sam says there are three different ways of getting rid of the polypropylene rocking horse at the end of its life. These will also affect the environment.

Finish the sentences. Choose words from this list.

burned
disposed
energy
landfill
products
recycled
rot
rust

The polypropylene rocking horse can be dumped in

where it will not

It can be put in an incinerator and

It can be to make new products.

[3]

[Total: 8]

4 A scientist measures the hardness of two different materials, X and Y.

A machine presses a steel point into samples of each material.

The machine uses the same force each time.

A hardness number is calculated from the size of the dent in the sample: the higher the number the harder the material.

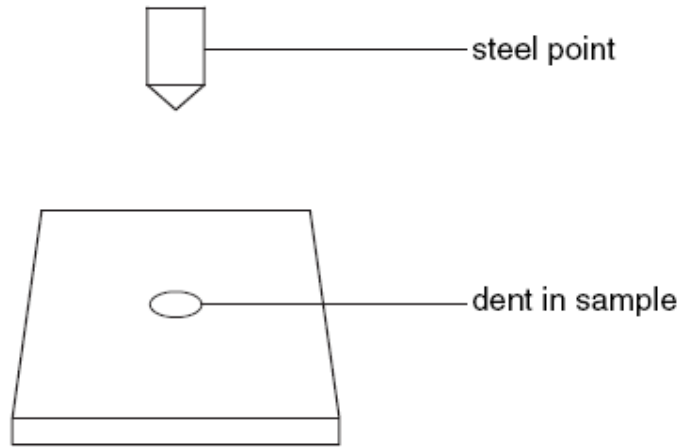

(a) Each type of material is tested several times. The results are shown in the table.

material	hardness number						mean
	sample 1	sample 2	sample 3	sample 4	sample 5	sample 6	
X	8	10	9	8	7	12	9
Y	18	20	16	7	21	20	19

The mean hardness has been calculated for each material.

One result has not been used to calculate the mean for **material Y** because it is an outlier.

(i) Which result is the outlier?

Put a **ring** around the correct sample number.

1 2 3 4 5 6 [1]

(ii) Suggest reasons why this test gave the wrong result.

.....

.....

.....

.....

.....

.....

.....

.....

.....

..... [4]

(b) All the test results for material X are reliable, but there are small differences between their values.

Why are these values different?

Put a tick (✓) in the box next to the correct answer.

Samples of X and Y had been mixed up.

Samples of X may vary.

It is not a fair test.

The steel point had not been pressed into the samples.

[1]

(c) Complete the table below to show the range of hardness number for material X.

	range
range for X to

[1]

[Total: 7]

5 Read this article.

There will be no more blue Smarties

The manufacturer is removing all artificial colours from Smarties. There is no natural alternative to the blue chemical used now.

The blue will be replaced by a white Smartie.

A recent study showed a possible harmful effect on the nervous system due to artificial colours and chemicals.

The blue colouring may cause hyperactivity and skin rashes. It is also listed as a cancer risk by the US Environmental Protection Agency.

A scientist said 'It is great news for children's health. We would now like to see the Government announce a total ban on the blue colouring.'



© iStockphoto.com / RA Photograph

(a) Why are blue Smarties no longer being made?

Put a tick (✓) in the box next to the **best** answer.

Eating a blue Smartie will give all children a rash.

All children who eat blue Smarties will develop health problems.

The blue colouring may make some children hyperactive.

All artificial additives will harm children.

[1]

(b) Why would the scientist like to see the Government ban the blue colour?

Put a tick (✓) in the box next to the **best** answer.

To stop blue Smarties from being made.

The blue colour is used in other foods.

So the risk can be measured.

To make Smarties cheaper.

To reduce the risk to children's health.

[1]

[Total: 2]

6 This is a question about farming.



(a) Here are five sentences explaining why a wheat field becomes less fertile each year. They are in the wrong order.

- A Wheat uses these nitrogen compounds to make proteins in the plant.
- B There are nitrogen compounds in water in the soil.
- C Wheat is harvested and taken from the field.
- D Wheat plants take in nitrogen compounds through their roots.
- E The concentration of nitrogen compounds in the soil falls.

Fill in the boxes to show the right order. The last one has been done for you.

				E
--	--	--	--	---

[3]

(b) Here are three statements about the advantages and disadvantages of intensive farming.

For each one write **A** if it is an advantage or **D** if it is a disadvantage.

statement	A (advantage) or D (disadvantage)
Food is cheaper.	
Less land is needed.	
Soil structure may be damaged.	

[2]

(c) The lists below show different organic farming methods and the reasons for their use.

Draw a straight line from each **method** to the correct **reason**.

One has been done for you.

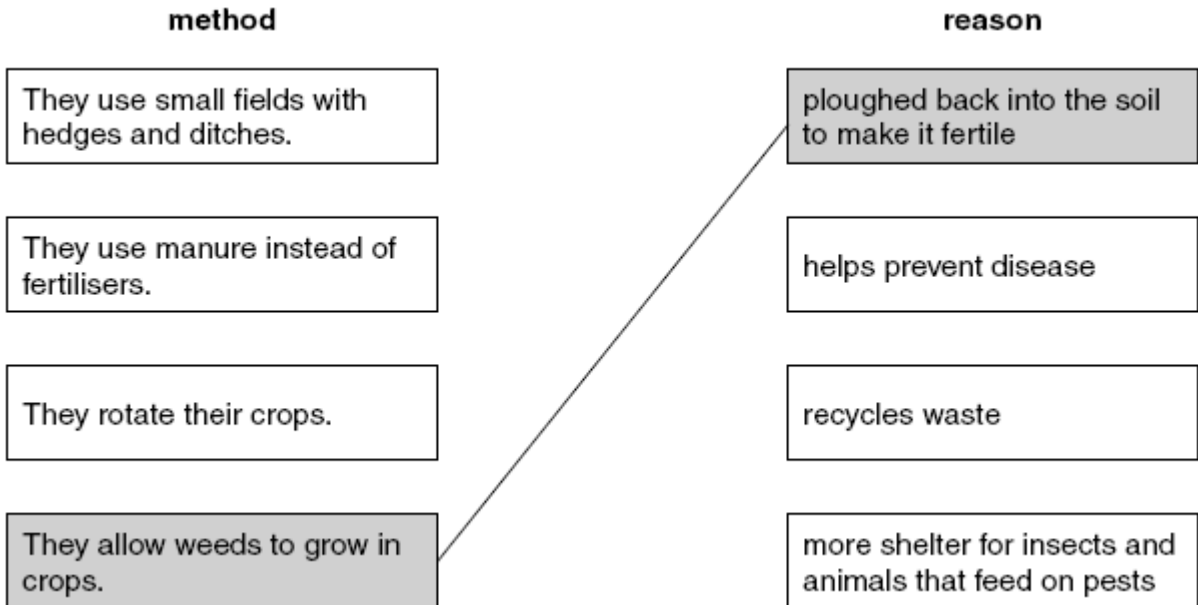

[2]

[Total: 7]

7 The Government is worried about the increase in childhood obesity.

The number of 2 to 11 year olds who are obese has risen steadily over the past 10 years.

Most obese children grow up to be obese adults.

The number of adults with type 2 diabetes is also rising.

(a) Suggest and explain how the increase in childhood obesity may affect the number of people who develop type 2 diabetes in their forties and fifties.

.....
.....
.....
..... [2]

(b) Politicians want to pass laws to help reduce childhood obesity.

Here are some actions they could take.

Which **two** actions may help reduce obesity?

Put ticks (✓) in the boxes next to the **two** correct answers.

- Banning salads from school lunches.
- Banning fizzy drinks machines from schools.
- Banning junk food advertising.
- Banning the sale of bottled water in schools.

[2]

[Total: 4]

END OF QUESTION PAPER

BLANK PAGE

PLEASE DO NOT WRITE ON THIS PAGE

Copyright Acknowledgements:

Q5 "Smarties" is a Registered Trademark of Société des Produits Nestlé S.A. Photograph © iStockphoto.com / RA Photography

Permission to reproduce items where third-party owned material protected by copyright is included has been sought and cleared where possible. Every reasonable effort has been made by the publisher (OCR) to trace copyright holders, but if any items requiring clearance have unwittingly been included, the publisher will be pleased to make amends at the earliest possible opportunity.

OCR is part of the Cambridge Assessment Group. Cambridge Assessment is the brand name of University of Cambridge Local Examinations Syndicate (UCLES), which is itself a department of the University of Cambridge.

The Periodic Table of the Elements

1 2 3 4 5 6 7 0

1 H hydrogen 1

4 He helium 2

Key
relative atomic mass
atomic symbol
name
atomic (proton) number

7 Li lithium 3	9 Be beryllium 4											11 B boron 5	12 C carbon 6	14 N nitrogen 7	16 O oxygen 8	19 F fluorine 9	20 Ne neon 10
23 Na sodium 11	24 Mg magnesium 12											27 Al aluminium 13	28 Si silicon 14	31 P phosphorus 15	32 S sulfur 16	35.5 Cl chlorine 17	40 Ar argon 18
39 K potassium 19	40 Ca calcium 20	45 Sc scandium 21	48 Ti titanium 22	51 V vanadium 23	52 Cr chromium 24	55 Mn manganese 25	56 Fe iron 26	59 Co cobalt 27	59 Ni nickel 28	63.5 Cu copper 29	65 Zn zinc 30	70 Ga gallium 31	73 Ge germanium 32	75 As arsenic 33	79 Se selenium 34	80 Br bromine 35	84 Kr krypton 36
85 Rb rubidium 37	88 Sr strontium 38	89 Y yttrium 39	91 Zr zirconium 40	93 Nb niobium 41	96 Mo molybdenum 42	[98] Tc technetium 43	101 Ru ruthenium 44	103 Rh rhodium 45	106 Pd palladium 46	108 Ag silver 47	112 Cd cadmium 48	115 In indium 49	119 Sn tin 50	122 Sb antimony 51	128 Te tellurium 52	127 I iodine 53	131 Xe xenon 54
133 Cs caesium 55	137 Ba barium 56	139 La* lanthanum 57	178 Hf hafnium 72	181 Ta tantalum 73	184 W tungsten 74	186 Re rhenium 75	190 Os osmium 76	192 Ir iridium 77	195 Pt platinum 78	197 Au gold 79	201 Hg mercury 80	204 Tl thallium 81	207 Pb lead 82	209 Bi bismuth 83	[209] Po polonium 84	[210] At astatine 85	[222] Rn radon 86
[223] Fr francium 87	[226] Ra radium 88	[227] Ac* actinium 89	[261] Rf rutherfordium 104	[262] Db dubnium 105	[266] Sg seaborgium 106	[264] Bh bohrium 107	[277] Hs hassium 108	[268] Mt meitnerium 109	[271] Ds darmstadtium 110	[272] Rg roentgenium m 111	Elements with atomic numbers 112-116 have been reported but not fully authenticated						

* The lanthanoids (atomic numbers 58-71) and the actinoids (atomic numbers 90-103) have been omitted.

The relative atomic masses of copper and chlorine have not been rounded to the nearest whole number

A321/01



CONFIDENTIAL

GCSE Unit

MARK SCHEME

SAMPLE ASSESSMENT MATERIAL
(from 2010 onwards)

Chemistry A (J634)
Modules C1, C2 and C3
Foundation Tier

A321/01

Maximum Mark: 42

Guidance for Examiners

Additional Guidance within any mark scheme takes precedence over the following guidance.

1. Mark strictly to the mark scheme.
2. Make no deductions for wrong work after an acceptable answer unless the mark scheme says otherwise.
3. Accept any clear, unambiguous response which is correct, e.g. mis-spellings if phonetically correct (but check additional guidance).
4. Abbreviations, annotations and conventions used in the detailed mark scheme:

/	= alternative and acceptable answers for the same marking point
(1)	= separates marking points
not/reject	= answers which are not worthy of credit
ignore	= statements which are irrelevant - applies to neutral answers
allow/accept	= answers that can be accepted
(words)	= words which are not essential to gain credit
<u>words</u>	= underlined words must be present in answer to score a mark
ecf	= error carried forward
AW/owtte	= alternative wording
ORA	= or reverse argument

E.g. mark scheme shows 'work done in lifting / (change in) gravitational potential energy' (1)

work done = 0 marks

work done lifting = 1 mark

change in potential energy = 0 marks

gravitational potential energy = 1 mark

5. If a candidate alters his/her response, examiners should accept the alteration.
6. Crossed out answers should be considered only if no other response has been made. When marking crossed out responses, accept correct answers which are clear and unambiguous.
7. The list principle:
If a list of responses greater than the number requested is given, work through the list from the beginning. Award one mark for each correct response, ignore any neutral response, and deduct one mark for any incorrect response, e.g. one which has an error of science. If the number of incorrect responses is equal to or greater than the number of correct responses, no marks are awarded. A neutral response is correct but irrelevant to the question.

A321/01

8. Marking method for tick boxes:

Always check the additional guidance.

If there is a set of boxes, some of which should be ticked and others left empty, then judge the entire set of boxes.

If there is at least one tick, ignore crosses. If there are no ticks, accept clear, unambiguous indications, e.g. shading or crosses.



Credit should be given for each box correctly ticked. If more boxes are ticked than there are correct answers, then deduct one mark for each additional tick. Candidates cannot score less than zero marks.

E.g. If a question requires candidates to identify a city in England, then in the boxes

Edinburgh	
Manchester	
Paris	
Southampton	

the second and fourth boxes should have ticks (or other clear indication of choice) and the first and third should be blank (or have indication of choice crossed out).

Edinburgh			✓			✓	✓	✓	✓	
Manchester	✓	x	✓	✓	✓				✓	
Paris				✓	✓		✓	✓	✓	
Southampton	✓	x		✓		✓	✓		✓	
Score:	2	2	1	1	1	1	0	0	0	NR

Question		Expected Answers	Marks	Rationale																
1	a	more people will travel in each car (1) fewer cars will be needed (1) less exhaust gas will pollute the air (1)	3																	
	b	all of them (1)	1	any clear indication of all of them as their choice																
	c	<table border="1"> <thead> <tr> <th></th> <th>decreases</th> <th>increases</th> <th>same</th> </tr> </thead> <tbody> <tr> <td>carbon dioxide</td> <td></td> <td>✓</td> <td></td> </tr> <tr> <td>carbon monoxide</td> <td>✓</td> <td></td> <td></td> </tr> <tr> <td>nitrogen oxides</td> <td>✓</td> <td></td> <td></td> </tr> </tbody> </table>		decreases	increases	same	carbon dioxide		✓		carbon monoxide	✓			nitrogen oxides	✓			2	<p>Carbon dioxide increases = 1 mark More than one tick on the row = 0 marks</p> <p>Carbon monoxide and nitrogen oxides decreases = 1 mark Tick in any other box on these two rows = 0marks</p>
	decreases	increases	same																	
carbon dioxide		✓																		
carbon monoxide	✓																			
nitrogen oxides	✓																			
	d i	hydrocarbons (1)	1	Give mark if 'hydrocarbons' indicated in the word list by a ring, line or some other method																
	ii		1	<p>Carbon MUST touch two oxygen circles and circles must be in correct order</p> <p>For carbon dioxide there must be one black circle in the middle of two white circles. Need not be linear but the two circles representing oxygen atoms must NOT touch.</p> <p>Allow letters in circles with no shading necessary </p> <p>Allow lines connecting circles like this: </p>																
Total			8																	

Question		Expected Answers	Marks	Rationale					
2	a	next to the power station less than 500 metres from station	<table border="1" style="display: inline-table; vertical-align: middle;"> <tr><td style="text-align: center;">✓</td></tr> <tr><td style="text-align: center;">✓</td></tr> <tr><td style="text-align: center;"> </td></tr> <tr><td style="text-align: center;"> </td></tr> </table> (1) (1)	✓	✓			2	One mark for each correct answer. If three boxes ticked mark these responses and deduct one mark. If four boxes ticked 0 marks
✓									
✓									
	b	i	Dina (1)	1	More than one response = 0marks				
		ii	Josh (1) Hannah (1)	2	One mark for each correct answer in EITHER order. If three names given mark answers and deduct 1 mark. 4 names given = 0				
		iii	Hannah (1)	1	More than one response = 0marks				
Total			6						

Question		Expected Answers	Marks	Rationale					
3	a	density is lower (1) so less difficult to move (1) cost is lower (1) so rocking horse will be lower price / easier to sell (1)	4						
	b	<table border="1" style="display: inline-table; vertical-align: middle;"> <tr><td style="text-align: center;"> </td></tr> <tr><td style="text-align: center;"> </td></tr> <tr><td style="text-align: center;"> </td></tr> <tr><td style="text-align: center;"> </td></tr> <tr><td style="text-align: center;">✓</td></tr> </table> (1)					✓	1	A tick in any other box = 0 marks
✓									
	c	landfill rot burned recycled	3	4 correct (3) 3 correct (2) 2 or 1 correct (1)					
Total			8						

Question			Expected Answers	Marks	Rationale				
4	a	i	4 (1)	1					
		ii	a larger force was used on the steel point (1) this sample of material Y was different to the others (1) the machine developed a fault (1) the scientist made a mistake (1) samples of X and Y had been mixed up (1)	4	any four				
	b		samples of X may vary <table border="1" style="display: inline-table; vertical-align: middle;"><tr><td> </td></tr><tr><td>✓</td></tr><tr><td> </td></tr><tr><td> </td></tr></table> (1)		✓			1	A tick in any other box = 0 marks
✓									
	c		7-12 (1)	1	Allow 12 -7. Allow 5 or 6 or 12-7=5				
Total				7					

Question			Expected Answers	Marks	Rationale										
5	a		may make children hyperactive <table border="1" style="display: inline-table; vertical-align: middle;"><tr><td> </td></tr><tr><td>✓</td></tr><tr><td> </td></tr></table> (1)		✓		1	A tick in any other box = 0 marks							
✓															
	b		reduce risk to children's health <table border="1" style="display: inline-table; vertical-align: middle;"><tr><td> </td></tr><tr><td> </td></tr><tr><td> </td></tr><tr><td> </td></tr><tr><td> </td></tr><tr><td> </td></tr><tr><td> </td></tr><tr><td> </td></tr><tr><td> </td></tr><tr><td> </td></tr></table> (1)											1	A tick in any other box = 0 marks
Total				2											

Question		Expected Answers	Marks	Rationale								
6	a	<table border="1" style="display: inline-table; vertical-align: top;"> <tr> <td>B</td> <td>D</td> <td>A</td> <td>C</td> <td>(E)</td> </tr> </table> <p>B before D (1) D before A (1) A before C (1)</p>	B	D	A	C	(E)	3	B before D (1 mark); D before A (1 mark); A before C (1 mark); If any letter is used twice. Ignore the second.			
B	D	A	C	(E)								
	b	<p>food is cheaper less land is needed soil structure may be damaged</p> <table border="1" style="display: inline-table; vertical-align: top;"> <tr><td>A</td></tr> <tr><td>A</td></tr> <tr><td>D</td></tr> </table>	A	A	D	2	All three correct = 2 marks Two or one correct = 1 mark					
A												
A												
D												
	c	<table border="1" style="width: 100%; border-collapse: collapse;"> <tr> <td style="width: 50%; padding: 5px;">small fields with hedges and ditches</td> <td style="width: 50%; padding: 5px;"></td> </tr> <tr> <td style="padding: 5px;">manure instead of fertilizer</td> <td style="padding: 5px;">helps prevent disease</td> </tr> <tr> <td style="padding: 5px;">rotate their crops</td> <td style="padding: 5px;">recycles waste</td> </tr> <tr> <td style="padding: 5px;"></td> <td style="padding: 5px;">more shelter</td> </tr> </table>	small fields with hedges and ditches		manure instead of fertilizer	helps prevent disease	rotate their crops	recycles waste		more shelter	2	Look at the links as they leave the left-hand boxes. If any left-hand box has more than one link, count those links as incorrect. All three lines correct = 2 marks Two or one line correct = 1 mark
small fields with hedges and ditches												
manure instead of fertilizer	helps prevent disease											
rotate their crops	recycles waste											
	more shelter											
Total			7									

Question		Expected Answers	Marks	Rationale
7	a	more obese children will result in more obese people in their 40s and 50s (1) obesity is a risk factor in developing type 2 diabetes (1)	2	
	b	banning fizzy drink machines <input type="checkbox"/> <input checked="" type="checkbox"/> (1) banning junk food advertising <input checked="" type="checkbox"/> <input type="checkbox"/> (1)	2	One mark for each correct answer. If three boxes ticked mark these responses and deduct one mark. If four boxes ticked 0 marks
		Total	4	
		Section total	42	