

Centre Number						Candidate Number				
Surname										
Other Names										
Candidate Signature										

For Examiner's Use	
Examiner's Initials	
Question	Mark
1	
2	
3	
4	
5	
6	
7	
TOTAL	



General Certificate of Secondary Education  
Higher Tier  
June 2010

## Additional Science

Unit Biology B2

**BLY2H**

## Biology

Unit Biology B2

**H**

### Written Paper

**Friday 21 May 2010 9.00 am to 9.45 am**

**You will need no other materials.**  
You may use a calculator.

#### Time allowed

- 45 minutes

#### Instructions

- Use black ink or black ball-point pen.
- Fill in the boxes at the top of this page.
- Answer **all** questions.
- You must answer the questions in the spaces provided. Do not write outside the box around each page or on blank pages.
- Do all rough work in this book. Cross through any work you do not want to be marked.

#### Information

- The marks for questions are shown in brackets.
- The maximum mark for this paper is 45.
- You are expected to use a calculator where appropriate.
- You are reminded of the need for good English and clear presentation in your answers.

#### Advice

- In all calculations, show clearly how you work out your answer.



J U N 1 0 B L Y 2 H 0 1

Answer **all** questions in the spaces provided.

**1** This question is about photosynthesis.

**1 (a)** Plants make glucose during photosynthesis. Some of the glucose is changed into insoluble starch.

What happens to this starch?

Tick (✓) **one** box.

The starch is converted into oxygen.

The starch is stored for later use.

The starch is used to make the leaf green.

(1 mark)

**1 (b)** A student investigated the effect of temperature on the rate of photosynthesis in pondweed.

The diagram shows the way the experiment was set up.

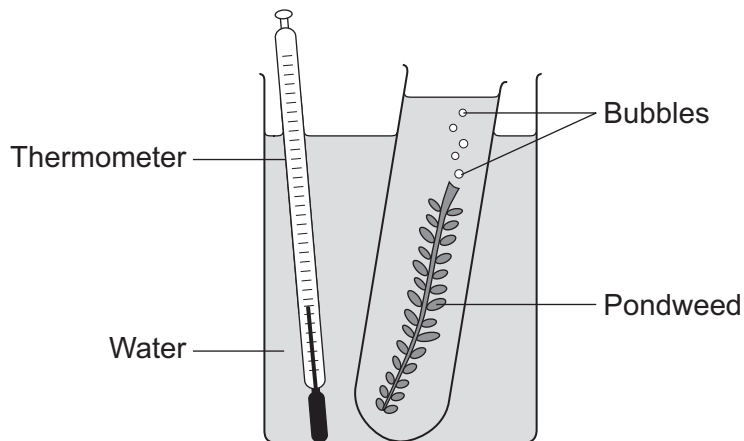

**1 (b) (i)** The student needed to control some variables to make the investigation fair.

State **two** of these variables.

1 .....

2 .....

(2 marks)



1 (b) (ii) The bubbles of gas are produced only while photosynthesis is taking place.

What **two** measurements would the student make to calculate the rate of photosynthesis?

1 .....

2 .....

(2 marks)

1 (c) The graph shows the effect of temperature on the rate of photosynthesis.

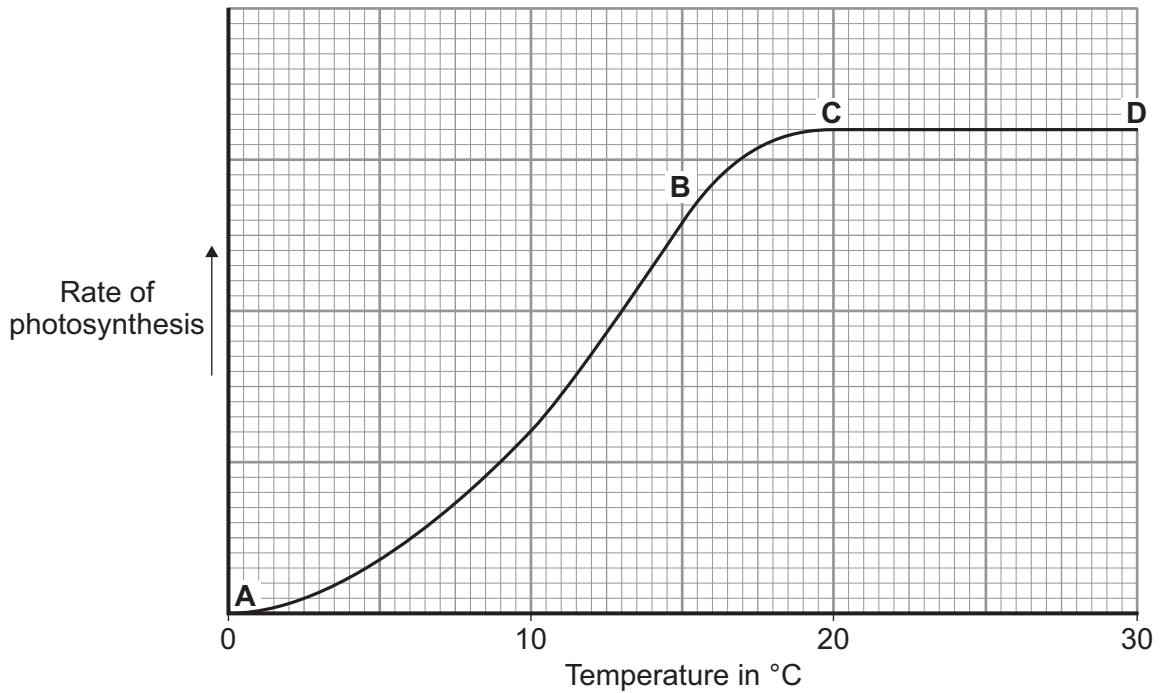

1 (c) (i) Name the factor that limits the rate of photosynthesis between the points labelled **A** and **B** on the graph.

.....  
(1 mark)

1 (c) (ii) Suggest which factor, carbon dioxide, oxygen or water, might limit the rate of photosynthesis between the points labelled **C** and **D** on the graph.

.....  
(1 mark)

7
---

Turn over ►



2 (a) **Diagram 1** represents what happens to the energy in the food eaten by a herbivore (an animal that eats plants).

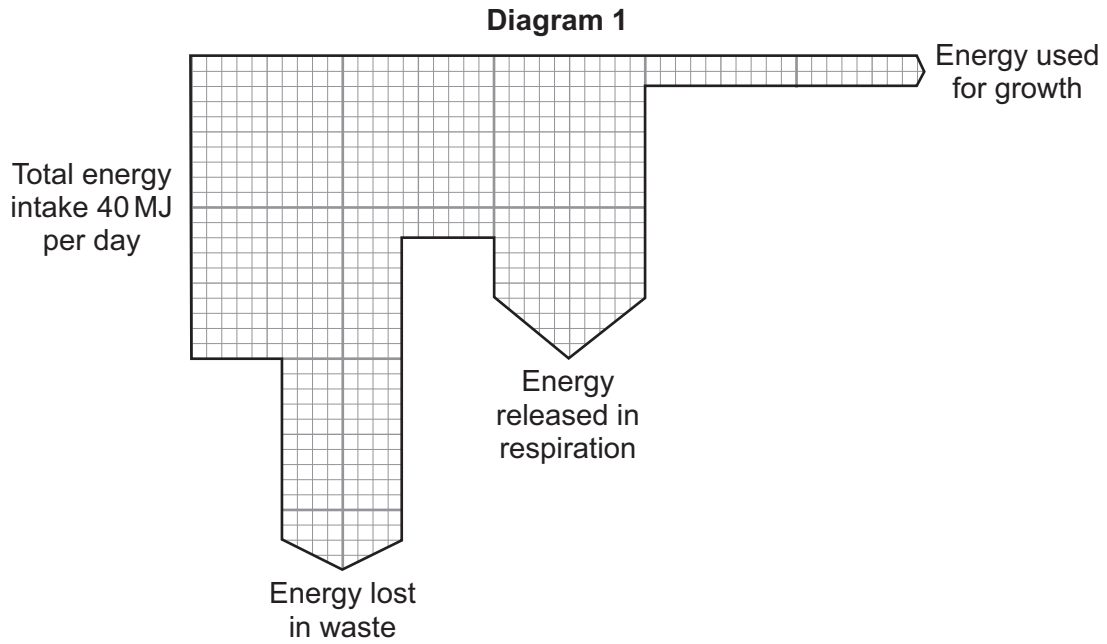

2 (a) (i) How much energy is released in respiration by the herbivore?

.....  
 .....

Answer ..... MJ per day  
 (1 mark)

2 (a) (ii) What proportion of the total energy intake of the herbivore is used for growth?

Show clearly how you work out your answer.

.....  
 .....

Proportion .....  
 (2 marks)

2 (b) Give **two** ways in which the energy, released in respiration, is used by a herbivore.

1 .....  
 2 .....

(2 marks)



2 (c) **Diagram 2** represents what happens to the energy in the food eaten by a carnivore (an animal that eats other animals).

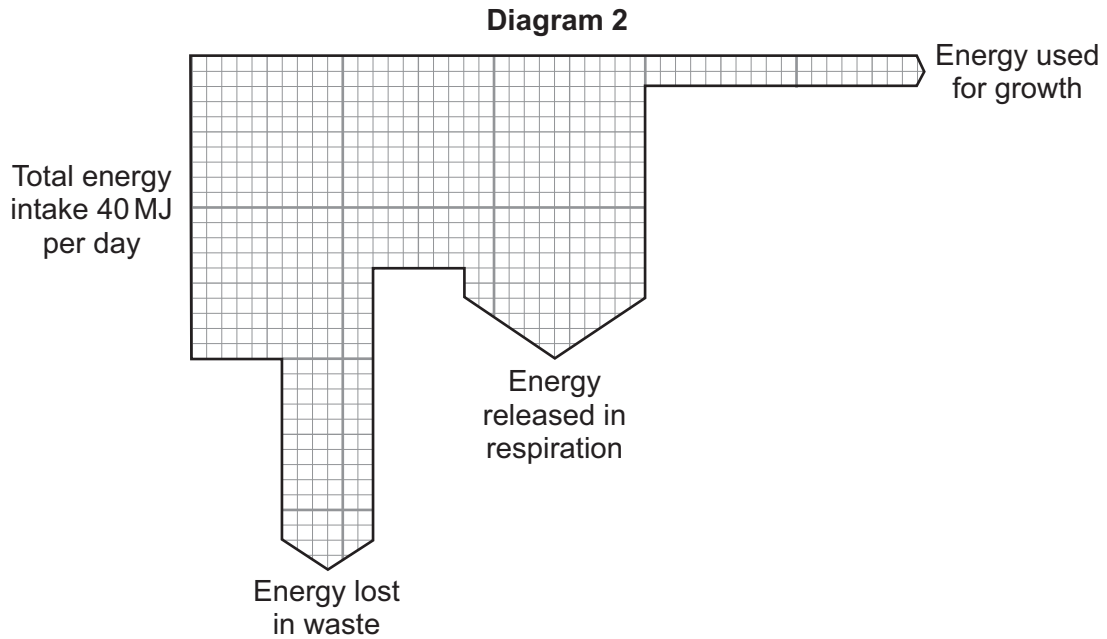

The carnivore releases a greater proportion of energy in respiration than the herbivore.

Suggest **one** reason for this.

.....  
 .....  
 (1 mark)

2 (d) Some farmers keep their animals outdoors. Other farmers keep their animals indoors.

Keeping farm animals indoors increases the proportion of energy in their food that is converted into growth.

Give **two** reasons why.

1 .....

.....

2 .....

.....  
 (2 marks)

8

Turn over ►



3 The diagram shows part of the carbon cycle.

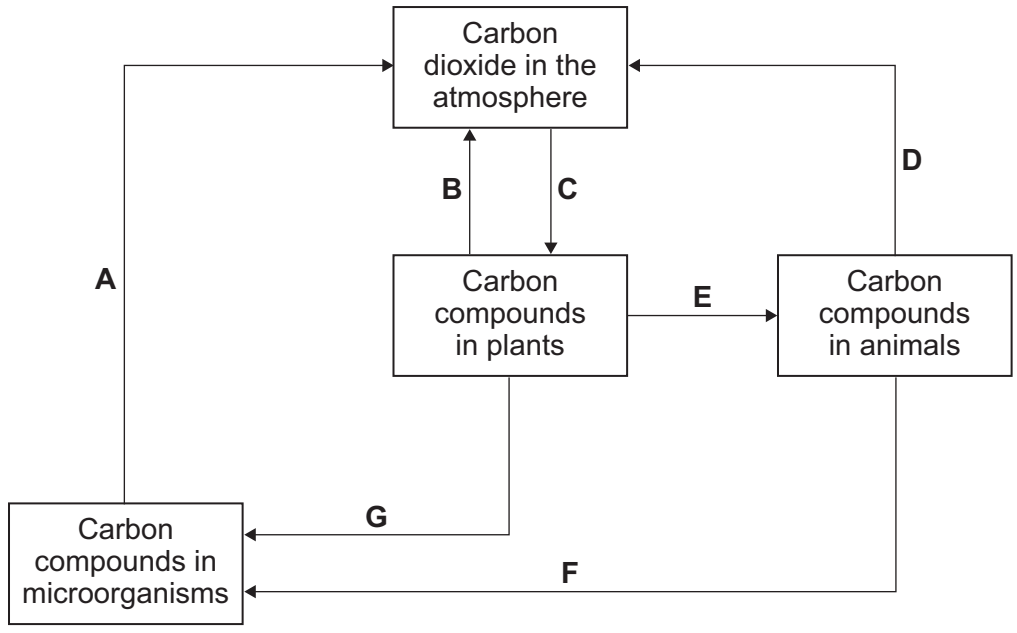

3 (a) Letter **A** represents respiration.

Which **two** other letters represent respiration?

and

(1 mark)

3 (b) Other than carbon dioxide name **two** carbon compounds found in plants.

1 .....

2 .....

(2 marks)



**3 (c)** Gardeners use compost heaps to decay dead plants. Decayed compost is then spread onto the soil in a garden.

Explain why gardeners spread decayed compost onto the soil.

.....

.....

.....

.....

(2 marks)

5
---

**Turn over for the next question**

**Turn over ►**



**There are no questions printed on this page**

**DO NOT WRITE ON THIS PAGE  
ANSWER IN THE SPACES PROVIDED**





4 Diagrams **A**, **B** and **C** show cells from different parts of the human body, all drawn to the same scale.

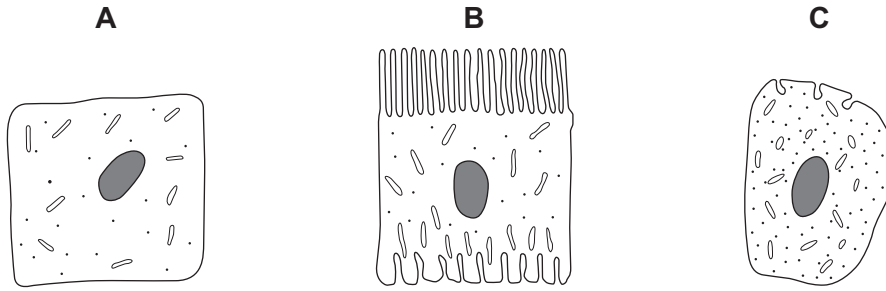

**Key**

- Mitochondrion
- Ribosome

4 (a) Which cell, **A**, **B** or **C**, appears to have adaptations to increase diffusion into or out of the cell?

Give **one** reason for your choice.

.....  
 .....  
(1 mark)

4 (b) (i) Cell **C** is found in the pancreas.

Name **one** useful substance produced by the pancreas.

.....  
(1 mark)

4 (b) (ii) Use information from the diagram to explain how cell **C** is adapted for producing this substance.

.....  
 .....  
 .....  
 .....  
(2 marks)

4

Turn over ►



5 Conditions inside the body must be kept constant.

5 (a) Urea must be removed from the body.

5 (a) (i) Name the organ which makes urea.

.....  
(1 mark)

5 (a) (ii) Which organ removes urea from the body?

.....  
(1 mark)

5 (a) (iii) What is urea made from?

.....  
(1 mark)

A man sat in a room where the temperature was maintained at 40 °C.  
The temperature on the surface of his skin was monitored for 35 minutes.  
He swallowed an ice cold drink at the time indicated on the graph.

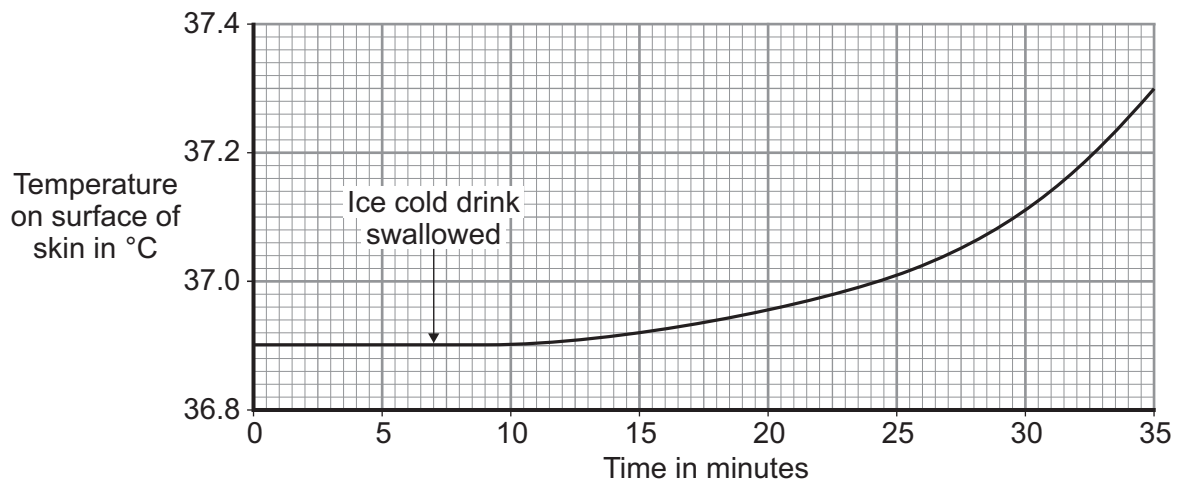

**5 (b)** The sweat glands contribute to the change in the temperature on the surface of the skin shown on the graph.

Explain how.

.....

.....

.....

.....

.....

.....

(2 marks)

**5 (c)** The blood vessels near the surface of the skin also contribute to the changes in skin temperature shown on the graph.

**5 (c) (i)** How do the blood vessels in the skin change when the core body temperature falls?

.....

.....

(1 mark)

**5 (c) (ii)** How does this change in the blood vessels explain the change in the skin temperature shown on the graph?

.....

.....

(1 mark)

<b>7</b>

**Turn over for the next question**

**Turn over ►**



**6** Fresh milk is a mixture of compounds including fat, protein and about 5% lactose sugar. Lactose must be digested by the enzyme lactase, before the products can be absorbed.

Lactase can be added to fresh milk to pre-digest the lactose. This makes 'lactose-free' milk, which is suitable for people who do not produce enough lactase of their own.

A student investigated the effect of changing pH and temperature on the digestion of lactose in milk.

The results are shown in **Tables 1** and **2**.

**Table 1**  
Effect of pH

pH	Time taken to digest lactose in minutes
4.0	20
5.0	18
6.0	13
7.0	7
8.0	5
9.0	6

**Table 2**  
Effect of temperature

Temperature in °C	Time taken to digest lactose in minutes
30	20
35	14
40	11
45	6
50	12
55	23

**6 (a)** The label on a carton of lactose-free milk states:

'Lactase is normally produced in the stomach of mammals.'

The results in **Table 1** show that this statement is unlikely to be true.

Explain how.

.....

.....

.....

.....

(2 marks)



**6 (b)** Explain as fully as you can the results shown in **Table 2**.

.....

.....

.....

.....

.....

.....

.....

(3 marks)

**6 (c)** Bile is produced in the liver and is released into the small intestine.

Explain how bile helps the digestion of milk.

.....

.....

.....

.....

(2 marks)

7

**Turn over for the next question**

**Turn over ►**



**7** The table shows the number of chromosomes found in each body cell of some different organisms.

Animals		Plants	
Species	Number of chromosomes in each body cell	Species	Number of chromosomes in each body cell
Fruit fly	8	Tomato	24
Goat	60	Potato	44
Human	46	Rice	24

**7 (a)** Nearly every organism on earth has an even number of chromosomes in its body cells. Suggest why.

.....  
 .....

(1 mark)

**7 (b)** Chromosomes contain DNA molecules. Describe the function of DNA.

.....  
 .....  
 .....  
 .....

(2 marks)



7 (c) Gametes are made in the testes by meiosis.

7 (c) (i) Look at the diagrams.

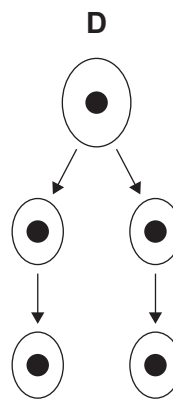
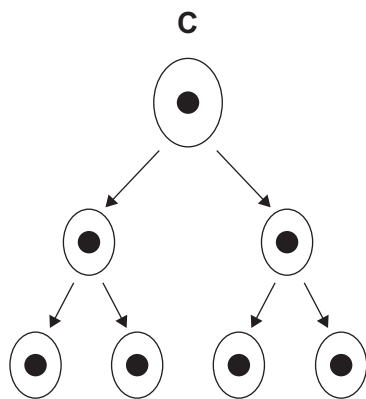
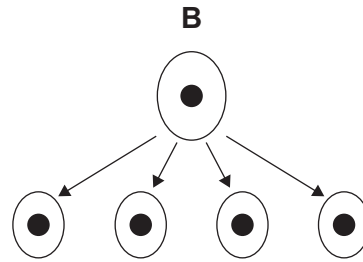
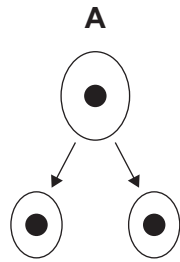

Which diagram, **A**, **B**, **C** or **D**, represents how cell division by meiosis produces gametes in the testes?

(1 mark)

7 (c) (ii) How many chromosomes will each goat gamete contain?

.....

(1 mark)

Question 7 continues on the next page

Turn over ►



**7 (d)** Body cells divide by mitosis.

**7 (d) (i)** Why is the ability of body cells to divide important?

.....  
.....

(1 mark)

**7 (d) (ii)** When a body cell of a potato plant divides, how many chromosomes will each of the new cells contain?

.....

(1 mark)

7

**END OF QUESTIONS**

