

Candidate Forename		Candidate Surname	
-------------------------------	--	------------------------------	--

Centre Number						Candidate Number				
--------------------------	--	--	--	--	--	-----------------------------	--	--	--	--

**OXFORD CAMBRIDGE AND RSA EXAMINATIONS
GENERAL CERTIFICATE OF SECONDARY EDUCATION**

**J649
B482/02**

APPLIED SCIENCE: DOUBLE AWARD

**UNIT 2: Science for the needs of society
(Higher Tier)**

**MONDAY 18 JANUARY 2010: Morning
DURATION: 1 hour**

SUITABLE FOR VISUALLY IMPAIRED CANDIDATES

Candidates answer on the Question Paper

A calculator may be used for this paper

OCR SUPPLIED MATERIALS:

None

OTHER MATERIALS REQUIRED:

Pencil

Ruler (mm/cm)

READ INSTRUCTIONS OVERLEAF

INSTRUCTIONS TO CANDIDATES

- **Write your name clearly in capital letters, your Centre Number and Candidate Number in the boxes on the first page.**
- **Use black ink. Pencil may be used for graphs and diagrams only.**
- **Read each question carefully and make sure that you know what you have to do before starting your answer.**
- **Answer ALL the questions.**
- **Write your answer to each question in the space provided, however additional paper may be used if necessary.**

INFORMATION FOR CANDIDATES

- **The number of marks is given in brackets [] at the end of each question or part question.**
- **The total number of marks for this paper is 60.**
- **The marks allocated and the spaces provided are a good indication of the length of answers required.**

BLANK PAGE

Answer ALL the questions.

1 Ryan works for a brewery that makes beer.

He manages the fermentation process.

Opposite is a flow diagram of how the beer is made.

(a) (i) Write down TWO stages in the process that will result in enzyme action.

Stage _____

Stage _____ [2]

(ii) At which stage will fermentation take place?

Stage _____ [1]

(b) Write down the WORD equation for fermentation.

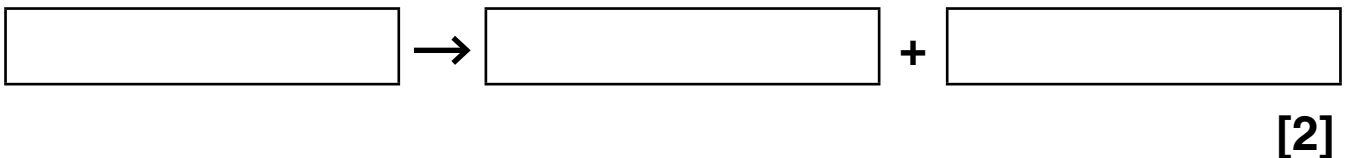

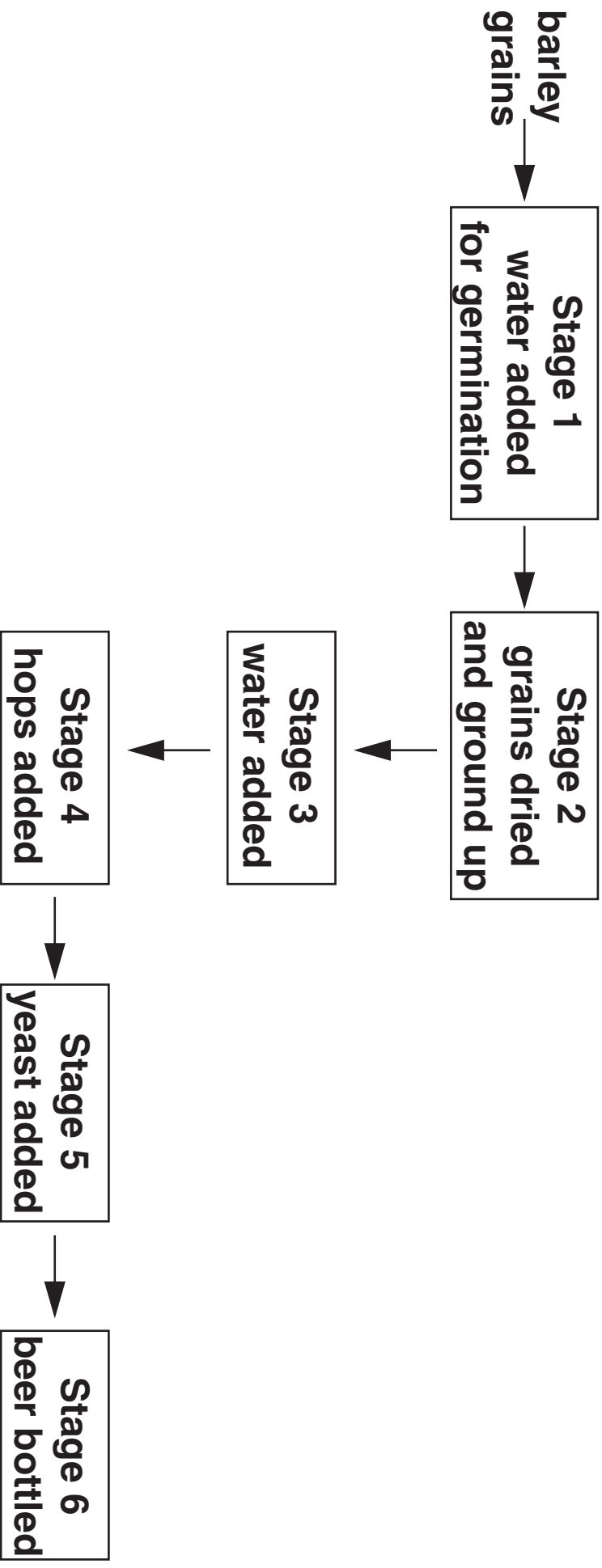

- (c) (i) For the fermentation to produce alcohol the yeast must respire ANAEROBICALLY.

What does ANAEROBIC mean?

_____ [1]

- (ii) Yeast can also respire AEROBICALLY.

What are the two products of AEROBIC respiration?

1. _____

2. _____ [2]

- (iii) What conditions are needed for yeast to carry out fermentation?

_____ [2]

- (d) Ryan is thinking of changing jobs.

His knowledge and experience of fermentation will be very useful in the manufacture of many products other than beer.

Suggest two products, other than alcoholic drinks, that are produced by fermentation.

1. _____

2. _____ [2]

[Total: 12]

2 Read the article about methane ice.

METHANE ICE: A CLIMATE SHOCK AHEAD?

Vast amounts of methane gas are trapped on the sea floor. According to scientists, the gas is far more likely to leak than they thought. The methane is trapped in ice crystals in the freezing waters of the deep sea at depths of over 300 m. Under these conditions the methane is kept under high pressure.

However, under some conditions, the methane gas can escape. This can happen if the methane ice is disturbed by Earth movements. The last big leak of methane was 44 000 years ago. The leak affected the climate and led to changes to the land. Scientists are worried the same problems might happen in the near future.

Methane is 10 times more powerful than carbon dioxide as a greenhouse gas. Scientists worry that as sea water warms, the methane could escape.

Hopes that the methane could be used as a fuel to ease the energy crisis have been rejected.

- (a) Suggest TWO reasons why the methane does not bubble to the surface.

[2]

(b) The methane leak 44 000 years ago affected the climate and led to changes to the land.

Describe the environmental problems that a large scale methane leak could cause.

[2]

(c) Methane is both an organic chemical and a fossil fuel.

Explain what the terms organic and fossil fuel mean.

organic _____

fossil fuel _____

[2]

(d) Methane ice is NOT found along boundaries between tectonic plates.

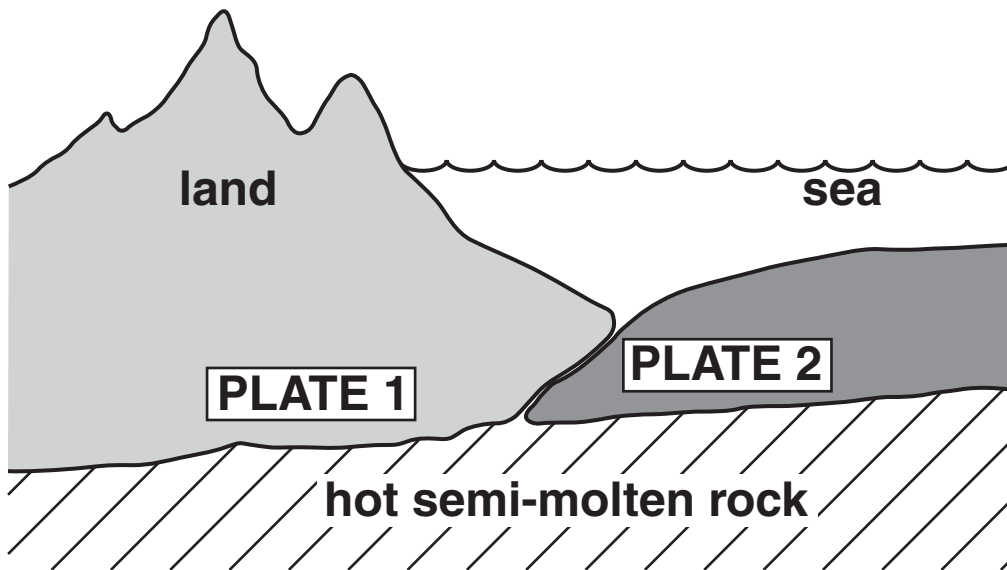

Which of the sentences give reasons why methane ice is not found at plate boundaries?

Put a tick (✓) in the boxes next to TWO correct answers.

Plate boundaries move against each other.

Plate boundaries are found along the edges of all continents.

Earthquakes and volcanoes occur in the middle of plates.

The rock around a plate boundary is often hot.

Not all plates are under the sea.

[2]

[Total: 8]

3 Joe is studying for his nursing exams. He is working on the circulatory system.

These are some of his revision questions.

(a) The circulatory system uses arteries, capillaries and veins to transport blood around the body.

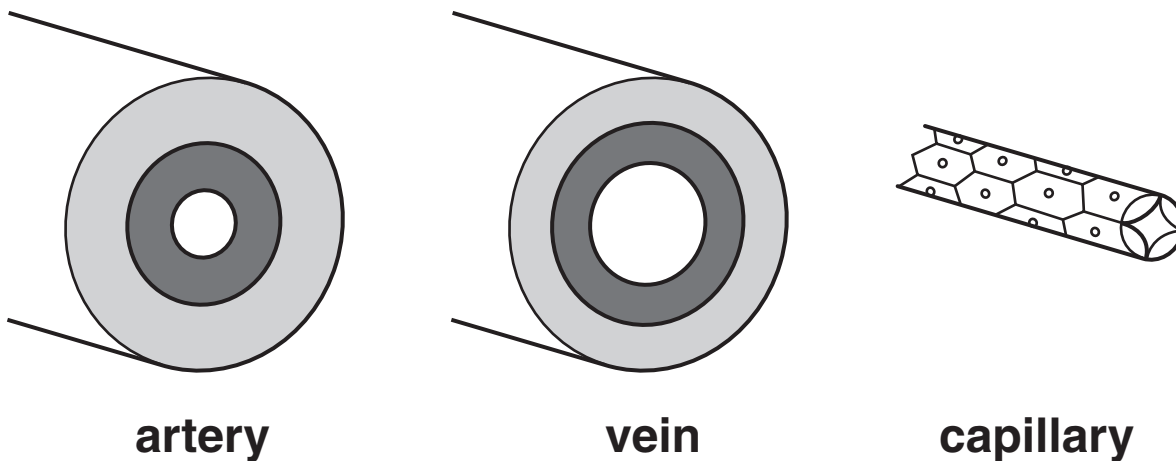

Each of the blood vessels is adapted to do a different job.

Complete the table about the types of blood vessel.

TYPE OF BLOOD VESSEL	JOB OF BLOOD VESSEL	ADAPTATIONS TO JOB
artery	carries blood under high pressure from heart	
vein		valves stop blood flowing backwards
capillary		

[4]

(b) The diagram shows the double circulatory system in humans.

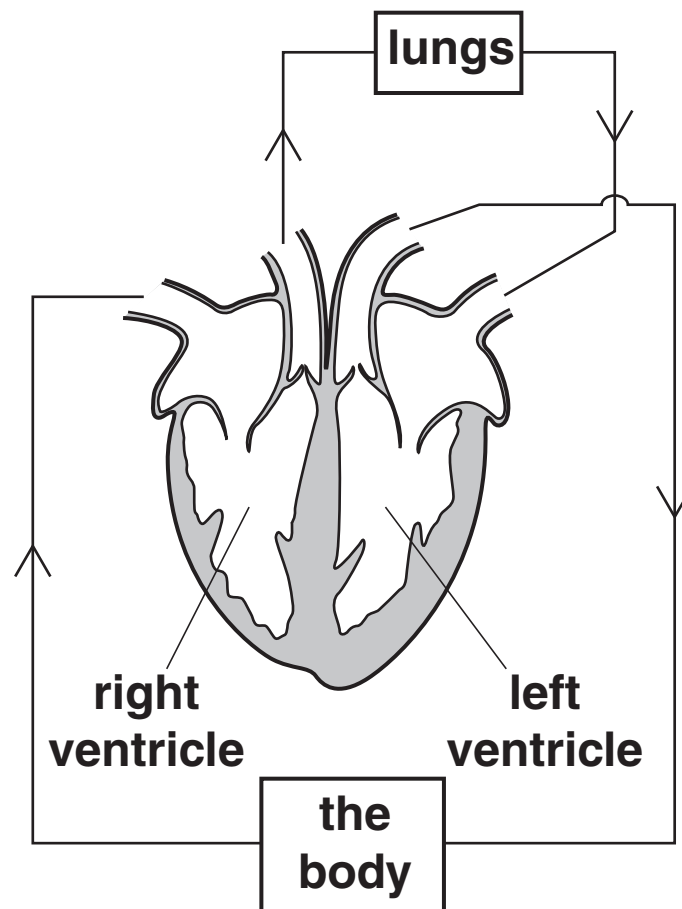

- (i) The heart pumps the blood around the two circuits using the muscles of the ventricle walls.**

Why is the muscle wall of the left ventricle thicker than the wall of the right ventricle?

[2]

(ii) Explain the advantage of a double circulatory system.

Use ideas about differences in pressure in your answer.

[2]

(c) Oxygen is carried in red blood cells by haemoglobin.

Write down the WORD equation for the reactions of oxygen with haemoglobin.

[2]

[Total: 10]

4 Liz is a garden designer.

She is going to make a large garden pond.

She draws a diagram to show the materials she will need to use.

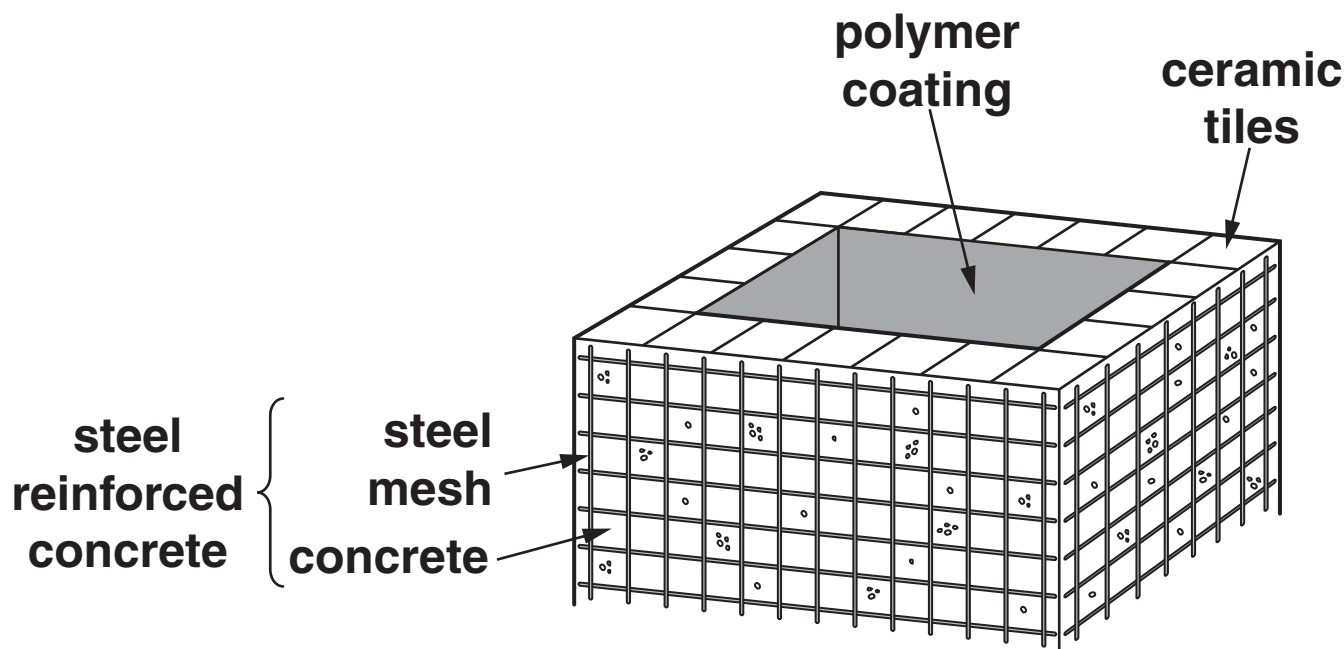

(a) From the diagram, give an example of

(i) A material that has been fired to form a cross linked structure.

_____ [1]

(ii) A composite material.

_____ [1]

(iii) A material containing atoms of Fe.

_____ [1]

(iv) The material most likely to contain organic molecules.

_____ [1]

(b) Liz buys a tin of ‘polymer coating’.

The tin contains the polymer dissolved in a solvent.

Liz brushes the mixture onto the pond walls.

The solvent turns into a gas and leaves the solid polymer coating behind.

(i) Which of the following words apply to this process?

Tick (✓) TWO boxes.

condensation

evaporation

reduction

suspension

emulsifier

solution

[2]

- (ii) The polymer coating contains plasticiser molecules.

Explain how these molecules change the properties of the polymer.

[3]

- (iii) Which of the following could be used as a plasticiser?

Put a **ring** around the correct answer.

BAKELITE

ENZYMES

ESTERS

MELAMINE

NYLON

[1]

[Total: 10]

BLANK PAGE

**5 Anita works at a coal fuelled power station.
It produces electricity for the National Grid.**

**(a) Complete the block diagram opposite showing
how the power station produces electricity.**

Choose words from this list.

BATTERY

BOILER

GENERATOR

PYLON

SOLAR PANEL

TURBINE

[3]

**(b) One of Anita's jobs is to monitor the electricity in
a part of the National Grid.**

(i) Why do we have a National Grid?

_____ **[1]**

**(ii) Part of the National Grid transfers 20 000W
using a voltage of 40 000V.**

Calculate the current.

You must show your working.

current = _____ Amps [2]

**(iii) Write down the relationship between power,
voltage and current.**

_____ **[1]**

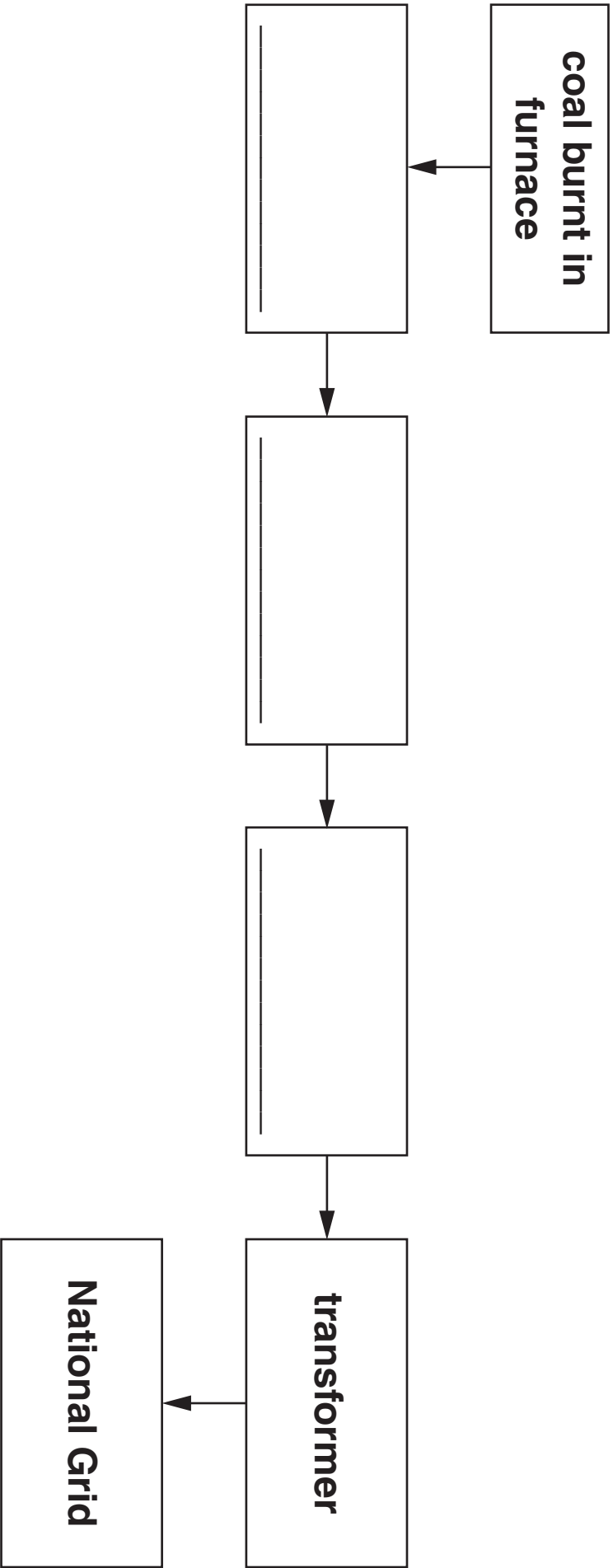

(c) Anita is not very happy working in a coal fired power station.

This is because coal is a non-renewable energy source that produces carbon dioxide.

(i) Explain what is meant by non-renewable energy source.

_____ [1]

(ii) A major disadvantage of using coal as fuel is that carbon dioxide is produced when it is burnt.

Give TWO advantages of using fossil fuels like coal.

_____ [2]

(d) Anita would rather work at a power station that is carbon neutral.

Which of the following are carbon dioxide neutral fuels?

Put a tick (✓) in the boxes next to the TWO correct answers.

biomass

coal

oil

natural gas

nuclear

[2]

[Total: 12]

6 Scientists are developing ways of disposing of waste polymers.

Two possible methods are shown in the diagram.

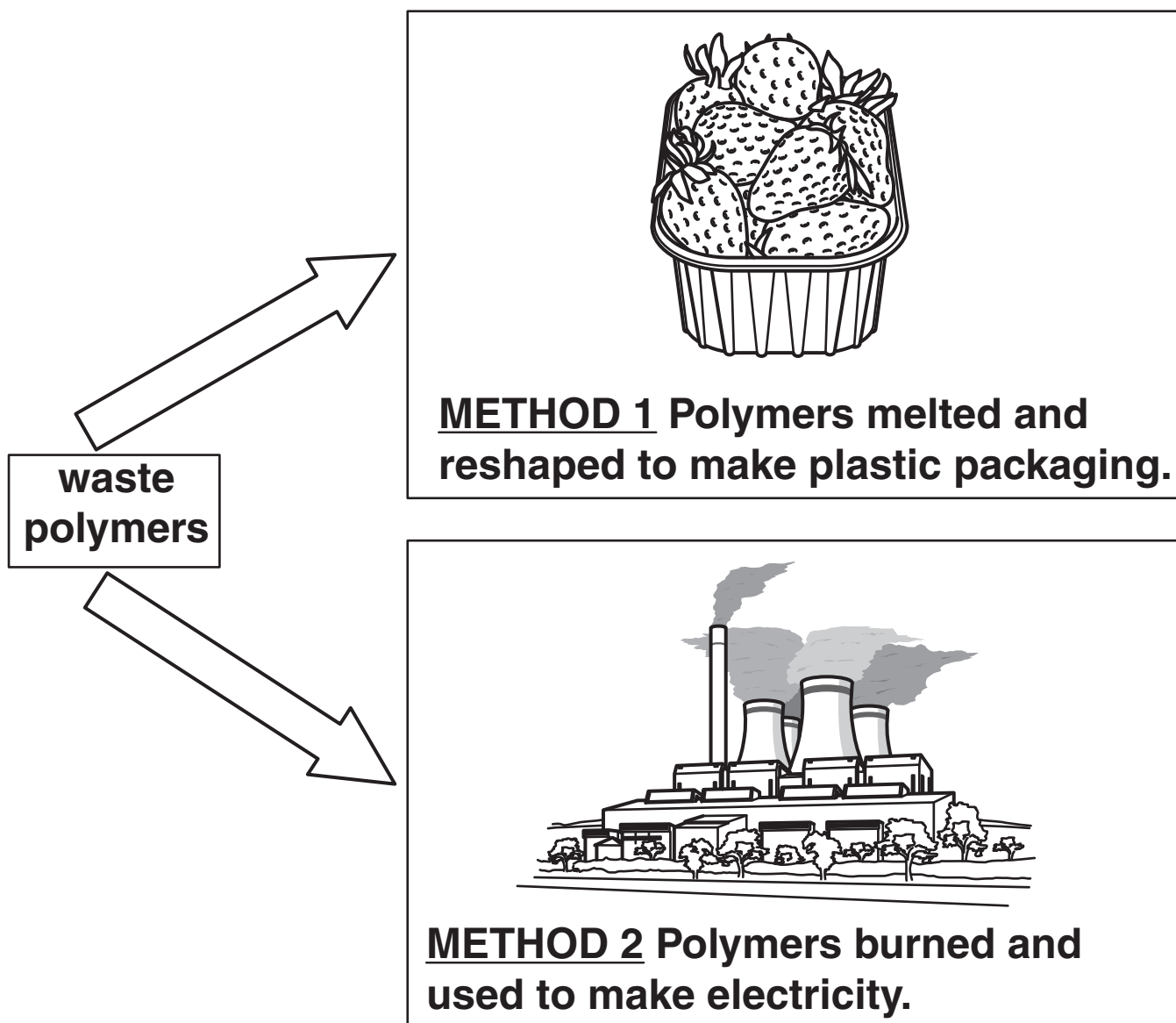

(a) Method 1 does not work for all types of polymer.

Explain why METHOD 1 works for some polymers and not for others.

Use ideas about forces between the chains of atoms.

[3]

(b) One disadvantage of METHOD 2 is that toxic hydrogen chloride gas is made.

(i) A hydrogen atom has one electron in its outer shell.

A chlorine atom has seven electrons in its outer shell.

Draw a dot and cross diagram to show the covalent bonding in a hydrogen chloride molecule.

[2]

- (ii) Hydrogen chloride can be made by burning hydrogen gas in chlorine gas.**

Write a balanced equation for this chemical reaction.

[3]

[Total: 8]

END OF QUESTION PAPER

BLANK PAGE

BLANK PAGE



Copyright Information

OCR is committed to seeking permission to reproduce all third-party content that it uses in its assessment materials. OCR has attempted to identify and contact all copyright holders whose work is used in this paper. To avoid the issue of disclosure of answer-related information to candidates, all copyright acknowledgements are reproduced in the OCR Copyright Acknowledgements Booklet. This is produced for each series of examinations, is given to all schools that receive assessment material and is freely available to download from our public website (www.ocr.org.uk) after the live examination series.

If OCR has unwittingly failed to correctly acknowledge or clear any third-party content in this assessment material, OCR will be happy to correct its mistake at the earliest possible opportunity.

For queries or further information please contact the Copyright Team, First Floor, 9 Hills Road, Cambridge CB2 1GE.

OCR is part of the Cambridge Assessment Group; Cambridge Assessment is the brand name of University of Cambridge Local Examinations Syndicate (UCLES), which is itself a department of the University of Cambridge.