

General Certificate of Secondary Education  
June 2008



**APPLIED ART AND DESIGN (DOUBLE AWARD) 3810/3/TN**  
**Unit 3 Working to project briefs**

**TEACHERS' NOTES**

**For immediate release to the teacher(s) responsible for GCSE Applied Art and Design (Double Award)**

All teacher-assessed marks to be returned to AQA by 31 May

**This document contains:**

- general guidance
- details of the Project Brief.

Time allowed: 10 hours

Preparatory period: 4 weeks

## Assessment

The mark awarded to a candidate must be seen to reflect accurately the assessment marking criteria for the unit. These are the only criteria that will be used to determine the mark awarded. It is important to ensure for consistency that no changes are made to the scenario, brief and instructions to candidates. Centres must avoid holistic marking that focuses only on the design proposal.

Candidates should be aware that information downloaded from the internet is of value only if it is clearly seen to have been used to develop ideas. Candidates should be encouraged to be selective and specific in the selection and use of source material and to ensure that it is relevant to the brief.

The distinctiveness of this award is in the vocational context of the work. Stress should be placed on the need for vocational importance in the methods of working, evaluation and presentation of the candidates' submissions. These qualities will inform the overall assessment. The following should be stressed to candidates:

- organisation of the research and development of ideas
- presentation of the developmental work and design proposal (N.B. annotation does not need to be word processed)
- quality of the evaluation.

## Time allocation and delivery

The brief should be given to candidates four school weeks before the first supervised session and the marks should be submitted to AQA by 31 May. The Project Brief has been written to include preparatory time and a total of 10 hours of supervised time for the production of the design proposal and evaluation. The first supervised session must be at least two hours and the work completed during the sessions must be kept under secure conditions between sessions.

By the end of the final supervised session, candidates must also have completed the evaluation of their response to the brief. The evaluation must be submitted together with the preparatory work and the design proposal at the end of the examination. It is suggested that candidates spend no more than 30 minutes of the 10 hours of supervised time on their written evaluation.

It is important that candidates are adequately prepared before undertaking the Project Brief. It is therefore expected that centres will have provided underpinning knowledge and guidance on how to work to a vocational project brief via similar activities as part of coursework. Candidates should have developed an awareness of how to:

- plan a response to the brief and undertake research, including the work of others
- select and use appropriate primary and secondary sources with media, materials and techniques
- develop and record different ideas, select one, make refinements and complete a design proposal
- present the design proposal effectively
- evaluate their response to the brief.

For further guidance on this unit refer to the unit specification and the assessment marking criteria.

---

**The following sections are reproduced from the Candidate Guidance document.**

### **What you have to do**

Read the scenario and select **one** of the briefs. Carry out research, paying particular attention to the constraints and considerations of your chosen brief, including project management and health and safety issues. You should also research the ways in which other artists, craftspeople and/or designers have provided solutions to similar briefs. The preparatory work should be included in your submission. You should submit the equivalent of not less than two, and not more than four, A1 sheets (or a sketchbook or other suitable form) of research and developmental work.

During the four week preparatory period you must research the brief by collecting information and making notes and sketches from a range of primary and secondary sources. This will form the basis of your development of ideas. You should also research and experiment with an appropriate range of different media, materials and techniques to develop alternative design solutions. These initial designs should be in the form of clear annotated records, which you will use as a resource during the 10 hours of supervised time to develop and refine **one** idea.

There are three distinct stages in the work you must do which link together to produce all the evidence required. Each stage has its own distinctive features but forms part of the whole. They are:

- research, including others' work and your own developmental work to meet the brief
- your design proposal, appropriately presented
- a short written evaluation of your design proposal.

The work that you present must be of a standard and scale suitable to present to clients at the point where the client agrees to accept the design proposal and agrees the work to progress to its final finished piece. A final finished piece to scale is **not** required.

For further guidance you should refer to the unit specification and the assessment marking criteria on page 6 of this guidance.

### **Introduction**

A scenario and five briefs are provided. You should select **one** brief and undertake research related to its requirements. The theme is a maritime museum roadshow; *Sea, stars and time*. Your research must include reference to work produced by others, with relevant primary and secondary research being included as part of your investigation. You should experiment with media and techniques to develop your ideas and progress to a design proposal that you will present to the client. Your work should take note of the relevant constraints identified in the brief you have selected and take into account the methods that would be used to produce the final piece of work if the client selects your design proposal.

**Turn over ►**

## The Project Brief

### Scenario

The directors of a maritime museum plan to produce an educational road show to promote various aspects of the collection. The title of the road show is *Sea, stars and time* and it will run from 2008–2009.

The road show collections include:

Seafaring  
Navigation  
Astronomy  
Time measurement.

The directors are offering a series of commissions to artists, craftspeople and designers to ensure the success of the road show.

Choose **one** of the following briefs.

### Briefs

- 1 Design a maritime painting for use as an illustration for a poster to promote the road show. Your design proposal must use colour to reflect a mood or feeling. The poster is to be landscape format and the size is:

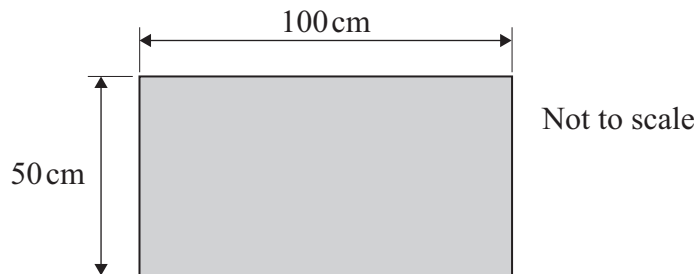

- 2 Design a sculpture based on time measurement. The sculpture must be transportable and suitable for the road show. Consideration must be given to the scale, form and choice of materials. Your intended dimensions for the finished sculpture must be included in the design proposal.
- 3 Design a commemorative 3D artefact for sale during the road show. It should be inspired by astronomy, and include the title of the road show and the dates. The artefact may be functional or non-functional and consideration must be given to the choice of materials and production methods.

- 4 Design the front and back cover for a promotional CD to accompany the road show. The CD cover should include the title of the road show, the tour date and a creative image to represent **one** of the collections. The size is:

Front cover 12 cm × 12 cm; Back cover 11.75 cm × 15.1 cm

Standard CD jewel case cover

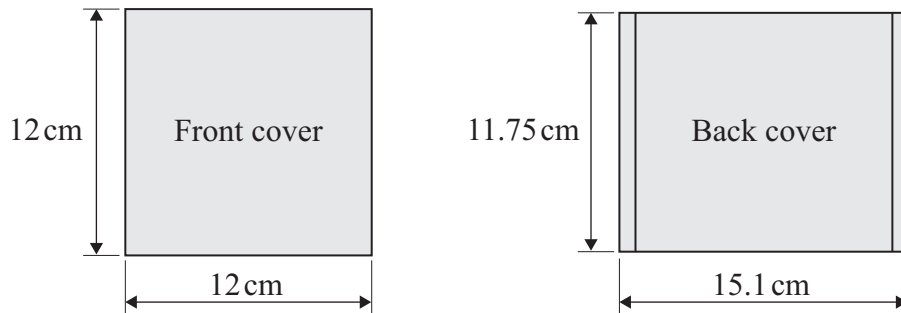

- 5 Design a single-sided textile fan bunting for the tour. The bunting should use motifs associated with any aspect of seafaring and text may be used. A range of textile techniques should be used and the fan bunting must be pleated. The size is:

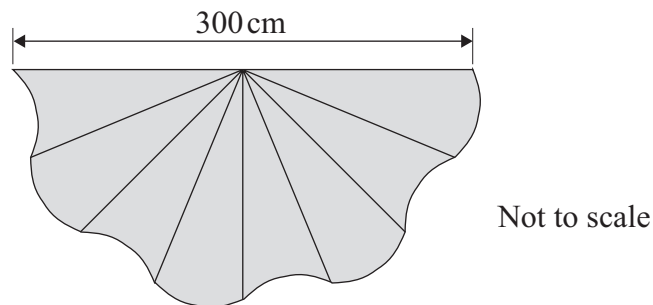

**Ensure that in your final submission you state clearly which brief you have chosen.**

**Turn over ►**

### Assessment requirements for GCSE in Applied Art and Design (Double Award) Unit 3: Working to project briefs

#### You should produce:

- research and developmental work to meet the brief
- a design proposal, suitably presented, that meets the requirements of the brief
- a short written evaluation of your design proposal.

#### Assessment marking criteria

Level 1:	Level 2:	Level 3:
<ul style="list-style-type: none"> <li>• work to the requirements of the brief, considering the topic or theme, constraints and deadline (0–3 marks)</li> <li>• collect relevant information to help you understand the requirements of the brief and develop more than one idea (0–3 marks)</li> <li>• use media, materials, techniques and technology with care (0–3 marks)</li> <li>• display your design proposal for the client (0–3 marks)</li> <li>• comment on your design proposal and explain how it might be improved (0–3 marks)</li> </ul>	<ul style="list-style-type: none"> <li>• create a range of possible ideas in response to the brief, showing potential alternatives that take account of constraints (4–6 marks)</li> <li>• collect and make effective use of primary and secondary source material to inform and develop different ideas, carry forward the most appropriate idea to produce a satisfactory design proposal (4–6 marks)</li> <li>• make effective use of materials, processes and techniques in developing ideas and the design proposal (4–6 marks)</li> <li>• display your design proposal effectively in a suitable way (4–6 marks)</li> <li>• use appropriate technical terms to annotate and comment on the strengths and weaknesses of both your ideas and design proposal (4–6 marks)</li> </ul>	<ul style="list-style-type: none"> <li>• offer a range of innovative responses to the brief that show an in-depth understanding of the requirements and constraints set by the brief (7–10 marks)</li> <li>• use a range of resources effectively, recording how you overcame unforeseen problems, to develop a design proposal that effectively meets the client's requirements (7–10 marks)</li> <li>• show confidence and fluency in your work through the use of media, materials and techniques (7–10 marks)</li> <li>• explain to the client how your design proposal meets the brief and how it has been influenced by similar work by others (7–10 marks)</li> <li>• evaluate your design proposal indicating changes of direction and how they affected the design proposal (7–10 marks)</li> </ul>

### END OF TEACHERS' NOTES

**There is no text printed on this page**

**There is no text printed on this page**