

Centre Number						Candidate Number				
Surname										
Other Names										
Candidate Signature										



General Certificate of Secondary Education
Foundation Tier

Applications of Mathematics (Linked Pair Pilot)

93702F

Unit 2 Foundation Tier

Specimen Paper

F

<p>For this paper you must have:</p> <ul style="list-style-type: none"> mathematical instruments. <p>You may use a calculator</p>	
---	--

Time allowed

- 1 hour 30 minutes

Instructions

- Use black ink or black ball-point pen. Draw diagrams in pencil.
- Fill in the boxes at the top of this page.
- Answer **all** questions.
- You must answer the questions in the space provided. Do not write outside the box around each page or on blank pages.
- Do all rough work in this book. Cross through any work that you do not want to be marked.
- If your calculator does not have a π button, take the value of π to be 3.14 unless another value is given in the question.

Information

- The marks for questions are shown in brackets.
- The maximum mark for this paper is 80.
- The quality of your written communication is specifically assessed in questions 6, 8, 11, 12, 15 and 16. These questions are indicated with an asterisk (*)
- You may ask for more answer paper, graph paper and tracing paper. These must be tagged securely to this answer booklet.
- You are expected to use a calculator where appropriate.

Advice

- In all calculations, show clearly how you work out your answer.

For Examiner's Use	
Examiner's Initials	
Pages	Mark
3	
4 - 5	
6 - 7	
8 - 9	
10 - 11	
12 - 13	
14 - 15	
16 - 17	
18 19	
20 -21	
22 - 23	
24	
TOTAL	

93702F

Formulae Sheet: Foundation Tier

Area of trapezium = $\frac{1}{2}(a + b)h$

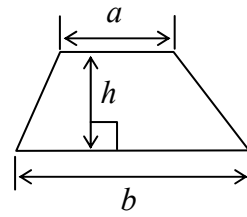

Volume of prism = area of cross-section \times length

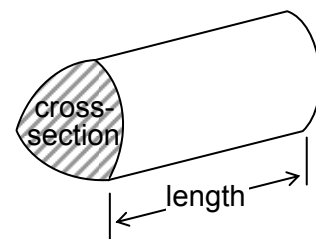

Answer **all** questions in the spaces provided.

- 1** Yuri is comparing some of his scores in his end of term examination results.

History $\frac{30}{50}$

ICT 72%

English 78 out of 100

In which subject did he get the highest score?

You **must** show your working.

.....

.....

.....

.....

Answer (2 marks)

- 2** Part of a map is shown.
A location can be given by a letter and a number.
For example, the school is in D2.

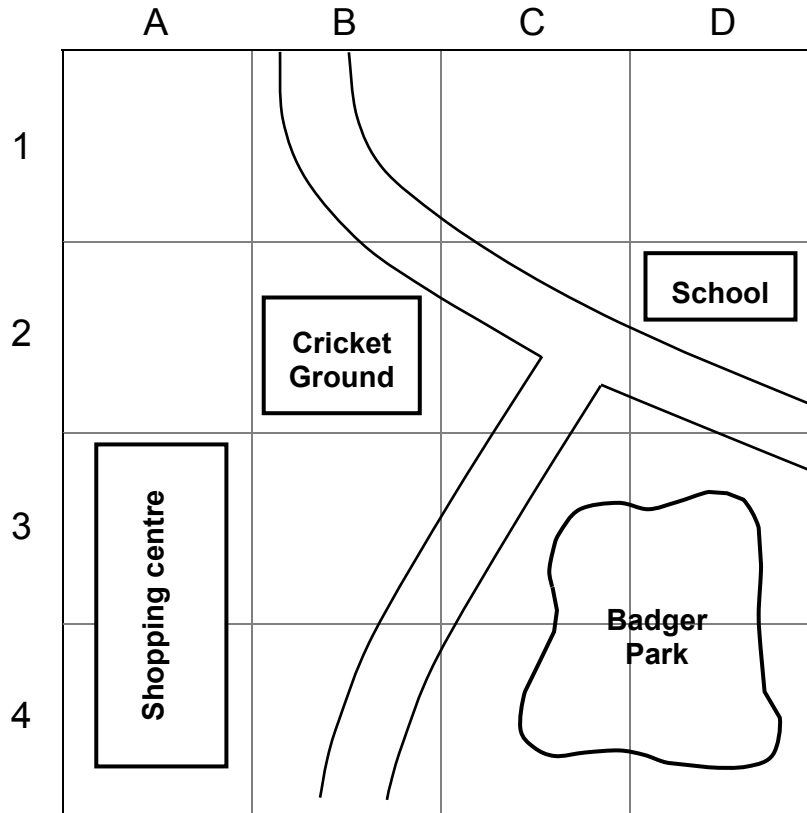

- 2 (a)** In which square is the cricket ground?

Answer (1 mark)

- 2 (b)** Badger Park occupies several squares.

List all the squares.

.....
.....

Answer (2 marks)

- 2 (c)** The school is due East of the cricket ground.

Complete this sentence.

The cricket ground is due of the school.

(1 mark)

3 Harry's garden is a rectangle measuring 9 metres by 6 metres.
He decides to make one-third of the area into a vegetable plot and the rest into a lawn.

3 (a) On the grid draw accurately a possible design for Harry's garden.

Use the scale 1 centimetre represents 1 metre.

Label your design.

1 cm represents 1 m



(4 marks)

3 (b) Lawn turf (grass) costs £2.50 per square metre.

How much will it cost Harry to turf his new lawn?

.....

.....

.....

.....

Answer £ (3 marks)

- 4 A rectangular picture frame is made using four pieces of wood.

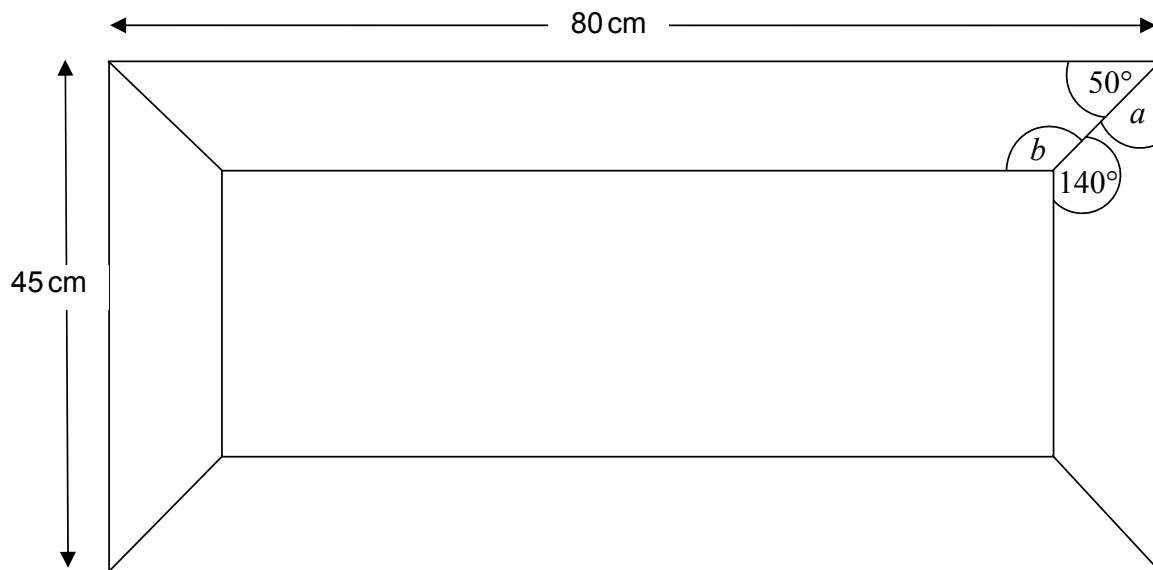

- 4 (a) (i) Work out angle a .

.....

Answer degrees (1 mark)

- 4 (a) (ii) Work out angle b .

.....

Answer degrees (2 marks)

- 4 (b) Work out the total length of the four pieces of wood needed to make the picture frame.
 Give your answer in metres.

.....

Answer metres (3 marks)

5 Femi drives from England to France.

5 (a) Before she goes she looks up how many euros she will get for the pound.

One website says	£ 1 = 1.815 euros
On a different website it says	£ 1 = 1.792467 euros

Femi rounds the number of euros and says they are the same.

How many decimal places has she rounded to?

.....

Answer (1 mark)

5 (b) In France road signs give the distances in kilometres.

Femi knows that 8 kilometres is about 5 miles.

She sees this sign.

Paris 120 km

How many miles is she from Paris?

.....

.....

Answer miles (2 marks)

- * 6 Motorists should drive with a safe gap between their vehicle and the vehicle in front. The graph shows the minimum safe gap between vehicles at different speeds. Different gaps are recommended for wet roads and dry roads.

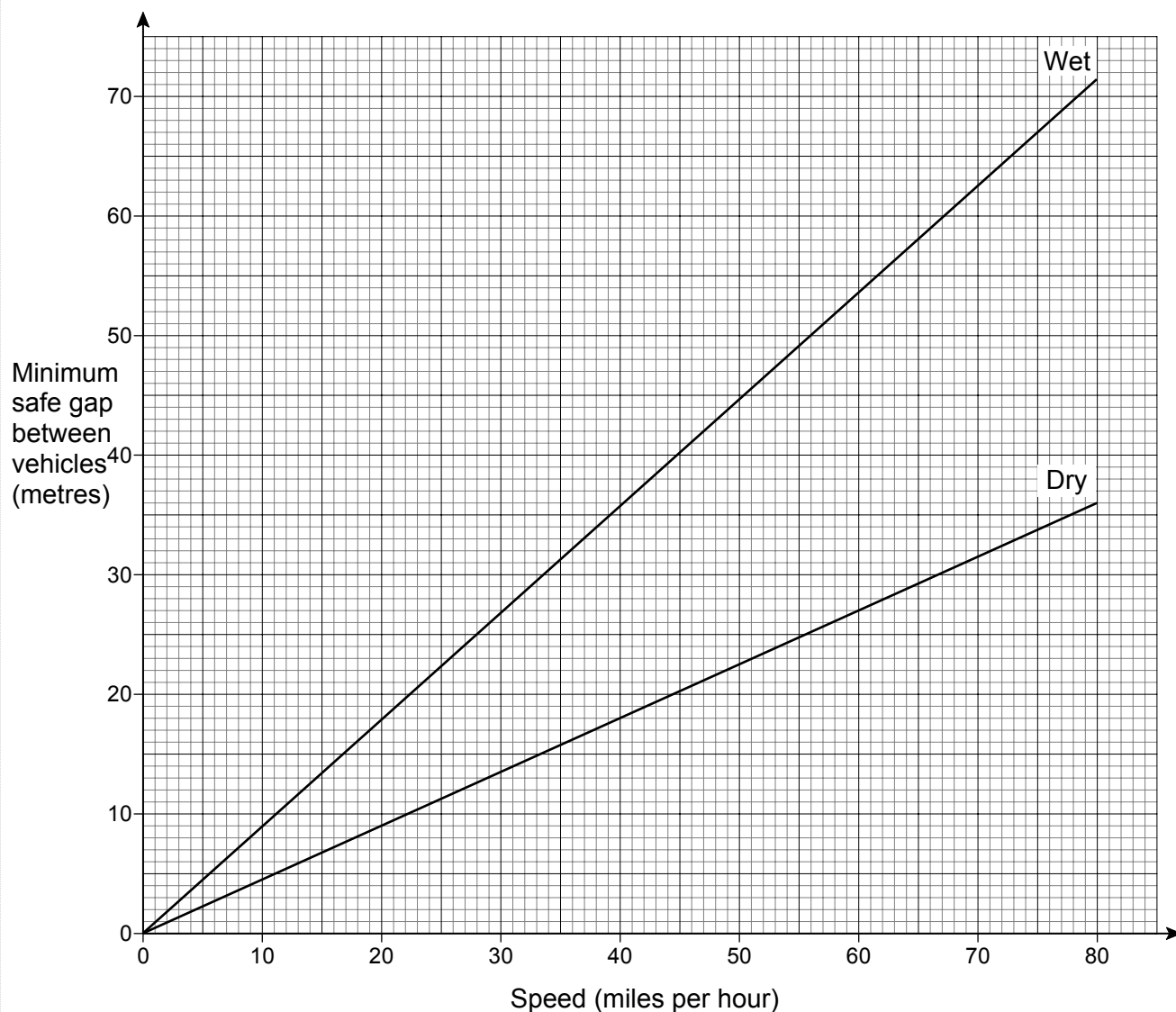

Tim is driving at 60 miles per hour on a dry road.

He is driving with the minimum safe gap between his car and the car in front.

It starts to rain heavily and both cars slow down to 40 miles per hour.

Should Tim increase the gap between his car and the car in front to continue driving with the minimum safe gap?

You **must** show clearly how you obtain your answer.

.....

.....

.....

.....

.....

(3 marks)

- 7 On a crossword grid some squares are shaded in.

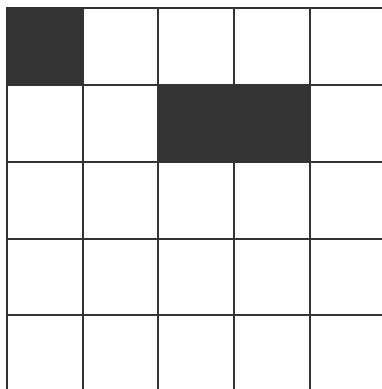

Shade in three more squares so that the grid has rotational symmetry of order 2

(2 marks)

- 8 (a) Tina invests £400 in a savings account.

She knows that the value of her investment after two years can be worked out using this calculation.

$$£400 \times 1.032^2$$

Work out the value of her investment after two years.

Give your answer to the nearest penny.

.....

.....

.....

Answer £ (2 marks)

- * 8 (b) Javed invests £400 in a savings bond.

After two years 5% interest is added to his investment.

Is the value of Javed's investment, after two years, higher or lower than Tina's?

You **must** show your working.

.....

.....

.....

(3 marks)

- 9 Here is part of the plan view of the second floor of two semi-detached houses. When semi-detached houses are built the layout of the rooms is symmetrical. The wall between the houses, AB, is a line of symmetry.

- 9 (a) Complete the plan view.

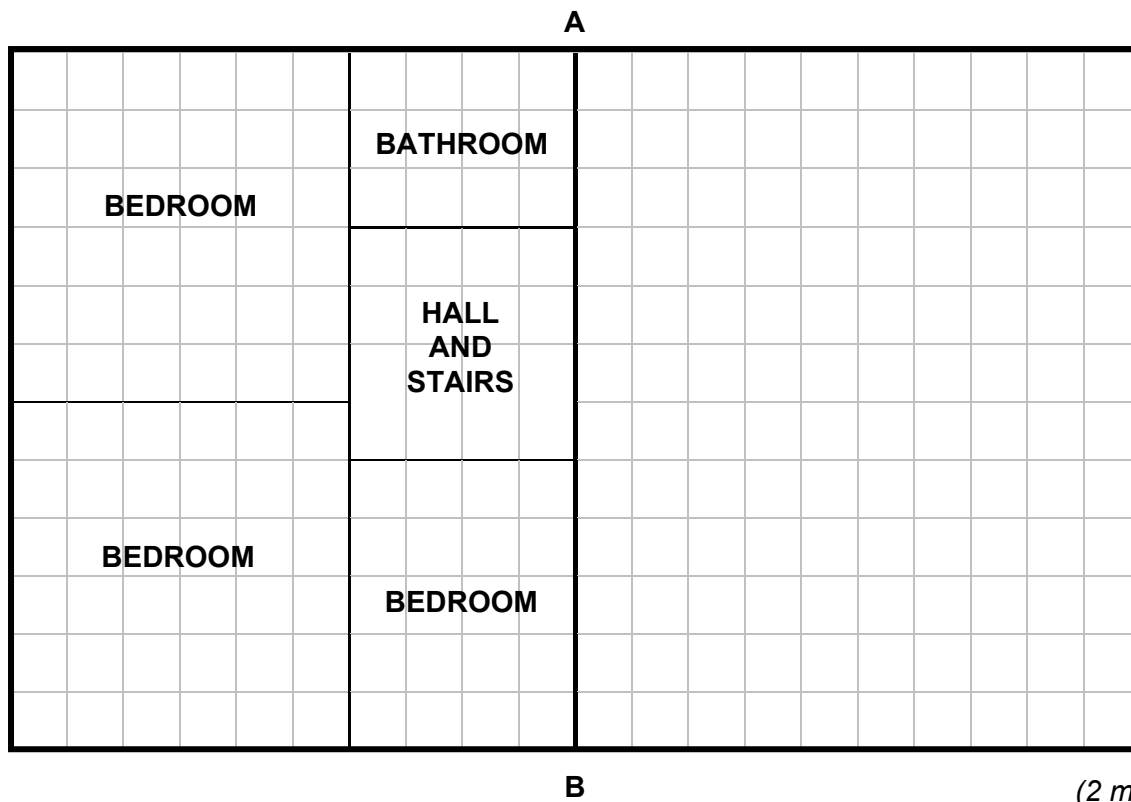

(2 marks)

9 (b) Here is a side elevation of the stairs in a house.

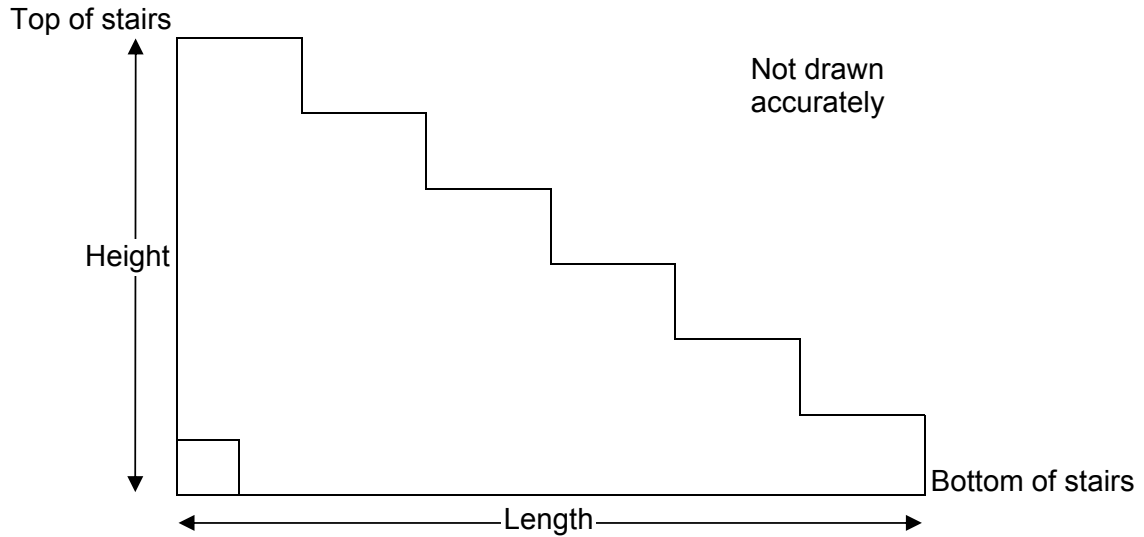

A safety rule is *length divided by height must be greater than 1.1*

Stairs are to be built with a height of 295 cm.

This diagram shows a design that does **not** fit the safety rule.

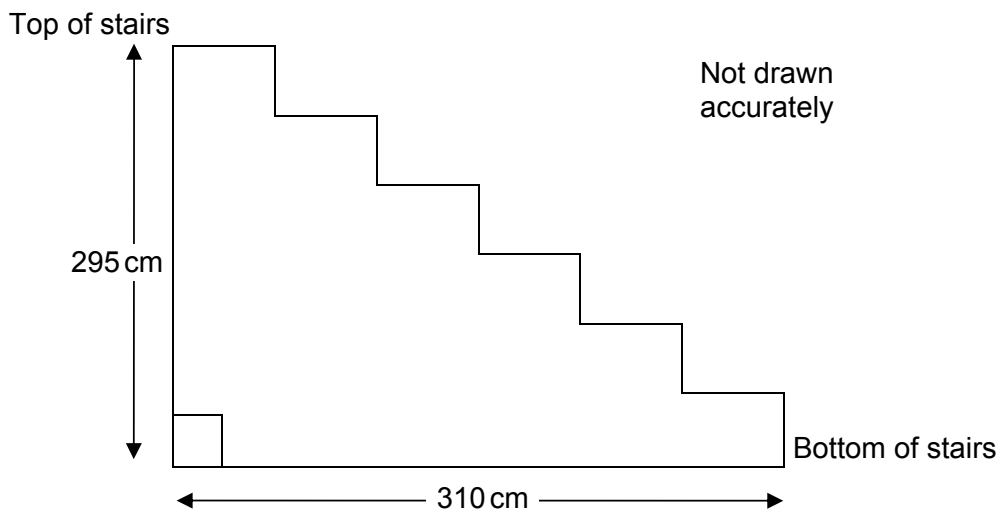

What is the least number of centimetres that the length must be increased by so that the design does fit the safety rule?

.....

.....

.....

.....

.....

Answer cm (3 marks)

5

- 10** In 2012 the Olympic Games are being held in London.
They were last held in London in 1948.
The Games are held every 4 years.

- 10 (a)** How many times have the Games been held between these years.

.....

Answer (2 marks)

- 10 (b)** The Olympic logo is drawn below:

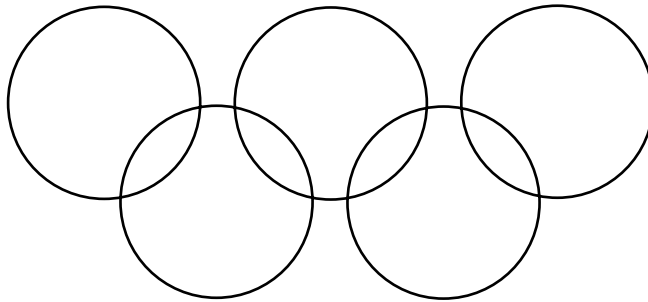

Draw any lines of symmetry on the diagram.

(1 mark)

- 10 (c)** Martin uses this system to give each country a points score.

A gold medal = 5 points
A silver medal = 3 points
A bronze medal = 1 point

At the last Games Great Britain won 19 gold, 13 silver and 15 bronze medals.

How many points did Great Britain score?

.....

.....

Answer (2 marks)

- 10 (d)** The podium that the medal winners stand on is made up of cuboids attached together to look like this.

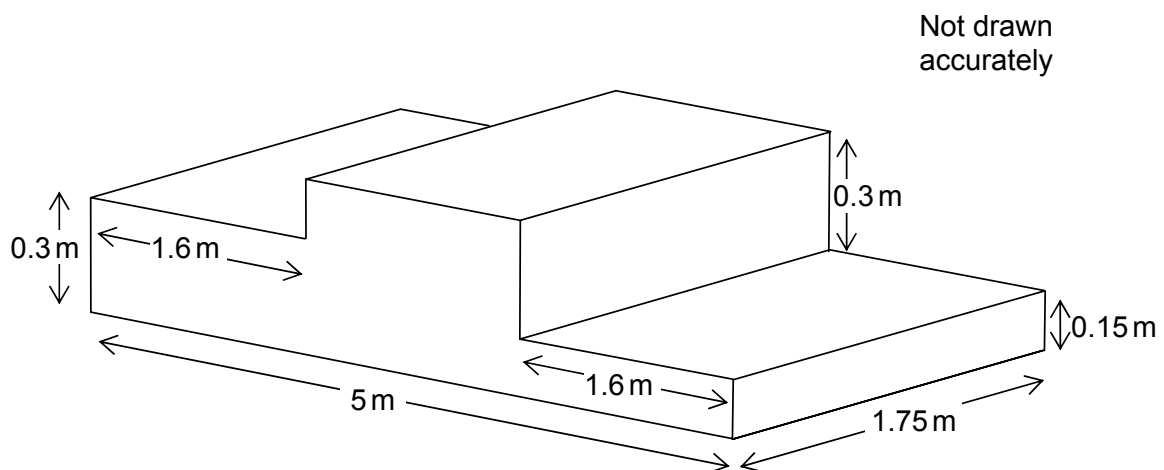

Work out the volume of the podium.

.....

.....

.....

Answer m^3 (4 marks)

*11(a) The basic monthly charge for a mobile phone contract is £35.

This includes:

Option 1 300 free minutes of calls and 100 free texts

or

Option 2 100 free minutes of calls and unlimited free texts.

All other calls are charged at 6 p per minute.

Extra texts are charged at 10 p each.

On average, each month, Matt makes 500 minutes of calls and sends 250 texts.

Which option should he choose?

You **must** show your working.

.....

.....

.....

.....

.....

.....

.....

.....

.....

.....

.....

.....

.....

.....

.....

.....

.....

.....

.....

.....

.....

.....

.....

Answer (5 marks)

- *12 Here is the net of a cereal box.
The cereal box is made of card.

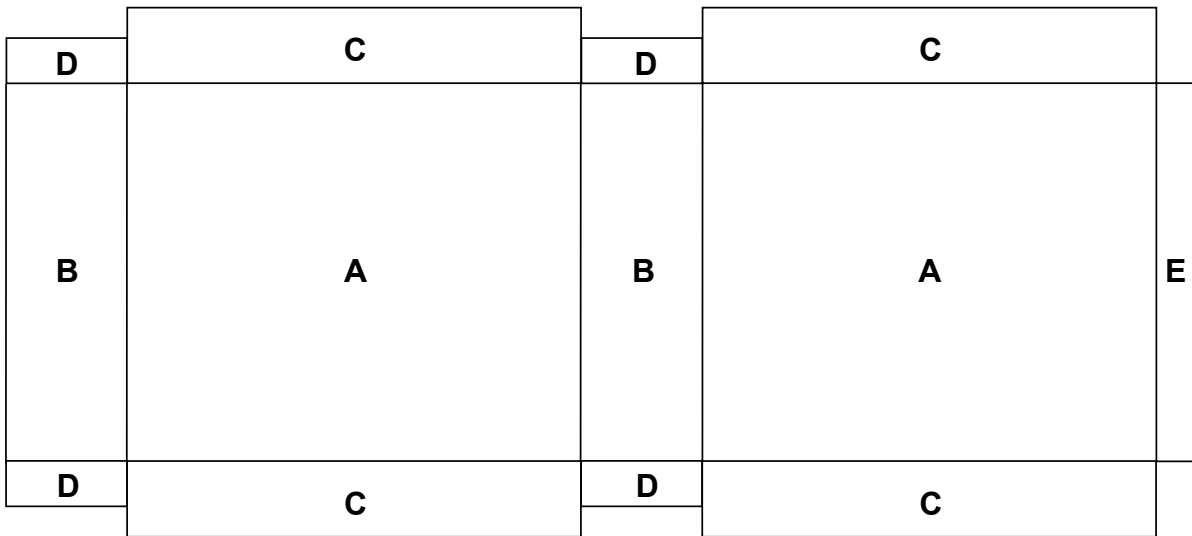

The same letter is used for rectangles that are the same size.
The table gives the lengths and widths of the rectangles.

Rectangle	Length in cm	Width in cm
A	25	18
B	25	5
C	18	3
D	5	2
E	25	1

- 12 (a) Show the area of card needed to make the box is 1431 cm^2 .

.....

.....

.....

.....

.....

.....

.....

(4 marks)

- 12 (b)** Joe has a square piece of card of edge 40 cm.
He says

My card has an area of 1600 cm^2 .
This is more than 1431 cm^2 .
I have enough card to make the net.



Is Joe correct?

Give a reason for your answer.

.....

.....

.....

.....

.....

.....

(2 marks)

Turn over for the next question

13 Ali uses this method to estimate the height of a flag pole.

- He stands, as shown, so that his angle of sight is 45° when he looks up to the top of the flag pole.
- He then measures his distance from the flagpole.
- Finally he measures the distance that his eyes are above the ground.

The sketch shows Ali's measurements.

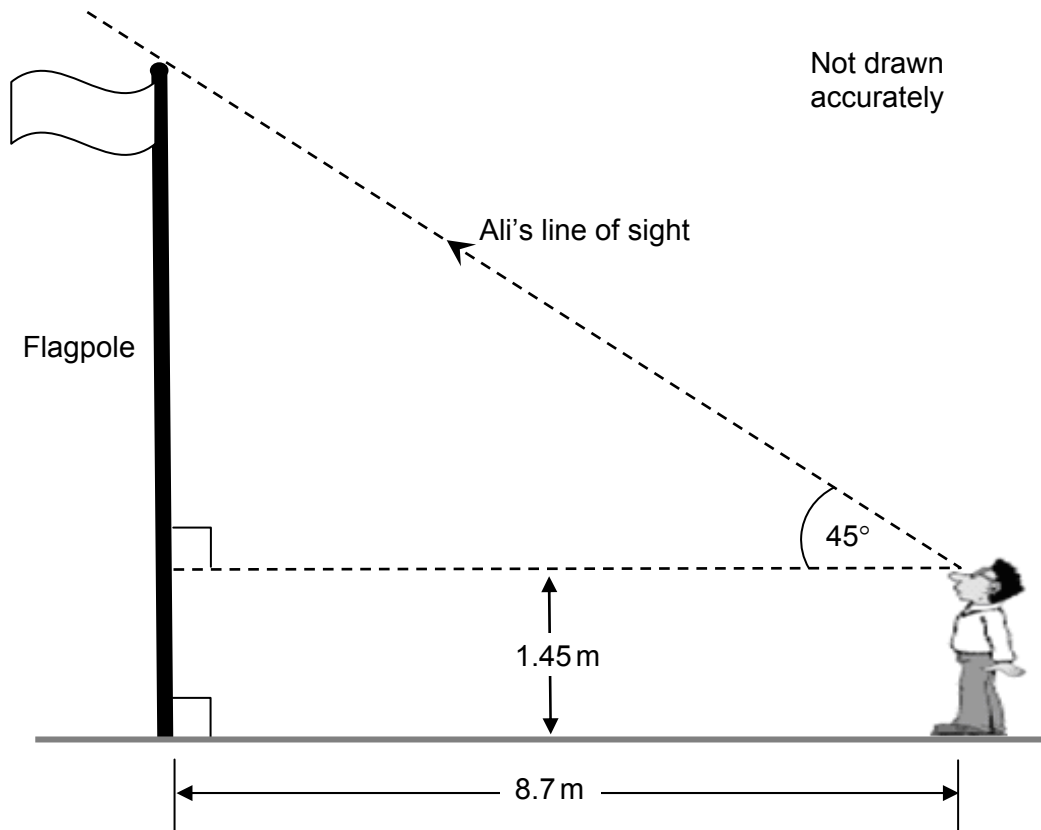

13 (a) Use Ali's measurements to calculate the height of the flag pole, explaining why he uses an angle of 45° .

.....

.....

.....

.....

Answer m (2 marks)

13 (b) Ben uses this method to estimate the height of a building.

- He tapes a 1 metre ruler to the building
- He takes a photograph of the building and the metre ruler.

On the photograph he measures the height of the building and the length of the ruler.

The measurements are shown in this sketch.

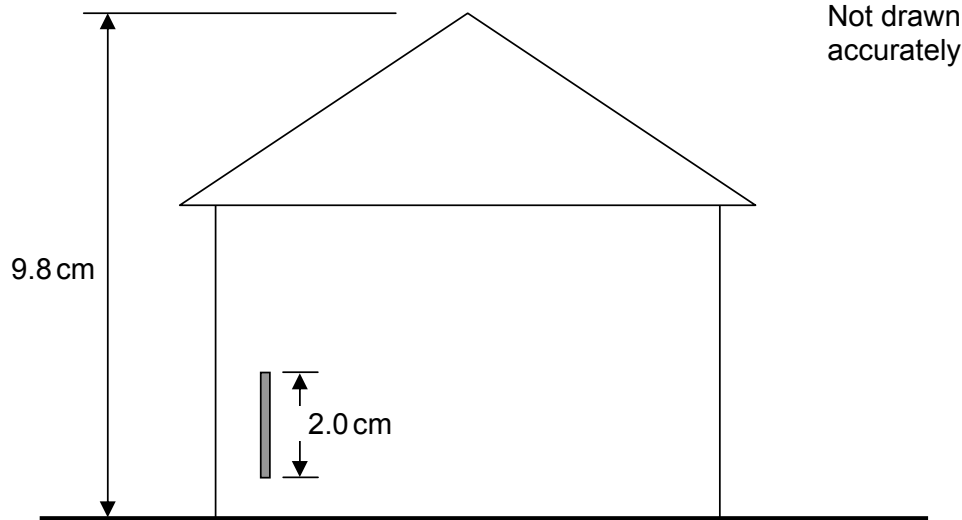

Use this information to estimate the height of the building.

Give your answer to the nearest metre.

.....

.....

.....

.....

Answer metres (3 marks)

- 14** The diagram shows the sketch of a lawn.
There is an electrical power point at C.
An electric lawnmower has a cable of length 15 metres.

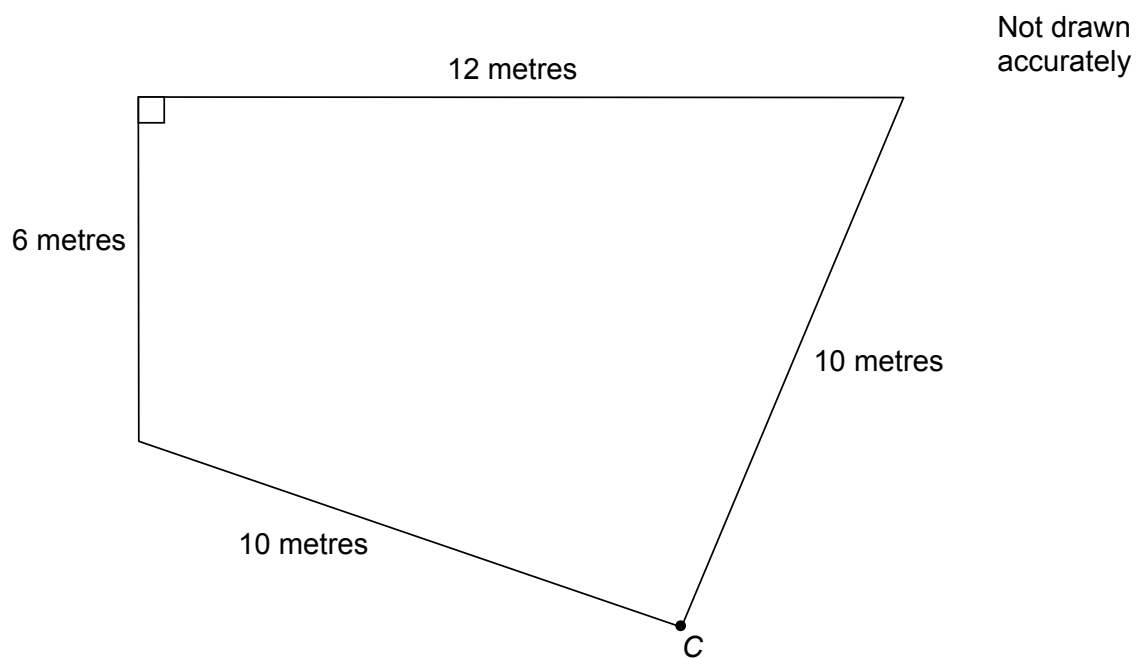

By making an accurate scale drawing of the lawn on the page opposite show that the cable is long enough for the whole lawn to be mowed.
Use a scale of 1 cm to represent 1 metre.
One side has been drawn for you.

1 cm represents 1 m

.....

.....

.....

.....

(4 marks)

4

Turn over ►

*15

A school canteen sells glasses of orange juice during the morning break.

The orange juice is bought in 2 litre cartons each costing £ 2.42.

1 litre = 1000 cm^3 .

Each glass is a cylinder with radius of 2.5 cm.

The orange juice is filled to a height of 9 cm.

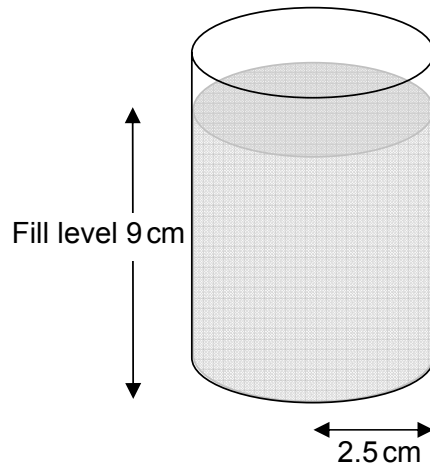

Not drawn
accurately

The canteen sells each glass of juice for 50 pence.

How much profit do they make on one 2 litre carton of juice?

You **must** show your working

.....

.....

.....

.....

.....

.....

.....

Answer (6 marks)

*16 The diagram shows a can of baked beans.

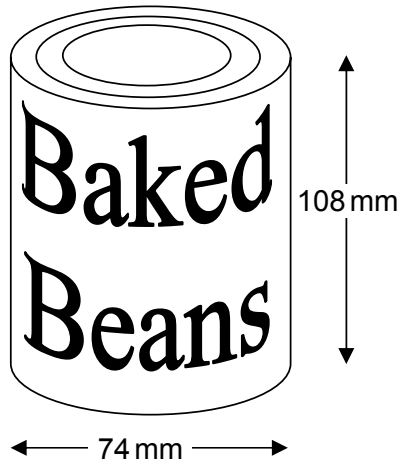

Not drawn
accurately

The cans are delivered to shops in cardboard boxes.
Each box contains 48 cans.

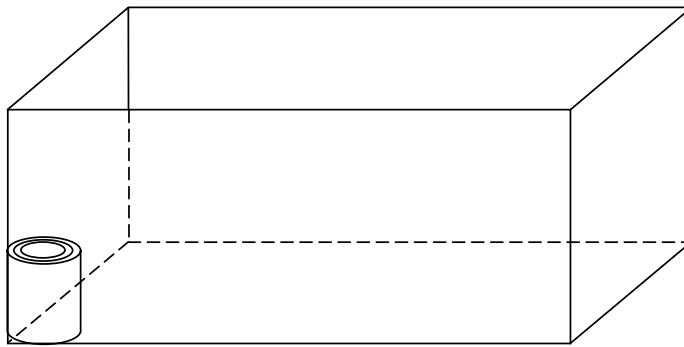

Not drawn
accurately

Work out suitable dimensions for one of these cardboard boxes

.....

.....

.....

.....

.....

.....

.....

.....

Answer mm by mm by mm (3 marks)

END OF QUESTIONS

There are no questions printed on this page

**DO NOT WRITE ON THIS PAGE
ANSWER IN THE SPACES PROVIDED**