

Candidate forename		Candidate surname	
-----------------------	--	----------------------	--

Centre number						Candidate number				
------------------	--	--	--	--	--	---------------------	--	--	--	--

**OXFORD CAMBRIDGE AND RSA EXAMINATIONS
GENERAL CERTIFICATE OF SECONDARY EDUCATION**

B624/02

**GATEWAY SCIENCE
ADDITIONAL SCIENCE B**

Unit 2 Modules B4 C4 P4 (Higher Tier)

TUESDAY 7 JUNE 2011: Afternoon

DURATION: 1 hour

SUITABLE FOR VISUALLY IMPAIRED CANDIDATES

**Candidates answer on the question paper.
A calculator may be used for this paper.**

OCR SUPPLIED MATERIALS:

None

OTHER MATERIALS REQUIRED:

Pencil

Ruler (cm/mm)

READ INSTRUCTIONS OVERLEAF

INSTRUCTIONS TO CANDIDATES

- **Write your name, centre number and candidate number in the boxes on the first page. Please write clearly and in capital letters.**
- **Use black ink. Pencil may be used for graphs and diagrams only.**
- **Read each question carefully. Make sure you know what you have to do before starting your answer.**
- **Write your answer to each question in the space provided. Additional paper may be used if necessary but you must clearly show your candidate number, centre number and question number(s).**
- **Answer ALL the questions.**

INFORMATION FOR CANDIDATES

- **The number of marks is given in brackets [] at the end of each question or part question.**
- **A list of physics equations is printed on page three.**
- **The Periodic Table is provided.**
- **The total number of marks for this paper is 60.**

EQUATIONS

$$\text{speed} = \frac{\text{distance}}{\text{time taken}}$$

$$\text{acceleration} = \frac{\text{change in speed}}{\text{time taken}}$$

$$\text{force} = \text{mass} \times \text{acceleration}$$

$$\text{work done} = \text{force} \times \text{distance}$$

$$\text{power} = \frac{\text{work done}}{\text{time}}$$

$$\text{kinetic energy} = \frac{1}{2} mv^2$$

$$\text{potential energy} = mgh$$

$$\text{weight} = \text{mass} \times \text{gravitational field strength}$$

$$\text{resistance} = \frac{\text{voltage}}{\text{current}}$$

Answer ALL the questions.

SECTION A – MODULE B4

- 1 Read the article about the possibility of people living on the moon.**

CAN WE LIVE ON THE MOON?

One of the main problems with living on the moon is growing food.

There is no soil on the moon but plants could be grown with their roots in water that contains minerals. The water to grow the plants would have to come from Earth.

There is also very little carbon dioxide, a gas needed for photosynthesis.

There are other worries.

Due to the lower gravity the plants may not make strong enough xylem vessels.

Waste plant material will not rot as there are no microorganisms on the moon.

- (a) One problem with growing plants on the moon is the lack of carbon dioxide.**

Animals living in a moon station could provide the carbon dioxide.

Which chemical process in animals produces carbon dioxide?

[1]

- (b) (i) Scientists plan to grow the plants in water rather than soil.**

What is the name of this type of growing method?

_____ [1]

- (ii) Farmers can grow plants in water on Earth.**

Write down ONE advantage of growing plants in water rather than soil.

_____ [1]

- (c) Scientists are worried that the xylem vessels may not be able to support the plants.**

Which part of a xylem vessel provides the strength to support a plant?

_____ [1]

(d) The scientists investigate a number of different food plants that they might grow.

They use a computer to predict the yield of food plants when grown in water.

The table shows how this yield compares with the yield when grown in soil.

FOOD PLANT	YIELD WHEN GROWN IN SOIL IN ARBITRARY UNITS	YIELD WHEN GROWN IN WATER IN ARBITRARY UNITS	PERCENTAGE OF PLANT THAT CAN BE EATEN
beans	2.4	20.0	22
broccoli	3.8	13.0	33
cabbage	10.8	41.4	67
cucumbers	5.4	65.7	20

Suggest the advantages and disadvantages of choosing cucumbers to grow in water on the moon.

Use data from the table to support your answer.

[3]

[Total: 7]

2 Scientists are developing power stations that do not use fossil fuels.

(a) (i) One possibility is to use biomass as a fuel.

Alcohol can be used as a fuel and is made from biomass.

How can alcohol be made from biomass?

_____ [1]

(ii) One reason for using biomass as a fuel is that it produces less pollution than fossil fuels.

Explain why.

_____ [1]

(b) Another alternative to using fossil fuels is using osmosis.

The world's first power station that uses osmosis has opened in Norway.

The station has two large tanks of liquid separated by a partially-permeable membrane.

One tank contains fresh water, the other contains sea water.

Sea water contains a higher concentration of salt than fresh water.

The level in the sea water tank rises and this can be used to generate electricity.

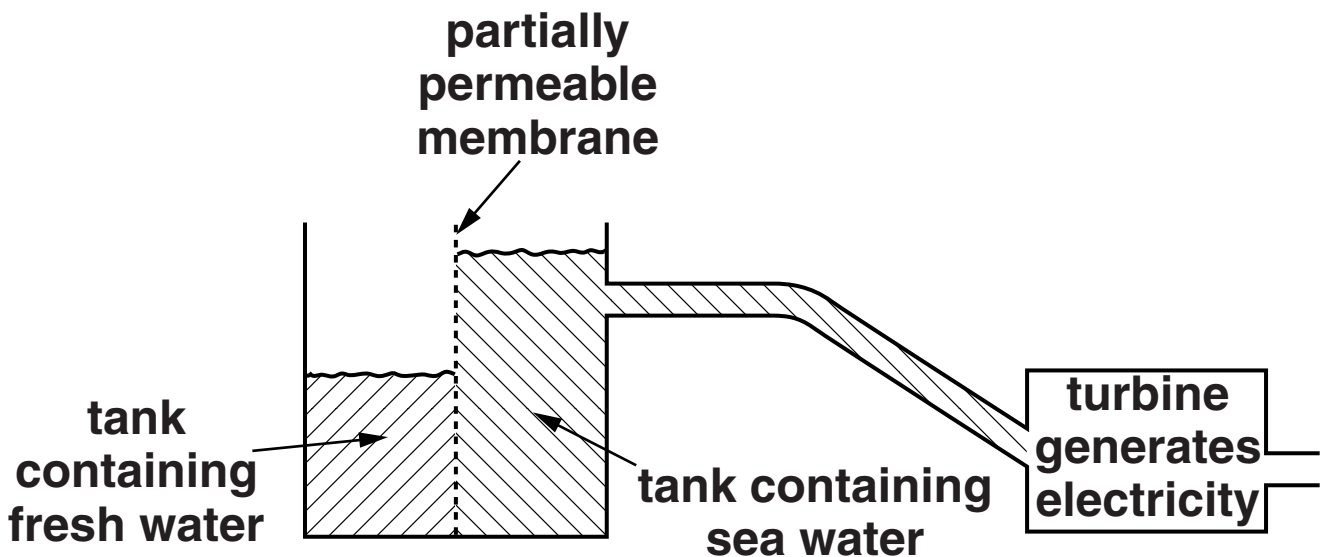

(i) The power station uses a PARTIALLY-PERMEABLE membrane.

What is meant by partially-permeable?

[1]

(ii) Which statement best describes why the level rises in the sea water tank?

Put a tick (✓) in the box next to the best reason.

Osmosis causes water to move from a dilute salt solution to a concentrated salt solution.

Osmosis causes salt to move from a dilute salt solution to a concentrated salt solution.

Osmosis causes water to move from a concentrated salt solution to a dilute salt solution.

Osmosis causes salt to move from a concentrated salt solution to a dilute salt solution.

[1]

[Total: 4]

3 Giles is a farmer.

He grows celery.

(a) The celery plants need sunlight to grow.

A green chemical in the celery leaves absorbs sunlight.

Write down the name of this green chemical.

[1]

(b) Giles finds that his celery plants have been attacked by a pest.

This pest is called the celery leaf miner.

It enters the leaf and eats some of the cells inside.

This is shown in the diagram.

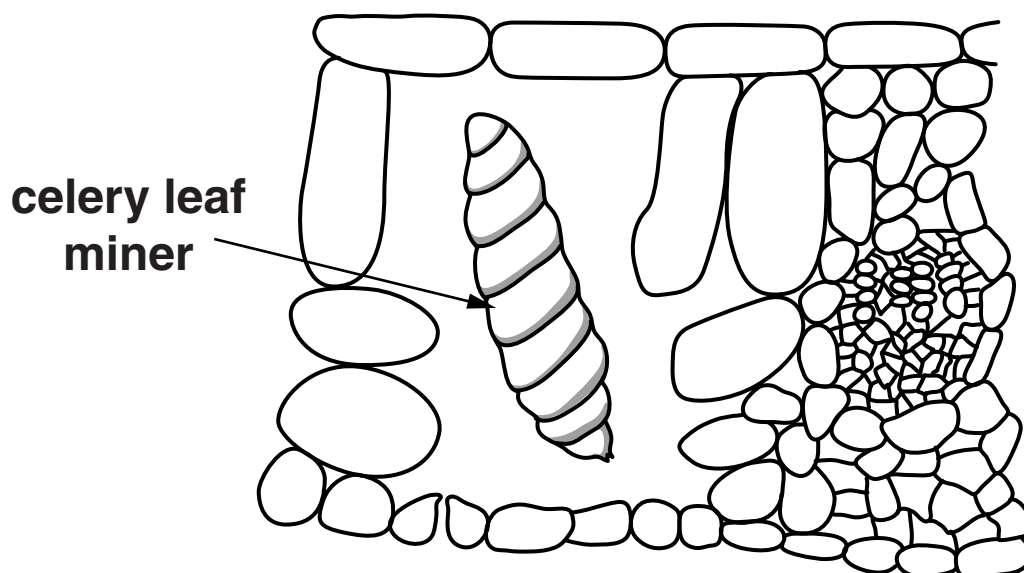

- (i) The celery leaf miner has eaten cells from TWO layers in the leaf.**

Write down the names of these two layers of cells.

_____ and

_____ [2]

- (ii) When these particular cells are eaten, the rest of the celery plant does not grow as well.**

Explain why.

_____ [1]

(c) Giles wants his celery plants to grow bigger.

He reads that plants need plenty of nitrates to grow well.

He decides to add compost to his soil to help the celery grow.

The diagram shows how compost is converted into nitrates.

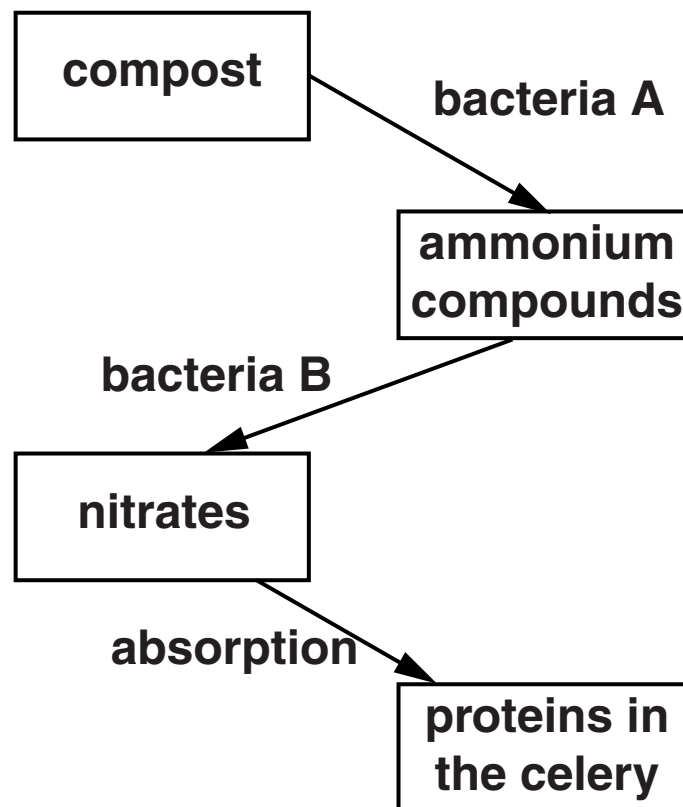

(i) Write down the names of the two types of bacteria shown as A and B.

bacteria A _____

bacteria B _____

[2]

- (ii) The nitrates will be produced more slowly in cold weather.**

Explain why.

_____ [1]

- (iii) The nitrates are absorbed from the soil by the roots of the celery plants.**

This can only happen if there is enough oxygen in the soil.

Put ticks (✓) next to the TWO statements that BEST explain why.

Minerals are absorbed from the soil dissolved in oxygen.

Minerals are absorbed by active transport.

If respiration stops then osmosis stops.

Diffusion of minerals occurs faster in high oxygen levels.

Plants take up minerals from a high concentration in the soil.

Oxygen is needed for respiration.

Osmosis occurs in plant root hair cells.

[2]

[Total: 9]

SECTION B – MODULE C4

4 Mary is making a fertiliser by neutralisation.

Look at the diagram. It shows the apparatus she uses.

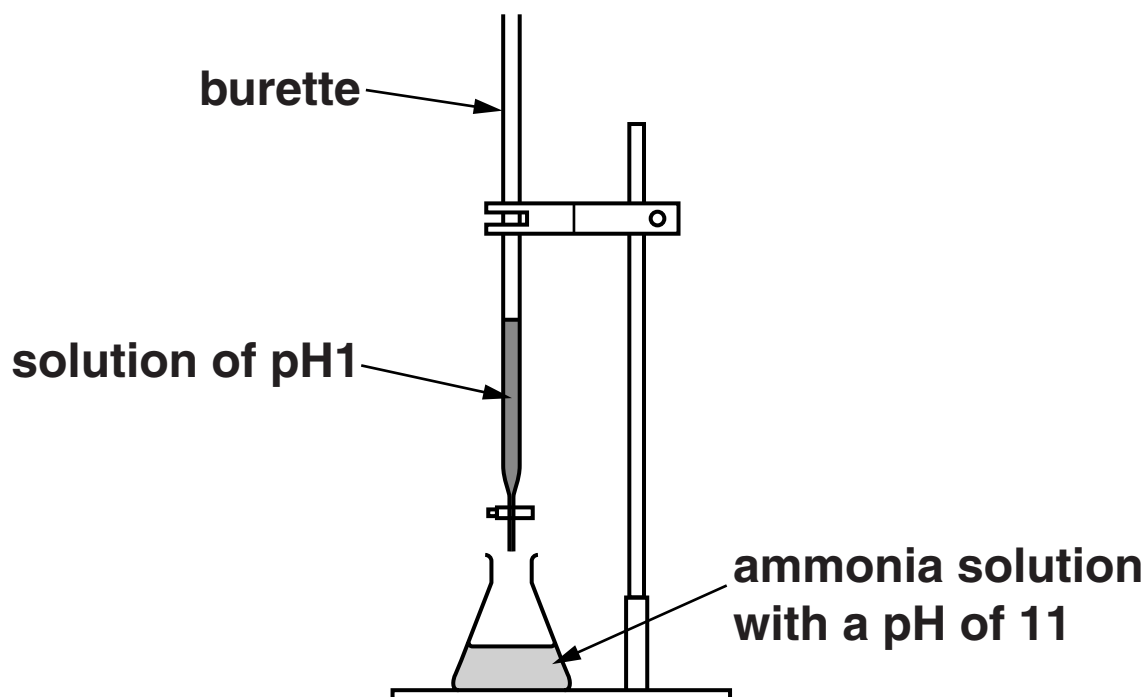

Mary adds the liquid in the burette to the ammonia solution in the flask.

She stops adding the liquid when the solution in the flask has a pH of 7.

Mary evaporates the solution in the flask to make the solid fertiliser.

(a) The reaction in the flask is a **NEUTRALISATION** reaction.

Complete the word equation for neutralisation.

acid + base \rightarrow _____ + water [1]

(b) All acids, in solution, contain hydrogen ions, H⁺.

All alkalis, in solution, contain hydroxide ions, OH⁻.

Write an IONIC equation for neutralisation.

_____ [1]

(c) Mary predicts she will make 4.8 g of fertiliser.

She actually makes 4.2 g.

Calculate her percentage yield.

answer _____ % [2]

(d) Mary reacts copper oxide with sulfuric acid.

Write a WORD equation for this reaction.

_____ [1]

(e) Sulfuric acid also reacts with magnesium carbonate.

Complete the WORD equation for the reaction.

magnesium + sulfuric → magnesium + water +
carbonate acid sulfate

[1]

(f) Urea, $\text{CO}(\text{NH}_2)_2$, is another fertiliser.

It is made by heating carbon dioxide with ammonia, NH_3 .

Look at the equation.



Calculate the mass of urea, $\text{CO}(\text{NH}_2)_2$, that can be made from 17 tonnes of ammonia, NH_3 .

The relative atomic mass, A_r , of C is 12, of O is 16, of N is 14 and of H is 1.

answer _____ tonnes [3]

[Total: 9]

BLANK PAGE

QUESTION 5 BEGINS ON PAGE 18

5 This question is about making medicines.

(a) Some of the chemicals needed to make medicines are extracted from plants.

Write about ONE way chemicals can be extracted from plants.

Your answer should include

- **what is done to the plant**
- **how the chemical is removed**
- **how the chemical is purified.**

You may wish to draw diagrams.

6 This question is about drinking water.

(a) Washing-up liquid can pollute drinking water.

Another pollutant is nitrates.

Suggest how nitrates could get into drinking water.

_____ [1]

(b) Joe is testing some water samples.

He adds silver nitrate solution and barium chloride solution to different water samples.

Look at the table. It shows his results.

WATER SAMPLE	RESULT WITH SILVER NITRATE SOLUTION	RESULT WITH BARIUM CHLORIDE SOLUTION
A	white precipitate	colourless solution
B	cream precipitate	colourless solution
C	colourless solution	white precipitate
D	_____	_____

(i) Which water sample contains bromide ions?

_____ [1]

(ii) Which water sample contains chloride ions?

_____ [1]

(iii) Sample D contains IODIDE ions and SULFATE ions.

Complete the table to show Joe's results. [1]

(iv) Water containing sodium sulfate, Na_2SO_4 , reacts with barium chloride solution, BaCl_2 .

Barium sulfate, BaSO_4 , and sodium chloride, NaCl , are made.

Write a BALANCED SYMBOL equation for this reaction.

_____ [2]

[Total: 6]

SECTION C – MODULE P4

7 This question is about electrostatics.

(a) Lorna wears a nylon coat. The coat becomes charged.

This is because charged particles move between the coat and Lorna.

Write down the NAME of the charged particles involved.

_____ [1]

(b) Static electricity can be useful.

It is used to restart the heart when it has stopped.

Write about how static electricity is used to restart a heart when it has stopped.

Your answer should include

- the method used**
- the safety precautions.**

_____ [3]

[Total: 4]

8 Marc builds the following circuit.

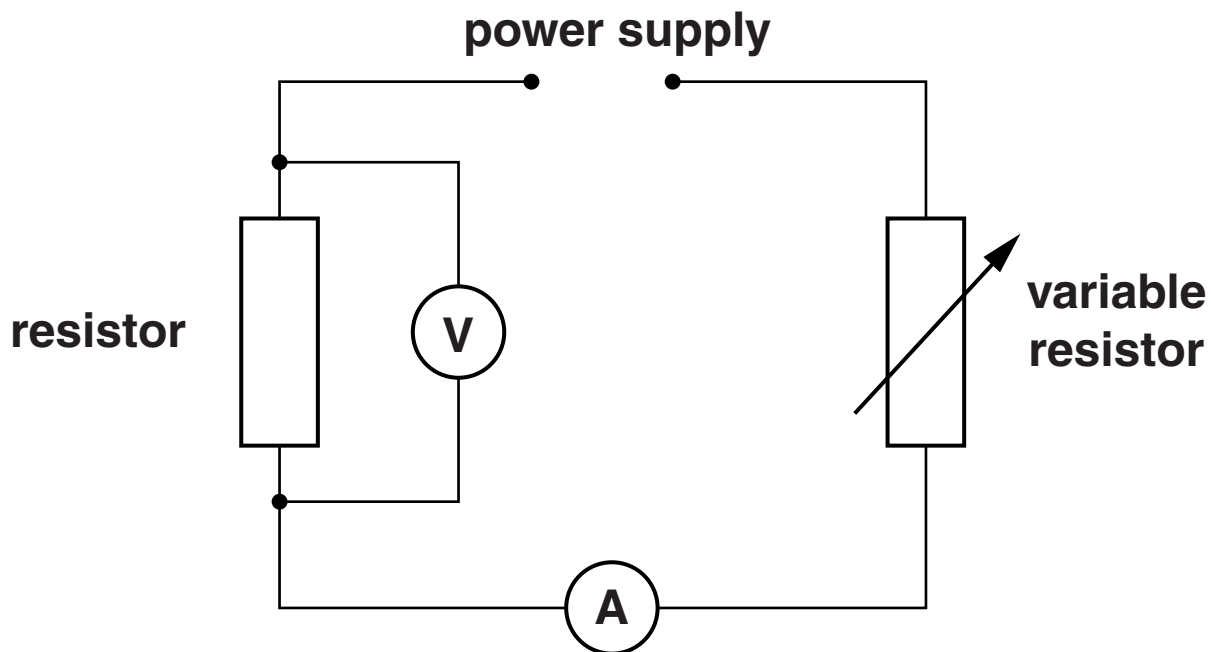

The reading on the voltmeter is 15V and the reading on the ammeter is 4 A.

Calculate the resistance of the resistor.

The equations on page 3 may help you.

answer _____ ohms [2]

[Total: 2]

9 Ultrasound can be used for body scans.

Look at the picture of a patient having a chest scan.

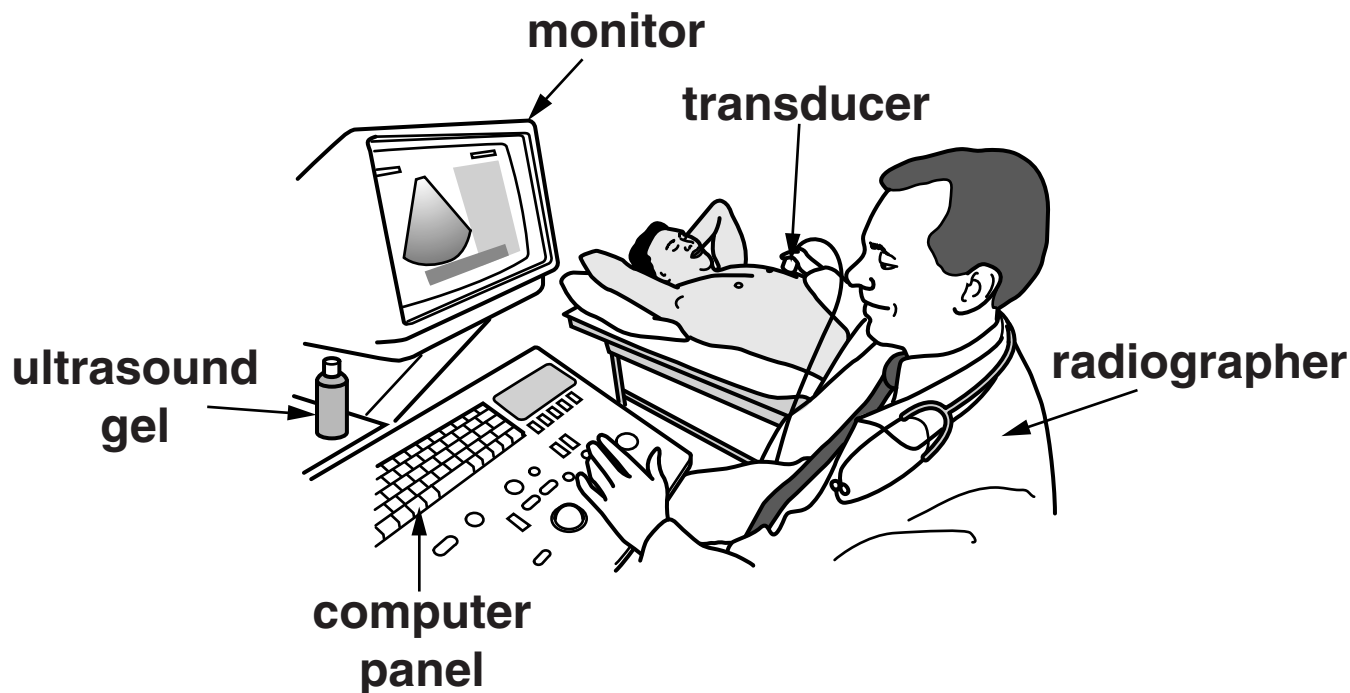

(a) How does ultrasound produce images of the body's internal organs?

In your answer write about

- **the properties of ultrasound that make it suitable to use**
- **how the image is built up.**

[2]

(b) Why do doctors prefer to use ultrasound rather than X-rays for many diagnoses?

[1]

[Total: 3]

10 This question is about radioactivity.

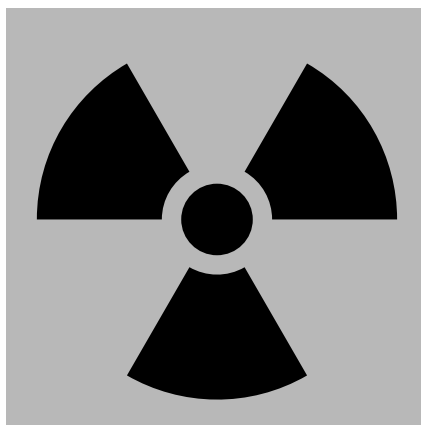

${}_{11}^{24}\text{Na}$ (sodium-24) is a radioactive isotope.

(a) A manufacturer produces some sodium-24.

It has a half-life of 15 hours.

(i) What is meant by half-life?

[1]

(ii) The radioactive sodium-24 (half-life 15 hours) leaves the manufacturer.

It is used in a hospital 30 hours later.

The count rate at the hospital is now 160 counts per minute (cpm).

Calculate the count rate when the sodium-24 left the manufacturer.

[2]

(b) Radioactive dating can be used to find the age of rocks.

(i) Complete the following sentence.

Choose words from this list.

CARBON

IRON

LEAD

PLUTONIUM

RADON

URANIUM

Scientists measure the amounts of two elements in a sample of rock.

The radioactive element

slowly changes into

_____ . [2]

(ii) Finish the sentence.

The age of the rock can be calculated by

_____ . [1]

[Total: 6]

11 (a) Look at the flow diagram of a nuclear power station. Two of the boxes have been left blank.



Complete the following sentences.

In the reactor, uranium undergoes a nuclear
_____ reaction, releasing energy.

This _____

the water and produces _____

which drives the _____ .

This turns the _____

producing electricity.

[3]

(b) Metals can be placed in a nuclear reactor.
They become radioactive.

Describe how this happens.

_____ [2]

[Total: 5]

END OF QUESTION PAPER

BLANK PAGE



Copyright Information

OCR is committed to seeking permission to reproduce all third-party content that it uses in its assessment materials. OCR has attempted to identify and contact all copyright holders whose work is used in this paper. To avoid the issue of disclosure of answer-related information to candidates, all copyright acknowledgements are reproduced in the OCR Copyright Acknowledgements Booklet. This is produced for each series of examinations and is freely available to download from our public website (www.ocr.org.uk) after the live examination series.

If OCR has unwittingly failed to correctly acknowledge or clear any third-party content in this assessment material, OCR will be happy to correct its mistake at the earliest possible opportunity.

For queries or further information please contact the Copyright Team, First Floor, 9 Hills Road, Cambridge CB2 1GE.

OCR is part of the Cambridge Assessment Group; Cambridge Assessment is the brand name of University of Cambridge Local Examinations Syndicate (UCLES), which is itself a department of the University of Cambridge.

