

Candidate Forename		Candidate Surname	
---------------------------	--	--------------------------	--

Centre Number						Candidate Number				
----------------------	--	--	--	--	--	-------------------------	--	--	--	--

**OXFORD CAMBRIDGE AND RSA EXAMINATIONS
GENERAL CERTIFICATE OF SECONDARY EDUCATION**

B623/02

**GATEWAY SCIENCE
ADDITIONAL SCIENCE B**

**UNIT 1 Modules B3 C3 P3
(Higher Tier)**

WEDNESDAY 20 MAY 2009: Afternoon

DURATION: 1 hour

SUITABLE FOR VISUALLY IMPAIRED CANDIDATES

**Candidates answer on the question paper
A calculator may be used for this paper**

OCR SUPPLIED MATERIALS:

None

OTHER MATERIALS REQUIRED:

Pencil

Ruler (cm/mm)

READ INSTRUCTIONS OVERLEAF

INSTRUCTIONS TO CANDIDATES

- Write your name clearly in capital letters, your Centre Number and Candidate Number in the boxes on the first page.
- Use black ink. Pencil may be used for graphs and diagrams only.
- Read each question carefully and make sure that you know what you have to do before starting your answer.
- Answer ALL the questions.
- Write your answer to each question in the space provided, however additional paper may be used if necessary.

INFORMATION FOR CANDIDATES

- The number of marks is given in brackets [] at the end of each question or part question.
- A list of physics equations is printed on page three.
- The Periodic Table is printed on the back page.
- The total number of marks for this paper is 60.

EQUATIONS

$$\text{speed} = \frac{\text{distance}}{\text{time taken}}$$

$$\text{acceleration} = \frac{\text{change in speed}}{\text{time taken}}$$

$$\text{force} = \text{mass} \times \text{acceleration}$$

$$\text{work done} = \text{force} \times \text{distance}$$

$$\text{power} = \frac{\text{work done}}{\text{time}}$$

$$\text{kinetic energy} = \frac{1}{2} mv^2$$

$$\text{potential energy} = mgh$$

$$\text{weight} = \text{mass} \times \text{gravitational field strength}$$

$$\text{resistance} = \frac{\text{voltage}}{\text{current}}$$

Answer ALL the questions.

SECTION A – MODULE B3

1 Sam is investigating roots.

She uses a microscope to look at a root hair cell.

The diagram shows one of the cells Sam sees.

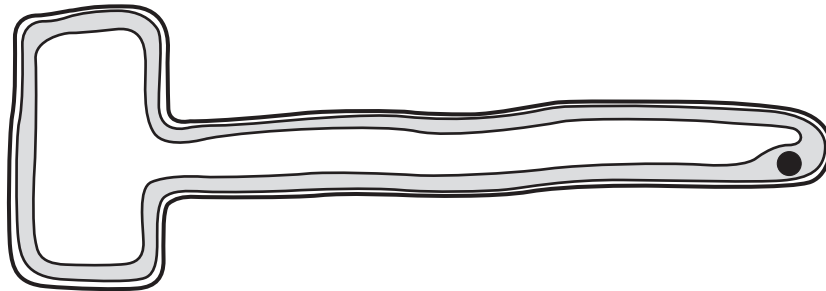

(a) Write down the name of ONE part of this cell NOT found in animal cells.

_____ [1]

(b) Oxygen moves into the root hair cell by diffusion.

What is meant by the term DIFFUSION?

_____ [1]

(c) Sam places a growing bean seed on a rotating disc.

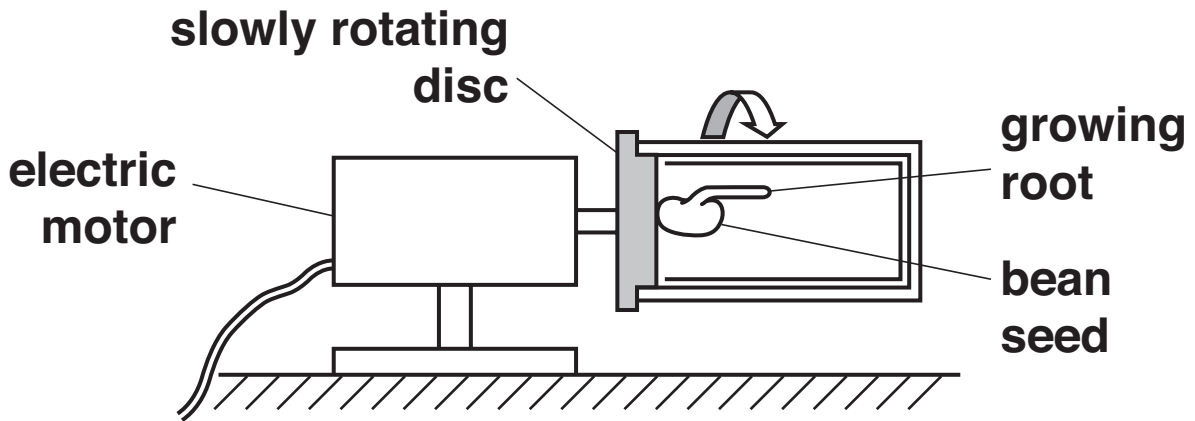

Finish the sentences about the growing root.

Roots normally grow downwards because they are positively _____ .

The root on this bean is growing outwards because Sam has removed the effect of _____ .

Root growth is controlled by a hormone called _____ .

[3]

[Total: 5]

2 This question is about fertilisation.

Sperm and egg cells carry out fertilisation.

They both have a nucleus to carry genes.

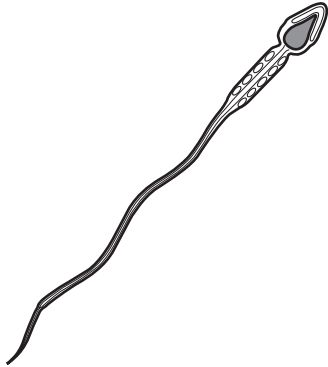

SPERM CELL
(not to scale)

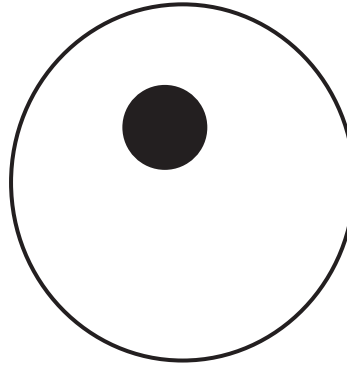

sperm cells
(drawn to
scale)

EGG CELL

(a) (i) Write down the name of the type of cell division that MAKES egg and sperm cells.

_____ [1]

(ii) This type of cell division is different to the cell division that makes body cells.

Describe ONE difference.

_____ [1]

(b) The nucleus of the egg and sperm both contain DNA.

After fertilisation the DNA replicates.

Describe the TWO stages involved in DNA replication.

You may draw a labelled diagram to help you.

1 _____

2 _____

_____ [2]

[Total: 4]

3 Carol grows carrots to enter in the biggest carrot competition.

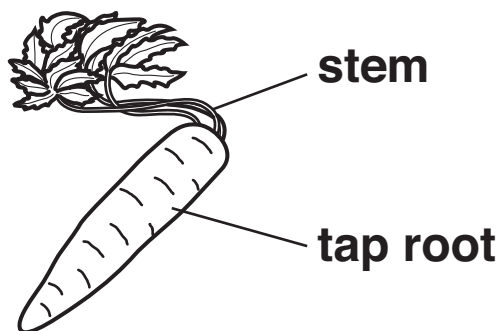

(a) She uses selective breeding to help her to produce large carrots.

(i) Describe how Carol would carry out the selective breeding process.

[2]

(ii) Describe ONE reason why selective breeding may cause problems to a species.

[1]

(b) Carrots contain a gene that controls beta-carotene production.

The beta-carotene gene can be removed from carrots and placed in rice plants.

This process can be used to help people who eat a lot of rice and have a vitamin A deficiency.

Explain why.

_____ [1]

[Total: 4]

4 Look at the diagram of an artery and vein.

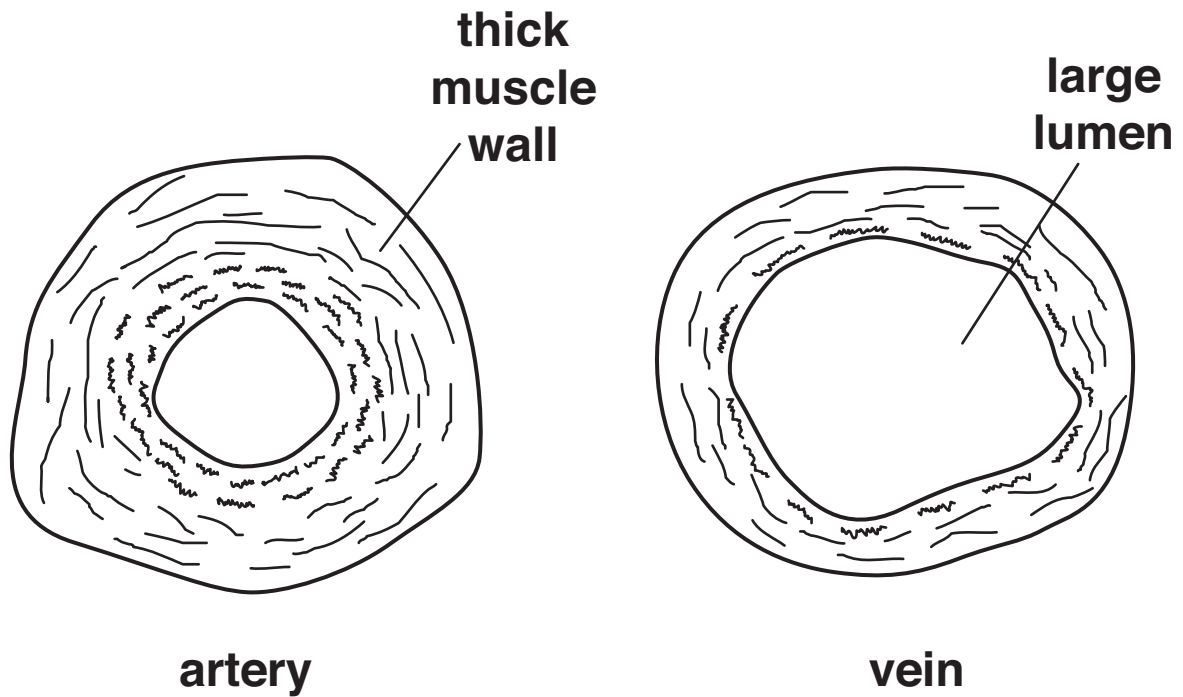

(a) Explain why the artery has a thick muscle wall.

[1]

(b) Explain why the vein has a large lumen.

[1]

[Total: 2]

5 Bill investigates the effect of the enzyme catalase.

He uses the enzyme to break down hydrogen peroxide into oxygen and water.

He measures the rate of the reaction by timing how long it takes to collect 10 cm³ of oxygen.

He repeats the reaction at different pH values.

The table shows his results.

pH	<u>TIME IN MINUTES</u>
2	no reaction
4	20
5	12
6	9
7	13
8	17

(a) Describe the pattern in the results between pH 4 and pH 8.

_____ [1]

(b) What is the optimum pH for catalase?

pH _____ [1]

(c) Explain the result for pH 2.

Use ideas about the lock and key theory in your answer.

[3]

[Total: 5]

SECTION B – MODULE C3

6 This question is about the elements in the Periodic Table.

Look at the list of elements.

ARGON

CHROMIUM

HYDROGEN

IODINE

MAGNESIUM

NEON

NITROGEN

OXYGEN

POTASSIUM

SODIUM

Answer the questions.

Choose your answers from the list.

Each element can be used ONCE, MORE THAN ONCE or NOT AT ALL.

The Periodic Table on the back page may help you.

(a) (i) Write down the name of the element which has only 6 ELECTRONS in its outer shell.

_____ [1]

(ii) Write down the name of the element which has the electronic structure 2.8.8.1.

_____ [1]

(b) Look at the diagram.

It shows a helium atom.

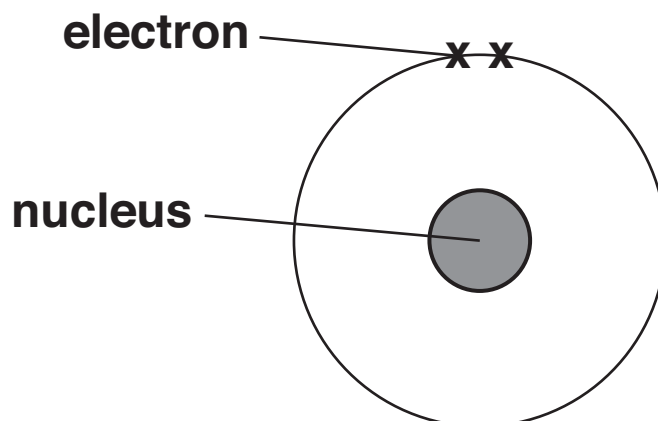

The table shows some information about the particles found in the nucleus of a helium atom.

COMPLETE the table.

<u>PARTICLE</u>	<u>RELATIVE MASS</u>	<u>RELATIVE CHARGE</u>
neutron	_____	_____
proton	1	+1

[2]

[Total: 4]

- 7 This question is about thermal decomposition.
Nick and Phil are heating some copper carbonate.
Look at the diagram. It shows the apparatus they use.

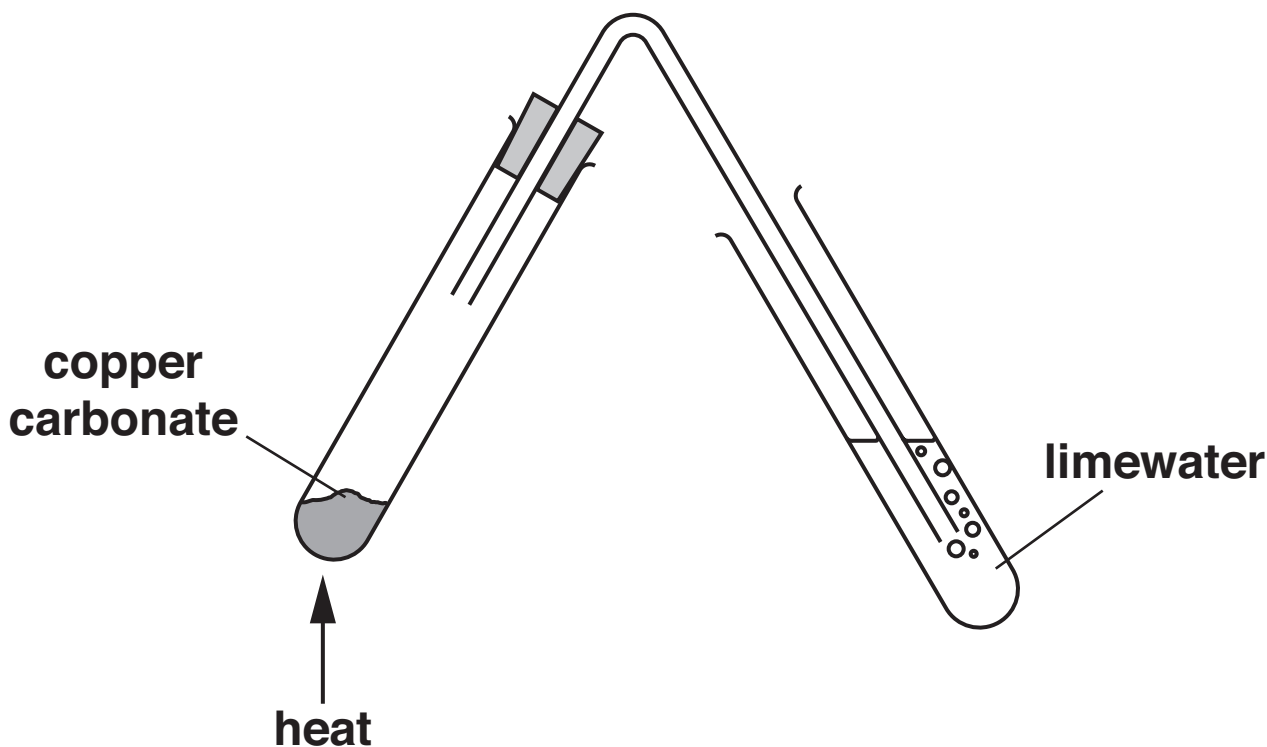

- (a) Copper carbonate decomposes when it is heated.
Copper oxide and carbon dioxide are made.

Write down the WORD equation for this reaction.

_____ [1]

- (b) Copper is a transition element.

Write down one property of a COMPOUND of a transition element.

_____ [1]

[Total: 2]

- 8 (a) Some metals become superconductors at very low temperatures.**

Superconductors conduct electricity with no loss of power.

Explain why.

_____ [1]

- (b) A train built in Japan can travel at over 500 km per hour.**

The train floats above a track.

This is possible by the use of superconductors.

- (i) The Japanese train is held above the track by magnetism.**

A superconductor uses a large current to make a powerful magnet.

Write down the name of this type of magnet.

answer _____ [1]

- (ii) These powerful magnets are an advantage of superconductors.

Write down ONE OTHER advantage and ONE disadvantage of using superconductors.

[2]

[Total: 4]

9 This question is about the halogens.

They are in Group 7 of the Periodic Table.

Look at the diagram. It shows an ATOM of chlorine.

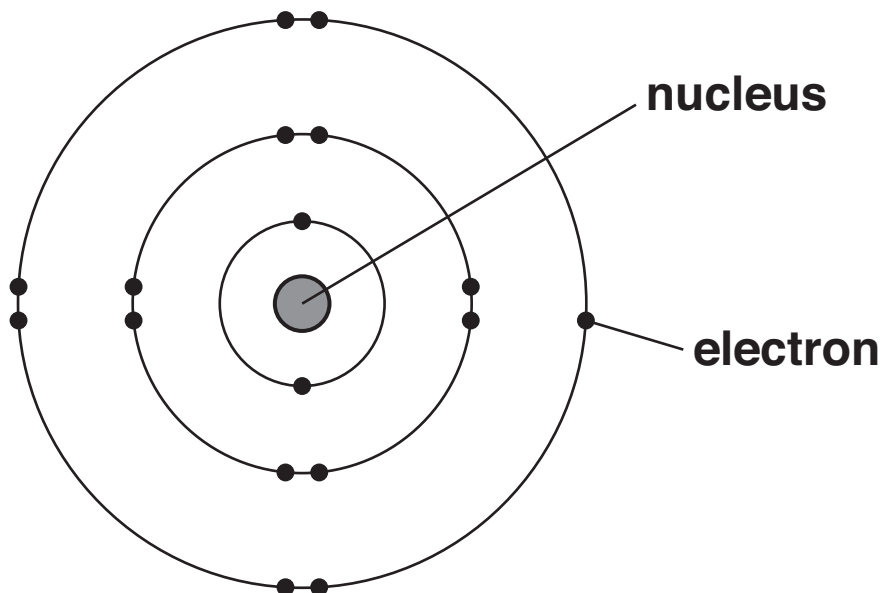

(a) The halogens have similar chemical properties.

Explain why. Use ideas about electronic structure.

[1]

(b) The atoms in a MOLECULE of chlorine, Cl_2 , are held together by a covalent bond.

Draw the 'dot and cross' diagram for a molecule of chlorine.

You only need to include the electrons in the outer shell of chlorine.

[2]

(c) Chlorine-35, ${}_{17}^{35}\text{Cl}$, and chlorine-37, ${}_{17}^{37}\text{Cl}$, are ISOTOPES of chlorine.

What is the difference between these two isotopes?

[1]

[Total: 4]

10 Sophie investigates passing an electric current through sodium chloride solution.

The diagram shows the apparatus she uses.

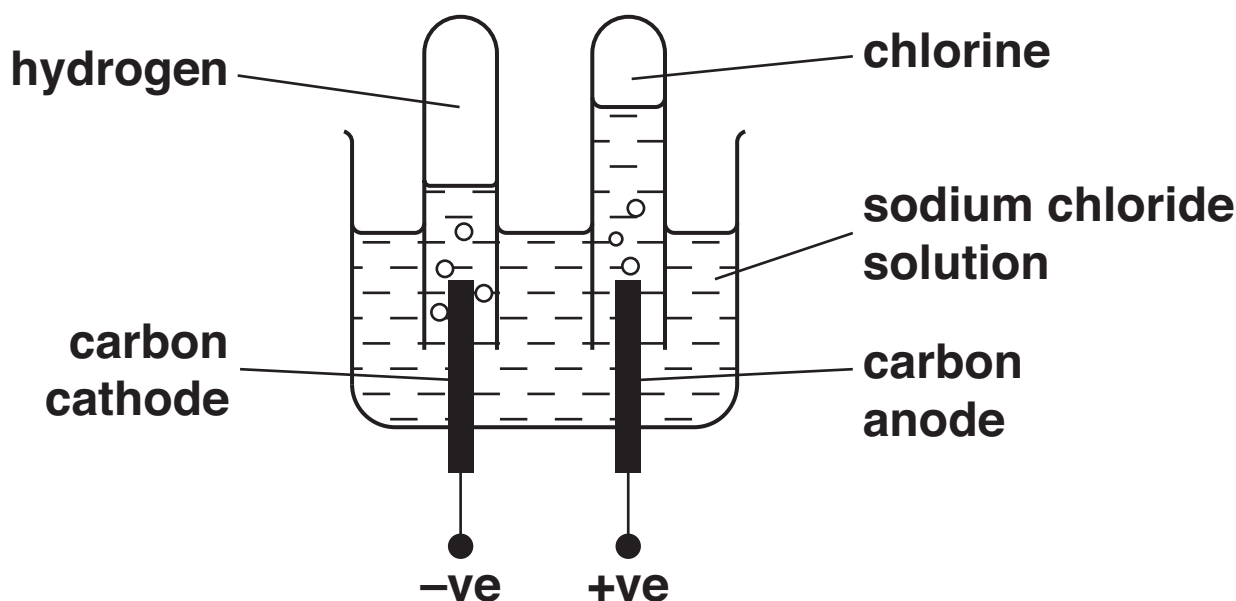

Look at the list. It shows the particles in the sodium chloride solution.

H^+ H_2O OH^- Cl^- Na^+

(a) Sophie finds that the solution conducts electricity.

Explain how a solution of sodium chloride conducts electricity.

_____ [1]

(b) Sodium atoms, Na, lose electrons to make sodium ions, Na^+ .

How many electrons does each sodium atom lose?

answer _____

[1]

(c) At the cathode hydrogen ions, H^+ , gain electrons to make hydrogen gas, H_2 .

Write down the EQUATION for the electrode reaction.

Use e^- to show an electron.

_____ [2]

[Total: 4]

11 This question is about oxidation and reduction.

Look at these equations.



(a) Which equation is an example of oxidation ONLY?

Choose A, B, C or D.

answer _____ [1]

(b) Which equation is NOT an example of an oxidation or reduction reaction?

Choose A, B, C or D.

answer _____ [1]

[Total: 2]

SECTION C – MODULE P3

12 This question is about gravitational potential energy.

(a) Look at the information in the table.

<u>PLANET</u>	<u>GRAVITATIONAL FIELD STRENGTH IN N/KG</u>
Earth	10
Jupiter	25
Mercury	4
Neptune	11
Pluto	1
Venus	9

Oliver calculates the gravitational potential energy for a 1 kg mass at a height of 2 m above the surface of each planet.

Where will the 1 kg mass have the greatest gravitational potential energy?

Choose from

Earth

Jupiter

Mercury

Neptune

Pluto

Venus

answer _____

[1]

(b) Look at the graph.

It shows how the potential energy of a roller coaster car changes as it moves along the track.

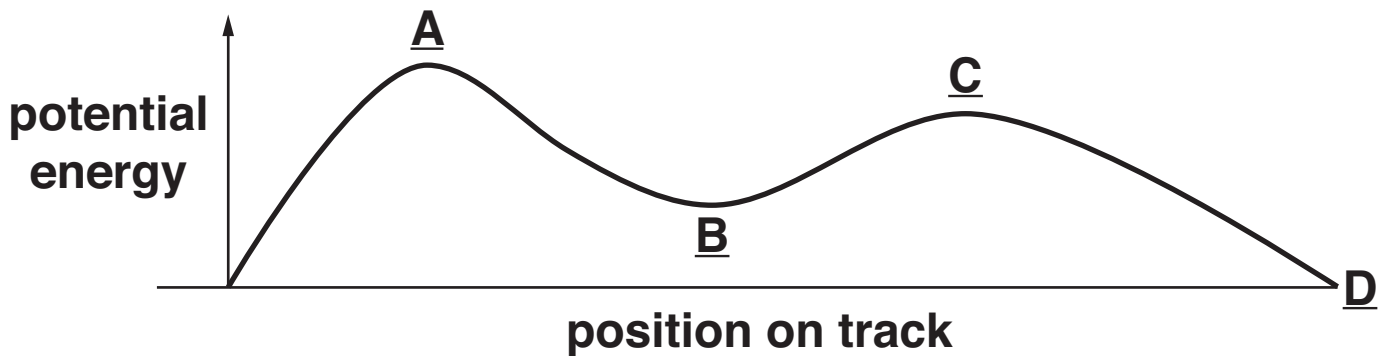

The car is pulled to the top of the roller coaster and starts with a speed of 0 m/s at point A.

Complete the table to show how the energy of the car changes as it moves along the track.

<u>POSITION ON TRACK</u>	<u>POTENTIAL ENERGY</u>	<u>KINETIC ENERGY</u>
<u>A</u> → <u>B</u>	decreases	
<u>B</u> → <u>C</u>		
<u>C</u> → <u>D</u>	decreases	increases

[2]

(c) Rosalind drops a ball from the edge of a cliff.

The ball will reach its terminal speed.

(i) Explain how the ball reaches its terminal speed.

In your answer, use ideas about

- forces**
- speed.**

[2]

(ii) At the terminal speed

- the kinetic energy of the ball is at its maximum**
- the potential energy of the ball is decreasing.**

What happens to this potential energy?

[1]

[Total: 6]

13 (a) There are large forces in a high speed crash.

Air bags change shape in a crash and absorb energy.

This reduces the forces on the driver.

Explain how air bags reduce the forces in a collision.

In your answer, use ideas about

- **speed**
- **acceleration**
- **time.**

[2]

(b) Some safety devices make driving safer.

They do not reduce injury in a crash.

Adjustable seating is one of these safety devices.

Explain how this makes driving safer.

[1]

- (c) Drivers who have been drinking alcohol are more likely to have accidents.

This is because their reaction time and thinking distance have increased.

Write down one OTHER factor that can increase thinking distance.

_____ [1]

- (d) Braking distance increases in certain conditions.

Write down ONE factor that can increase braking distance.

_____ [1]

[Total: 5]

14 Penny drives her car up a hill.

(a) Look at the diagram.

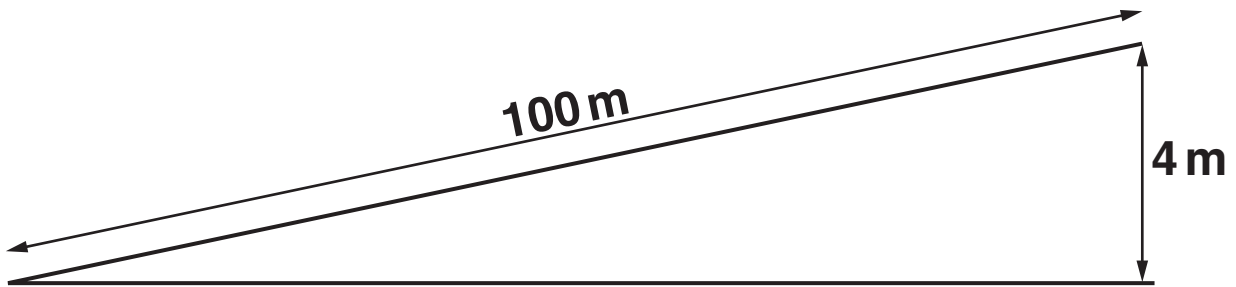

Her car climbs 4 m for every 100 m that it moves along the road.

The car weighs 7000 N.

(i) Show that the work done is 28 000 J.

The equations on page 3 may help you.

[1]

(ii) It takes 8 seconds to do 28 000 J of work.

Calculate the power the engine needs to climb the hill.

The equations on page 3 may help you.

answer _____ W [2]

(b) (i) Look at the graph.

It shows how the driving force produced by Penny's car engine increases with speed.

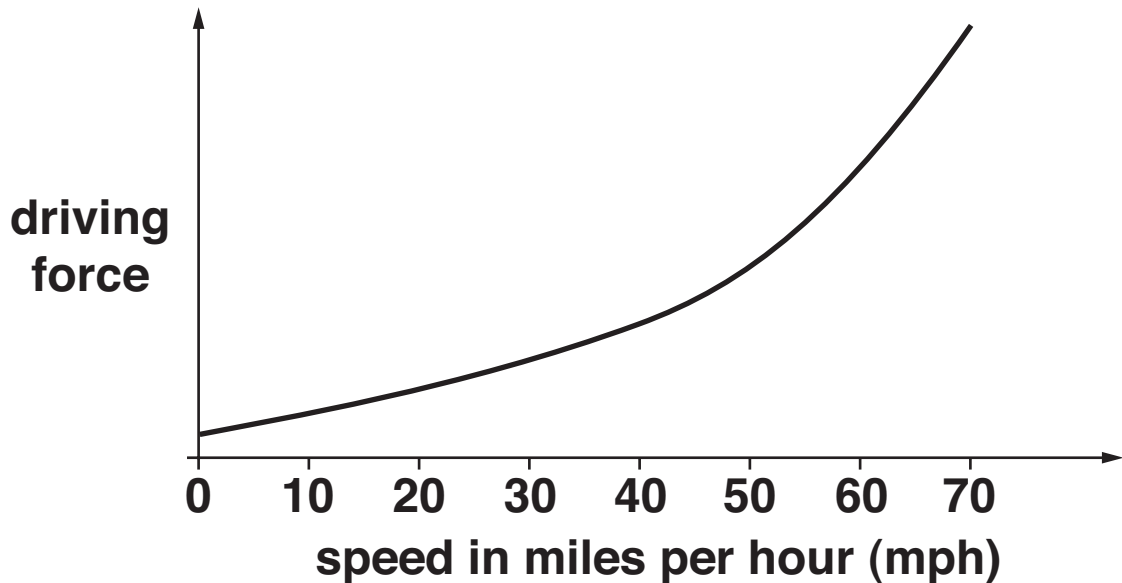

The fuel consumption at 70 mph is MUCH larger than Penny expected.

Use the graph to explain why.

[1]

(ii) Apart from speed, write down one OTHER factor that affects fuel consumption in Penny's car.

[1]

(c) Penny is concerned about polluting the environment.

She is thinking of buying an electrically powered car.

The salesman says that it does NOT cause pollution.

Is he really correct?

Explain your answer.

[2]

[Total: 7]

BLANK PAGE

15 This question is about motion.

The diagram opposite shows speed-time graphs in the first column.

There is a list of statements in the second column.

Draw a straight line to join each SPEED-TIME GRAPH with its correct STATEMENT. [2]

[Total: 2]

END OF QUESTION PAPER

SPEED-TIME GRAPH

STATEMENT

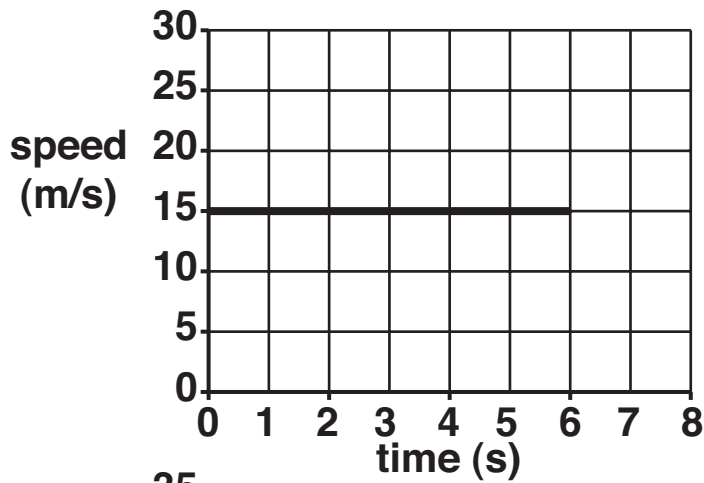

accelerates at
 5 m / s^2

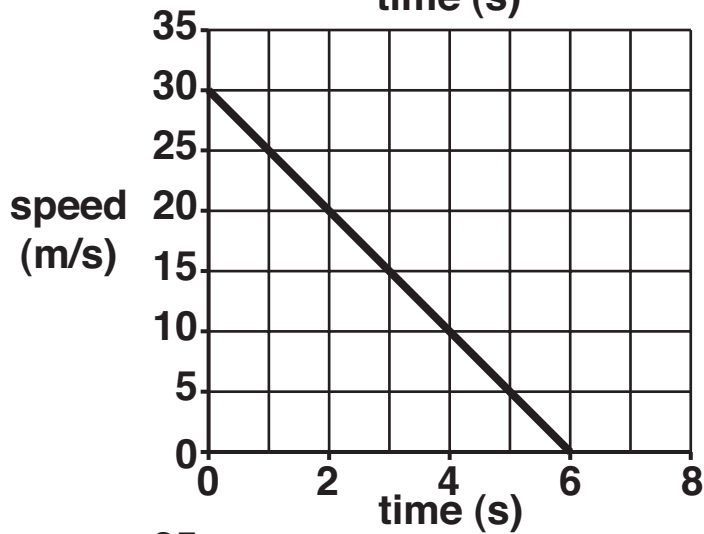

is travelling at a
steady speed

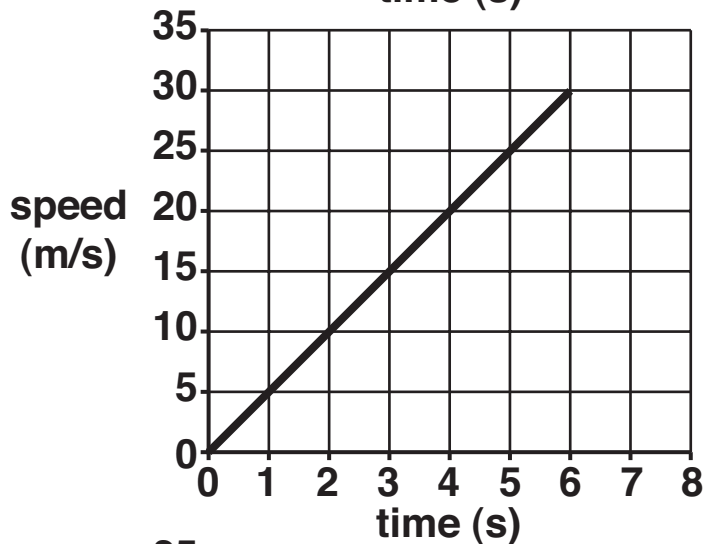

travels 50 m in the
first 2 seconds

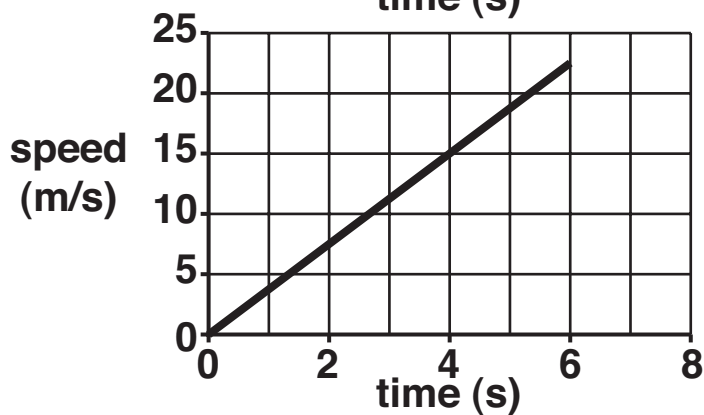

travels 30 m in the
first 4 seconds

BLANK PAGE



Copyright Information

OCR is committed to seeking permission to reproduce all third-party content that it uses in its assessment materials. OCR has attempted to identify and contact all copyright holders whose work is used in this paper. To avoid the issue of disclosure of answer-related information to candidates, all copyright acknowledgements are reproduced in the OCR Copyright Acknowledgements Booklet. This is produced for each series of examinations, is given to all schools that receive assessment material and is freely available to download from our public website (www.ocr.org.uk) after the live examination series.

If OCR has unwittingly failed to correctly acknowledge or clear any third-party content in this assessment material, OCR will be happy to correct its mistake at the earliest possible opportunity.

For queries or further information please contact the Copyright Team, First Floor, 9 Hills Road, Cambridge CB2 1PB.

OCR is part of the Cambridge Assessment Group; Cambridge Assessment is the brand name of University of Cambridge Local Examinations Syndicate (UCLES), which is itself a department of the University of Cambridge.

