

**GENERAL CERTIFICATE OF SECONDARY EDUCATION
GATEWAY SCIENCE
ADDITIONAL SCIENCE B**

B624/01

Unit 2 Modules B4 C4 P4
(Foundation Tier)

**Wednesday 21 January 2009
Afternoon**

Duration: 1 hour

Candidates answer on the question paper
A calculator may be used for this paper

OCR Supplied Materials:
None

Other Materials Required:

- Pencil
- Ruler (cm/mm)



Candidate Forename		Candidate Surname	
--------------------	--	-------------------	--

Centre Number						Candidate Number				
---------------	--	--	--	--	--	------------------	--	--	--	--

INSTRUCTIONS TO CANDIDATES

- Write your name clearly in capital letters, your Centre Number and Candidate Number in the boxes above.
- Use black ink. Pencil may be used for graphs and diagrams only.
- Read each question carefully and make sure that you know what you have to do before starting your answer.
- Answer **all** the questions.
- Do **not** write in the bar codes.
- Write your answer to each question in the space provided, however additional paper may be used if necessary.

INFORMATION FOR CANDIDATES

- The number of marks is given in brackets [] at the end of each question or part question.
- A list of physics equations is printed on page two.
- The Periodic Table is printed on the back page.
- The total number of marks for this paper is **60**.
- This document consists of **20** pages. Any blank pages are indicated.

FOR EXAMINER'S USE		
Section	Max.	Mark
A	20	
B	20	
C	20	
TOTAL	60	

EQUATIONS

$$\text{speed} = \frac{\text{distance}}{\text{time taken}}$$

$$\text{acceleration} = \frac{\text{change in speed}}{\text{time taken}}$$

$$\text{force} = \text{mass} \times \text{acceleration}$$

$$\text{work done} = \text{force} \times \text{distance}$$

$$\text{power} = \frac{\text{work done}}{\text{time}}$$

$$\text{resistance} = \frac{\text{voltage}}{\text{current}}$$

BLANK PAGE

Question 1 begins on page 4.

PLEASE DO NOT WRITE ON THIS PAGE

Answer **all** the questions.

Section A – Module B4

1 Percy builds a compost heap in his garden.

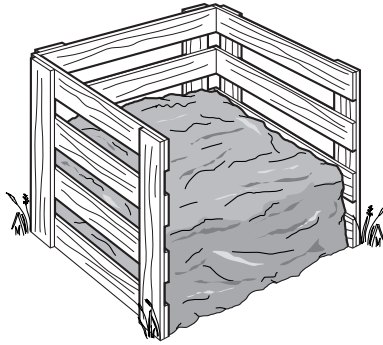

(a) Percy wants to put different waste materials on his compost heap.

Put a **ring** around any materials that will **not** easily decay on his compost heap.

apples

cooking foil

dead flowers

glass bottles

potato peelings

[2]

(b) Percy buys a box of compost maker to make the waste decay faster.



Why does the compost maker help to make the waste decay faster?

..... [1]

[Total: 3]

2 The diagram shows a plant.

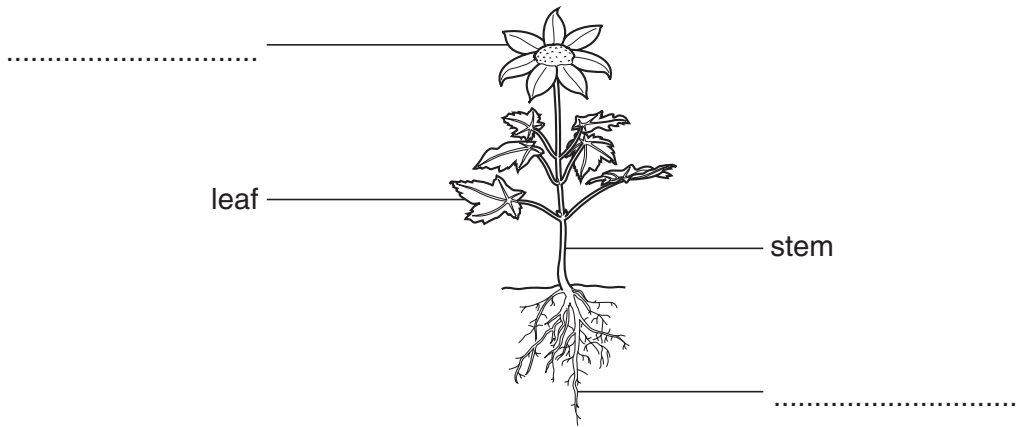

(a) Finish the diagram by writing in the **two** missing labels. [2]

(b) Mohindra is doing an experiment using a plant in a pot.

He puts it on a balance to measure its mass.

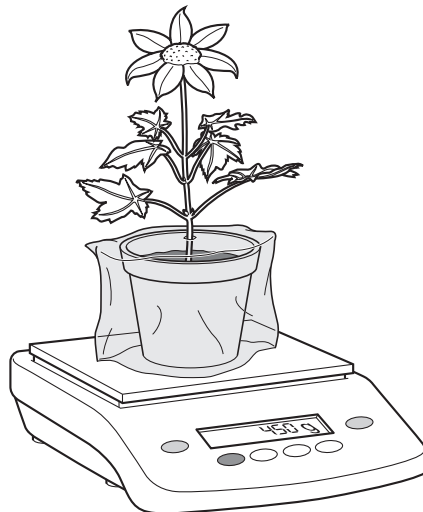

After two days he finds that the plant has lost mass.

He decides that this is due to the loss of water from the plant.

Finish these sentences about this loss of water.

Most water is lost from the of the plant.

This loss of water is affected by light, wind and

[2]

[Total: 4]

3 This question is about bananas.

(a) Banana plants are grown in large fields called plantations.

They are part of a food web.

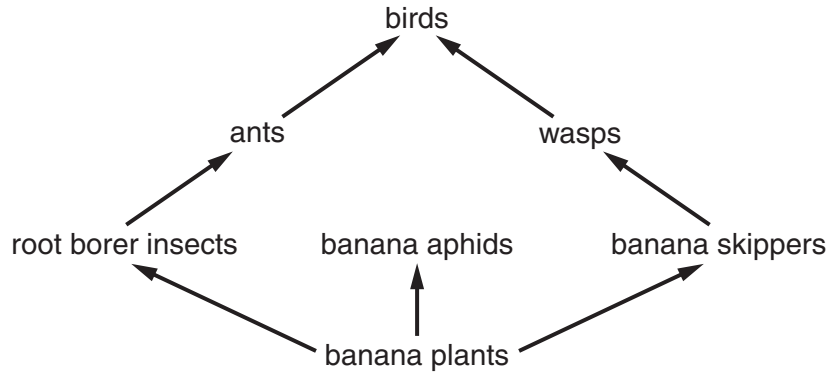

(i) The banana plants are **producers** for this food web.

What is meant by the term producer?

.....
 [1]

(ii) What is the source of energy for this food web?

..... [1]

(b) The diagram shows the shape of a pyramid of numbers for this food web.

pyramid of numbers

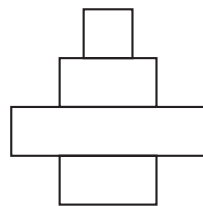

pyramid of biomass

Describe how a pyramid of biomass would look different to this pyramid of numbers.

You may draw a diagram in the space above if you wish.

.....
 [1]

(c) Some banana farmers use pesticides to kill insect pests.

Explain why farmers want to kill insect pests.

.....
..... [2]

(d) People who live near the plantations are worried that the pesticides might be harming them.

Look at this graph.

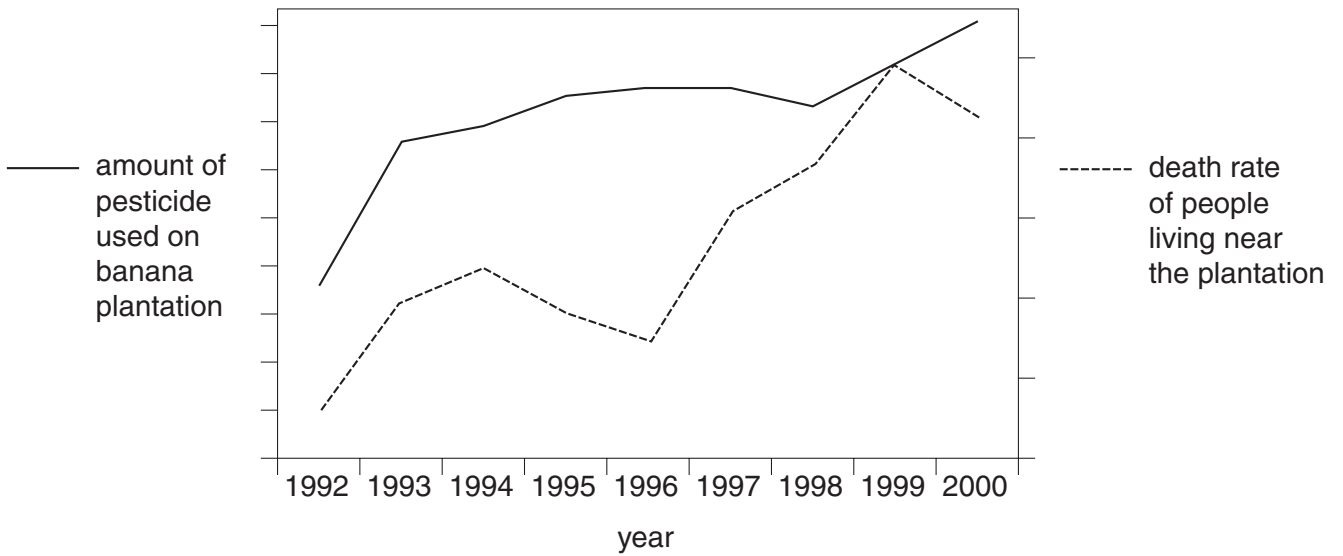

(i) How does the graph suggest that the people might be correct?

.....
..... [1]

(ii) Some farmers decide not to use pesticides.

They use biological control instead.

Biological control will not harm people.

Explain one **other** advantage of using biological control instead of pesticides.

.....
..... [1]

[Total: 7]

4 The diagram shows a plant cell from a root.

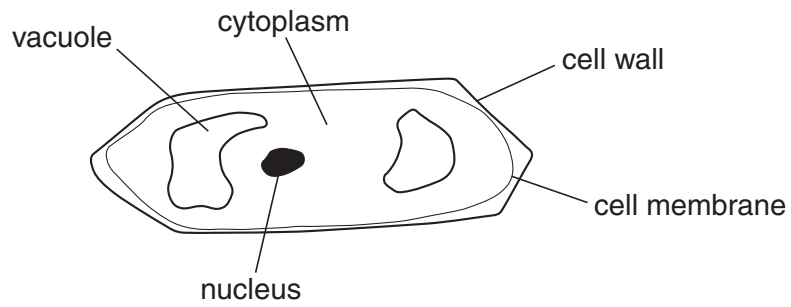

(a) The cell is placed in a dilute solution.

Water moves from the solution into the vacuole.

Write the parts of the cell into the correct boxes to show the direction water moves.



[2]

(b) The cell membrane is partially permeable.

What is meant by the term **partially permeable**?

.....

..... [1]

[Total: 3]

5 The diagram shows the carbon cycle.

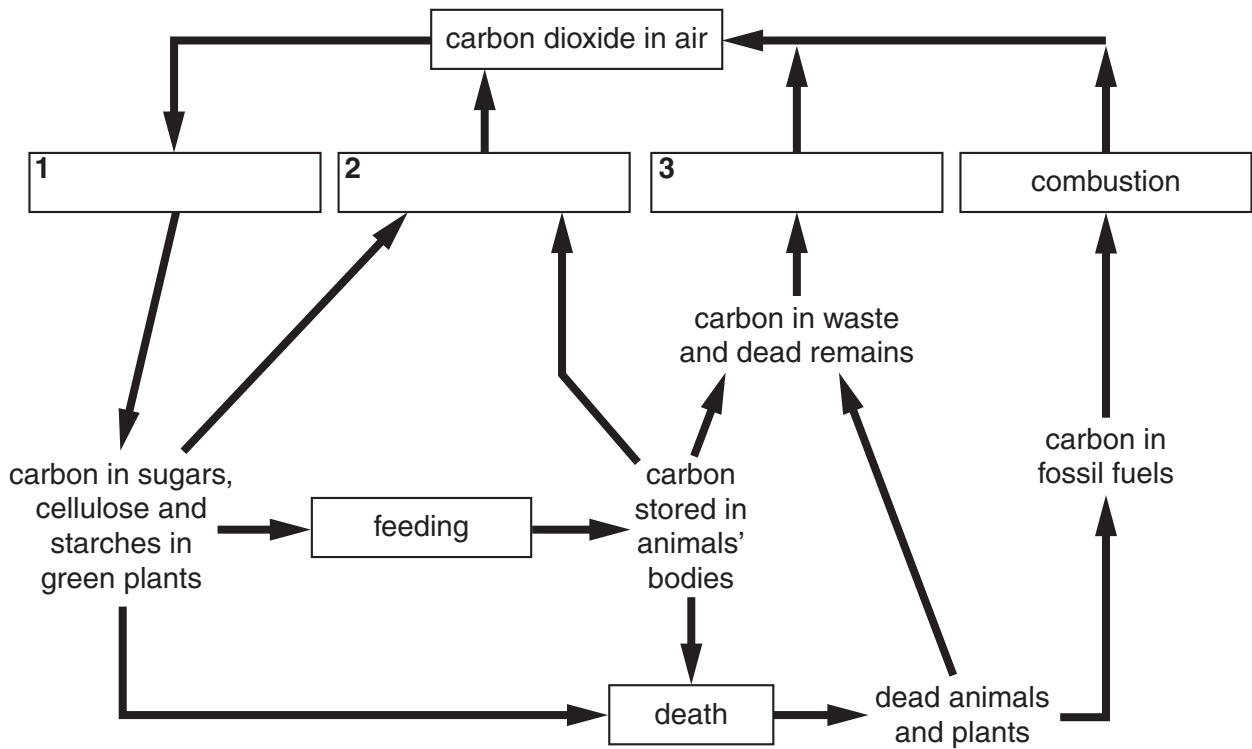

(a) Finish the diagram by writing the best words in the boxes 1, 2 and 3.

Choose your words from this list.

decomposition

photosynthesis

respiration

[2]

(b) Write down **one other** element important to living organisms that needs to be recycled in nature.

..... [1]

[Total: 3]

Section B – Module C4

6 This question is about acids and bases.

(a) The pH scale shows how acidic or alkaline a substance is.

1	2	3	4	5	6	7	8	9	10	11	12	13	14
red							green			blue			

Look at the list.

acidic

alkaline

base

carbonate

neutral

Complete these sentences.

Use words from the list.

(i) Solutions with a pH of 7 are [1]

(ii) Solutions with a pH of **less** than 7 are [1]

(b) An acid reacts with a carbonate.

A salt and water are made.

A gas is also made.

Write down the name of the gas.

Choose from the list.

ammonia

carbon dioxide

hydrogen

nitrogen

oxygen

answer [1]

(c) John makes some sodium chloride.

He uses sodium hydroxide and an acid.

Write down the name of the acid.

Choose from the list.

hydrochloric acid

nitric acid

phosphoric acid

sulfuric acid

answer [1]

(d) Write down **one** large scale use of sulfuric acid.

..... [1]

[Total: 5]

7 This question is about the Haber process and ammonia.

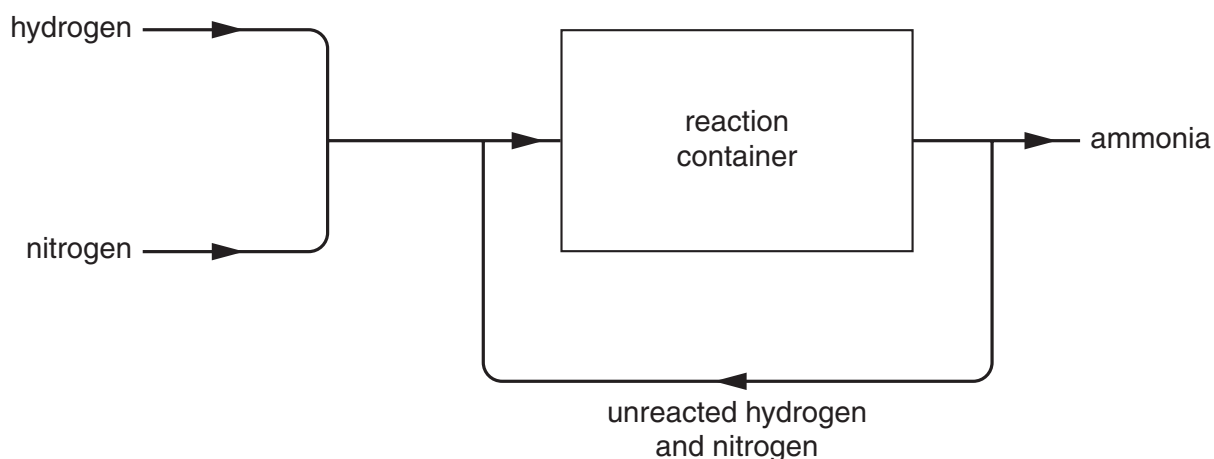

(a) Ammonia is made by reacting nitrogen and hydrogen together.

(i) Write down where the nitrogen comes from.

..... [1]

(ii) Write down where the hydrogen comes from.

..... [1]

(b) The word equation for this reaction is



What does the symbol \rightleftharpoons mean?

..... [1]

(c) The cost of making ammonia is affected by many factors.

One factor is the cost of the starting materials.

Write about **other** factors that affect the cost of making ammonia.

.....

 [2]

[Total: 5]

8 This question is about forms of carbon.

Carbon occurs in three forms.

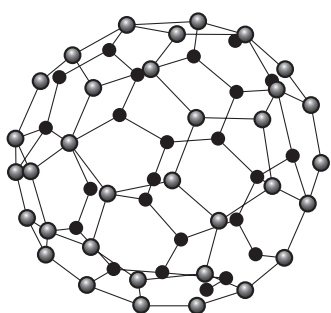

buckminster fullerene

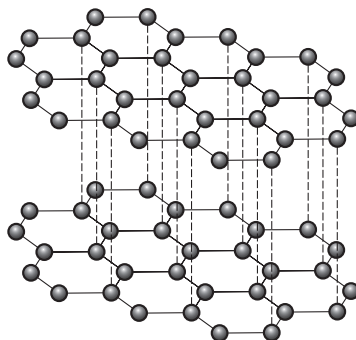

graphite

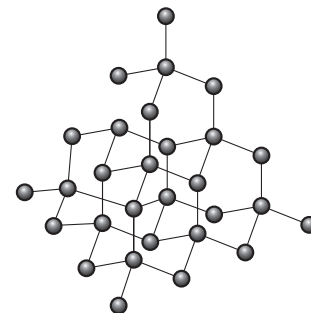

(a) Buckminster fullerene and graphite are two forms.

Write down the name of the **other** form.

..... [1]

(b) Some properties of graphite are

- it is shiny
- it is insoluble in water.

Write down **two other** properties of graphite.

1

2 [2]

(c) (i) Buckminster fullerene is made from a large number of carbon atoms.

What is its formula? Choose from the list.

C₄₀

C₆₀

C₈₀

C₁₀₀

answer [1]

(ii) Fullerenes can be made into nanotubes.

Write down **one** use of nanotubes.

..... [1]

[Total: 5]

Turn over

9 This question is about potassium nitrate, KNO_3 .

(a) (i) Write down the number of different **elements** in the formula KNO_3 .

..... [1]

(ii) Write down the total number of **atoms** in the formula KNO_3 .

..... [1]

(b) Calculate the relative formula mass of potassium nitrate.

The relative atomic mass of K = 39, of N = 14, and of O = 16.

answer [1]

(c) Paul makes some potassium nitrate, KNO_3 .

He expects to make 6.0 g of potassium nitrate.

He actually makes 4.8 g.

Calculate his percentage yield.

.....
.....
.....

answer % [2]

[Total: 5]

Section C – Module P4

10 Jamie walks across a vinyl kitchen floor.

He turns on the water tap and gets an **electrostatic** shock.

(a) Put ticks (✓) in the boxes next to **three** statements that help to explain why he gets an electrostatic shock.

A direct current is passing through the water pipes.

An alternating current is passing through the water pipes.

Jamie becomes charged.

The vinyl floor is a conductor.

The vinyl floor is an insulator.

The water pipes are connected to the earth wire of the domestic electricity supply.

The water pipes are connected to the live wire of the domestic electricity supply.

[3]

(b) Jamie rubs a plastic rod with a piece of silk.

The teacher tells him that the plastic has become positively charged.

(i) What is the charge on the silk?

..... [1]

(ii) Jamie holds the rod near to a stream of water from the tap.

The water moves towards the rod.

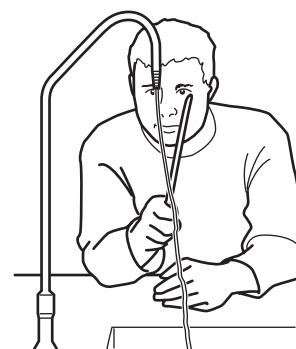

Suggest a reason why.

..... [1]

[Total: 5]

11 Mandy buys an electric drill at a car boot sale.

It has this symbol on it.

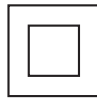

This means the drill is **double insulated**.

Mandy checks the wiring of its plug.

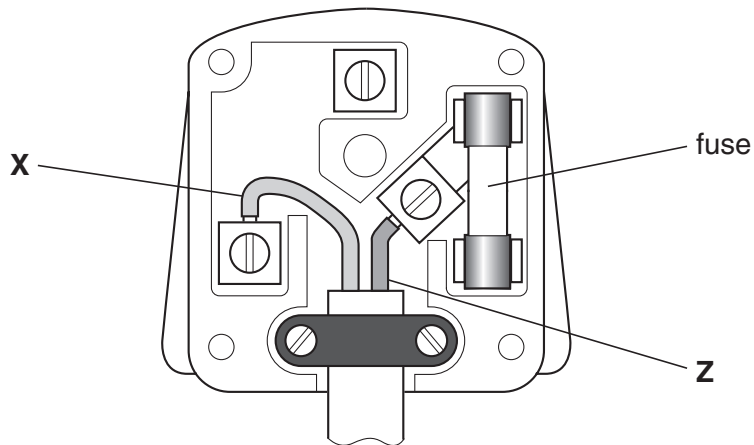

(a) Write down the **colour** of wire **X**. [1]

(b) Write down the **colour** of wire **Z**. [1]

(c) There are usually three wires in a plug.

Which wire is not needed for a **double insulated** electric drill?

..... [1]

(d) The plug has a fuse in it for safety.

Describe how the fuse works.

.....
..... [2]

[Total: 5]

12 Trevor has broken his arm.

He has it X-rayed at the hospital.

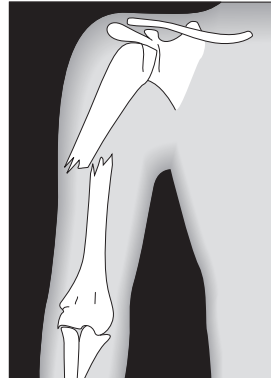

(a) Who took the X-ray of Trevor's broken arm?

Put a **ring** around the correct answer.

astronomer

photographer

radiographer

stenographer

[1]

(b) X-rays are electromagnetic waves.

Write down one **other** example of an electromagnetic wave used in hospital.

..... [1]

(c) Electromagnetic waves are transverse waves.

Ultrasound is not an electromagnetic wave.

(i) What type of wave is ultrasound?

..... [1]

(ii) Describe two **different** uses of ultrasound in hospital.

1

2 [2]

[Total: 5]

13 Hinkley Point is a nuclear power station.



© Skyscan/Science Photo Library

(a) What is the source of energy at Hinkley Point?

Put a ring around the correct answer.

coal

gas

oil

oxygen

uranium

[1]

(b) What can happen to materials when they are put inside the core of a nuclear reactor?

..... [1]

(c) Electricity is generated in a **nuclear** power station.

(i) How is heat produced in the nuclear power station?

..... [1]

(ii) How is this heat used?

..... [1]

(iii) What makes the generator turn?

..... [1]

[Total: 5]

END OF QUESTION PAPER

PLEASE DO NOT WRITE ON THIS PAGE



Acknowledgements:

Question 13

© Skyscan/Science Photo Library

Permission to reproduce items where third-party owned material protected by copyright is included has been sought and cleared where possible. Every reasonable effort has been made by the publisher (OCR) to trace copyright holders, but if any items requiring clearance have unwittingly been included, the publisher will be pleased to make amends at the earliest possible opportunity.

OCR is part of the Cambridge Assessment Group. Cambridge Assessment is the brand name of University of Cambridge Local Examinations Syndicate (UCLES), which is itself a department of the University of Cambridge.

