

**GENERAL CERTIFICATE OF SECONDARY EDUCATION
TWENTY FIRST CENTURY SCIENCE
ADDITIONAL SCIENCE A**

A215/01

Unit 1: Modules B4 C4 P4 (Foundation Tier)

Candidates answer on the Question Paper
A calculator may be used for this paper

OCR Supplied Materials:
None

Other Materials Required:

- Pencil
- Ruler (cm/mm)

**Monday 25 January 2010
Afternoon**

Duration: 40 minutes



Candidate Forename		Candidate Surname	
--------------------	--	-------------------	--

Centre Number						Candidate Number				
---------------	--	--	--	--	--	------------------	--	--	--	--

INSTRUCTIONS TO CANDIDATES

- Write your name clearly in capital letters, your Centre Number and Candidate Number in the boxes above.
- Use black ink. Pencil may be used for graphs and diagrams only.
- Read each question carefully and make sure that you know what you have to do before starting your answer.
- Answer **all** the questions.
- Do **not** write in the bar codes.
- Write your answer to each question in the space provided, however additional paper may be used if necessary.

INFORMATION FOR CANDIDATES

- The number of marks is given in brackets [] at the end of each question or part question.
- The total number of marks for this paper is **42**.
- A list of physics equations is printed on page 2.
- The Periodic Table is printed on the back page.
- This document consists of **16** pages. Any blank pages are indicated.

TWENTY FIRST CENTURY SCIENCE EQUATIONS

Useful Relationships

Explaining Motion

$$\text{speed} = \frac{\text{distance travelled}}{\text{time taken}}$$

$$\text{momentum} = \text{mass} \times \text{velocity}$$

$$\text{change of momentum} = \text{resultant force} \times \text{time for which it acts}$$

$$\text{work done by a force} = \text{force} \times \text{distance moved by the force}$$

$$\text{change in energy} = \text{work done}$$

$$\text{change in GPE} = \text{weight} \times \text{vertical height difference}$$

$$\text{kinetic energy} = \frac{1}{2} \times \text{mass} \times [\text{velocity}]^2$$

Electric Circuits

$$\text{resistance} = \frac{\text{voltage}}{\text{current}}$$

$$\frac{\text{voltage across primary coil}}{\text{voltage across secondary coil}} = \frac{\text{number of turns in primary coil}}{\text{number of turns in secondary coil}}$$

$$\text{energy transferred} = \text{power} \times \text{time}$$

$$\text{power} = \text{potential difference} \times \text{current}$$

$$\text{efficiency} = \frac{\text{energy usefully transferred}}{\text{total energy supplied}} \times 100\%$$

The Wave Model of Radiation

$$\text{wave speed} = \text{frequency} \times \text{wavelength}$$

Answer **all** the questions.

1 Sue is a doctor.

She treats patients for either heat stroke or hypothermia at different times of the year.

(a) Draw straight lines from each **symptom** to the correct **condition**.

Draw straight lines from each **treatment** to the correct **condition**.

symptom	condition	treatment
rapid pulse rate	hypothermia	wrap in wet towels
shivering		insulate the patient
slurred speech	heat stroke	keep the patient as still as possible
dry skin		use a fan

[4]

(b) (i) Sue takes the temperature of a patient suffering from **heat stroke**.

Put a **ring** around the temperature she is most likely to find.

34 °C

37 °C

40 °C

[1]

(ii) Sue takes the temperature of a patient suffering from **hypothermia**.

Put a **ring** around the temperature she is most likely to find.

34 °C

36 °C

38 °C

40 °C

42 °C

[1]

[Total: 6]

2 Barry sets up an experiment to investigate osmosis.

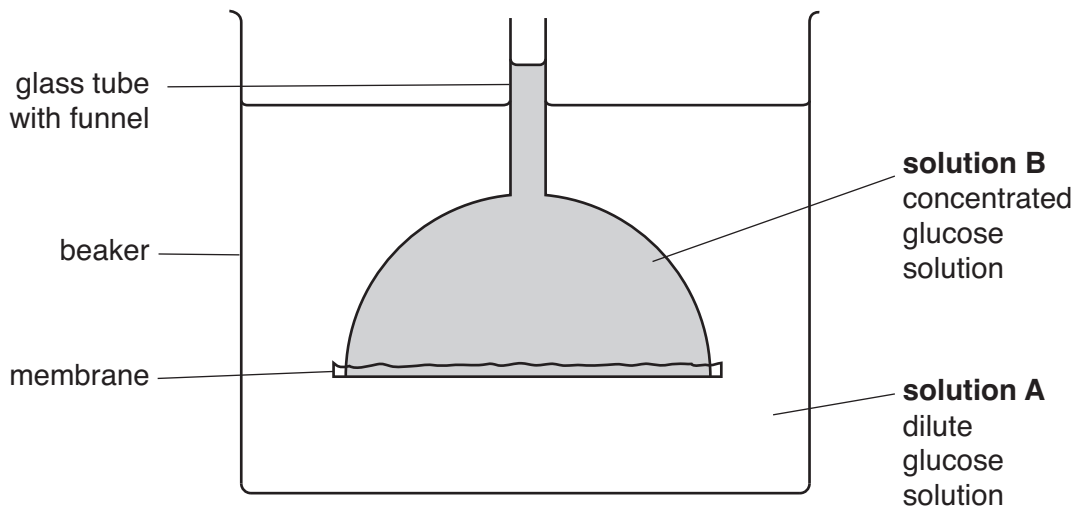

(a) What type of membrane should Barry use to investigate osmosis?

..... [1]

(b) Barry sees that the level in the tube goes up.

Put a tick (✓) in the box next to the correct reason.

only water moves from **solution A** to **solution B**

only glucose moves from **solution A** to **solution B**

both water and glucose move from **solution A** to **solution B**

[1]

(c) Barry repeats the experiment. He wants to change his experiment so that the level in the tube does not change.

What should he do?

Put a tick (✓) in the box next to the correct answer.

add more water to **solution A**

add more glucose to **solution A**

warm up **solution A**

[1]

[Total: 3]

- 3** Tina investigates the effect of temperature on enzymes. She uses the enzyme catalase to break down hydrogen peroxide. She collects the oxygen gas given off by the reaction. Here are some of her results.

temperature of catalase and hydrogen peroxide in °C	volume of gas collected in 1 minute in cm ³
20	18
30	36
40	40
90	

- (a)** Suggest and explain how much gas will be produced at 90 °C.

.....

 [2]

- (b)** Tina tries to use a different enzyme to break down hydrogen peroxide.

Use the lock and key model to explain why this will not work.

.....

 [3]

[Total: 5]

4 Atoms are made up of protons, neutrons and electrons.

(a) The charge and the mass of protons, neutrons and electrons are not the same.

Draw straight lines to join each type of **particle** to its **charge**.

Draw straight lines to join each type of **particle** to its **relative mass**.

charge	particle	relative mass
0	proton	almost zero
-1	neutron	1
+1	electron	

[2]

(b) Many chemical changes involve ions.

Draw **one** line between the two boxes which **best** describe what an ion is.

A crystal lattice which has gained or lost electrons.
or	or
A group of atoms which has gained or lost protons.
or	or
An atom or a group of atoms which has gained or lost neutrons.
or	or
An atom which has moved from one group to another.

[2]

[Total: 4]

5 David's teacher does an experiment using sodium.

- (a) The sodium is stored in a bottle of oil.
Why must it be stored in oil?

.....

 [2]

- (b) Sodium is in group 1 of the Periodic Table.
Here is an outline of the Periodic Table.
The cross (X) shows one of the group 1 metals.

Put crosses (X) in **two more** boxes that are group 1 metals.

X								

[1]

- (c) The teacher puts a small piece of sodium into a beaker of water.

State two things you would **see** happen in the beaker.

.....

 [2]

- (d) David watches a firework display. He suspects that a firework contains sodium compounds.
What is the clue that makes him suspect this?

Put a tick (✓) in the box next to the **best** answer.

- The firework burns rapidly.
- The firework makes a strong smell.
- The firework produces grey smoke.
- The firework burns with a yellow flame.

[1]

[Total: 6]

6 Bromine is a toxic and corrosive liquid.

(a) Which two safety symbols should be on bottles of bromine?

Put a **ring** around each of the **two** correct labels.



[1]

(b) The symbol for a bromine molecule is Br₂.

Which of these diagrams could be of a bromine molecule?

Put a **ring** around the correct answer.



[1]

(c) Bromine reacts with sodium to make sodium bromide.

Use the spaces to write a word equation for this reaction.



[1]

(d) Solid sodium bromide is ionic.

Draw **one** line between the boxes to describe what happens to the ions when solid sodium bromide dissolves in water.

Ions are in the solid at the start.

Ions then spread through the liquid.

or

or

Ions form when the solid dissolves.

Ions then sink to the bottom of the liquid.

[1]

[Total: 4]

7 Joe drives a bus along a level road.

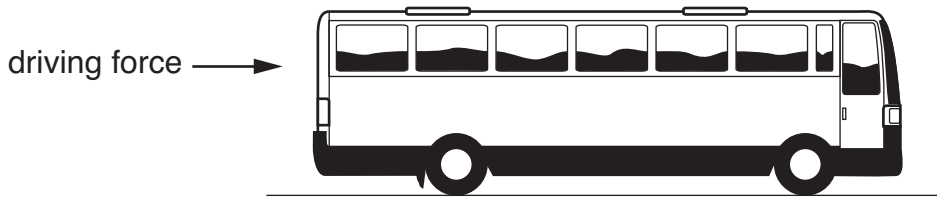

(a) A driving force acts forwards on the bus when it is moving at a steady speed.

Explain why the driving force does not increase the speed of the bus.

.....

.....

..... [2]

(b) On the axes below, sketch a **distance-time** graph for the bus as it travels at a steady speed of 15 m/s.

Start the graph at the point 0,0.

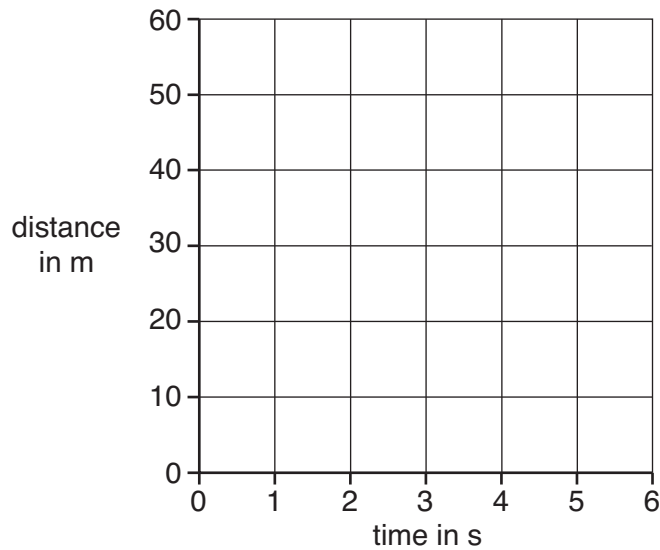

[2]

[Total: 4]

- 8 A small jet aircraft is speeding up along a runway.



- (a) The engines exert a force of 6000 N on the aircraft as it moves along the runway. Which calculation shows the change of momentum of the aircraft in 12 s?

Put a ring around the correct answer.

$$\frac{6000}{12}$$

$$6000 \times 12$$

$$\frac{12}{6000}$$

[1]

- (b) Put a ring around the correct choice in each sentence.

The jet engines increase the forward speed of the aircraft.

The engines do this by pushing gas **backwards** / **forwards**.

The force needed on the gas is in the **backwards** / **forwards** direction.

This results in a force on the engines in the **same** / **opposite** direction.

The force on the engines is **greater than** / **the same as** / **smaller than** the force on the gas.

[2]

(c) Which of these **velocity-time** graphs shows a steadily increasing velocity?

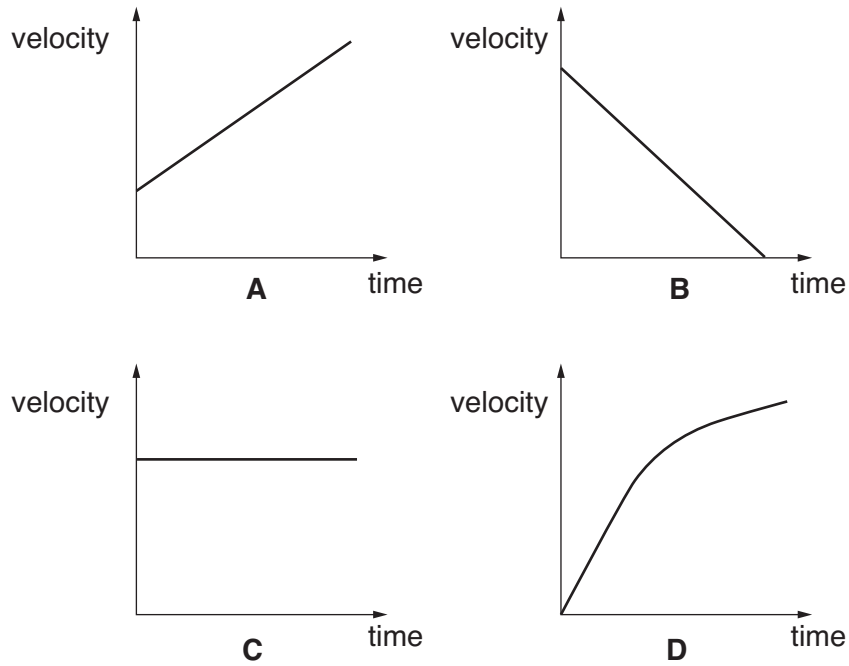

answer [1]

(d) The aircraft takes off when it has a forward velocity of 48 m/s.

Put a tick (✓) in the box next to the correct meaning of the word **velocity**.

The velocity of an object is ...

... how fast its speed is changing.

... its speed and direction of motion.

... how fast its direction is changing.

[1]

[Total: 5]

9 Jim takes part in a high jump contest.

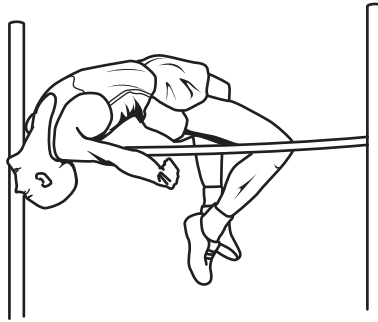

(a) Complete the sentences.

Choose words from this list.

gravitational potential

kinetic

momentum

work

Jim stands 10m away from the high jump.

He runs towards the high jump, gaining energy.

He then jumps up to the bar, gaining energy.

[2]

(b) Jim has a mass of 65 kg. Just before he jumps up, his velocity is 10 m/s.

Who has the correct way of calculating his momentum?

 <p>Alan $\frac{1}{2} \times 65 \times 10^2$</p>	 <p>Bess $65 \times 10 \times 10$</p>
	
	
 <p>Carlos 65×10</p>	 <p>Davina $\frac{1}{2} \times 65 \times 10$</p>

answer [1]

(c) Jim clears the bar and falls back to the ground.

Put a (ring) around the correct **velocity-time** graph for Jim as he falls vertically to the ground.

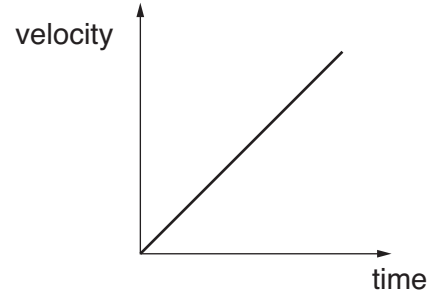
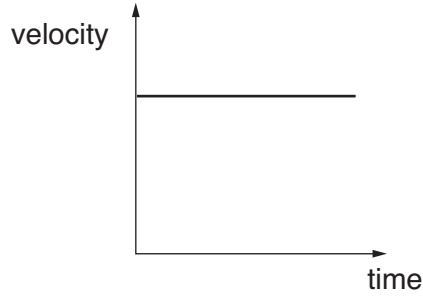
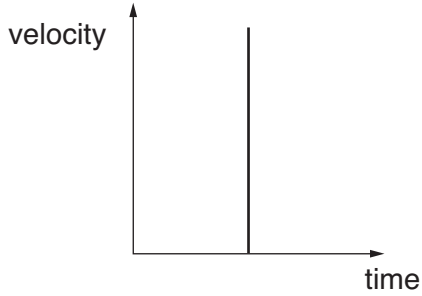

[1]

(d) Jim stops moving when he lands.

Put a tick (✓) in the box next to the correct statement.

His kinetic energy is lost through heating.

He gains momentum through friction.

He loses weight through reaction.

[1]

[Total: 5]

END OF QUESTION PAPER

PLEASE DO NOT WRITE ON THIS PAGE



Copyright Information

OCR is committed to seeking permission to reproduce all third-party content that it uses in its assessment materials. OCR has attempted to identify and contact all copyright holders whose work is used in this paper. To avoid the issue of disclosure of answer-related information to candidates, all copyright acknowledgements are reproduced in the OCR Copyright Acknowledgements Booklet. This is produced for each series of examinations, is given to all schools that receive assessment material and is freely available to download from our public website (www.ocr.org.uk) after the live examination series.

If OCR has unwittingly failed to correctly acknowledge or clear any third-party content in this assessment material, OCR will be happy to correct its mistake at the earliest possible opportunity.

For queries or further information please contact the Copyright Team, First Floor, 9 Hills Road, Cambridge CB2 1GE.

OCR is part of the Cambridge Assessment Group; Cambridge Assessment is the brand name of University of Cambridge Local Examinations Syndicate (UCLES), which is itself a department of the University of Cambridge.

The Periodic Table of the Elements

	1	2	3	4	5	6	7	0	
	7 Li lithium 3	9 Be beryllium 4	11 Na sodium 11	12 C carbon 6	13 Al aluminium 13	14 N nitrogen 7	15 O oxygen 8	16 F fluorine 9	17 Ne neon 10
	19 K potassium 19	20 Ca calcium 20	23 V vanadium 23	24 Cr chromium 24	25 Mn manganese 25	26 Fe iron 26	27 Co cobalt 27	28 Ni nickel 28	29 Cu copper 29
	37 Rb rubidium 37	38 Sr strontium 38	39 Y yttrium 39	40 Zr zirconium 40	41 Nb niobium 41	42 Mo molybdenum 42	43 Tc technetium 43	44 Ru ruthenium 44	45 Rh rhodium 45
	55 Cs caesium 55	56 Ba barium 56	57 La* lanthanum 57	72 Hf hafnium 72	73 Ta tantalum 73	74 W tungsten 74	75 Re rhenium 75	76 Os osmium 76	77 Ir iridium 77
	[223] Fr francium 87	[226] Ra radium 88	[227] Ac* actinium 89	[261] Rf rutherfordium 104	[262] Db dubnium 105	[266] Sg seaborgium 106	[264] Bh bohrium 107	[277] Hs hassium 108	[268] Mt meitnerium 109
	133 Cs caesium 55	137 Ba barium 56	139 La* lanthanum 57	178 Hf hafnium 72	181 Ta tantalum 73	184 W tungsten 74	186 Re rhenium 75	190 Os osmium 76	192 Ir iridium 77
	85 Rb rubidium 37	88 Sr strontium 38	89 Y yttrium 39	91 Zr zirconium 40	93 Nb niobium 41	96 Mo molybdenum 42	[98] Tc technetium 43	101 Ru ruthenium 44	103 Rh rhodium 45
	119 Sr strontium 38	120 Y yttrium 39	121 Zr zirconium 40	122 Nb niobium 41	123 Mo molybdenum 42	124 Tc technetium 43	125 Ru ruthenium 44	126 Rh rhodium 45	127 Pd palladium 46
	115 In indium 49	116 Sn tin 50	117 Pb lead 82	118 Hg mercury 80	119 Tl thallium 81	120 Pb lead 82	121 Bi bismuth 83	122 Po polonium 84	123 At astatine 85
	131 Xe xenon 54	132 At astatine 85	133 Rn radon 86	134 Fr francium 87	135 Ra radium 88	136 Ac actinium 89	137 La lanthanum 57	138 Ce cerium 58	139 Pr praseodymium 59
	131 Xe xenon 54	132 At astatine 85	133 Rn radon 86	134 Fr francium 87	135 Ra radium 88	136 Ac actinium 89	137 La lanthanum 57	138 Ce cerium 58	139 Pr praseodymium 59
	131 Xe xenon 54	132 At astatine 85	133 Rn radon 86	134 Fr francium 87	135 Ra radium 88	136 Ac actinium 89	137 La lanthanum 57	138 Ce cerium 58	139 Pr praseodymium 59
	131 Xe xenon 54	132 At astatine 85	133 Rn radon 86	134 Fr francium 87	135 Ra radium 88	136 Ac actinium 89	137 La lanthanum 57	138 Ce cerium 58	139 Pr praseodymium 59
	131 Xe xenon 54	132 At astatine 85	133 Rn radon 86	134 Fr francium 87	135 Ra radium 88	136 Ac actinium 89	137 La lanthanum 57	138 Ce cerium 58	139 Pr praseodymium 59
	131 Xe xenon 54	132 At astatine 85	133 Rn radon 86	134 Fr francium 87	135 Ra radium 88	136 Ac actinium 89	137 La lanthanum 57	138 Ce cerium 58	139 Pr praseodymium 59
	131 Xe xenon 54	132 At astatine 85	133 Rn radon 86	134 Fr francium 87	135 Ra radium 88	136 Ac actinium 89	137 La lanthanum 57	138 Ce cerium 58	139 Pr praseodymium 59
	131 Xe xenon 54	132 At astatine 85	133 Rn radon 86	134 Fr francium 87	135 Ra radium 88	136 Ac actinium 89	137 La lanthanum 57	138 Ce cerium 58	139 Pr praseodymium 59
	131 Xe xenon 54	132 At astatine 85	133 Rn radon 86	134 Fr francium 87	135 Ra radium 88	136 Ac actinium 89	137 La lanthanum 57	138 Ce cerium 58	139 Pr praseodymium 59
	131 Xe xenon 54	132 At astatine 85	133 Rn radon 86	134 Fr francium 87	135 Ra radium 88	136 Ac actinium 89	137 La lanthanum 57	138 Ce cerium 58	139 Pr praseodymium 59
	131 Xe xenon 54	132 At astatine 85	133 Rn radon 86	134 Fr francium 87	135 Ra radium 88	136 Ac actinium 89	137 La lanthanum 57	138 Ce cerium 58	139 Pr praseodymium 59
	131 Xe xenon 54	132 At astatine 85	133 Rn radon 86	134 Fr francium 87	135 Ra radium 88	136 Ac actinium 89	137 La lanthanum 57	138 Ce cerium 58	139 Pr praseodymium 59
	131 Xe xenon 54	132 At astatine 85	133 Rn radon 86	134 Fr francium 87	135 Ra radium 88	136 Ac actinium 89	137 La lanthanum 57	138 Ce cerium 58	139 Pr praseodymium 59
	131 Xe xenon 54	132 At astatine 85	133 Rn radon 86	134 Fr francium 87	135 Ra radium 88	136 Ac actinium 89	137 La lanthanum 57	138 Ce cerium 58	139 Pr praseodymium 59
	131 Xe xenon 54	132 At astatine 85	133 Rn radon 86	134 Fr francium 87	135 Ra radium 88	136 Ac actinium 89	137 La lanthanum 57	138 Ce cerium 58	139 Pr praseodymium 59
	131 Xe xenon 54	132 At astatine 85	133 Rn radon 86	134 Fr francium 87	135 Ra radium 88	136 Ac actinium 89	137 La lanthanum 57	138 Ce cerium 58	139 Pr praseodymium 59
	131 Xe xenon 54	132 At astatine 85	133 Rn radon 86	134 Fr francium 87	135 Ra radium 88	136 Ac actinium 89	137 La lanthanum 57	138 Ce cerium 58	139 Pr praseodymium 59
	131 Xe xenon 54	132 At astatine 85	133 Rn radon 86	134 Fr francium 87	135 Ra radium 88	136 Ac actinium 89	137 La lanthanum 57	138 Ce cerium 58	139 Pr praseodymium 59
	131 Xe xenon 54	132 At astatine 85	133 Rn radon 86	134 Fr francium 87	135 Ra radium 88	136 Ac actinium 89	137 La lanthanum 57	138 Ce cerium 58	139 Pr praseodymium 59
	131 Xe xenon 54	132 At astatine 85	133 Rn radon 86	134 Fr francium 87	135 Ra radium 88	136 Ac actinium 89	137 La lanthanum 57	138 Ce cerium 58	139 Pr praseodymium 59
	131 Xe xenon 54	132 At astatine 85	133 Rn radon 86	134 Fr francium 87	135 Ra radium 88	136 Ac actinium 89	137 La lanthanum 57	138 Ce cerium 58	139 Pr praseodymium 59
	131 Xe xenon 54	132 At astatine 85	133 Rn radon 86	134 Fr francium 87	135 Ra radium 88	136 Ac actinium 89	137 La lanthanum 57	138 Ce cerium 58	139 Pr praseodymium 59
	131 Xe xenon 54	132 At astatine 85	133 Rn radon 86	134 Fr francium 87	135 Ra radium 88	136 Ac actinium 89	137 La lanthanum 57	138 Ce cerium 58	139 Pr praseodymium 59
	131 Xe xenon 54	132 At astatine 85	133 Rn radon 86	134 Fr francium 87	135 Ra radium 88	136 Ac actinium 89	137 La lanthanum 57	138 Ce cerium 58	139 Pr praseodymium 59
	131 Xe xenon 54	132 At astatine 85	133 Rn radon 86	134 Fr francium 87	135 Ra radium 88	136 Ac actinium 89	137 La lanthanum 57	138 Ce cerium 58	139 Pr praseodymium 59
	131 Xe xenon 54	132 At astatine 85	133 Rn radon 86	134 Fr francium 87	135 Ra radium 88	136 Ac actinium 89	137 La lanthanum 57	138 Ce cerium 58	139 Pr praseodymium 59
	131 Xe xenon 54	132 At astatine 85	133 Rn radon 86	134 Fr francium 87	135 Ra radium 88	136 Ac actinium 89	137 La lanthanum 57	138 Ce cerium 58	139 Pr praseodymium 59
	131 Xe xenon 54	132 At astatine 85	133 Rn radon 86	134 Fr francium 87	135 Ra radium 88	136 Ac actinium 89	137 La lanthanum 57	138 Ce cerium 58	139 Pr praseodymium 59
	131 Xe xenon 54	132 At astatine 85	133 Rn radon 86	134 Fr francium 87	135 Ra radium 88	136 Ac actinium 89	137 La lanthanum 57	138 Ce cerium 58	139 Pr praseodymium 59
	131 Xe xenon 54	132 At astatine 85	133 Rn radon 86	134 Fr francium 87	135 Ra radium 88	136 Ac actinium 89	137 La lanthanum 57	138 Ce cerium 58	139 Pr praseodymium 59
	131 Xe xenon 54	132 At astatine 85	133 Rn radon 86	134 Fr francium 87	135 Ra radium 88	136 Ac actinium 89	137 La lanthanum 57	138 Ce cerium 58	139 Pr praseodymium 59
	131 Xe xenon 54	132 At astatine 85	133 Rn radon 86	134 Fr francium 87	135 Ra radium 88	136 Ac actinium 89	137 La lanthanum 57	138 Ce cerium 58	139 Pr praseodymium 59
	131 Xe xenon 54	132 At astatine 85	133 Rn radon 86	134 Fr francium 87	135 Ra radium 88	136 Ac actinium 89	137 La lanthanum 57	138 Ce cerium 58	139 Pr praseodymium 59
	131 Xe xenon 54	132 At astatine 85	133 Rn radon 86	134 Fr francium 87	135 Ra radium 88	136 Ac actinium 89	137 La lanthanum 57	138 Ce cerium 58	139 Pr praseodymium 59
	131 Xe xenon 54	132 At astatine 85	133 Rn radon 86	134 Fr francium 87	135 Ra radium 88	136 Ac actinium 89	137 La lanthanum 57	138 Ce cerium 58	139 Pr praseodymium 59
	131 Xe xenon 54	132 At astatine 85	133 Rn radon 86	134 Fr francium 87	135 Ra radium 88	136 Ac actinium 89	137 La lanthanum 57	138 Ce cerium 58	139 Pr praseodymium 59
	131 Xe xenon 54	132 At astatine 85	133 Rn radon 86	134 Fr francium 87	135 Ra radium 88	136 Ac actinium 89	137 La lanthanum 57	138 Ce cerium 58	139 Pr praseodymium 59
	131 Xe xenon 54	132 At astatine 85	133 Rn radon 86	134 Fr francium 87	135 Ra radium 88	136 Ac actinium 89	137 La lanthanum 57	138 Ce cerium 58	139 Pr praseodymium 59
	131 Xe xenon 54	132 At astatine 85	133 Rn radon 86	134 Fr francium 87	135 Ra radium 88	136 Ac actinium 89	137 La lanthanum 57	138 Ce cerium 58	139 Pr praseodymium 59
	131 Xe xenon 54	132 At astatine 85	133 Rn radon 86	134 Fr francium 87	135 Ra radium 88	136 Ac actinium 89	137 La lanthanum 57	138 Ce cerium 58	139 Pr praseodymium 59
	131 Xe xenon 54	132 At astatine 85	133 Rn radon 86	134 Fr francium 87	135 Ra radium 88	136 Ac actinium 89	137 La lanthanum 57	138 Ce cerium 58	139 Pr praseodymium 59
	131 Xe xenon 54	132 At astatine 85	133 Rn radon 86	134 Fr francium 87	135 Ra radium 88	136 Ac actinium 89	137		