

Centre Number						Candidate Number				
Surname										
Other Names										
Candidate Signature										

For Examiner's Use	
Examiner's Initials	
Question	Mark
1	
2	
3	
4	
5	
6	
7	
TOTAL	



General Certificate of Secondary Education  
Higher Tier  
June 2011

## Additional Science

Unit Physics P2

PHY2H

## Physics

Unit Physics P2

H

### Written Paper

Friday 27 May 2011 9.00 am to 9.45 am

**For this paper you must have:**

- a ruler.
- You may use a calculator.

**Time allowed**

- 45 minutes

**Instructions**

- Use black ink or black ball-point pen.
- Fill in the boxes at the top of this page.
- Answer **all** questions.
- You must answer the questions in the spaces provided. Do not write outside the box around each page or on blank pages.
- Do all rough work in this book. Cross through any work you do not want to be marked.

**Information**

- The marks for questions are shown in brackets.
- The maximum mark for this paper is 45.
- You are expected to use a calculator where appropriate.
- You are reminded of the need for good English and clear presentation in your answers.

**Advice**

- In all calculations, show clearly how you work out your answer.



J U N 1 1 P H Y 2 H 0 1

Answer **all** questions in the spaces provided.

- 1** **Diagram 1** shows a hairdryer.  
**Diagram 2** shows how the heaters and fan of the hairdryer are connected to a 3-pin plug.  
 The hairdryer does not have an earth wire.

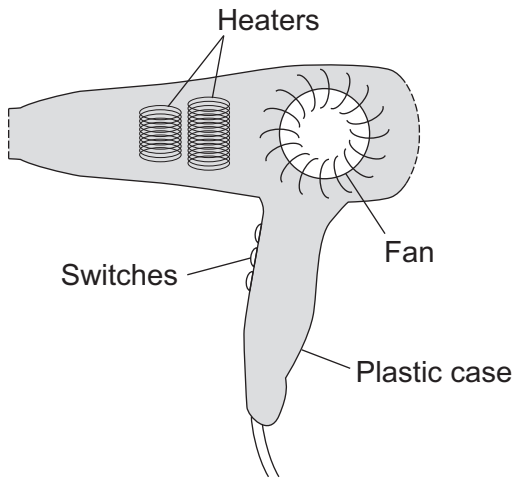

**Diagram 1**

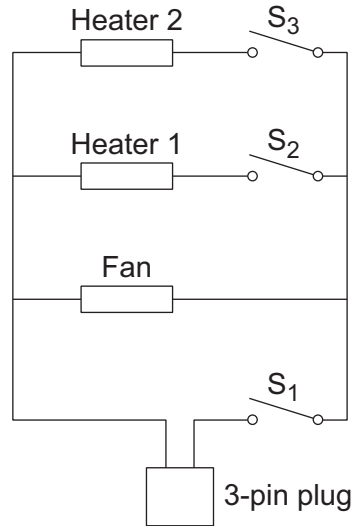

**Diagram 2**

- 1 (a)** What colour is the insulation around the wire connected to the live pin inside the plug?

.....  
 (1 mark)

- 1 (b)** Why does the hairdryer **not** need an earth wire?

.....  
 .....  
 (1 mark)

- 1 (c)** All the switches are shown in the OFF position.

- 1 (c) (i)** Which switch or switches have to be ON to make:

(1) only the fan work; .....

(2) heater 2 work? .....  
 (2 marks)



**1 (c) (ii)** The heaters can only be switched on when the fan is also switched on.

Explain why.

.....

.....

.....

.....

.....

(2 marks)

**1 (d)** The table shows the current drawn from the 230 volt mains electricity supply when different parts of the hairdryer are switched on.

	Current in amps
Fan only	1.0
Fan and heater 1	4.4
Fan and both heaters	6.5

Use the equation in the box to calculate the maximum power of the hairdryer.

$$\text{power} = \text{current} \times \text{potential difference}$$

Show clearly how you work out your answer and give the unit.

.....

.....

Maximum power = .....

(3 marks)

9

**Turn over for the next question**

**Turn over ►**



2 (a) The diagram shows a builder using a plank to help load rubble into a skip.

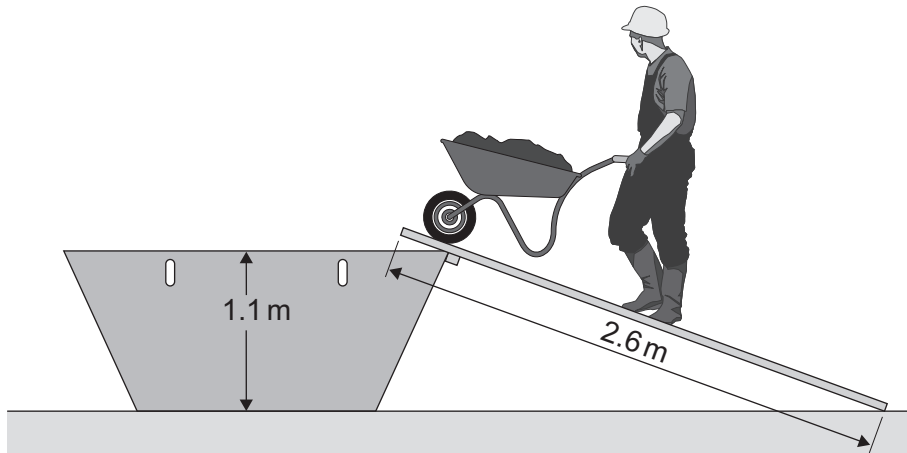

The builder uses a force of 220 N to push the wheelbarrow up the plank.

Use information from the diagram and the equation in the box to calculate the work done to push the wheelbarrow up the plank to the skip.

$$\text{work done} = \text{force applied} \times \text{distance moved in the direction of force}$$

Show clearly how you work out your answer.

.....

.....

Work done = ..... J  
(2 marks)

2 (b) A student investigated how the force needed to pull a brick up a slope, at a steady speed, depends on the angle of the slope. The apparatus used by the student is shown in the diagram.

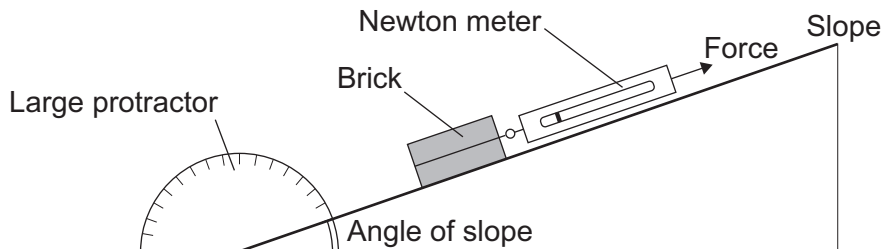

The student used the results from the investigation to plot the points for a graph of force used against the angle of the slope.



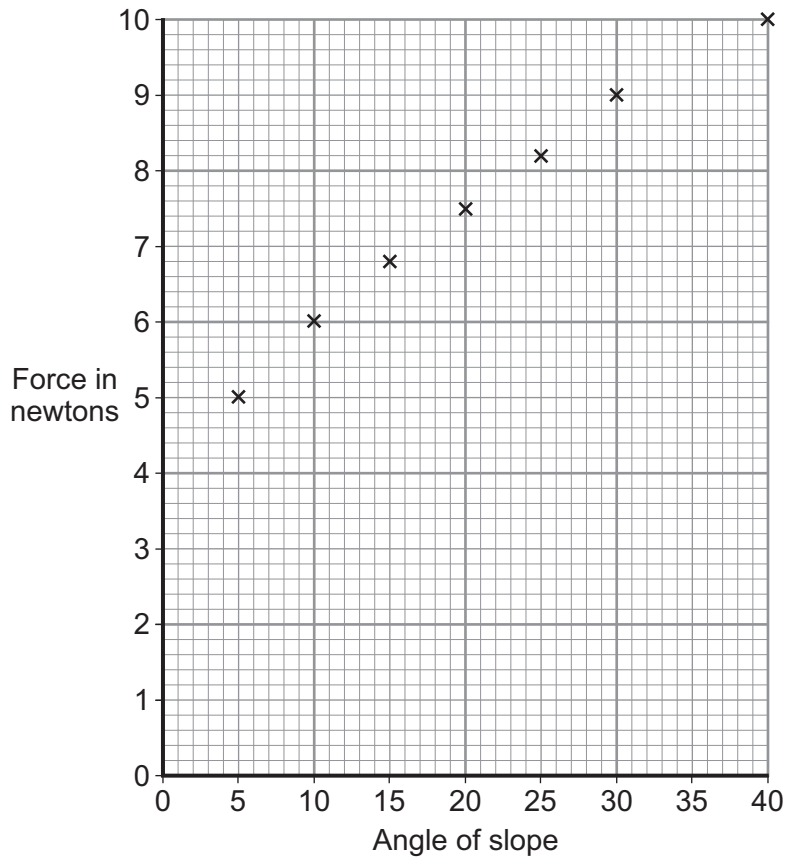

2 (b) (i) Draw a line of best fit for these points. (1 mark)

2 (b) (ii) How does the force used to pull the brick up the slope change as the angle of the slope increases?

.....

.....

(1 mark)

2 (b) (iii) Consider the results from this experiment.  
Should the student recommend that the builder use a long plank or a short plank to help load the skip?

Draw a ring around your answer.

**long plank**

**short plank**

Explain the reason for your answer.

.....

.....

.....

.....

(2 marks)

**Turn over ▶**



- 3 The diagram represents an atom of beryllium.

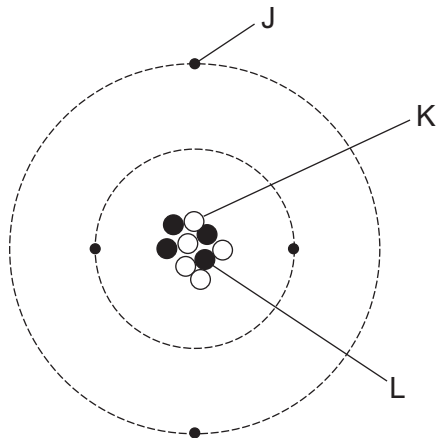

- 3 (a) Complete the following statements by writing one of the letters, **J**, **K** or **L**, in each box.

Each letter should be used only **once**.

The particle with a positive charge is

The particle with the smallest mass is

The particle with no charge is

(2 marks)

- 3 (b) Give the reason why all atoms have a total charge of zero.

.....  
.....

(1 mark)

- 3 (c) Complete the following sentence.

There are several isotopes of beryllium. Atoms of different beryllium

isotopes will have different numbers of .....

(1 mark)

- 3 (d) What happens to the structure of an atom to change it into an ion?

.....  
.....

(1 mark)

5



- 4 When the nucleus of a radium-225 atom decays, it changes into a nucleus of actinium-225.



What type of radiation is emitted by radium-225?

Draw a ring around your answer.

**alpha**

**beta**

**gamma**

Explain the reason for your answer.

.....

.....

.....

.....

.....

.....

(3 marks)

3

**Turn over for the next question**

**Turn over ►**



- 5 The diagram shows the velocity-time graph for an object over a 10 second period.

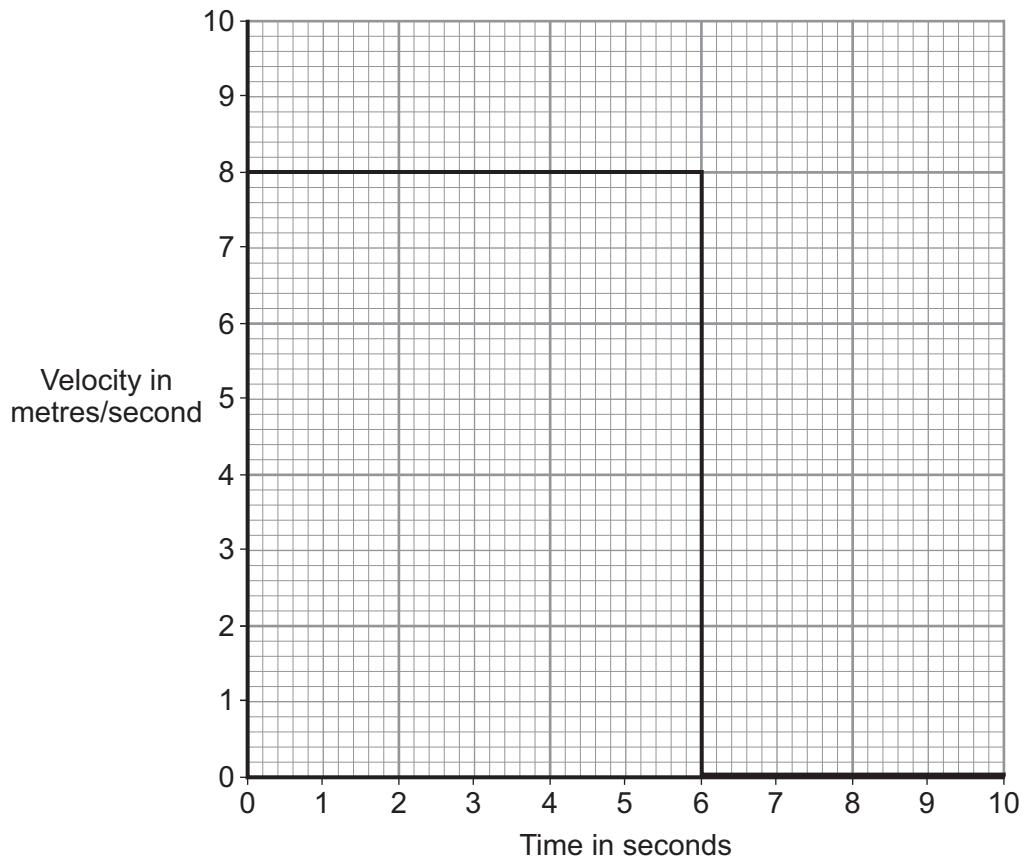

- 5 (a) Use the graph to calculate the distance travelled by the object in 10 seconds.  
Show clearly how you work out your answer.

.....  
.....

Distance = ..... m  
(2 marks)





**5 (b)** Complete the distance-time graph for the object over the same 10 seconds.

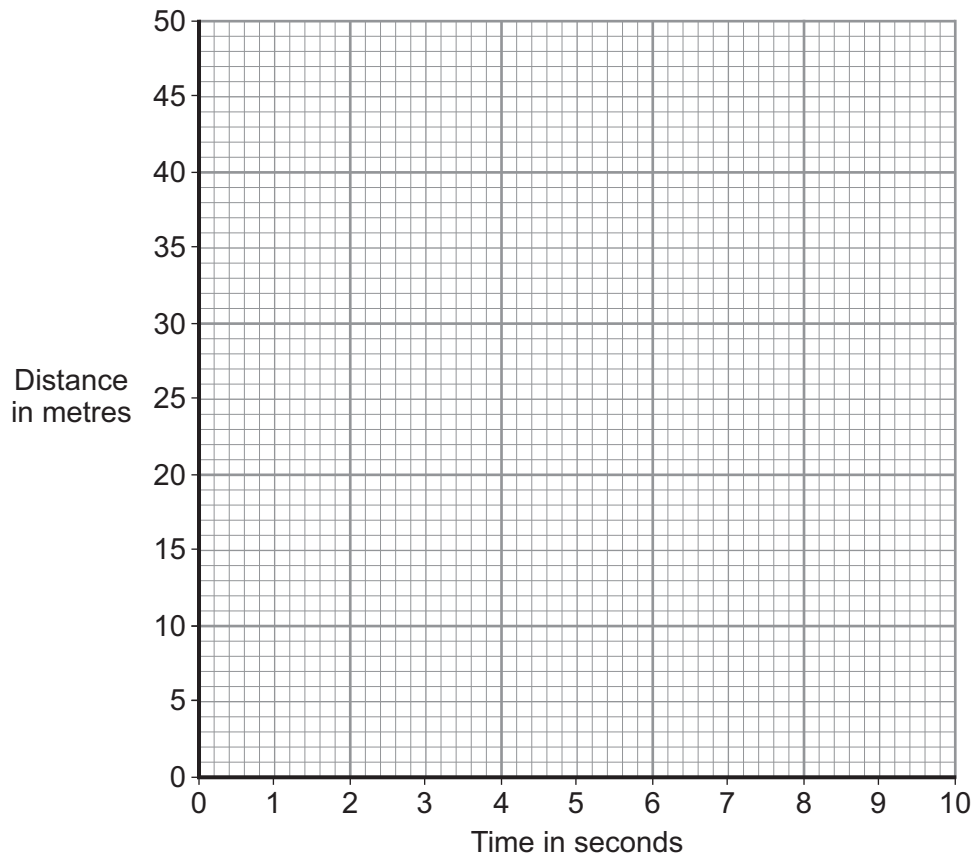

(2 marks)

4

Turn over for the next question

Turn over ►



6 The diagram shows a strain gauge, which is an electrical device used to monitor a changing force.

Applying a force to the gauge causes it to stretch.  
This makes the electrical resistance of the wire change.

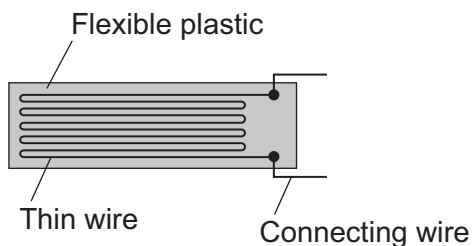

6 (a) (i) Using the correct symbols, **add** to the diagram to show how a battery, an ammeter and a voltmeter can be used to find the resistance of the strain gauge drawn above. (2 marks)

6 (a) (ii) When in use, the strain gauge is always connected to a d.c. power supply, such as a battery.

How is a d.c. (direct current) power supply different from an a.c. (alternating current) power supply?

.....

.....

.....

(1 mark)



**6 (b)** Before any force is applied, the unstretched gauge, correctly connected to a 3.0V battery, has a current of 0.040A flowing through it.

**6 (b) (i)** Use the equation in the box to calculate the resistance of the unstretched gauge.

potential difference = current × resistance

Show clearly how you work out your answer.

.....  
.....

Resistance = ..... Ω  
(2 marks)

**6 (b) (ii)** Stretching the gauge causes the current flowing through the gauge to decrease.

What happens to the resistance of the gauge when it is stretched?

.....  
.....

(1 mark)

**6 (b) (iii)** What form of energy is stored in the gauge when a force is applied and the gauge stretches?

.....

(1 mark)

7

**Turn over for the next question**

**Turn over ►**



7 The arrows in the diagram represent the horizontal forces acting on a motorbike at one moment in time.

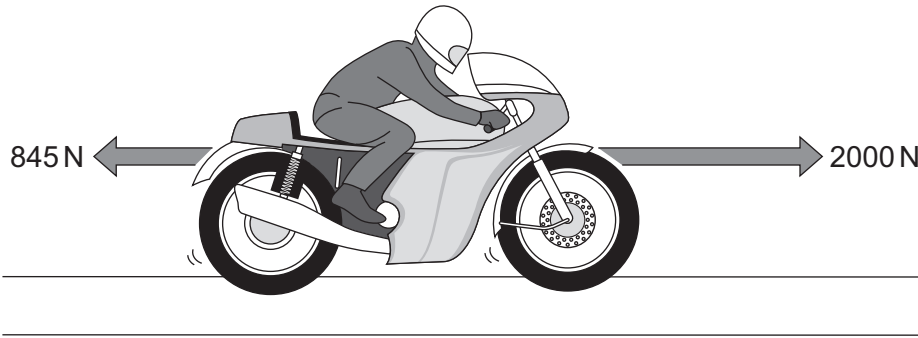

7 (a) The mass of the motorbike and rider is 275 kg.

Use the equation in the box to calculate the acceleration of the motorbike at this moment in time.

$$\text{resultant force} = \text{mass} \times \text{acceleration}$$

Show clearly how you work out your answer.

.....

.....

.....

.....

.....

Acceleration = ..... m/s<sup>2</sup>  
(3 marks)



**7 (b)** A road safety organisation has investigated the causes of motorbike accidents.

The main aim of the investigation was to find out whether there was any evidence that young, inexperienced riders were more likely to be involved in an accident than older, experienced riders.

Data obtained by the organisation from a sample of 1800 police files involving motorbike accidents, is summarised in the table.

Size of motorbike engine	Percentage of all motorbikes sold	Total number in the sample of 1800 accident files
up to 125cc	36	774
126 to 350cc	7	126
351 to 500cc	7	162
over 500cc	50	738

Most of the motorbikes with engines up to 125 cc were ridden by young people. The motorbikes with engines over 500 cc were ridden by older, more experienced riders.

**7 (b) (i)** In terms of the main aim of the investigation, is this data valid?

Draw a ring around your answer.      **NO**      **YES**

Explain the reason for your answer.

.....

.....

.....

.....

(2 marks)

**Question 7 continues on the next page**

**Turn over ►**



7 (b) (ii) The organisation concluded that:

“Young, inexperienced riders are more likely to be involved in a motorbike accident than older, experienced riders”.

Explain how the data supports this conclusion.

.....  
.....  
.....  
.....

(2 marks)

7 (c) Of particular concern to motorbike riders is the design of steel crash barriers. Riders falling off and sliding at high speed into a steel support post are often seriously injured.

One way to reduce the risk of serious injury is to cover the post in a thick layer of high impact polyurethane foam.

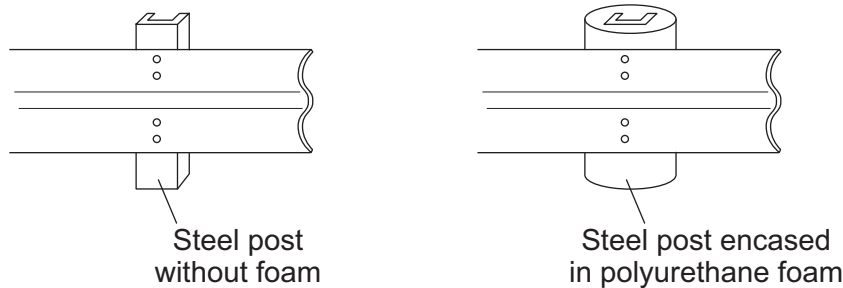

7 (c) (i) Use the ideas of momentum to explain how the layer of foam reduces the risk of serious injury to a motorbike rider sliding at high speed into the support post.

.....  
.....  
.....  
.....  
.....

(3 marks)



- 7 (c) (ii)** Crash barrier tests use dummies that collide at 17 m/s with the barrier. Each test costs about £12 000. New safety devices for crash barriers are tested many times to make sure that they will improve safety.

Do you think that the cost of developing the new safety devices is justified?

Draw a ring around your answer.      **NO**      **YES**

Give a reason for your answer.

.....  
.....

(1 mark)

11
----

**END OF QUESTIONS**



**There are no questions printed on this page**

**DO NOT WRITE ON THIS PAGE  
ANSWER IN THE SPACES PROVIDED**

