

General Certificate of Secondary Education
2014

Additional Mathematics

Paper 2
Mechanics and Statistics

[G0302]

MV18

FRIDAY 13 JUNE, MORNING

TIME

2 hours, plus your additional time allowance.

INSTRUCTIONS TO CANDIDATES

Write your Centre Number and Candidate Number on the Answer Booklet and the Supplementary Answer Booklet provided. Answer **all twelve** questions.

At the conclusion of the examination attach the Supplementary Answer Booklet to your Answer Booklet using the treasury tag supplied.

INFORMATION FOR CANDIDATES

The total mark for this paper is 100.

Figures in brackets printed at the end of each question indicate the marks awarded to each question or part question.

You may use your calculator.

A copy of the formulae list is provided.

Take $g = 10 \text{ m/s}^2$ when required.

Answer **all twelve** questions.

- 1 (Throughout this question **i** and **j** denote unit vectors parallel to a set of standard x - y axes.)

Vectors **a** and **b** are defined by

$$\mathbf{a} = 2\mathbf{i} + 3\mathbf{j} \quad \text{and} \quad \mathbf{b} = 4\mathbf{i} - 2\mathbf{j}$$

Find

- (i) the vector $3\mathbf{a} - \mathbf{b}$ in terms of **i** and **j**, [2 marks]
- (ii) the magnitude of the vector $3\mathbf{a} - \mathbf{b}$, [1 mark]
- (iii) the acute angle the vector $3\mathbf{a} - \mathbf{b}$ makes with the positive x -axis. [1 mark]

- 2 On Monday a librarian recorded the ages of people visiting the library. The results are summarised in **Table 1**.

Table 1

Age (years)	4–11	12–17	18–37	38–57	58–77
Number of visitors	44	36	63	56	48

Using **Fig. 1** in your Supplementary Answer Booklet, draw a histogram to represent this information. **Label each axis clearly.** [5 marks]

3 A bag contains 4 red sweets and some yellow sweets.

One sweet is selected at random.

By letting x equal the number of yellow sweets in the bag,

(i) write down the probability, in terms of x , that the sweet selected is red. [1 mark]

A second sweet is selected at random from the remaining sweets in the bag.

(ii) Write down the probability, in terms of x , that **both** sweets selected are red. [2 marks]

The probability that both sweets selected are red is $\frac{1}{6}$

(iii) By forming an equation in x , determine the number of yellow sweets that were in the bag. [2 marks]

- 4 A block X, of mass m kg, is held in equilibrium by two light inextensible strings XA and XB, attached to a horizontal ceiling. The strings are inclined to the ceiling at angles of 30° and 51° , as shown in **Fig. 2**.

The tension in the string XA is 20 N.

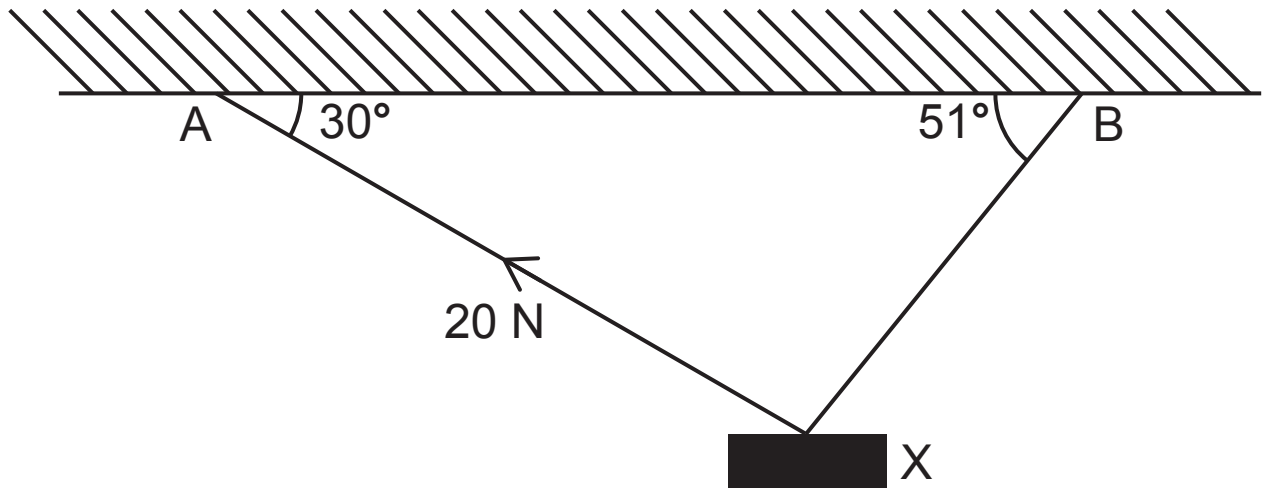

Fig. 2

- (i) Copy **Fig. 2** and mark on it all the forces acting on the block. [1 mark]
- (ii) Calculate the tension in the string XB. [2 marks]
- (iii) Calculate the value of m . [3 marks]

- 5 A uniform plank AB, of length 6 m and mass 12 kg, is held horizontally by two vertical strings attached to a ceiling. The strings are connected to the plank at the points C and D, as shown in **Fig. 3**, where $AC = 1$ m and $AD = 4$ m.

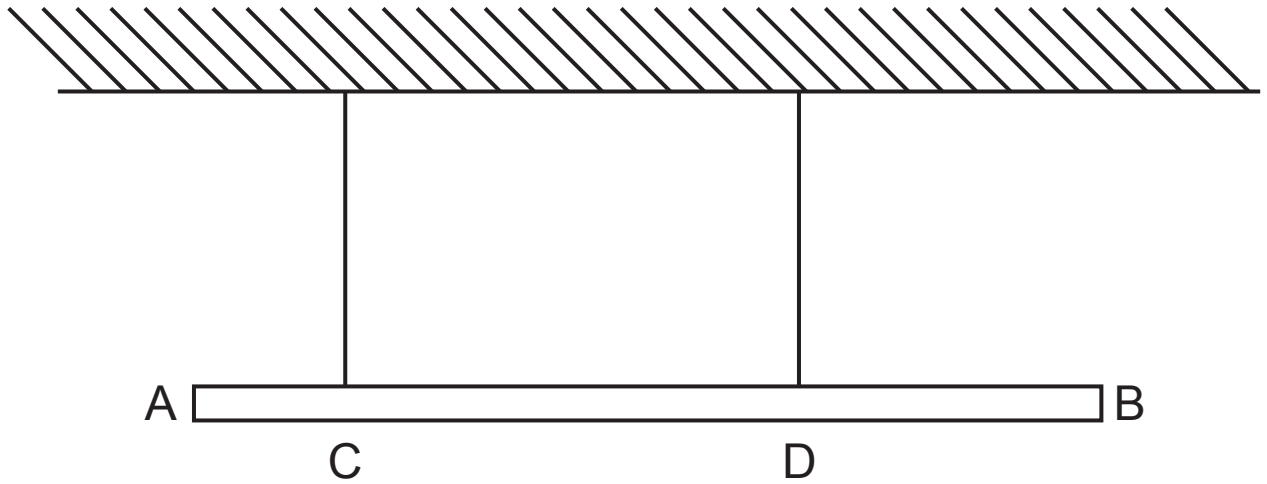

Fig. 3

- (i) Copy **Fig. 3** and mark on it all the forces acting on the plank. [1 mark]
- (ii) Calculate the tension in each of the two strings. [3 marks]

A mass M kg is attached to the end B so that the plank is on the point of turning about D.

- (iii) Write down the tension in the string at C. [1 mark]

- (iv) Calculate the value of M . [3 marks]

- 6 (a) While waiting for his flight home, Dominic recorded the time intervals, in minutes and seconds, between planes taking off from one runway at Heathrow Airport. His results are given in **Table 2**.

Table 2

Minutes	Seconds
0	58
2	17
0	50
1	04
1	21
0	58
0	52
1	56
1	11
2	13

- (i) Calculate the mean of these times. Give your answer in minutes and seconds. [2 marks]
- (ii) Calculate the standard deviation of these times. [2 marks]

(b) When training for a ski jump competition Gerry recorded the length of each of his jumps, correct to the nearest metre. His results are summarised in **Table 3**.

Table 3

Distance (m)	31–50	51–70	71–90	91–100	101–110	111–120
Number of jumps	2	11	16	23	8	1

(i) Calculate an estimate for the median distance jumped. [4 marks]

(ii) Why is this an **estimate** for the median distance jumped? [1 mark]

- 7 A man is jogging at a constant speed of 4 m/s when he passes a stationary cyclist.
Ten seconds after he passes the cyclist, she gives chase.

The cyclist accelerates uniformly for 6 seconds until she reaches a speed of 9 m/s.

She maintains this speed until she reaches the jogger.

- (i) On the axes drawn in **Fig. 4** in your Supplementary Answer Booklet, sketch the speed–time graph for the cyclist. [2 marks]

Hence, or otherwise, calculate

- (ii) the time taken for the cyclist to reach the jogger,
[5 marks]

- (iii) the distance travelled by the cyclist when she reaches the jogger. [2 marks]

8 Molly is playing a game with a regular six-sided die.

She throws the die once, and if the score is not a 6 then this score is recorded.

If she throws a 6 on her first throw, then she is given a second throw and the total of both throws is recorded.

Find the probability of Molly getting

(i) a total score of 6, [1 mark]

(ii) a total score of 8, [2 marks]

(iii) a score greater than 8, [3 marks]

(iv) a score of 12, given that she scored greater than 8
[3 marks]

- 9 The number of motorists caught speeding by a fixed safety camera was recorded each quarter over a three year period. The results are given in **Table 4**.

Table 4

	Jan–Mar	Apr–Jun	Jul–Sep	Oct–Dec
2011	1057	857	986	1132
2012	989	805	926	1076
2013	921	749	862	1024

These data have been plotted on the graph given in **Fig. 5** in your Supplementary Answer Booklet.

- (i) Calculate appropriate moving averages to smooth the data. [2 marks]
- (ii) Plot these averages in **Fig. 5** and draw the trend line. [3 marks]
- (iii) Showing clearly where any reading is taken, use your trend line to calculate an estimate of the number of motorists expected to be caught speeding by this camera in the period January to March 2014. [4 marks]

10 A missile is fired vertically upwards from the ground. It starts from rest and rises with a constant acceleration of 5 m/s^2 . The missile's fuel burns out after 10 seconds.

Calculate

(i) the height of the missile after 10 seconds, [2 marks]

(ii) the speed of the missile after 10 seconds. [2 marks]

After the fuel runs out, the missile continues to rise vertically, and can be modelled as a particle travelling freely under gravity.

Calculate

(iii) the maximum height above the **ground** reached by the missile, [3 marks]

(iv) the time taken from the moment the missile leaves the ground until it reaches the ground again. [4 marks]

- 11** A block of mass 5 kg is on a rough plane which is inclined at an angle of 15° to the horizontal, as shown in **Fig. 6**.

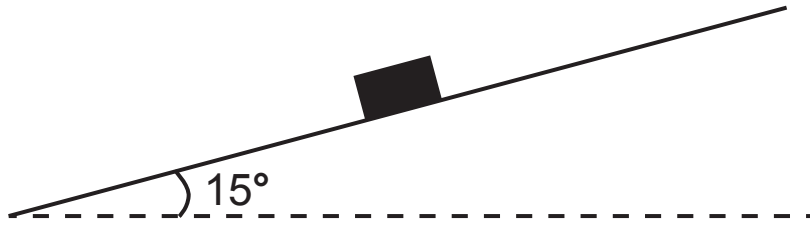

Fig. 6

The block is projected up the plane with a speed of 8 m/s, and travels up the plane for 2 seconds before coming to rest momentarily.

- (i) Show that the deceleration of the block is 4 m/s^2 .
[1 mark]

Calculate, giving your answers correct to 2 decimal places,

- (ii) the magnitude of the normal reaction between the block and the plane, [1 mark]

- (iii) the magnitude of the frictional resistance, [3 marks]

- (iv) the coefficient of friction. [2 marks]

The block now slides down the plane.

- (v) Calculate the acceleration of the block down the plane.
[5 marks]

12 The marks achieved by 10 students for each of their two Learning for Life and Work coursework pieces are recorded in **Table 5** below.

Table 5

First piece	36	26	34	32	22	47	33	46	38	35
Second piece	28	24	28	25	16	33	22	36	22	20

- (i) Find the rank orders for the marks in each of these coursework pieces. [2 marks]
- (ii) Calculate Spearman's coefficient of rank correlation. [4 marks]
- (iii) What significance, if any, do you attach to the value you obtained in (ii)? [1 mark]
- (iv) Calculate the mean score in each coursework piece. [1 mark]

The data from **Table 5** are plotted on the graph given in **Fig. 7** in your Supplementary Answer Booklet.

(v) Draw your line of best fit on the graph in the Supplementary Answer Booklet. [2 marks]

(vi) Determine the equation of the line of best fit which you have drawn. [3 marks]

THIS IS THE END OF THE QUESTION PAPER



Centre Number

71	
----	--

Candidate Number

--

**General Certificate of Secondary Education
2014**

Additional Mathematics

Paper 2
Mechanics and Statistics

[G0302]

MV18

FRIDAY 13 JUNE, MORNING

**SUPPLEMENTARY
ANSWER BOOKLET**

- 2 Using the information from **Table 1**, draw a histogram in **Fig. 1**. **Label each axis clearly.**

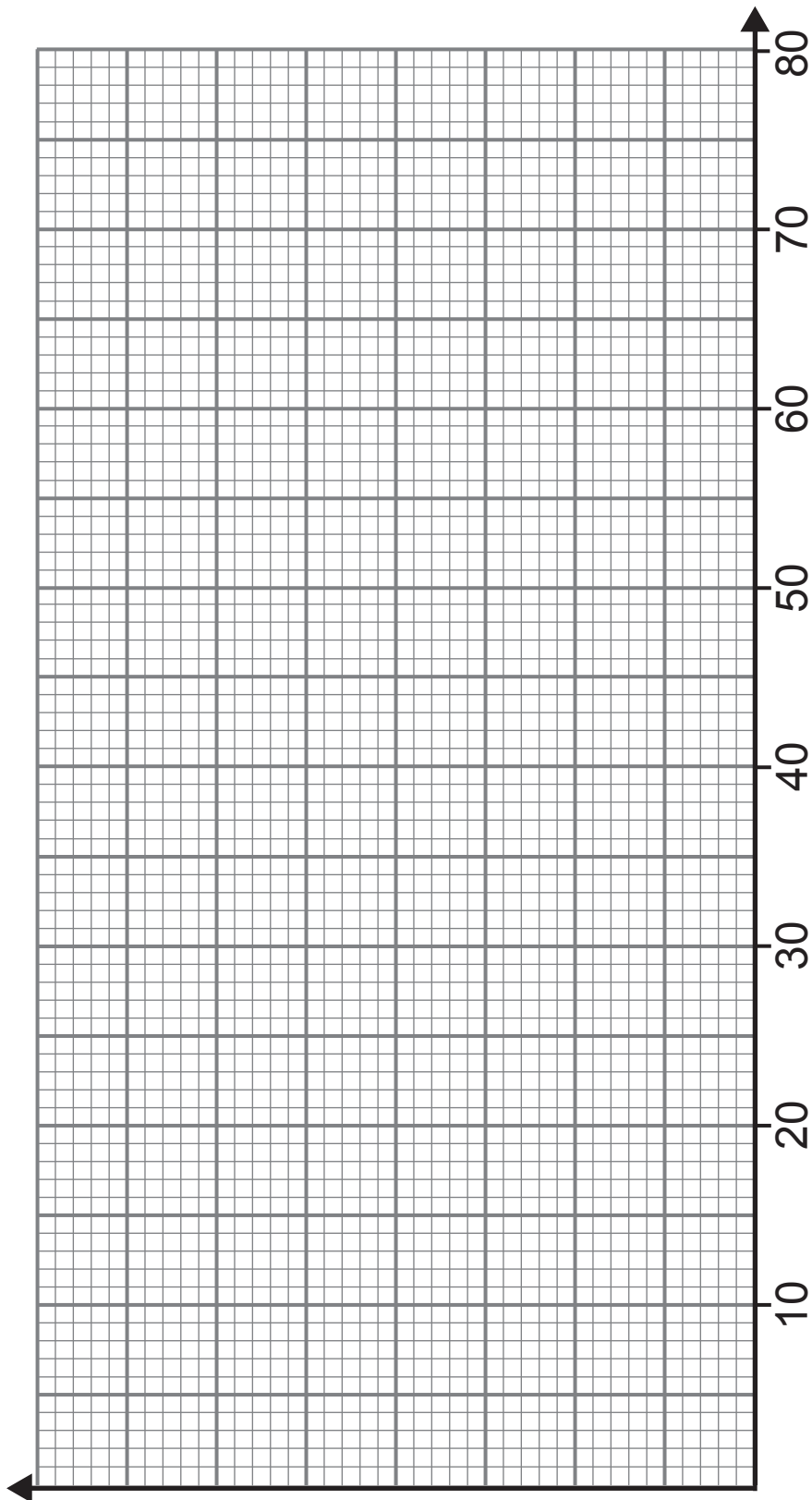

Fig. 1

7 Sketch the speed–time graph for the cyclist in **Fig. 4** below.

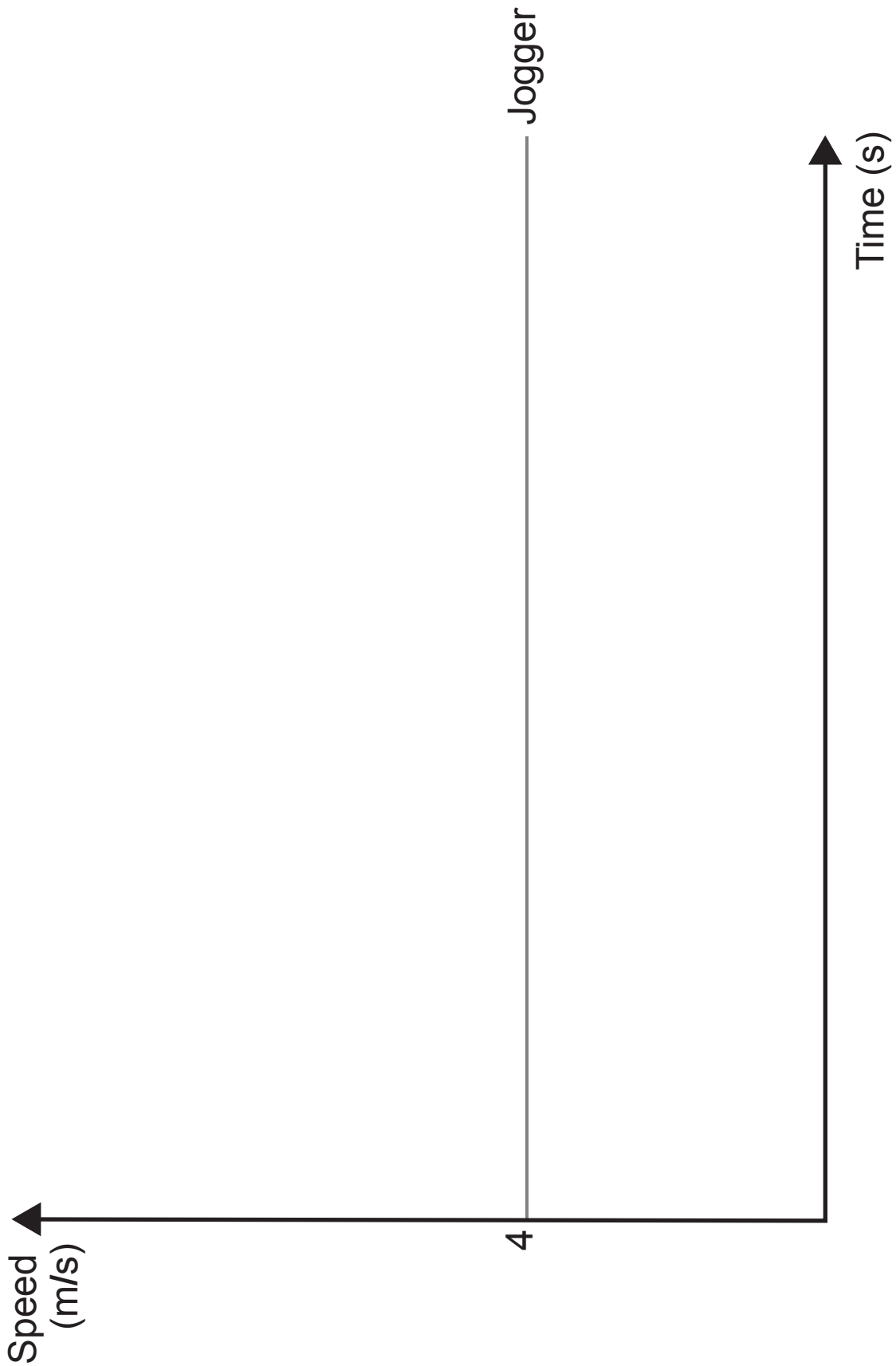

Fig. 4

9 Plot the moving averages in Fig. 5 and draw the trend line.

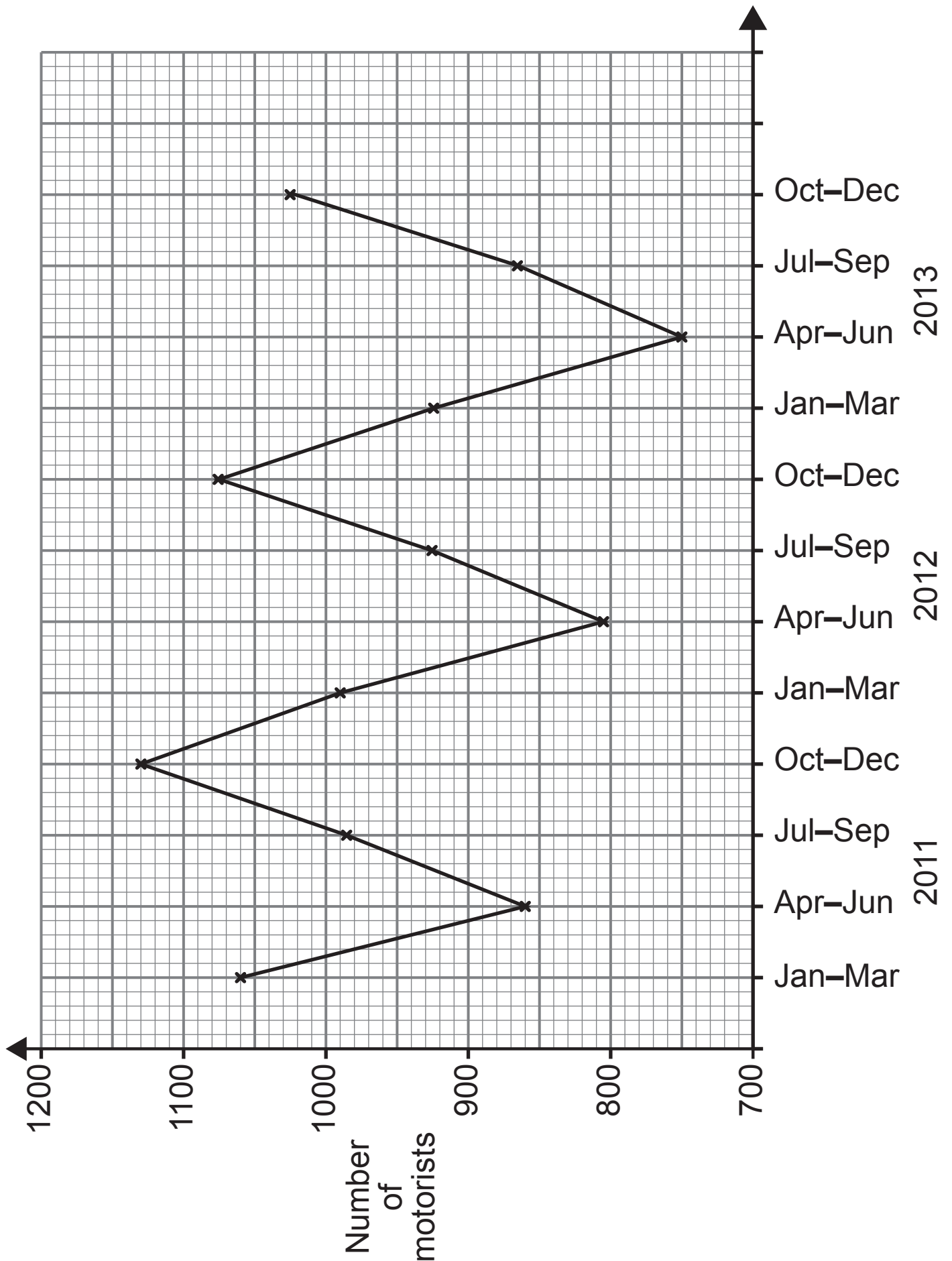

Fig. 5

12 (v) Draw your line of best fit through the data points shown in Fig. 7.

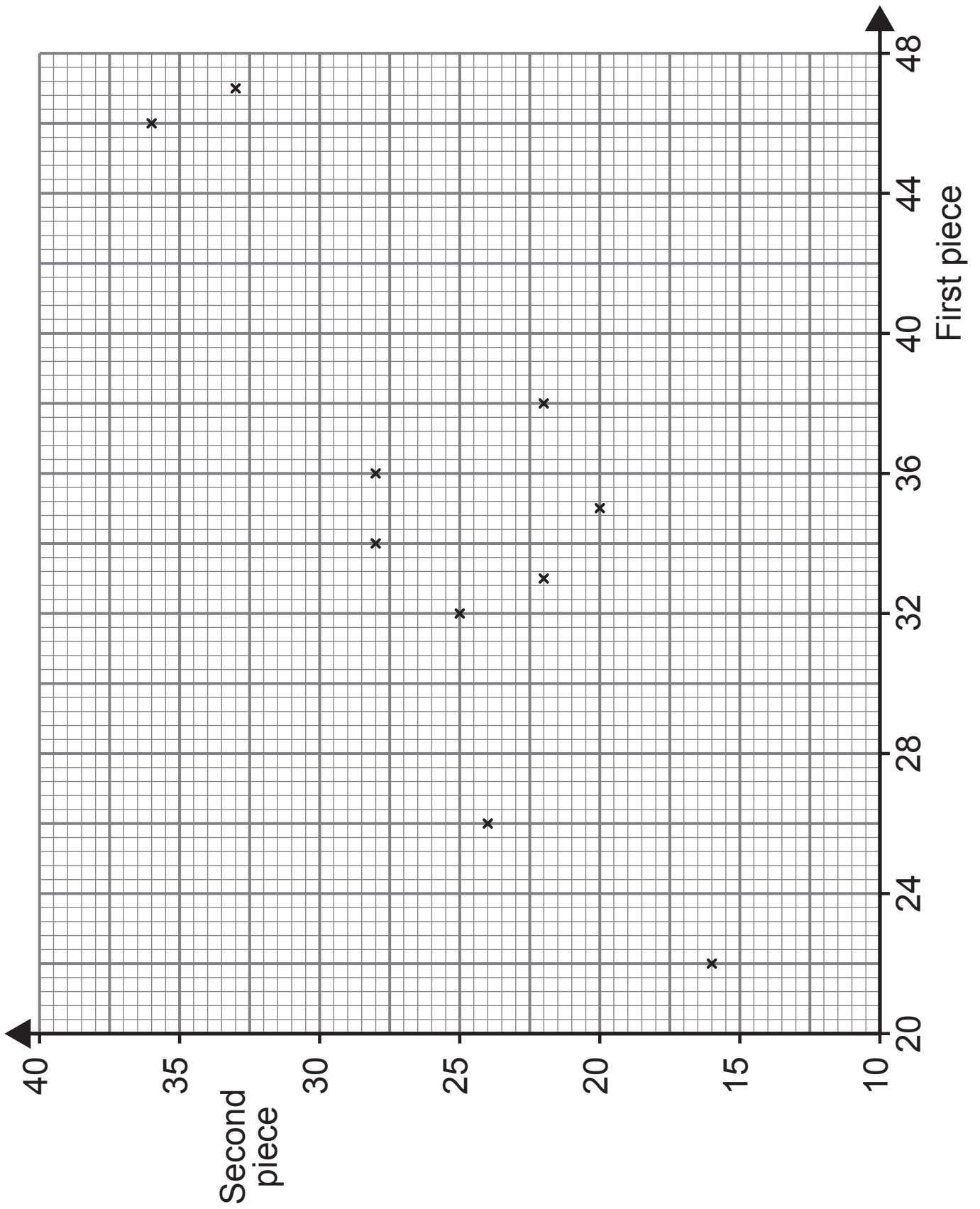

Fig. 7

