



Rewarding Learning

**General Certificate of Secondary Education
2013**

Additional Mathematics

Paper 2
Mechanics and Statistics

[G0302]

FRIDAY 24 MAY, AFTERNOON

**MARK
SCHEME**

General Marking Instructions

Introduction

Mark schemes are published to assist teachers and students in their preparation for examinations. Through the mark schemes teachers and students will be able to see what examiners are looking for in response to questions and exactly where the marks have been awarded. The publishing of the mark schemes may help to show that examiners are not concerned about finding out what a student does not know but rather with rewarding students for what they do know.

The Purpose of Mark Schemes

Examination papers are set and revised by teams of examiners and revisers appointed by the Council. The teams of examiners and revisers include experienced teachers who are familiar with the level and standards expected of students in schools and colleges.

The job of the examiners is to set the questions and the mark schemes; and the job of the revisers is to review the questions and mark schemes commenting on a large range of issues about which they must be satisfied before the question papers and mark schemes are finalised.

The questions and the mark schemes are developed in association with each other so that the issues of differentiation and positive achievement can be addressed right from the start. Mark schemes, therefore, are regarded as part of an integral process which begins with the setting of questions and ends with the marking of the examination.

The main purpose of the mark scheme is to provide a uniform basis for the marking process so that all the markers are following exactly the same instructions and making the same judgements in so far as this is possible. Before marking begins a standardising meeting is held where all the markers are briefed using the mark scheme and samples of the students' work in the form of scripts. Consideration is also given at this stage to any comments on the operational papers received from teachers and their organisations. During this meeting, and up to and including the end of the marking, there is provision for amendments to be made to the mark scheme. What is published represents this final form of the mark scheme.

It is important to recognise that in some cases there may well be other correct responses which are equally acceptable to those published: the mark scheme can only cover those responses which emerged in the examination. There may also be instances where certain judgements may have to be left to the experience of the examiner, for example, where there is no absolute correct response – all teachers will be familiar with making such judgements.

		MW1	MW1	AVAILABLE MARKS
1	(i)	mean = $77 \times 0.69 = 53.13$ s.d. = $8.1 \times 0.69 = 5.589$	MW1	
	(ii)	mean = $(77 + 0.2) \times 0.98 = 75.656$ s.d. = $8.1 \times 0.98 = 7.938$	MW1 M1, W1	5
2	(i)	$\mathbf{u} = 4\mathbf{i} - 2\mathbf{j}$ $\mathbf{v} = 3\mathbf{i} + 9\mathbf{j}$ $t = 6$ $\mathbf{s} = \frac{1}{2}t(\mathbf{u} + \mathbf{v})$ $\mathbf{s} = 3(7\mathbf{i} + 7\mathbf{j})$ $\mathbf{s} = (21\mathbf{i} + 21\mathbf{j})\text{m}$	M1, W1	
	(ii)	$\mathbf{u} = 3\mathbf{i} + 9\mathbf{j}$ $\mathbf{v} = 0$ $t = 12$ $\mathbf{v} = \mathbf{u} + \mathbf{a}t$ $0 = (3\mathbf{i} + 9\mathbf{j}) + 12\mathbf{a}$ $\mathbf{a} = (-\frac{1}{4}\mathbf{i} - \frac{3}{4}\mathbf{j}) \text{ m/s}^2$	MW1	
	(iii)	$\mathbf{P} = m\mathbf{a}$ $= -8(\frac{1}{4}\mathbf{i} + \frac{3}{4}\mathbf{j})$ $= -(2\mathbf{i} + 6\mathbf{j})\text{N}$	MW1	
	(iv)	$ \mathbf{P} = \sqrt{4 + 36} = \sqrt{40} \text{ N}$	MW1	5

3 (i)

Mass (kg)	Number of workers	Frequency density
3–10	16	2
11–20	(29)	2.9
21–25	(28)	(5.6)
26–40	(27)	1.8

MW1 (29, 27)

MW1 (28)

MW1 (5.6)

AVAILABLE MARKS

(ii)

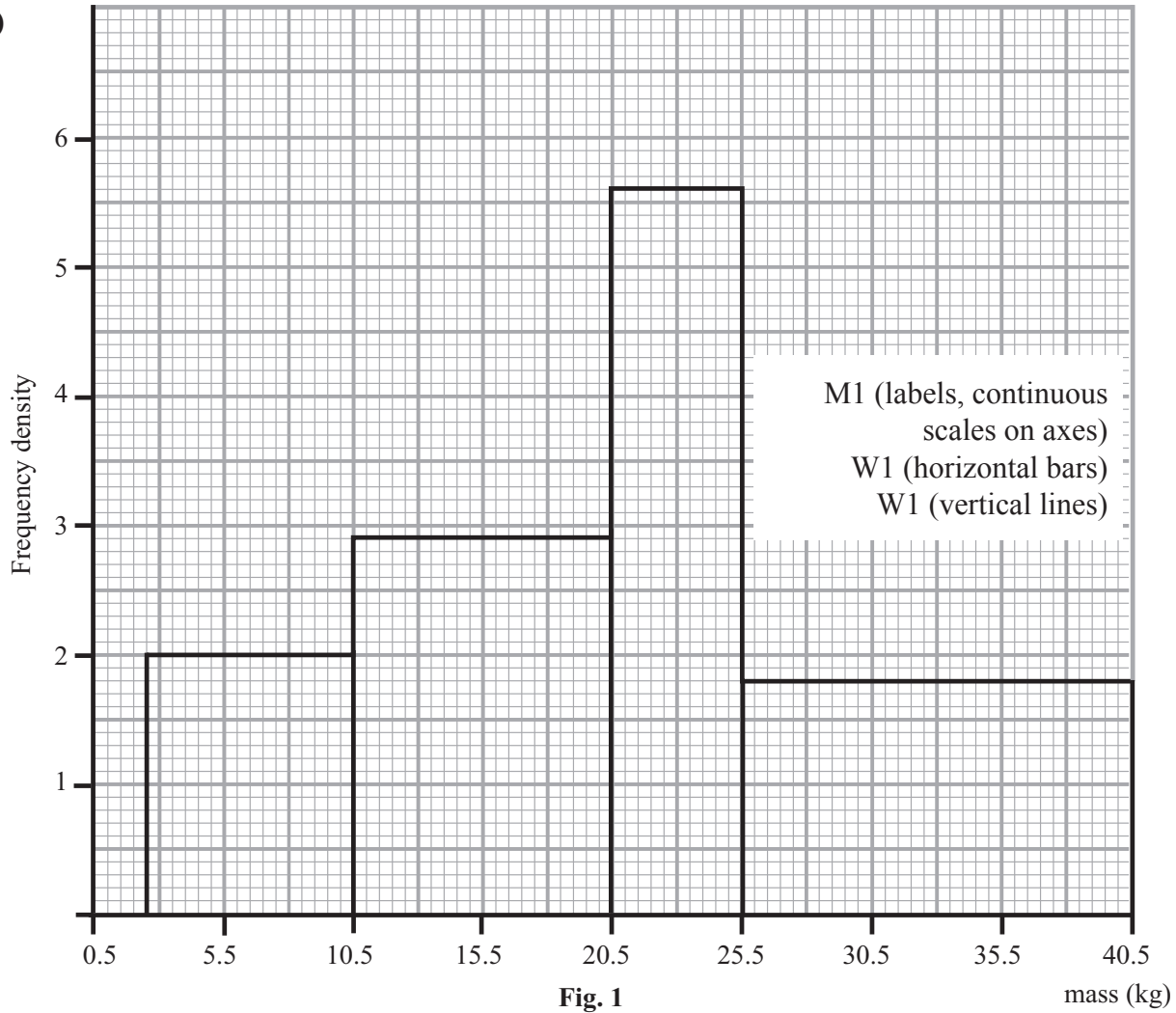

6

4 (i)

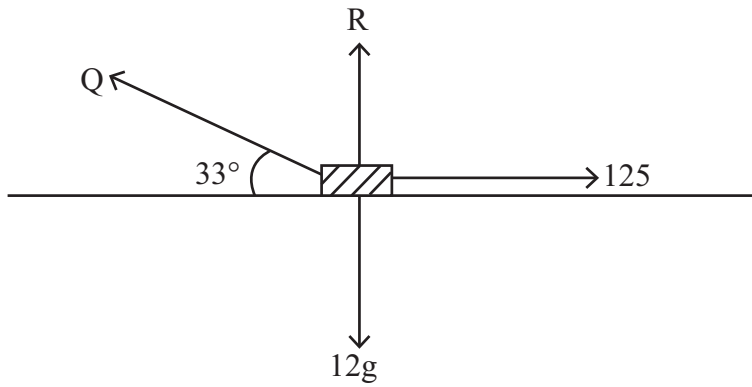

$$Q \cos 33 = 125$$

$$\therefore Q = 149 \text{ N}$$

MW1
W1

(ii) $Q \sin 33 + R = 120$
 $R = 38.8 \text{ N}$

MW1, MW1
W1

(iii) $125 - P = 12 \times 1.5$
 $\therefore P = 107 \text{ N}$

M1
W1

7

5 (a) (i) any appropriate example, e.g. number of pupils in class

M1

(ii) any appropriate example, e.g. heights of pupils in class

M1

(b) (i) 15

M1

(ii) $5 + \frac{48 - 8}{47} \times 10 = 13.5$

MW1 class
M1, W1 formula
W1 ans

7

Alternative solution

$$5 + \frac{47.5 - 8}{47} \times 10 = 13.4$$

M1
M1, W1
W1

			AVAILABLE MARKS
6 (i)	$u = 4.5$		
	$t = 6$		
	$s = 70.2$		
	$s = ut + \frac{1}{2}at^2$		
	$70.2 = 4.5 \times 6 + \frac{1}{2}a \times 36$	M1	
	$70.2 = 27 + 18a$		
	$a = 2.4 \text{ m/s}^2$	W1	
(ii)	$u = 4.5$		
	$a = 2.4$		
	$t = 6$		
	$v = u + at$		
	$v = 4.5 + 2.4 \times 6$	M1	
	$v = 18.9 \text{ m/s}$	W1	
(iii)	$u = 18.9$		
	$v = 23.7$		
	$a = 2.4$		
	$v^2 = u^2 + 2as$		
	$23.7^2 = 18.9^2 + 2 \times 2.4s$	M1	
	$s = 42.6 \text{ m}$	W1	
(iv)	$u = 18.9$		
	$v = 23.7$		
	$a = 2.4$		
	$v = u + at$		
	$23.7 = 18.9 + 2.4t$		
	$t = 2s$	MW1	7

7 (i) Use 5 point moving averages

- 114
- 117.4
- 120.8
- 124.4
- 129.2
- 132.2
- 135
- 141
- 143.6
- 146.8
- 150.8

AVAILABLE
MARKS

M1, W1

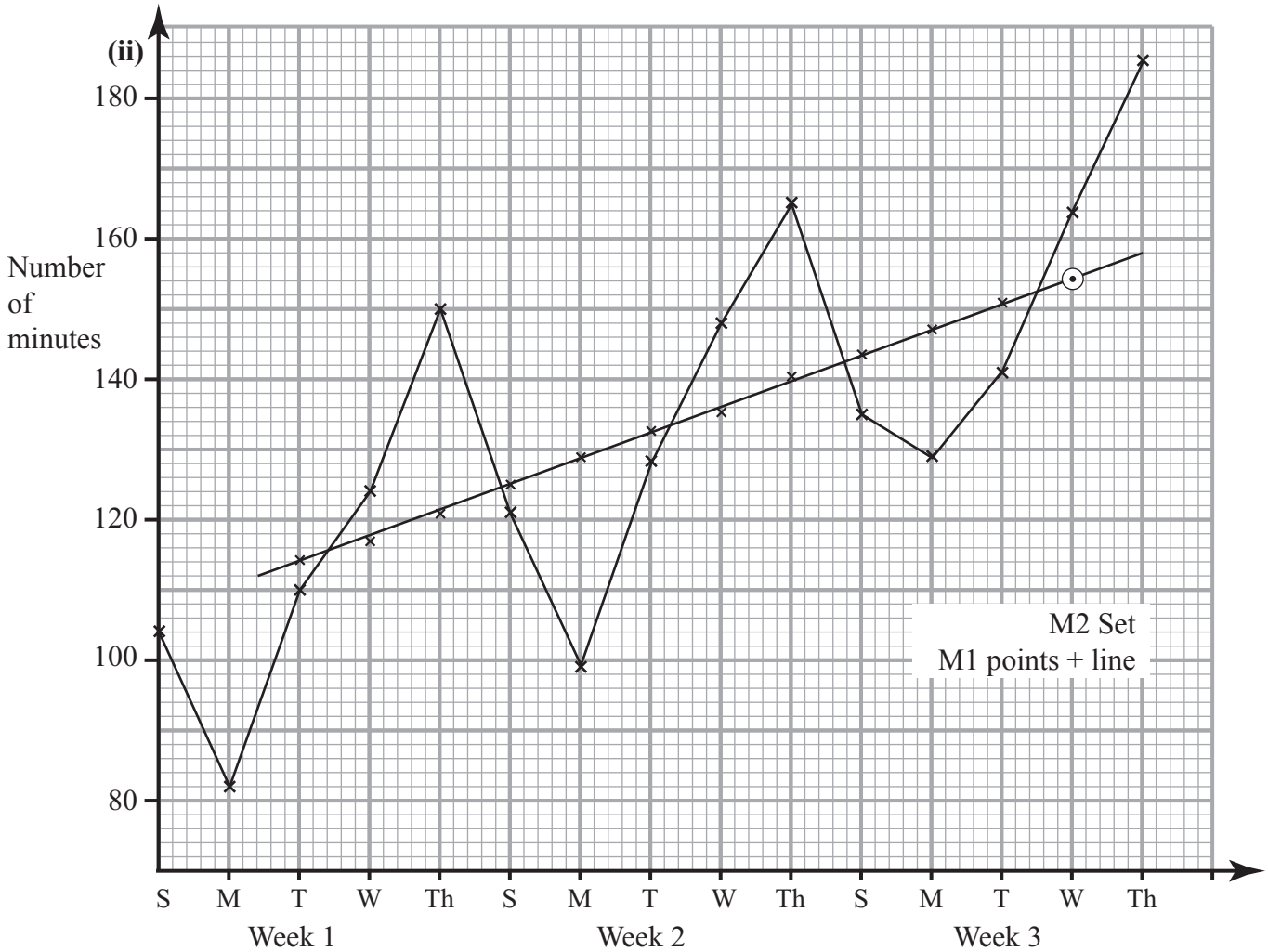

(iii) $154 = \frac{129 + 141 + 164 + 185 + x}{5}$

$x = 151$

so estimate of time spent = 151 minutes

M2 read

M1, W1

9

8 (i)

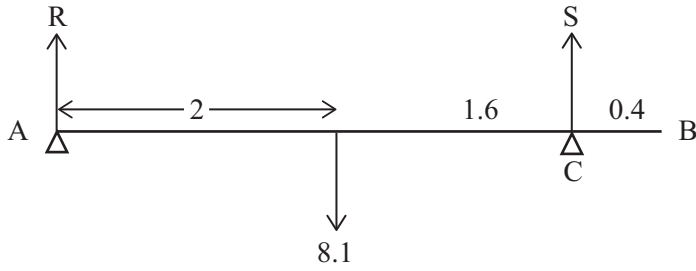

W2
(W1 for 2 correct)

(ii) Moments about A:

$$S \times 3.6 = 8.1 \times 2$$

M1

$$S = 4.5 \text{ N}$$

W1

Equating forces:

$$R + 4.5 = 8.1$$

$$R = 3.6 \text{ N}$$

MW1

(iii)

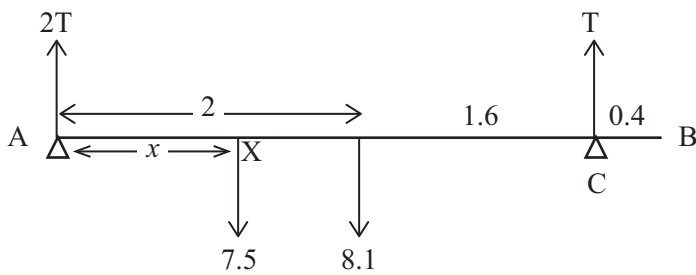

Let $T =$ reaction at C

Equating forces:

$$3T = 15.6$$

MW1

$$T = 5.2 \text{ N}$$

W1

(iv) Moments about A:

$$7.5x + 8.1 \times 2 = 5.2 \times 3.6$$

M1

$$7.5x = 2.52$$

$$x = 0.336 \text{ m}$$

W1

9

9 (i)

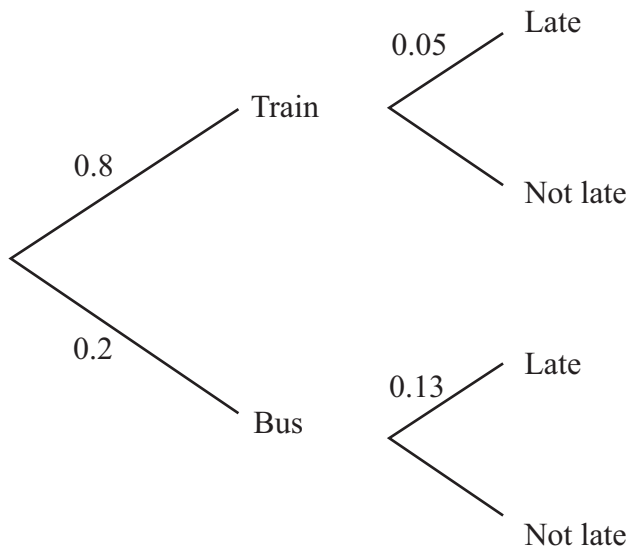

$$\begin{aligned} P(\text{late}) &= 0.8 \times 0.05 + 0.2 \times 0.13 \\ &= 0.066 \end{aligned}$$

M2
W1

$$\begin{aligned} \text{(ii) } P(\text{both late}) &= 0.066 \times 0.066 \\ &= 0.00436 \end{aligned}$$

M1
W1

$$\begin{aligned} \text{(iii) } 0.066 \times 13 \times 5 &= 4.29 \\ \therefore &\text{ expected to be late on 4 days} \end{aligned}$$

M1
W1

$$\begin{aligned} \text{(iv) } P(\text{train} \mid \text{late}) &= \frac{0.8 \times 0.05}{0.066} \\ &= 0.606 \quad \left(\text{or } \frac{20}{33} \right) \end{aligned}$$

M2
W1

AVAILABLE
MARKS

10

10 (i)

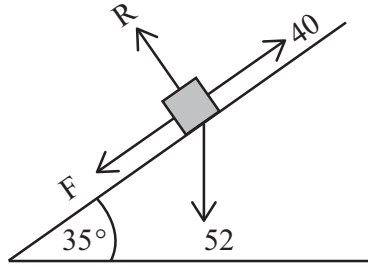

W2
(W1 for 2 or 3 correct forces)

(ii) $F + 52 \sin 35 = 40$
 $F = 40 - 52 \sin 35$
 $F = 10.174$

M1

W1

$R = 52 \cos 35$
 $R = 42.596$

MW1

$\mu = \frac{10.174}{42.596}$

$\mu = 0.239$ (to 3 d.p)

MW1

(iii)

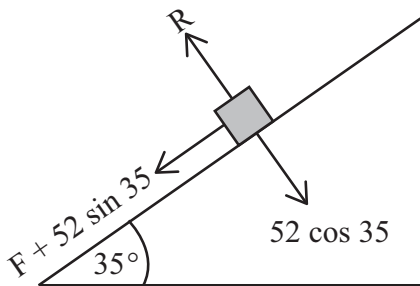

$F = ma$
 $-10.174 - 52 \sin 35 = 5.2a$
 $-40 = 5.2a$
 $a = -7.69 \text{ m/s}^2$

MW1, MW1

W1

(iv) $u = 2.5$
 $v = 0$
 $a = -7.69$

$v^2 = u^2 + 2as$
 $0 = 6.25 - 15.38x$
 $x = 0.41 \text{ m}$ (to 2 d.p)

M1

W1

AVAILABLE MARKS

11

11 (i) $u = 0$
 $v = 10$
 $s = 125$

$$v^2 = u^2 + 2as$$

$$100 = 0 + 250a$$

$$a = 0.4 \text{ m/s}^2$$

MW1

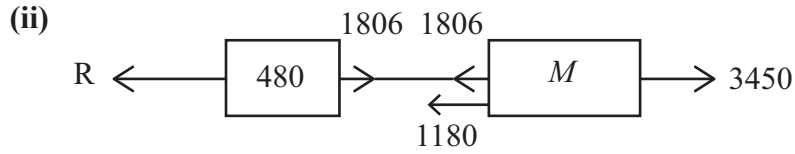

Van:

$$F = ma$$

$$3450 - 1806 - 1180 = 0.4M$$

$$464 = 0.4M$$

$$M = 1160 \text{ kg}$$

M1, M1

W1

(iii) Trailer:

$$F = ma$$

$$1806 - R = 0.4 \times 480$$

$$1806 - R = 192$$

$$R = 1614 \text{ N}$$

M1

W1

(iv) $u = 10$
 $t = 10$
 $s = 125$

$$s = ut + \frac{1}{2}at^2$$

$$125 = 100 + 50a$$

$$25 = 50a$$

$$a = 0.5 \text{ m/s}^2$$

MW1

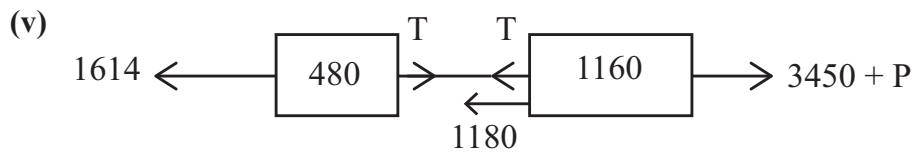

Trailer:

$$T - 1614 = 480 \times 0.5$$

$$T = 1854 \text{ N}$$

M1

W1

(vi) Van:

$$F = ma$$

$$3450 + P - T - 1180 = 1160 \times 0.5$$

$$3450 + P - 1854 - 1180 = 1160 \times 0.5$$

$$P = 164 \text{ N}$$

M1

W1

11

12 (i)

Ranks (Hazard)	5	8	2	6	7	1	3	4
Ranks (Theory)	4	5	1	6.5	8	3	2	6.5

or alternatively

Ranks (Hazard)	4	1	7	3	2	8	6	5
Ranks (Theory)	5	4	8	2.5	1	6	7	2.5

Ranks W2

(ii)

d^2	1	9	1	0.25	1	4	1	6.25
-------	---	---	---	------	---	---	---	------

$$\Sigma d^2 = 23.5$$

M1, W1

$$\text{Spearman's coefficient } 1 - \frac{6(23.5)}{8(63)} = 0.720$$

M1, W1

(iii) positive correlation

M1

(iv) mean hazard = 54.25, mean theory = 44.75

MW1

(v)

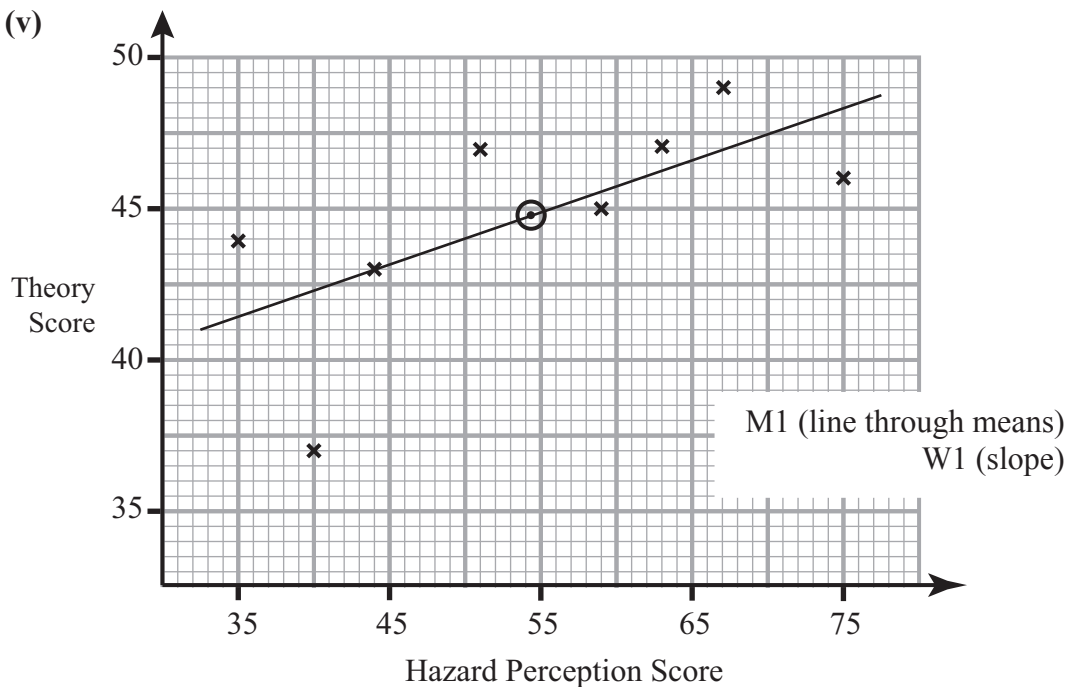

(vi) Gradient = $\frac{48.3 - 41.5}{75 - 35} = 0.17$

correct method M1

Using means

$$44.75 = 0.17 \times 54.25 + c$$

correct method M1

$$c = 35.5$$

Equation is $y = 0.17x + 35.5$

equation MW1

AVAILABLE MARKS

13

Total

100