

GENERAL CERTIFICATE OF SECONDARY EDUCATION
TWENTY FIRST CENTURY SCIENCE
ADDITIONAL APPLIED SCIENCE A
Communications (Higher Tier)

A326/02

Candidates answer on the Question Paper
A calculator may be used for this paper

OCR Supplied Materials:
None

Other Materials Required:

- Pencil
- Ruler (cm/mm)

Wednesday 27 January 2010
Afternoon

Duration: 45 minutes



Candidate Forename		Candidate Surname	
--------------------	--	-------------------	--

Centre Number						Candidate Number				
---------------	--	--	--	--	--	------------------	--	--	--	--

MODIFIED LANGUAGE

INSTRUCTIONS TO CANDIDATES

- Write your name clearly in capital letters, your Centre Number and Candidate Number in the boxes above.
- Use black ink. Pencil may be used for graphs and diagrams only.
- Read each question carefully and make sure that you know what you have to do before starting your answer.
- Answer **all** the questions.
- Do **not** write in the bar codes.
- Write your answer to each question in the space provided, however additional paper may be used if necessary.

INFORMATION FOR CANDIDATES

- The number of marks is given in brackets [] at the end of each question or part question.
- The marks allocated and the spaces provided for your answers are a good indication of the length of answers required.
- The total number of marks for this paper is **36**.
- This document consists of **12** pages. Any blank pages are indicated.

BLANK PAGE

PLEASE DO NOT WRITE ON THIS PAGE

Answer **all** the questions.

- 1 An office uses copper wire to link its fax machines to each other.



This is because copper wire is cheap and easy to use.
Other communication systems use radio waves.

- (a) Describe your own example of a different communication system that uses **radio waves** as the link.

.....
..... [1]

- (b) Explain why radio waves are the best link for your example.

.....
.....
..... [2]

- (c) Communication systems use different radio frequencies.
Put a **ring** around the frequency that best matches your example.

100 MHz 600 MHz 2 GHz 10 GHz

[1]

- (d) It is quite expensive to use radio waves as the link for a communication system.
Explain **another** disadvantage of using radio waves as the link.

.....
.....
.....
..... [2]

[Total: 6]
Turn over

- 2 Anita worries about burglars. She uses a video screen to view pictures from **three** cameras placed around her house.



- (a) Complete this block diagram for the system.

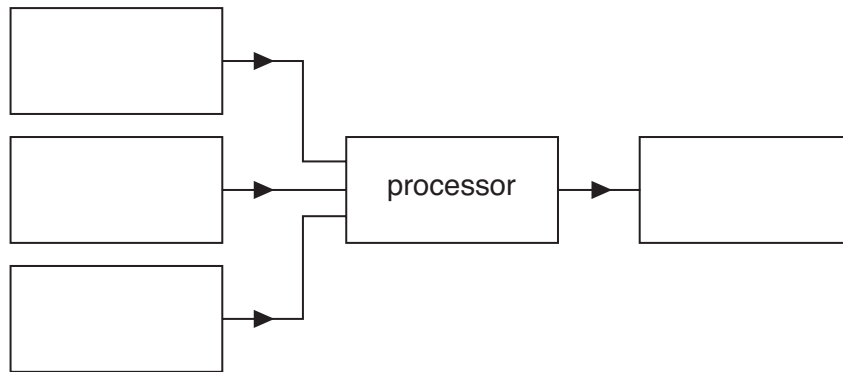

[1]

- (b) Complete the sentence.

Choose a word from this list.

current information light microwaves

The arrows in the diagram show the flow of from one block to another.

[1]

- (c) How is a circuit diagram different from a block diagram?

.....

[1]

(d) Here is some technical data for the video screen.

bits for each pixel	4
pixels per frame	65 536
frame refresh rate	32 per second

(i) Use the data to calculate the video bit rate for the cable leading to the screen.

video bit rate = bits per second [1]

(ii) Each row of the screen has 256 pixels.
How many bits of information are needed for each row of the screen?

information = bits [1]

[Total: 5]

- 3 Joe opens up a computer to inspect it. He sees two hazard symbols on the cover. This one tells him that there is a laser hazard.

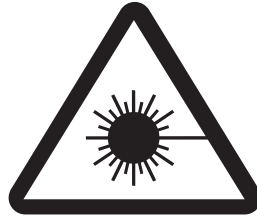

The other tells him of a high voltage hazard.

- (a) Draw the high voltage hazard symbol below.

[1]

- (b) He decides to use an **earth leakage device** to increase his safety. Explain how this makes him safer as he services the computer.

.....

.....

..... [2]

- (c) He makes copies of the digital files on the hard disc before he inspects the computer.

- (i) Give **two** examples of other devices which he could use to store the files.

1 2 [1]

- (ii) He **compresses** the files before storing them. Explain why he does this.

.....

.....

..... [2]

[Total: 6]

4 Here is the circuit diagram for a simple signalling system.

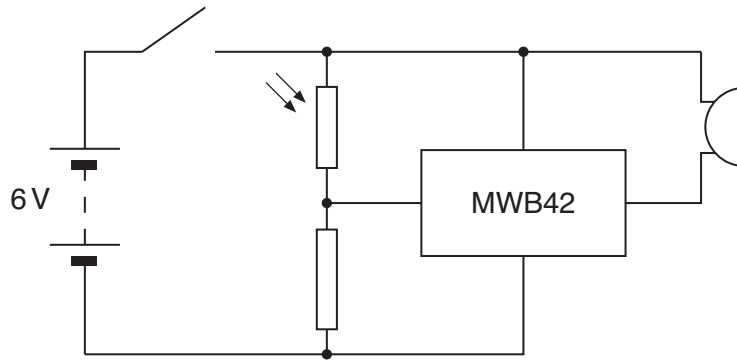

(a) Use the circuit diagram to complete this block diagram.

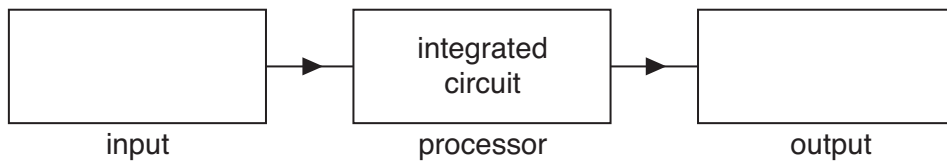

[2]

(b) The current in the integrated circuit is 0.20 A.
Explain why the current through the closed switch is **more** than 0.20 A.

.....

.....

..... [1]

(c) The maximum power rating of the integrated circuit is 1.8W.

(i) Calculate the maximum safe voltage of power supply for the integrated circuit.
Use $P = IV$. Assume the current is 0.20 A.

supply voltage = V [1]

(ii) Draw a voltmeter on the circuit diagram above to show how it should be connected to measure the voltage across the integrated circuit. [2]

[Total: 6]

5 This question is about the radio **transmitter** in a mobile phone.

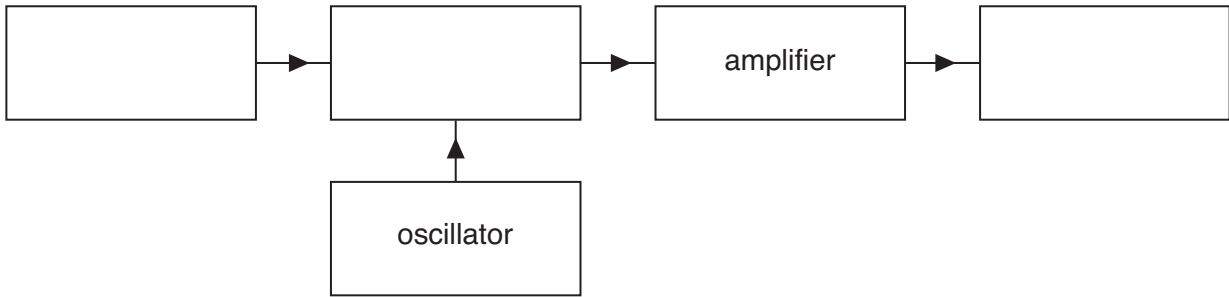

(a) Complete the block diagram for this radio **transmitter**. [3]

(b) Describe the function of the amplifier.

.....

 [2]

(c) Mobile phone transmissions use a digital format.
 This allows analogue voice signals to be encrypted.

(i) Suggest why voice signals are **encrypted**.

.....
 [1]

(ii) The sentences describe how the analogue voice signal is converted into a digital format.
 Complete the sentences. Choose the correct words from this list.

sampled **encoded** **decoded** **compressed**

The analogue voice signal is many times each second.

The voltage of the signal is as a binary word. [2]

[Total: 8]

6 Sue uses her computer to communicate over large distances through the internet.

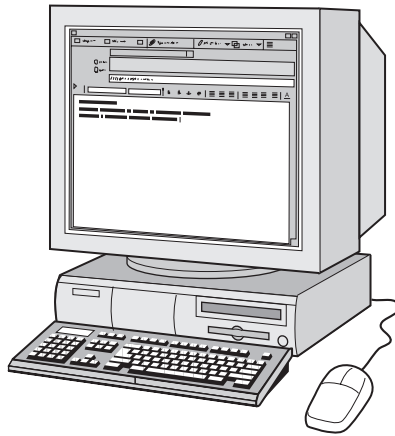

(a) (i) Name the **input device** for a computer.
..... [1]

(ii) State what the input device does to information before transferring it onto the computer.
.....
..... [1]

(b) Explain the meaning of these terms as they apply to the internet.

(i) data transmission rate
.....
.....
..... [1]

(ii) error rate
.....
.....
..... [1]

(iii) range
.....
.....
..... [1]

[Total: 5]

END OF QUESTION PAPER

10
BLANK PAGE

PLEASE DO NOT WRITE ON THIS PAGE

11
BLANK PAGE

PLEASE DO NOT WRITE ON THIS PAGE

PLEASE DO NOT WRITE ON THIS PAGE



Copyright Information

OCR is committed to seeking permission to reproduce all third-party content that it uses in its assessment materials. OCR has attempted to identify and contact all copyright holders whose work is used in this paper. To avoid the issue of disclosure of answer-related information to candidates, all copyright acknowledgements are reproduced in the OCR Copyright Acknowledgements Booklet. This is produced for each series of examinations, is given to all schools that receive assessment material and is freely available to download from our public website (www.ocr.org.uk) after the live examination series.

If OCR has unwittingly failed to correctly acknowledge or clear any third-party content in this assessment material, OCR will be happy to correct its mistake at the earliest possible opportunity.

For queries or further information please contact the Copyright Team, First Floor, 9 Hills Road, Cambridge CB2 1GE.

OCR is part of the Cambridge Assessment Group; Cambridge Assessment is the brand name of University of Cambridge Local Examinations Syndicate (UCLES), which is itself a department of the University of Cambridge.