

Q.1 – Q.30 Carry One Mark Each

1. The value of Z in Figure.Q.1, which is most appropriate to cause parallel resonance at 500 Hz, is

- (a) 125.00 mH
- (b) 304.20 μ F
- (c) 2.0 μ F
- (d) 0.05 μ F

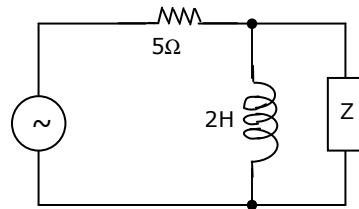

2. A parallel plate capacitor is shown in figure Q.2. It is made of two square metal plates of 400 mm side. The 14 mm space between the plates is filled with two layers of dielectrics of $\epsilon_r = 4, 6$ mm thick and $\epsilon_r = 2, 8$ mm thick. Neglecting fringing of fields at the edges the capacitance is

- (a) 1298 pF
- (b) 944 pF
- (c) 354 pF
- (d) 257 pF

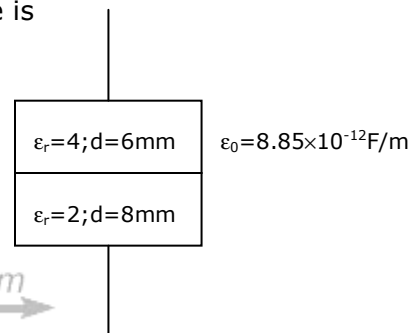

3. The inductance of a long solenoid of length 1000 mm wound uniformly with 3000 turns on a cylindrical paper tube of 60mm diameter is

- (a) 3.2 μ H
- (b) 3.2 mH
- (c) 32.0 mH
- (d) 3.2 H

4. Total instantaneous power supplied by a 3-phase ac supply to a balanced R-L load is

- (a) zero
- (b) constant
- (c) pulsating with zero average
- (d) pulsating with non-zero average

5. A 500 kVA, 3-phase transformer has iron losses of 300 W and full load copper losses of 600 W. The percentage load at which the transformer is expected to have maximum efficiency is

- (a) 50.0%
- (b) 70.7%
- (c) 141.4%
- (d) 200.0%

6. For a given stepper motor, the following torque has the highest numerical value.

- (a) Detent torque
- (b) Pull-in torque
- (c) Pull-out torque
- (d) Holding torque

Join All India Mock GATE Classroom Test Series - 2007 conducted by GATE Forum in over 25 cities all over India. Question Papers including section tests and full tests are designed by IISc alumni according to the latest syllabus. Percentile, All India Rank, interaction with IISc alumni in our online discussion forums, and more. For more details, visit

7. The following motor definitely has a permanent magnet rotor
 - (a) DC commutator motor
 - (b) Brushless dc motor
 - (c) Stepper motor
 - (d) Reluctance motor

8. The type of single-phase induction motor having the highest power factor at full load is
 - (a) shaded pole type
 - (b) split-phase type
 - (c) capacitor-start type
 - (d) capacitor-run type

9. The direction of rotation of a 3-phase induction motor is clockwise when it is supplied with 3-phase sinusoidal voltage having phase sequence A-B-C. For counter clockwise rotation of the motor, the phase sequence of the power supply should be
 - (a) B-C-A
 - (b) C-A-B
 - (c) A-C-B
 - (d) B-C-A or C-A-B

10. For a linear electromagnetic circuit, the following statement is true.
 - (a) Field energy is equal to the co-energy
 - (b) Field energy is greater than the co-energy
 - (c) Field energy is lesser than the co-energy
 - (d) Co-energy is zero

11. The rated voltage of a 3-phase power system is given as
 - (a) rms phase voltage
 - (b) peak phase voltage
 - (c) rms line to line voltage
 - (d) peak line to line voltage

12. The phase sequence of the 3-phase system shown in Figure is

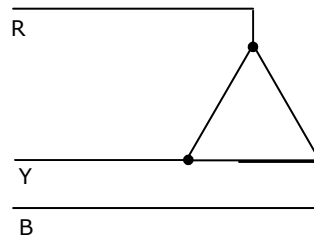

- (a) RYB
 - (b) RBY
 - (c) BRY
 - (d) YBR
13. In thermal power plants, the pressure in the working fluid cycle is developed by
- (a) condenser
 - (b) super heater
 - (c) feed water pump
 - (d) turbine

14. For harnessing low variable water heads, the suitable hydraulic turbine with percentage of reaction and runner adjustable vanes is
 (a) Kaplan (b) Francis (c) Pelton (d) Impeller
15. The transmission line distance protection relay having the property of being inherently directional is
 (a) impedance relay (b) MHO relay
 (c) OHM relay (d) reactance relay

16. The current through the Zener diode in figure is

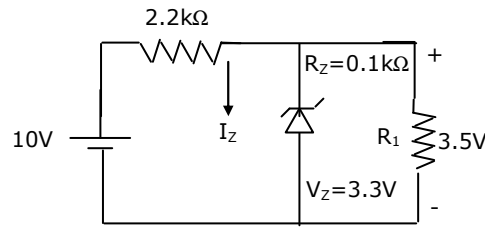

- (a) 33 mA (b) 3.3 mA (c) 2 mA (d) 0 mA

17. Two perfectly matched silicon transistors are connected as shown in figure. The value of the current I is

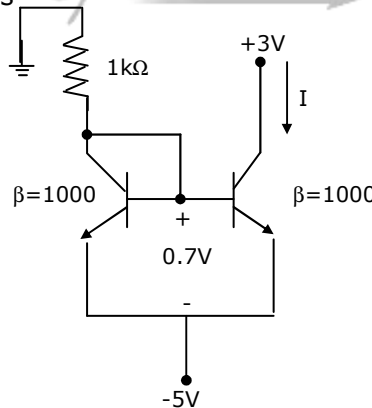

- (a) 0 mA (b) 2.3 mA (c) 4.3 mA (d) 7.3 mA

18. The feedback used in the circuit shown in figure can be classified as

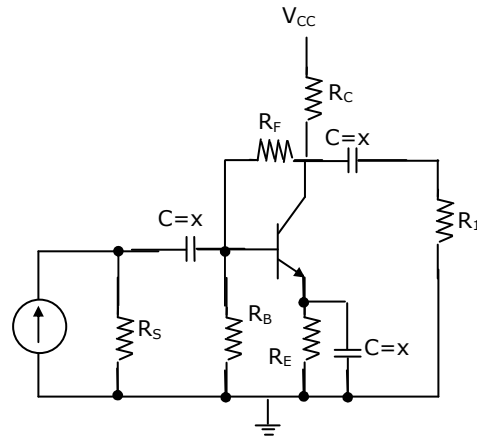

- (a) shunt-series feedback (b) shunt-shunt feedback
(c) series-shunt feedback (d) series-series feedback

19. The digital circuit using two inverters shown in figure will act as

- (a) a bistable multi-vibrator
(b) an astable multi-vibrator
(c) a monostable multi-vibrator
(d) an oscillator

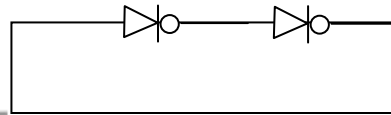

20. The voltage comparator shown in figure can be used in the analog-to-digital conversion as

- (a) a 1-bit quantizer
(b) a 2-bit quantizer
(c) a 4-bit quantizer
(d) a 8-bit quantizer

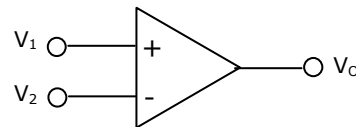

21. The Nyquist plot of loop transfer function $G(s)H(s)$ of a closed loop control system passes through the point $(-1, j0)$ in the $G(s)H(s)$ plane. The phase margin of the system is

- (a) 0° (b) 45° (c) 90° (d) 180°

22. Consider the function $F(s) = \frac{5}{s(s^2 + 3s + 2)}$, where $F(s)$ is the Laplace transform

of the function $f(t)$. the initial value of $f(t)$ is equal to

- (a) 5 (b) $\frac{5}{2}$ (c) $\frac{5}{3}$ (d) 0

23. For a tachometer if $\theta(t)$ is the rotor displacement in radians, $e(t)$ is the induced voltage and K_t is the tachometer constant in V/rad/sec, then the transfer function, $\frac{E(s)}{\Theta(s)}$ will be

(a) $K_t s^2$ (b) $\frac{K_t}{s}$ (c) $K_t s$ (d) K_t

24. A dc potentiometer is designed to measure up to about 2V with a slide wire of 300 mm. A standard cell of emf 1.18 V obtains balance at 600 mm. A test cell is seen to obtain balance at 680 mm. The emf of the test cell is

(a) 1.00 V (b) 1.34 V (c) 1.50 V (d) 1.70 V

25. The circuit in figure is used to measure the power consumed by the load. The current coil and the voltage coil of the wattmeter have 0.02Ω and 1000Ω resistances respectively. The measured power compared to the load power will be

(a) 0.4% less
(b) 0.2% less
(c) 0.2% more
(d) 0.4% more

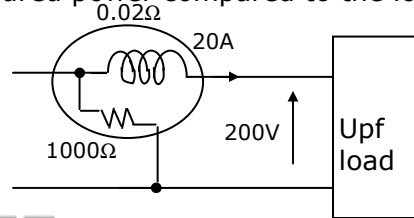

26. A galvanometer with a full-scale current of 10mA has a resistance of 1000Ω . The multiplying power (the ratio of measured current to galvanometer current) of a 100Ω shunt with this galvanometer is

(a) 110 (b) 100 (c) 11 (d) 10

27. A bipolar junction transistor (BJT) is used as a power control switch by biasing it in the cut-off region (OFF state) or in the saturation region (ON state). In the ON state, for the BJT

(a) both the base-emitter and base-collector junctions are reverse biased
(b) the base-emitter junction is reverse biased, and the base-collector junction is forward biased
(c) the base-emitter junction is forward biased, and the base-collector junction is reverse biased
(d) both the base-emitter and base-collector junctions are forward biased

28. The circuit in figure shows a full-wave rectifier. The input voltage is 230V (rms) single-phase ac. The peak reverse voltage across the diodes D1 and D2 is

(a) $100\sqrt{2}$ V
(b) 100 V
(c) $50\sqrt{2}$ V
(d) 50 V

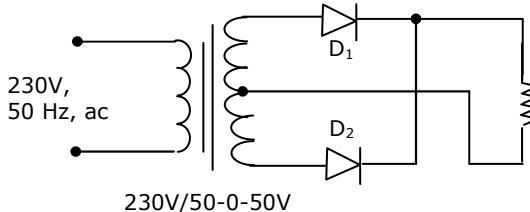

29. The triggering circuit of a thyristor is shown in figure. The thyristor requires a gate current of 10 mA, for guaranteed turn-on. The value of R required for thyristor to turn on reliably under all conditions of V_b variation is

- (a) 10000Ω
(b) 1600Ω
(c) 1200Ω
(d) 800Ω

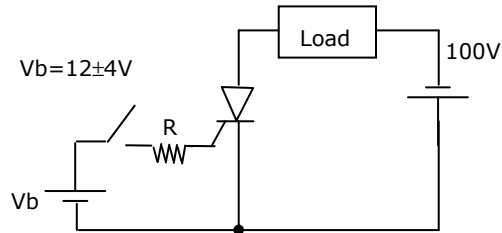

30. The circuit in figure shows a 3-phase half-wave rectifier. The source is a symmetrical, 3-phase four-wire system. The line-to-line voltage of the source is 100 V. The supply frequency is 400 Hz. The ripple frequency at the output is

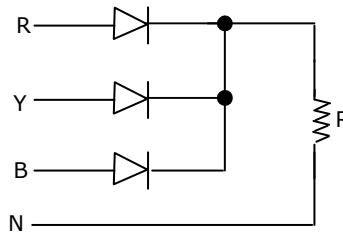

- (a) 400 Hz (b) 800 Hz (c) 1200 Hz (d) 2400 Hz

Question No.31 to 90 Carry 2 Marks Each.

31. The rms value of the periodic waveform given in figure is

- (a) $2\sqrt{6}$ A
(b) $6\sqrt{2}$ A
(c) $\sqrt{\frac{4}{3}}$ A
(d) 1.5 A

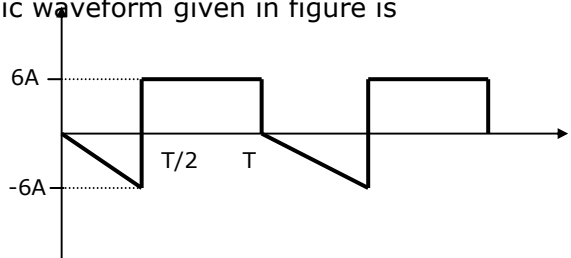

32. In figure, the value of the source voltage is

- (a) 12 V
(b) 24 V
(c) 30 V
(d) 44 V

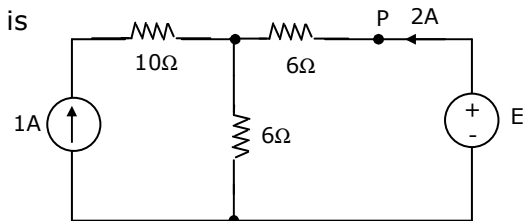

33. In figure, R_a , R_b and R_c are 20Ω , 10Ω and 10Ω respectively. The resistances R_2 and R_3 in Ω of an equivalent star-connection are

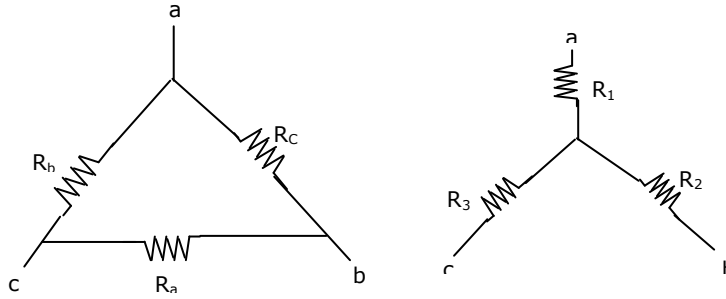

- (a) 2.5, 5, 5 (b) 5, 2.5, 5 (c) 5, 5, 2.5 (d) 2.5, 5, 2.5

34. In figure, the admittance values of the elements in Siemens are $Y_R = 0.5 + j0$, $Y_1 = 0 - j1.5$, $Y_C = 0 + j0.3$ respectively. The value of I as a phasor when the voltage E across the elements is $10\angle 0^\circ V$ is

- (a) $1.5 + j0.5$
(b) $5 - j18$
(c) $0.5 + j1.8$
(d) $5 - j12$

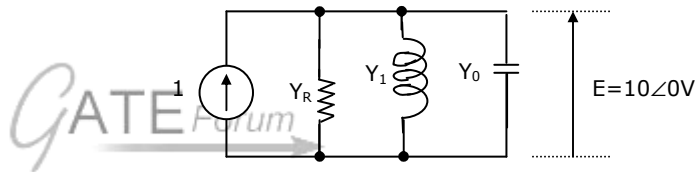

35. In figure, the value of resistance R in Ω is

- (a) 10 (b) 20
(c) 30 (d) 40

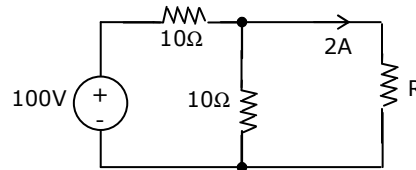

36. In figure, the capacitor initially has a charge of 10 Coulomb. The current in the circuit one second after the switch S is closed will be

- (a) 14.7 A
(b) 18.5 A
(c) 40.0 A
(d) 50.0 A

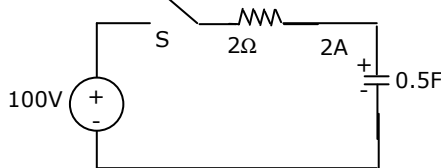

37. The rms value of the resultant current in a wire which carries a dc current of 10 A and a sinusoidal alternating current of peak value 20 A is

- (a) 14.1 A (b) 17.3 A (c) 22.4 A (d) 30.0 A

38. The Z matrix of a 2-port network as given by

$$\begin{bmatrix} 0.9 & 0.2 \\ 0.2 & 0.6 \end{bmatrix}$$

- The element Y_{22} of the corresponding Y matrix of the same network is given by
 (a) 1.2 (b) 0.4 (c) -0.4 (d) 1.8
39. The synchronous speed for the seventh space harmonic mmf wave of a 3-phase, 8 pole, 50 Hz induction machine is
 (a) 107.14 rpm in forward direction (b) 107.14 rpm in reverse direction
 (c) 5250 rpm in forward direction (d) 5250 rpm in reverse direction
40. A rotating electrical machine having its self-inductances of both the stator and the rotor windings, independent of the rotor position will be definitely not develop
 (a) starting torque (b) synchronizing torque
 (c) hysteresis torque (d) reluctance torque
41. The armature resistance of a permanent magnet dc motor is 0.8Ω . At no load, the motor draws 1.5 A from a supply voltage of 25 V and runs at 1500 rpm. The efficiency of the motor while it is operating on load at 1500 rpm drawing a current of 3.5 A from the same source will be
 (a) 48.0% (b) 57.1% (c) 59.2% (d) 88.8%
42. A 50 kVA, 3300/230V single-phase transformer is connected as an autotransformer shown in figure. The nominal rating of the autotransformer will be
 (a) 50.0 kVA
 (b) 53.5 kVA
 (c) 717.4 kVA
 (d) 767.4 kVA

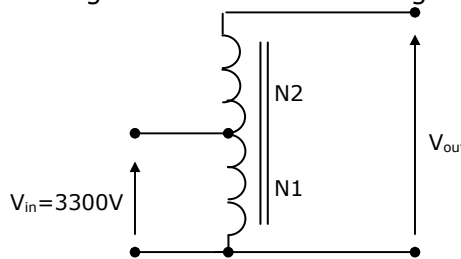

43. The resistance and reactance of a 100 kVA 11000/400V, Δ -Y distribution transformer are 0.02 and 0.07 pu respectively. The phase impedance of the transformer referred to the primary is
 (a) $(0.02 + j0.07)\Omega$ (b) $(0.55 + j1.925)\Omega$
 (c) $(15.125 + j52.94)\Omega$ (d) $(72.6 + j254.1)\Omega$
44. A single-phase, 230 V, 50 Hz, 4 pole, capacitor-start induction motor has the following stand still impedances
 Main winding $Z_m = 6.0 + j4.0\Omega$
 Auxiliary winding $Z_a = 8.0 + j6.0\Omega$

- The value of the starting capacitor required to produce 90° phase difference between the currents in the main and auxiliary windings will be
 (a) $176.84 \mu\text{F}$ (b) $187.24 \mu\text{F}$ (c) $265.26 \mu\text{F}$ (d) $280.86 \mu\text{F}$
45. Two 3-phase, Y-connected alternators are to be paralleled to a set of common bus bars. The armature has a per phase synchronous reactance of 1.7Ω and negligible armature resistance. The line voltage of the first machines is adjusted to 3300 V and that of the second machine is adjusted to 3200 V. the machine voltages are in phase at the instant they are paralleled. Under this condition, the synchronizing current per phase will be
 (a) 16.98 A (b) 29.41 A (c) 33.96 A (d) 58.82 A
46. A 400V, 15 kW, 4 pole, 50 Hz, Y-connected induction motor has full load slip of 4%. The output torque of the machine at full load is
 (a) 1.66 Nm (b) 95.50 Nm (c) 99.47 Nm (d) 624.73 Nm
47. For a 1.8° , 2-phase bipolar stepper motor, the stepping rate is 100 steps/second. The rotational speed of the motor in rpm is
 (a) 15 (b) 30 (c) 60 (d) 90
48. A 8 pole, DC generator has a simplex wave-wound armature containing 32 coils of 6 turns each. Its flux per pole is 0.06 Wb. The machine is running at 250 rpm. The induced armature voltage is
 (a) 96V (b) 192V (c) 384V (d) 768V
49. A 400V, 50 kVA, 0.8 pf leading Δ -connected, 50 Hz synchronous machine has a synchronous reactance of 2Ω and negligible armature resistance. The friction and windage losses are 2kW and the core loss is 0.8 kW. The shaft is supplying 9kW load at a power factor of 0.8 leading. The line current drawn is
 (a) 12.29 A (b) 16.24 A (c) 21.29 A (d) 36.88 A
50. A 500 MW 3-phase Y-connected synchronous generator has a rated voltage of 21.5 kV at 0.85 pf. The line current when operating at full load rated conditions will be
 (a) 13.43 kA (b) 15.79 kA (c) 23.25 kA (d) 27.36 kA
51. A 800 kV transmission line is having per phase line inductance of 1.1 mH/km and per phase line capacitance of 11.68 nF/km. Ignoring the length of the line, its ideal power transfer capability in MW is
 (a) 1204 MW (b) 1504 MW (c) 2085 MW (d) 2606 MW

52. A 110 kV, single core coaxial, XLPE insulated power cable delivering power at 50 Hz, has a capacitance of 125 nF/km. If the dielectric loss tangent of XLPE is 2×10^{-4} , the dielectric power loss in this cable in W/km is
 (a) 5.0 (b) 31.7 (c) 37.8 (d) 189.0
53. A lightning stroke discharges impulse current of 10 kA (peak) on a 400 kV transmission line having surge impedance of 250 Ω . The magnitude of transient over-voltage traveling waves in either direction assuming equal distribution from the point of lightning strike will be
 (a) 1250kV (b) 1650 kV (c) 2500 kV (d) 2900kV
54. The generalized circuit constants of a 3-phase, 220 kV rated voltage, medium length transmission line are
 $A = D = 0.936 + j0.016 = 0.936 \angle 0.98^\circ$
 $B = 33.5 + j138 = 142.0 \angle 76.4^\circ \Omega$
 $C = (-5.18 + j914) \times 10^{-6} \Omega$
 If the load at the receiving end is 50 MW at 220 kV with a power factor of 0.9 lagging, the magnitude of line to line sending end voltage should be
 (a) 133.23 kV (b) 220.00 kV (c) 230.78 kV (d) 246.30 kV
55. A new generator having $E_g = 1.4 \angle 30^\circ$ pu [equivalent to $(1.212 + j0.70)$ pu] and synchronous reactance ' X_s ' of 1.0 pu on the system base, is to be connected to a bus having voltage V_t in the existing power system. This existing power system can be represented by Thevenin's voltage $E_{th} = 0.9 \angle 0^\circ$ pu in series with Thevenin's impedance $Z_{th} = 0.25 \angle 90^\circ$ pu. The magnitude of the bus voltage V_t of the system in pu will be
 (a) 0.990 (b) 0.973 (c) 0.963 (d) 0.900
56. A 3-phase generator rated at 110MVA, 11 kV is connected through circuit breakers to a transformer. The generator is having direct axis sub-transient reactance $X_d'' = 19\%$, transient reactance $X_d' = 26\%$ and synchronous reactance $X_d = 130\%$. The generator is operating at no load and rated voltage when a three-phase short circuit fault occurs between the breakers and the transformer. The magnitude of initial symmetrical rms current in the breakers will be
 (a) 4.44 kA (b) 22.20 kA (c) 30.39 kA (d) 38.45 kA

57. A 3-phase transmission line supplies Δ -connected load Z . The conductor 'c' of the line develops an open circuit fault as shown in figure. The currents in the lines are as shown on the diagram. The positive sequence current component in line 'a' will be
- (a) $5.78 \angle -30^\circ$ (b) $5.78 \angle 90^\circ$
 (c) $6.33 \angle 90^\circ$ (d) $10.00 \angle -30^\circ$

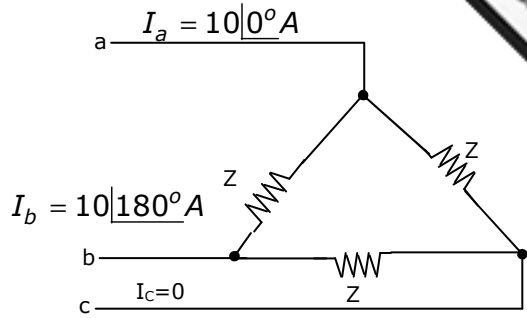

58. A 500 MVA, 50 Hz, 3-phase turbo-generator produces power at 22 kV. Generator is Y-connected and its neutral is solidly grounded. Their sequence reactances are $X_1 = X_2 = 0.15$ and $X_0 = 0.05 pu$. It is operating at rated voltage and disconnected from the rest of the system (no load). The magnitude of the sub-transient line current for single line ground fault at the generator terminal in pu will be
- (a) 2.851 (b) 3.333 (c) 6.667 (d) 8.553
59. A 50 Hz, 4-pole, 500 MVA, 22 kV turbo-generator is delivering rated megavolt-amperes at 0.8 power factor. Suddenly a fault occurs reducing its electric power output by 40%. Neglect losses and assume constant power input to the shaft. The accelerating torque in the generator in MNm at the time of the fault will be
- (a) 1.528 (b) 1.018 (c) 0.848 (d) 0.509
60. A hydraulic turbine having rated speed of 250 rpm is connected to a synchronous generator. In order to produce power at 50 Hz, the number of poles required in the generator are
- (a) 6 (b) 12 (c) 16 (d) 24
61. Assuming that the diodes are ideal in figure, the current in D_1 is
- (a) 8 mA
 (b) 5 mA
 (c) 0 mA
 (d) -3 mA

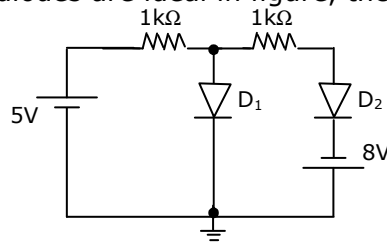

62. The transconductance g_m of the transistor shown in figure is 10 mS. The value of the input resistance R_{IN} is
- (a) 10.0 k Ω
 (b) 8.3 k Ω
 (c) 5.0 k Ω
 (d) 2.5 k Ω

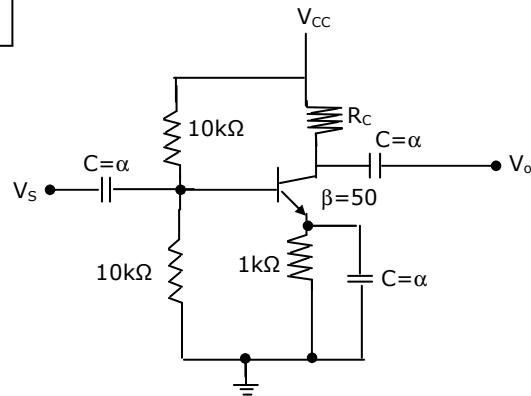

63. The value of R for which the PMOS transistor in figure will be biased in region is

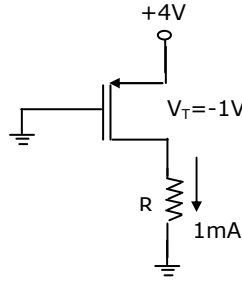

- (a) 220 Ω (b) 470 Ω (c) 680 Ω (d) 1200 Ω

64. In the active filter circuit shown in figure, if $Q=1$, a pair of poles will be realized with ω_0 equal to

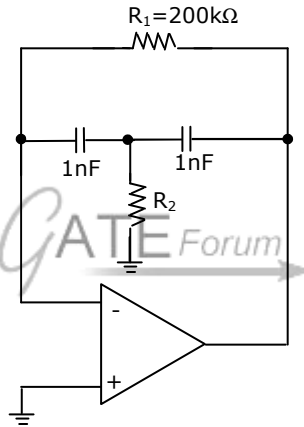

- (a) 1000 rad/s (b) 100 rad/s (c) 10 rad/s (d) 1 rad/s

65. The input resistance $R_{IN} \left(= \frac{V_x}{i_x} \right)$ of the circuit in figure is

- (a) +100k Ω
(b) -100k Ω
(c) +1 M Ω
(d) - 1 M Ω

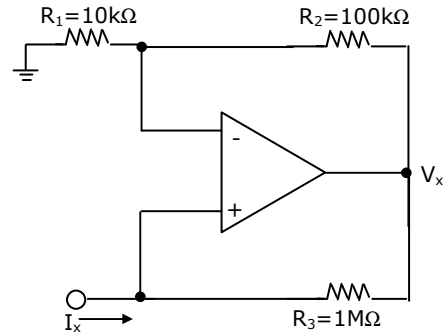

66. The simplified form of the Boolean expression $Y = (\overline{A}.BC + D)(\overline{A}.D + \overline{B}.C)$ can be written as
- (a) $\overline{A}.D + \overline{B}.C.D$ (b) $AD + B.C.D$
(c) $(\overline{A} + D)(\overline{B}.C + \overline{D})$ (d) $A.\overline{D} + BC.\overline{D}$

67. A digital circuit, which compares two numbers, $A_3, A_2, A_1, A_0, B_3, B_2, B_1, B_0$ is shown in figure. To get output $Y=0$, choose one pair of correct input numbers.

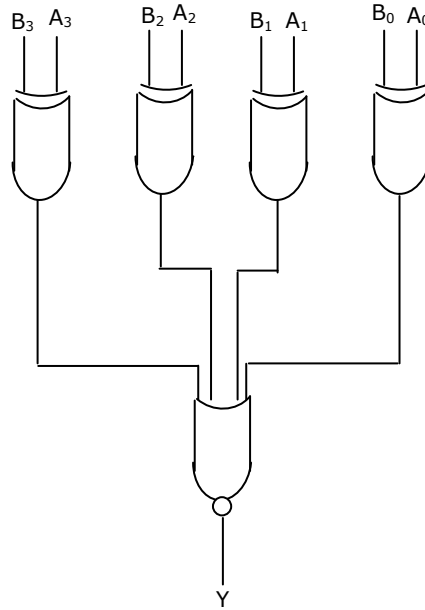

- (a) 1010, 1010 (b) 0101, 0101 (c) 0010, 0010 (d) 0010, 1011

68. The digital circuit shown in figure generates a modified clock pulse at the output. Choose the correct output waveform from the options given below.

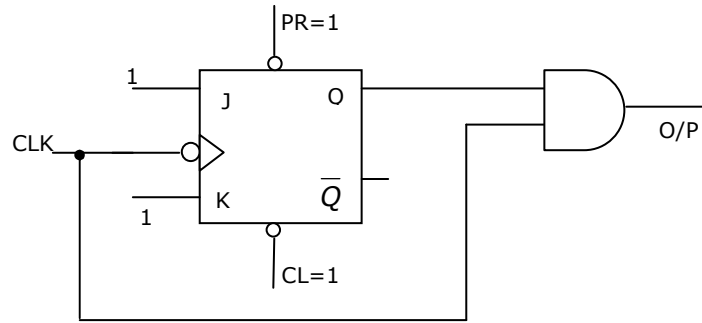

- (a) (b)
- (c) (d)

69. In the Schmitt trigger circuit shown in figure, if $V_{CE(sat)} = 0.1V$, the output logic low level (V_{OL}) is
- 1.25 V
 - 1.35 V
 - 2.50 V
 - 5.00 V

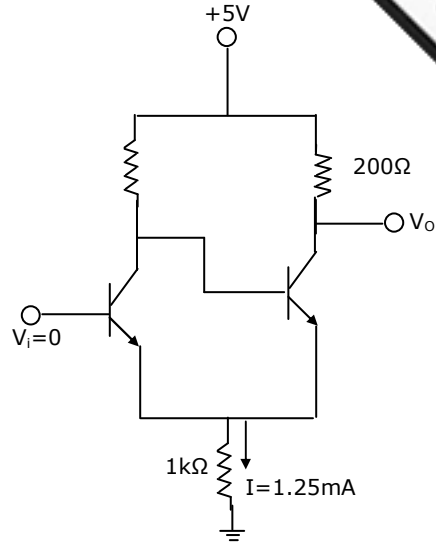

70. If the following program is executed in a microprocessor, the number of instruction cycles it will take from START TO HALT is

START MV1A, 14 H	:	Move 14 H to register A
SHIFT RLC	:	Rotate left without carry
JNZ SHIFT	:	Jump on non-zero to SHIFT
HALT	:	

- 4
 - 8
 - 13
 - 16
71. For the equation, $s^3 - 4s^2 + s + 6 = 0$, the number of roots in the left half of s-plane will be
- zero
 - one
 - two
 - three

72. For the block diagram shown in figure, the transfer function $\frac{C(s)}{R(s)}$ is equal to

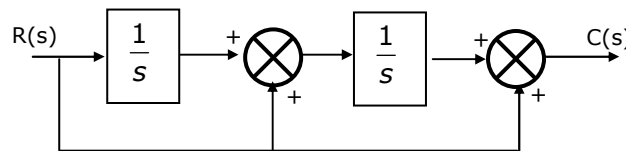

- $\frac{s^2 + 1}{s^2}$
- $\frac{s^2 + s + 1}{s^2}$
- $\frac{1}{s^2 + s + 1}$
- $\frac{s^2 + s + 1}{s}$

73. The state variable description of a linear autonomous system is $\dot{X} = AX$, where X is the two dimensional state vector and A is the system matrix given by $A = \begin{bmatrix} 0 & 2 \\ 2 & 0 \end{bmatrix}$. The roots of the characteristic equation are
- (a) -2 and +2 (b) -j2 and +j2 (c) -2 and -2 (d) +2 and -2

74. The block diagram of a closed loop control system is given by figure. The values of K and P such that the system has a damping ratio of 0.7 and an undamped natural frequency ω_n of 5 rad/sec, are respectively equal to
- (a) 20 and 0.3
(b) 20 and 0.2
(c) 25 and 0.3
(d) 25 and 0.2

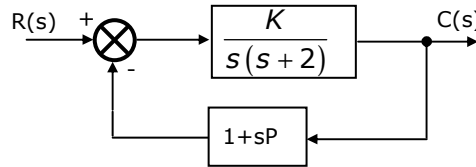

75. The unit impulse response of a second order under-damped system starting from rest is given by $c(t) = 12.5e^{-6t} \sin 8t, t \geq 0$
- The steady-state value of the unit step response of the system is equal to
- (a) 0 (b) 0.25 (c) 0.5 (d) 1.0

76. In the system shown in figure, the input $x(t) = \sin t$. In the steady-state, the response $y(t)$ will be

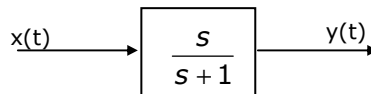

- (a) $\frac{1}{\sqrt{2}} \sin(t - 45^\circ)$ (b) $\frac{1}{\sqrt{2}} \sin(t + 45^\circ)$ (c) $\sin(t - 45^\circ)$ (d) $\sin(t + 45^\circ)$
77. The open loop transfer function of a unity feedback control system is given as $G(s) = \frac{as + 1}{s^2}$.
- The value of 'a' to give a phase margin of 45° is equal to
- (a) 0.141 (b) 0.441 (c) 0.841 (d) 1.141

78. A CRO probe has an impedance of $500\text{ k}\Omega$ in parallel with a capacitance of 10 pF . The probe is used to measure the voltage between P and Q as shown in figure. The measured voltage will be

- (a) 3.53 V
(b) 4.37 V
(c) 4.54 V
(d) 5.00 V

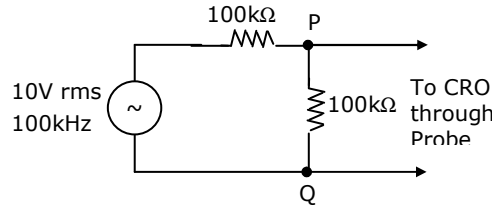

79. A moving coil of a meter has 100 turns, and a length and depth of 10 mm and 20 mm respectively. It is positioned in a uniform radial flux density of 200 mT. The coil carries a current of 50 mA. The torque on the coil is

- (a) $200\text{ }\mu\text{Nm}$ (b) $100\text{ }\mu\text{Nm}$ (c) $1000\text{ }\mu\text{Nm}$ (d) $1\text{ }\mu\text{Nm}$

80. A dc A-h meter is rated for 15 A, 250V. The meter constant is 14.4 A-sec/rev. The meter constant at rated voltage may be expressed as

- (a) 3750 rev/kWh (b) 3600 rev/kWh (c) 1000 rev/kWh (d) 960 rev/kWh

81. A moving iron ammeter produces a full-scale torque of $240\text{ }\mu\text{Nm}$ with a deflection of 120° at a current of 10 A. The rate of change of self inductance ($\mu\text{H}/\text{radian}$) of the instrument at full scale is

- (a) $2.0\text{ }\mu\text{H}/\text{radian}$ (b) $4.8\text{ }\mu\text{H}/\text{radian}$
(c) $12.0\text{ }\mu\text{H}/\text{radian}$ (d) $114.6\text{ }\mu\text{H}/\text{radian}$

82. A single-phase load is connected between R and Y terminals of a 415 V, symmetrical, 3-phase, 4-wire system with phase sequence RYB. A wattmeter is connected in the system as shown in figure. The power factor of the load is 0.8 lagging. The wattmeter will read

- (a) -795 W
(b) -597 W
(c) $+597\text{ W}$
(d) $+795\text{ W}$

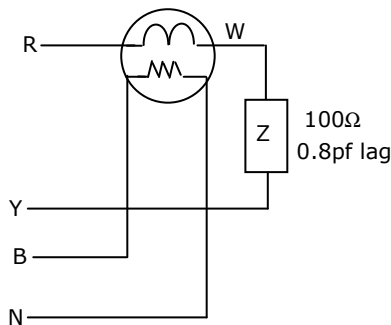

83. A 50 Hz, bar primary CT has a secondary with 500 turns. The secondary supplies 5A current into a purely resistive burden of 1Ω . The magnetizing ampere-turns is 200. The phase angle between the primary and secondary current is

- (a) 4.6° (b) 85.4° (c) 94.6° (d) 175.4°

84. The core flux in the CT of problem 83, under the given operating condition is
 (a) 0 (b) 45.0 μWb (c) 22.5 mWb (d) 100.0 mWb

85. A MOSFET rated for 15 A, carries a periodic current as shown in figure. The ON state resistance of the MOSFET is 0.15Ω . The average ON state loss in the MOSFET is
 (a) 33.8 W
 (b) 15.0 W
 (c) 7.5 W
 (d) 3.8 W

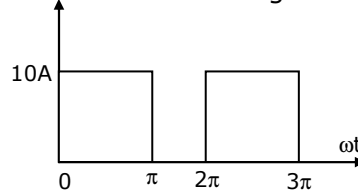

86. The triac circuit shown in figure controls the ac output power to the resistive load. The peak power dissipation in the load is
 (a) 3968 W
 (b) 5290 W
 (c) 7935 W
 (d) 10580 W

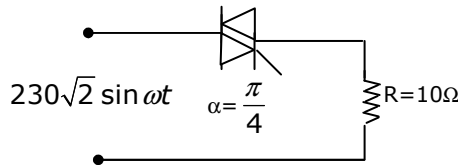

87. Figure shows a chopper operating from a 100 V dc input. The duty ratio of the main switch S is 0.8. The load is sufficiently inductive so that the load current is ripple free. The average current through the diode D under steady state is

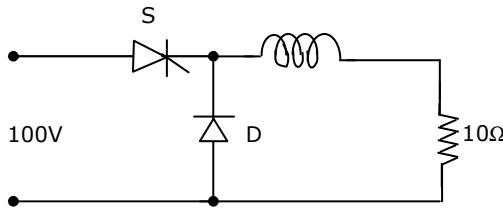

- (a) 1.6 A (b) 6.4 A (c) 8.0 A (d) 10.0 A
88. Figure shows a chopper. The device S1 is the main switching device. S2 is the auxiliary commutation device. S1 is rated for 400V, 60A. S2 is rated for 400V, 30 A. the load current is 20 A. The main device operates with a duty ratio of 0.5. The peak current through S1 is

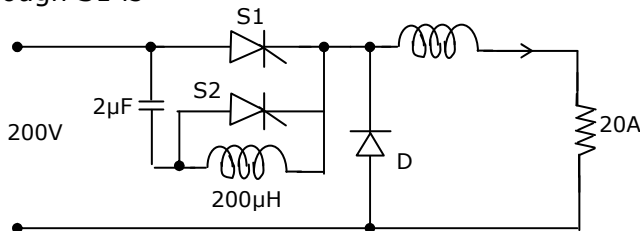

- (a) 10 A (b) 20 A (c) 30 A (d) 40 A

89. A single-phase half-controlled rectifier is driving a separately excited dc motor. The dc motor has a back emf constant of 0.5 V/rpm. The armature current is constant at 10 A without any ripple. The armature resistance is 2Ω . The converter is working from a 230 V, single-phase ac source with a firing angle of 30° . Under this operating condition, the speed of the motor will be
 (a) 339 rpm (b) 359 rpm (c) 366 rpm (d) 386 rpm
90. A variable speed drive rated for 1500 rpm, 40 Nm is reversing under no load. Figure shows the reversing torque and the speed during the transient. The moment of inertia of the drive is

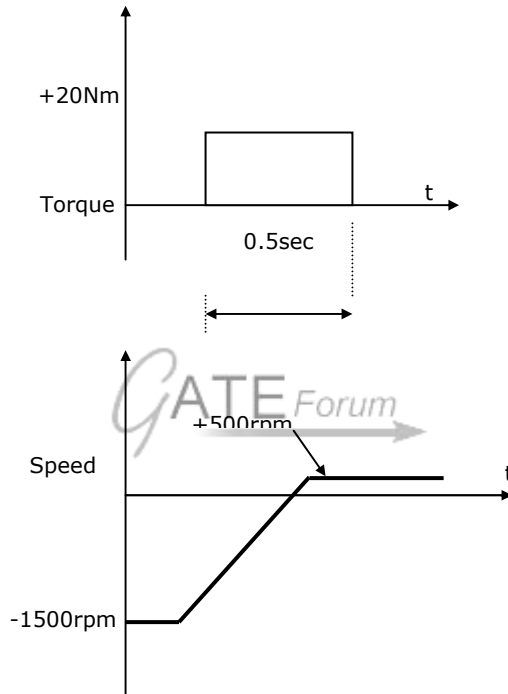

- (a) 0.048 kg m^2 (b) 0.064 kg m^2
 (c) 0.096 kg m^2 (d) 0.128 kg m^2