

2007

EC: Electronics and Communication Engineering

Duration : Three Hours

Maximum Marks :150

StudentBounty.com

Read the following instructions carefully.

1. This question paper contains 85 objective type questions. Q.1 to Q.20 carry **one** mark each and Q.21 to Q.85 carry **two** marks each.
2. Attempt all the questions.
3. Questions must be answered on **Objective Response Sheet (ORS)** by darkening the appropriate bubble (marked A, B, C, D) using HB pencil against the question number on the left hand side of the **ORS**. **Each question has only one correct answer**. In case you wish to change an answer, erase the old answer completely.
4. Wrong answers will carry **NEGATIVE** marks. In Q.1 to Q.20, **0.25** mark will be deducted for each wrong answer. In Q.21 to Q.76, Q.78, Q.80, Q.82 and in Q.84, **0.5** mark will be deducted for each wrong answer. However, there is no negative marking in Q.77, Q.79, Q.81, Q.83 and in Q.85. More than one answer bubbled against a question will be taken as an incorrect response. Unattempted questions will not carry any marks.
5. Write your registration number, your name and name of the examination centre at the specified locations on the right half of the **ORS**.
6. Using HB pencil, darken the appropriate bubble under each digit of your registration number and the letters corresponding to your paper code.
7. Calculator is allowed in the examination hall.
8. Charts, graph sheets or tables are **NOT** allowed in the examination hall.
9. Rough work can be done on the question paper itself. Additionally blank pages are given at the end of the question paper for rough work.
10. This question paper contains **28** printed pages including pages for rough work. Please check all pages and report, if there is any discrepancy.

Q. 1 – Q. 20 carry one mark each.

Q.1 If E denotes expectation, the variance of a random variable X is given by

- (A) $E[X^2] - E^2[X]$ (B) $E[X^2] + E^2[X]$
 (C) $E[X^2]$ (D) $E^2[X]$

Q.2 The following plot shows a function y which varies linearly with x . The value of the integral $I = \int_1^2 y \, dx$ is

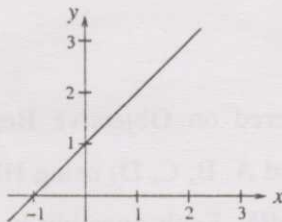

- (A) 1.0 (B) 2.5 (C) 4.0 (D) 5.0

Q.3 For $|x| \ll 1$, $\coth(x)$ can be approximated as

- (A) x (B) x^2 (C) $\frac{1}{x}$ (D) $\frac{1}{x^2}$

Q.4 $\lim_{\theta \rightarrow 0} \frac{\sin(\theta/2)}{\theta}$ is

- (A) 0.5 (B) 1 (C) 2 (D) not defined

Q.5 Which one of the following functions is strictly bounded?

- (A) $\frac{1}{x^2}$ (B) e^x (C) x^2 (D) e^{-x^2}

Q.6 For the function e^{-x} , the linear approximation around $x = 2$ is

- (A) $(3-x)e^{-2}$ (B) $1-x$
 (C) $[3 + 2\sqrt{2} - (1 + \sqrt{2})x]e^{-2}$ (D) e^{-2}

Q.7 An independent voltage source in series with an impedance $\mathbf{Z}_S = R_S + jX_S$ delivers a maximum average power to a load impedance \mathbf{Z}_L when

- (A) $\mathbf{Z}_L = R_S + jX_S$ (B) $\mathbf{Z}_L = R_S$
 (C) $\mathbf{Z}_L = jX_S$ (D) $\mathbf{Z}_L = R_S - jX_S$

Q.8 The RC circuit shown in the figure is

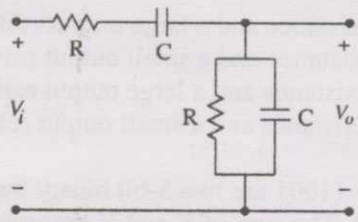

- (A) a low-pass filter (B) a high-pass filter
(C) a band-pass filter (D) a band-reject filter

Q.9 The electron and hole concentrations in an intrinsic semiconductor are n_i per cm^3 at 300 K. Now, if acceptor impurities are introduced with a concentration of N_A per cm^3 (where $N_A \gg n_i$), the electron concentration per cm^3 at 300 K will be

- (A) n_i (B) $n_i + N_A$ (C) $N_A - n_i$ (D) $\frac{n_i^2}{N_A}$

Q.10 In a p^+n junction diode under reverse bias, the magnitude of electric field is maximum at

- (A) the edge of the depletion region on the p -side
(B) the edge of the depletion region on the n -side
(C) the p^+n junction
(D) the centre of the depletion region on the n -side

Q.11 The correct full wave rectifier circuit is

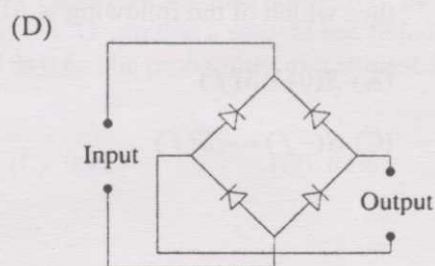
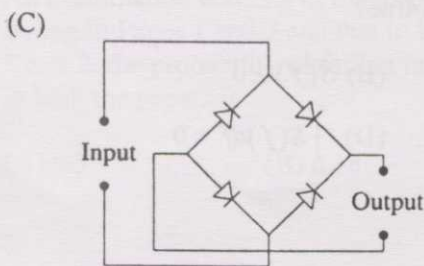
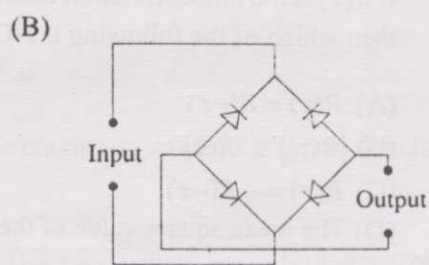
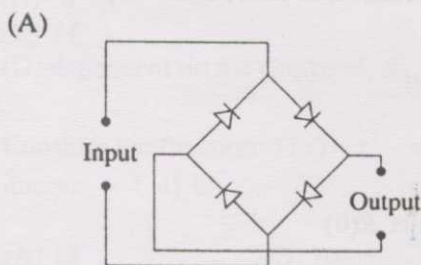

- Q.12 In a transconductance amplifier, it is desirable to have
- (A) a large input resistance and a large output resistance
 - (B) a large input resistance and a small output resistance
 - (C) a small input resistance and a large output resistance
 - (D) a small input resistance and a small output resistance
- Q.13 $X = 01110$ and $Y = 11001$ are two 5-bit binary numbers represented in two's complement format. The sum of X and Y represented in two's complement format using 6 bits is
- (A) 100111
 - (B) 001000
 - (C) 000111
 - (D) 101001
- Q.14 The Boolean function $Y = AB + CD$ is to be realized using only 2-input NAND gates. The minimum number of gates required is
- (A) 2
 - (B) 3
 - (C) 4
 - (D) 5
- Q.15 If the closed-loop transfer function of a control system is given as $T(s) = \frac{s-5}{(s+2)(s+3)}$, then it is
- (A) an unstable system
 - (B) an uncontrollable system
 - (C) a minimum phase system
 - (D) a non-minimum phase system
- Q.16 If the Laplace transform of a signal $y(t)$ is $Y(s) = \frac{1}{s(s-1)}$, then its final value is
- (A) -1
 - (B) 0
 - (C) 1
 - (D) Unbounded
- Q.17 If $R(\tau)$ is the autocorrelation function of a real, wide-sense stationary random process, then which of the following is NOT true?
- (A) $R(\tau) = R(-\tau)$
 - (B) $|R(\tau)| \leq R(0)$
 - (C) $R(\tau) = -R(-\tau)$
 - (D) The mean square value of the process is $R(0)$
- Q.18 If $S(f)$ is the power spectral density of a real, wide-sense stationary random process, then which of the following is ALWAYS true?
- (A) $S(0) \geq S(f)$
 - (B) $S(f) \geq 0$
 - (C) $S(-f) = -S(f)$
 - (D) $\int_{-\infty}^{\infty} S(f) df = 0$

- Q.19 A plane wave of wavelength λ is travelling in a direction making an angle 30° with the positive x -axis and 90° with positive y -axis. The \vec{E} field of the plane wave can be represented as (E_0 is a constant)

(A) $\vec{E} = \hat{y} E_0 e^{j\left(\omega t - \frac{\sqrt{3}\pi}{\lambda}x - \frac{\pi}{\lambda}z\right)}$ (B) $\vec{E} = \hat{y} E_0 e^{j\left(\omega t - \frac{\pi}{\lambda}x - \frac{\sqrt{3}\pi}{\lambda}z\right)}$
 (C) $\vec{E} = \hat{y} E_0 e^{j\left(\omega t + \frac{\sqrt{3}\pi}{\lambda}x + \frac{\pi}{\lambda}z\right)}$ (D) $\vec{E} = \hat{y} E_0 e^{j\left(\omega t - \frac{\pi}{\lambda}x + \frac{\sqrt{3}\pi}{\lambda}z\right)}$

- Q.20 If C is a closed curve enclosing a surface S , then the magnetic field intensity \vec{H} , the current density \vec{J} and the electric flux density \vec{D} are related by

(A) $\iint_S \vec{H} \cdot d\vec{s} = \oint_C \left(\vec{J} + \frac{\partial \vec{D}}{\partial t}\right) \cdot d\vec{l}$ (B) $\int_C \vec{H} \cdot d\vec{l} = \oiint_S \left(\vec{J} + \frac{\partial \vec{D}}{\partial t}\right) \cdot d\vec{s}$
 (C) $\oiint_S \vec{H} \cdot d\vec{s} = \int_C \left(\vec{J} + \frac{\partial \vec{D}}{\partial t}\right) \cdot d\vec{l}$ (D) $\oint_C \vec{H} \cdot d\vec{l} = \iint_S \left(\vec{J} + \frac{\partial \vec{D}}{\partial t}\right) \cdot d\vec{s}$

Q. 21 to Q. 75 carry two marks each.

- Q.21 It is given that X_1, X_2, \dots, X_M are M non-zero, orthogonal vectors. The dimension of the vector space spanned by the $2M$ vectors $X_1, X_2, \dots, X_M, -X_1, -X_2, \dots, -X_M$ is

- (A) $2M$
 (B) $M+1$
 (C) M
 (D) dependent on the choice of X_1, X_2, \dots, X_M

- Q.22 Consider the function $f(x) = x^2 - x - 2$. The maximum value of $f(x)$ in the closed interval $[-4, 4]$ is

- (A) 18 (B) 10 (C) -2.25 (D) indeterminate

- Q.23 An examination consists of two papers, Paper 1 and Paper 2. The probability of failing in Paper 1 is 0.3 and that in Paper 2 is 0.2. Given that a student has failed in Paper 2, the probability of failing in Paper 1 is 0.6. The probability of a student failing in both the papers is

- (A) 0.5 (B) 0.18 (C) 0.12 (D) 0.06

Q.24 The solution of the differential equation $k^2 \frac{d^2 y}{dx^2} = y - y_2$ under the boundary conditions (i) $y = y_1$ at $x = 0$ and (ii) $y = y_2$ at $x = \infty$, where k , y_1 and y_2 are constants, is

- (A) $y = (y_1 - y_2) \exp(-x/k^2) + y_2$ (B) $y = (y_2 - y_1) \exp(-x/k) + y_1$
 (C) $y = (y_1 - y_2) \sinh(x/k) + y_1$ (D) $y = (y_1 - y_2) \exp(-x/k) + y_2$

Q.25 The equation $x^3 - x^2 + 4x - 4 = 0$ is to be solved using the Newton-Raphson method. If $x = 2$ is taken as the initial approximation of the solution, then the next approximation using this method will be

- (A) $\frac{2}{3}$ (B) $\frac{4}{3}$ (C) 1 (D) $\frac{3}{2}$

Q.26 Three functions $f_1(t)$, $f_2(t)$ and $f_3(t)$, which are zero outside the interval $[0, T]$, are shown in the figure. Which of the following statements is correct?

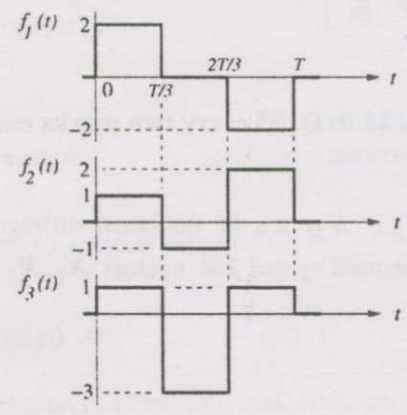

- (A) $f_1(t)$ and $f_2(t)$ are orthogonal
 (B) $f_1(t)$ and $f_3(t)$ are orthogonal
 (C) $f_2(t)$ and $f_3(t)$ are orthogonal
 (D) $f_1(t)$ and $f_2(t)$ are orthonormal

Q.27 If the semi-circular contour D of radius 2 is as shown in the figure, then the value of the integral $\oint_D \frac{1}{(s^2 - 1)} ds$ is

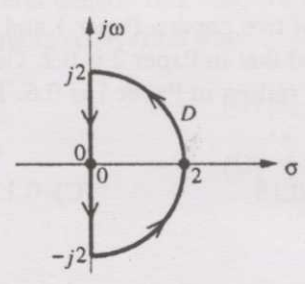

- (A) $j\pi$ (B) $-j\pi$ (C) $-\pi$ (D) π

- Q.28 Two series resonant filters are as shown in the figure. Let the 3-dB bandwidth of Filter 1 be B_1 and that of Filter 2 be B_2 . The value of $\frac{B_1}{B_2}$ is

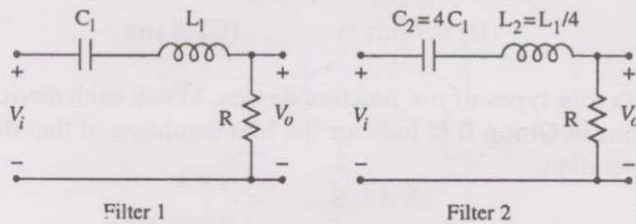

- (A) 4 (B) 1 (C) $\frac{1}{2}$ (D) $\frac{1}{4}$
- Q.29 For the circuit shown in the figure, the Thevenin voltage and resistance looking into X-Y are

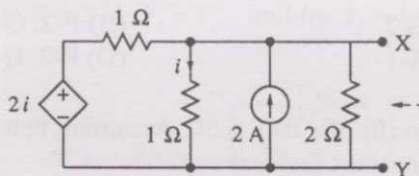

- (A) $\frac{4}{3}$ V, 2Ω (B) 4 V, $\frac{2}{3} \Omega$ (C) $\frac{4}{3}$ V, $\frac{2}{3} \Omega$ (D) 4 V, 2Ω
- Q.30 In the circuit shown, V_C is 0 volts at $t = 0$ sec. For $t > 0$, the capacitor current $i_c(t)$, where t is in seconds, is given by

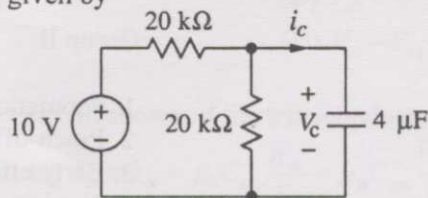

- (A) $0.50 \exp(-25t)$ mA (B) $0.25 \exp(-25t)$ mA
 (C) $0.50 \exp(-12.5t)$ mA (D) $0.25 \exp(-6.25t)$ mA
- Q.31 In the AC network shown in the figure, the phasor voltage V_{AB} (in Volts) is

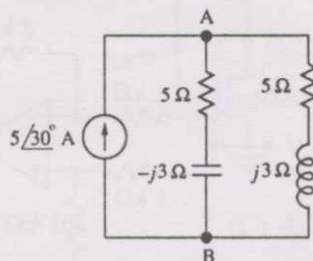

- (A) 0 (B) $5 \angle 30^\circ$ (C) $12.5 \angle 30^\circ$ (D) $17 \angle 30^\circ$

Q.32 A p^+n junction has a built-in potential of 0.8 V. The depletion layer width at reverse bias of 1.2 V is $2 \mu\text{m}$. For a reverse bias of 7.2 V, the depletion layer width will be

- (A) $4 \mu\text{m}$ (B) $4.9 \mu\text{m}$ (C) $8 \mu\text{m}$ (D) $12 \mu\text{m}$

Q.33 Group I lists four types of $p-n$ junction diodes. Match each device in Group I with one of the options in Group II to indicate the bias condition of that device in its normal mode of operation.

Group I

- P. Zener Diode
 Q. Solar cell
 R. LASER diode
 S. Avalanche Photodiode

Group II

1. Forward bias
 2. Reverse bias

- (A) P-1, Q-2, R-1, S-2 (B) P-2, Q-1, R-1, S-2
 (C) P-2, Q-2, R-1, S-1 (D) P-2, Q-1, R-2, S-2

Q.34 The DC current gain (β) of a BJT is 50. Assuming that the emitter injection efficiency is 0.995, the base transport factor is

- (A) 0.980 (B) 0.985 (C) 0.990 (D) 0.995

Q.35 Group I lists four different semiconductor devices. Match each device in Group I with its characteristic property in Group II.

Group I

- P. BJT
 Q. MOS capacitor
 R. LASER diode
 S. JFET

Group II

1. Population inversion
 2. Pinch-off voltage
 3. Early effect
 4. Flat-band voltage

- (A) P-3, Q-1, R-4, S-2 (B) P-1, Q-4, R-3, S-2
 (C) P-3, Q-4, R-1, S-2 (D) P-3, Q-2, R-1, S-4

Q.36 For the Op-Amp circuit shown in the figure, V_o is

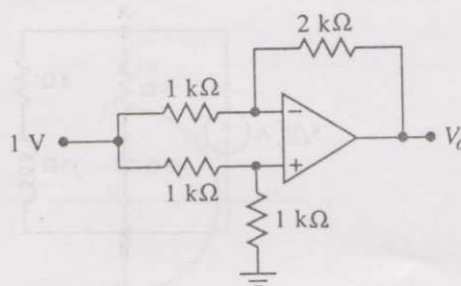

- (A) -2 V (B) -1 V (C) -0.5 V (D) 0.5 V

Q.37 For the BJT circuit shown, assume that the β of the transistor is very large and $V_{BE} = 0.7$ V. The mode of operation of the BJT is

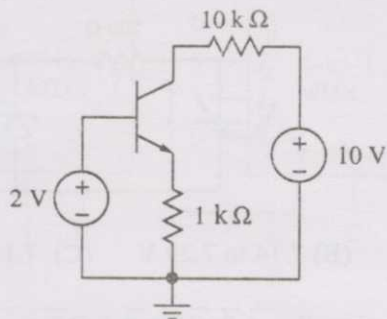

- (A) cut-off (B) saturation (C) normal active (D) reverse active

Q.38 In the Op-Amp circuit shown, assume that the diode current follows the equation $I = I_s \exp(V/V_T)$. For $V_i = 2$ V, $V_o = V_{o1}$, and for $V_i = 4$ V, $V_o = V_{o2}$. The relationship between V_{o1} and V_{o2} is

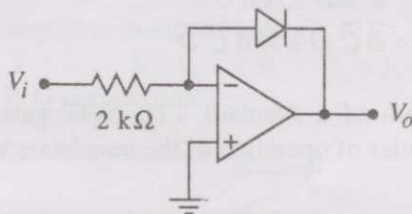

- (A) $V_{o2} = \sqrt{2} V_{o1}$ (B) $V_{o2} = e^2 V_{o1}$
 (C) $V_{o2} = V_{o1} \ln 2$ (D) $V_{o1} - V_{o2} = V_T \ln 2$

Q.39 In the CMOS inverter circuit shown, if the transconductance parameters of the NMOS and PMOS transistors are $k_n = k_p = \mu_n C_{ox} \frac{W_n}{L_n} = \mu_p C_{ox} \frac{W_p}{L_p} = 40 \mu\text{A}/\text{V}^2$ and their threshold voltages are $V_{THn} = |V_{THp}| = 1$ V, the current I is

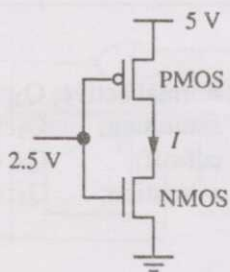

- (A) 0 A (B) 25 μA (C) 45 μA (D) 90 μA

Q.40 For the Zener diode shown in the figure, the Zener voltage at knee is 7 V, the current is negligible and the Zener dynamic resistance is 10 Ω. If the input voltage (V_i) range is from 10 to 16 V, the output voltage (V_o) ranges from

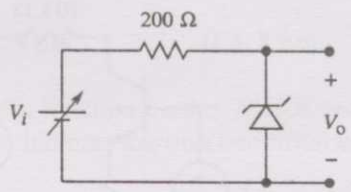

- (A) 7.00 to 7.29 V (B) 7.14 to 7.29 V (C) 7.14 to 7.43 V (D) 7.29 to 7.43 V

Q.41 The Boolean expression $Y = \bar{A}\bar{B}\bar{C}D + \bar{A}BC\bar{D} + A\bar{B}\bar{C}D + ABC\bar{D}$ can be minimized to

- (A) $Y = \bar{A}\bar{B}\bar{C}D + \bar{A}B\bar{C} + A\bar{C}D$
 (B) $Y = \bar{A}\bar{B}\bar{C}D + BC\bar{D} + A\bar{B}\bar{C}D$
 (C) $Y = \bar{A}BC\bar{D} + \bar{B}\bar{C}D + A\bar{B}\bar{C}D$
 (D) $Y = \bar{A}BC\bar{D} + \bar{B}\bar{C}D + ABC\bar{D}$

Q.42 The circuit diagram of a standard TTL NOT gate is shown in the figure. When $V_i = 2.5$ V, the modes of operation of the transistors will be

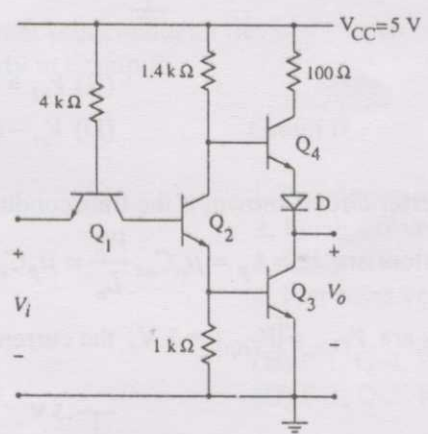

- (A) Q₁: reverse active; Q₂: normal active; Q₃: saturation; Q₄: cut-off
 (B) Q₁: reverse active; Q₂: saturation; Q₃: saturation; Q₄: cut-off
 (C) Q₁: normal active; Q₂: cut-off; Q₃: cut-off; Q₄: saturation
 (D) Q₁: saturation; Q₂: saturation; Q₃: saturation; Q₄: normal active

Q.43 In the following circuit, X is given by

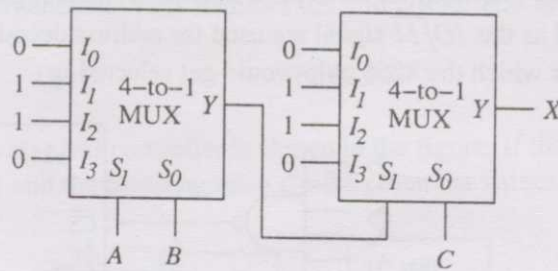

- (A) $X = A\bar{B}\bar{C} + \bar{A}B\bar{C} + \bar{A}\bar{B}C + ABC$
- (B) $X = \bar{A}BC + A\bar{B}C + ABC + \bar{A}\bar{B}\bar{C}$
- (C) $X = AB + BC + AC$
- (D) $X = \bar{A}\bar{B} + \bar{B}\bar{C} + \bar{A}\bar{C}$

Q.44 The following binary values were applied to the X and Y inputs of the NAND latch shown in the figure in the sequence indicated below:

$X = 0, Y = 1; \quad X = 0, Y = 0; \quad X = 1, Y = 1.$

The corresponding stable P, Q outputs will be

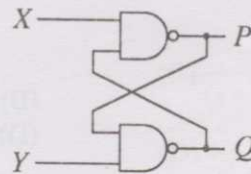

- | | | |
|---------------------|-----------------------------------|----------------------------------|
| (A) $P = 1, Q = 0;$ | $P = 1, Q = 0;$ | $P = 1, Q = 0$ or $P = 0, Q = 1$ |
| (B) $P = 1, Q = 0;$ | $P = 0, Q = 1$ or $P = 0, Q = 1;$ | $P = 0, Q = 1$ |
| (C) $P = 1, Q = 0;$ | $P = 1, Q = 1;$ | $P = 1, Q = 0$ or $P = 0, Q = 1$ |
| (D) $P = 1, Q = 0;$ | $P = 1, Q = 1;$ | $P = 1, Q = 1$ |

Q.45 For the circuit shown, the counter state (Q_1Q_0) follows the sequence

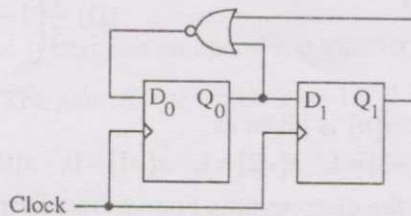

- | | |
|----------------------------|----------------------------|
| (A) 00, 01, 10, 11, 00 ... | (B) 00, 01, 10, 00, 01 ... |
| (C) 00, 01, 11, 00, 01 ... | (D) 00, 10, 11, 00, 10 ... |

- Q.46 An 8255 chip is interfaced to an 8085 microprocessor system as an I/O mapping shown in the figure. The address lines A_0 and A_1 of the 8085 are used by the 8255 chip to decode internally its three ports and the Control register. The address lines A_2 to A_7 as well as the IO/\overline{M} signal are used for address decoding. The range of addresses for which the 8255 chip would get selected is

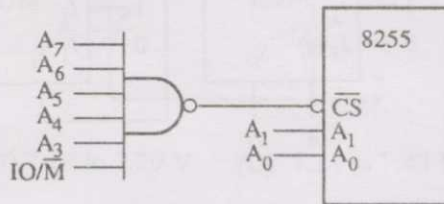

- (A) F8H – FBH
(B) F8H – FCH
(C) F8H – FFH
(D) F0H – F7H
- Q.47 The 3-dB bandwidth of the low-pass signal $e^{-t}u(t)$, where $u(t)$ is the unit step function, is given by

- (A) $\frac{1}{2\pi}$ Hz
(B) $\frac{1}{2\pi}\sqrt{\sqrt{2}-1}$ Hz
(C) ∞
(D) 1 Hz

- Q.48 A Hilbert transformer is a

- (A) non-linear system
(B) non-causal system
(C) time-varying system
(D) low-pass system

- Q.49 The frequency response of a linear, time-invariant system is given by

$$H(f) = \frac{5}{1 + j10\pi f}. \text{ The step response of the system is}$$

- (A) $5(1 - e^{-5t})u(t)$
(B) $5\left(1 - e^{-\frac{t}{5}}\right)u(t)$
(C) $\frac{1}{5}(1 - e^{-5t})u(t)$
(D) $\frac{1}{5}\left(1 - e^{-\frac{t}{5}}\right)u(t)$

- Q.50 A 5-point sequence $x[n]$ is given as

$$x[-3]=1, x[-2]=1, x[-1]=0, x[0]=5, x[1]=1.$$

Let $X(e^{j\omega})$ denote the discrete-time Fourier transform of $x[n]$. The value of

$$\int_{-\pi}^{\pi} X(e^{j\omega}) d\omega \text{ is}$$

- (A) 5
(B) 10π
(C) 16π
(D) $5 + j10\pi$

Q.51 The z-transform $X[z]$ of a sequence $x[n]$ is given by $X[z] = \frac{0.5}{1-2z^{-1}}$. It is given that the region of convergence of $X[z]$ includes the unit circle. The value of $x[0]$ is

- (A) -0.5 (B) 0 (C) 0.25 (D) 0.5

Q.52 A control system with a PD controller is shown in the figure. If the velocity error constant $K_v = 1000$ and the damping ratio $\zeta = 0.5$, then the values of K_p and K_D are

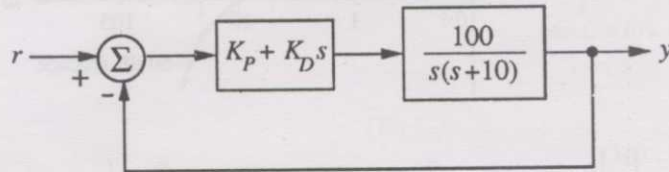

- (A) $K_p = 100, K_D = 0.09$ (B) $K_p = 100, K_D = 0.9$
 (C) $K_p = 10, K_D = 0.09$ (D) $K_p = 10, K_D = 0.9$

Q.53 The transfer function of a plant is $T(s) = \frac{5}{(s+5)(s^2+s+1)}$. The second-order approximation of $T(s)$ using dominant pole concept is

- (A) $\frac{1}{(s+5)(s+1)}$ (B) $\frac{5}{(s+5)(s+1)}$
 (C) $\frac{5}{s^2+s+1}$ (D) $\frac{1}{s^2+s+1}$

Q.54 The open-loop transfer function of a plant is given as $G(s) = \frac{1}{s^2-1}$. If the plant is operated in a unity feedback configuration, then the lead compensator that can stabilize this control system is

- (A) $\frac{10(s-1)}{s+2}$ (B) $\frac{10(s+4)}{s+2}$ (C) $\frac{10(s+2)}{s+10}$ (D) $\frac{2(s+2)}{s+10}$

Q.55 A unity feedback control system has an open-loop transfer function $G(s) = \frac{K}{s(s^2+7s+12)}$. The gain K for which $s = -1 + j1$ will lie on the root locus of this system is

- (A) 4 (B) 5.5 (C) 6.5 (D) 10

Q.56 The asymptotic Bode plot of a transfer function is as shown in the figure. The function $G(s)$ corresponding to this Bode plot is

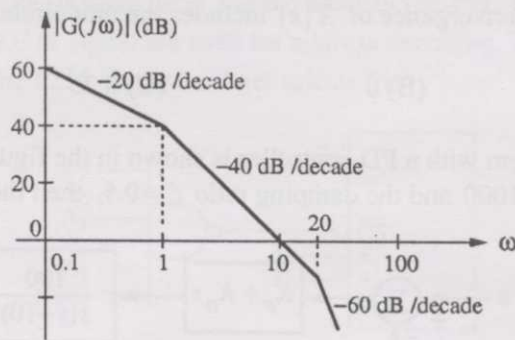

- (A) $\frac{1}{(s+1)(s+20)}$ (B) $\frac{1}{s(s+1)(s+20)}$
 (C) $\frac{100}{s(s+1)(s+20)}$ (D) $\frac{100}{s(s+1)(1+0.05s)}$

Q.57 The state space representation of a separately excited DC servo motor dynamics is given as

$$\begin{bmatrix} \frac{d\omega}{dt} \\ \frac{di_a}{dt} \end{bmatrix} = \begin{bmatrix} -1 & 1 \\ -1 & -10 \end{bmatrix} \begin{bmatrix} \omega \\ i_a \end{bmatrix} + \begin{bmatrix} 0 \\ 10 \end{bmatrix} u$$

where ω is the speed of the motor, i_a is the armature current and u is the armature voltage. The transfer function $\frac{\omega(s)}{U(s)}$ of the motor is

- (A) $\frac{10}{s^2 + 11s + 11}$ (B) $\frac{1}{s^2 + 11s + 11}$ (C) $\frac{10s + 10}{s^2 + 11s + 11}$ (D) $\frac{1}{s^2 + s + 1}$

Q.58 In delta modulation, the slope overload distortion can be reduced by

- (A) decreasing the step size (B) decreasing the granular noise
 (C) decreasing the sampling rate (D) increasing the step size

Q.59 The raised cosine pulse $p(t)$ is used for zero ISI in digital communications. The expression for $p(t)$ with unity roll-off factor is given by $p(t) = \frac{\sin 4\pi Wt}{4\pi Wt(1-16W^2t^2)}$.

The value of $p(t)$ at $t = \frac{1}{4W}$ is

- (A) -0.5 (B) 0 (C) 0.5 (D) ∞

Q.60 In the following scheme, if the spectrum $M(f)$ of $m(t)$ is as shown, then the spectrum $Y(f)$ of $y(t)$ will be

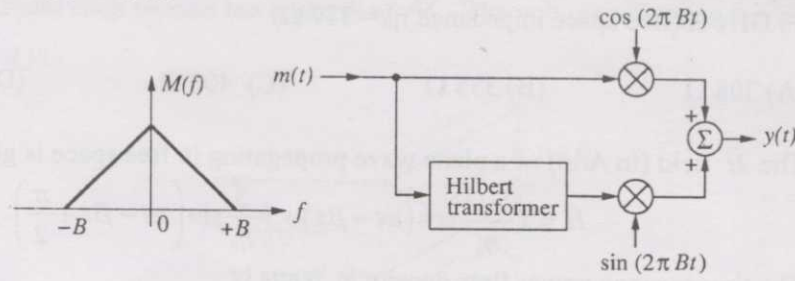

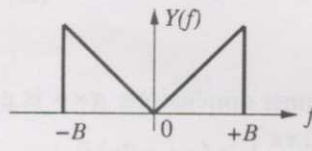
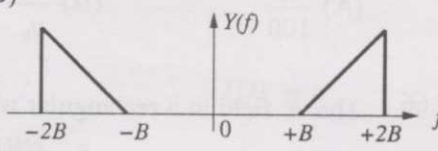
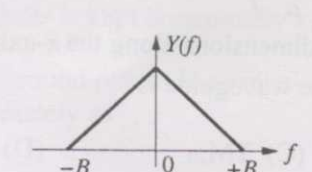
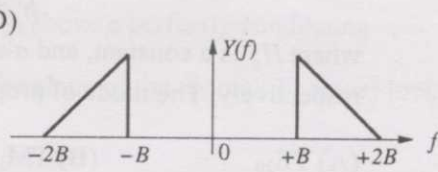
- (A) 
- (B) 
- (C) 
- (D) 

Q.61 During transmission over a certain binary communication channel, bit errors occur independently with probability p . The probability of AT MOST one bit in error in a block of n bits is given by

- (A) p^n (B) $1 - p^n$
 (C) $np(1-p)^{n-1} + (1-p)^n$ (D) $1 - (1-p)^n$

Q.62 In a GSM system, 8 channels can co-exist in 200 kHz bandwidth using TDMA. A GSM based cellular operator is allocated 5 MHz bandwidth. Assuming a frequency reuse factor of $\frac{1}{5}$, i.e. a five-cell repeat pattern, the maximum number of simultaneous channels that can exist in one cell is

- (A) 200 (B) 40 (C) 25 (D) 5

Q.63 In a Direct Sequence CDMA system the chip rate is 1.2288×10^6 chips per second. If the processing gain is desired to be AT LEAST 100, the data rate

- (A) must be less than or equal to 12.288×10^3 bits per sec
 (B) must be greater than 12.288×10^3 bits per sec
 (C) must be exactly equal to 12.288×10^3 bits per sec
 (D) can take any value less than 122.88×10^3 bits per sec

Q.64 An air-filled rectangular waveguide has inner dimensions of $3\text{ cm} \times 2\text{ cm}$. The impedance of the TE_{20} mode of propagation in the waveguide at a frequency of 30 GHz is (free space impedance $\eta_0 = 377\ \Omega$)

- (A) $308\ \Omega$ (B) $355\ \Omega$ (C) $400\ \Omega$ (D) $461\ \Omega$

Q.65 The \vec{H} field (in A/m) of a plane wave propagating in free space is given by

$$\vec{H} = \hat{x} \frac{5\sqrt{3}}{\eta_0} \cos(\omega t - \beta z) + \hat{y} \frac{5}{\eta_0} \sin\left(\omega t - \beta z + \frac{\pi}{2}\right).$$

The time average power flow density in Watts is

- (A) $\frac{\eta_0}{100}$ (B) $\frac{100}{\eta_0}$ (C) $50\eta_0^2$ (D) $\frac{50}{\eta_0}$

Q.66 The \vec{E} field in a rectangular waveguide of inner dimensions $a \times b$ is given by

$$\vec{E} = \frac{\omega\mu}{h^2} \left(\frac{\pi}{a}\right) H_0 \sin\left(\frac{2\pi x}{a}\right) \sin(\omega t - \beta z) \hat{y}$$

where H_0 is a constant, and a and b are the dimensions along the x -axis and the y -axis respectively. The mode of propagation in the waveguide is

- (A) TE_{20} (B) TM_{11} (C) TM_{20} (D) TE_{10}

Q.67 A load of $50\ \Omega$ is connected in shunt in a 2-wire transmission line of $Z_0 = 50\ \Omega$ as shown in the figure. The 2-port scattering parameter matrix (S-matrix) of the shunt element is

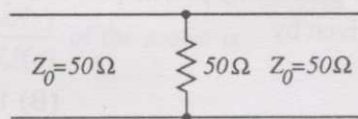

(A) $\begin{bmatrix} -\frac{1}{2} & \frac{1}{2} \\ \frac{1}{2} & -\frac{1}{2} \end{bmatrix}$

(B) $\begin{bmatrix} 0 & 1 \\ 1 & 0 \end{bmatrix}$

(C) $\begin{bmatrix} -\frac{1}{3} & \frac{2}{3} \\ \frac{2}{3} & -\frac{1}{3} \end{bmatrix}$

(D) $\begin{bmatrix} \frac{1}{4} & -\frac{3}{4} \\ -\frac{3}{4} & \frac{1}{4} \end{bmatrix}$

- Q.68 The parallel branches of a 2-wire transmission line are terminated in $100\ \Omega$ and $200\ \Omega$ resistors as shown in the figure. The characteristic impedance of the line is $Z_0 = 50\ \Omega$ and each section has a length of $\lambda/4$. The voltage reflection coefficient Γ at the input is

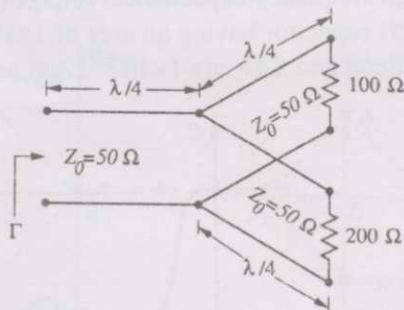

- (A) $-j\frac{7}{5}$ (B) $-\frac{5}{7}$ (C) $j\frac{5}{7}$ (D) $\frac{5}{7}$
- Q.69 A $\frac{\lambda}{2}$ dipole is kept horizontally at a height of $\frac{\lambda_0}{2}$ above a perfectly conducting infinite ground plane. The radiation pattern in the plane of the dipole (\vec{E} plane) looks approximately as

(A)

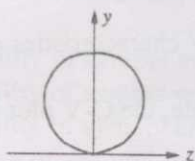

(B)

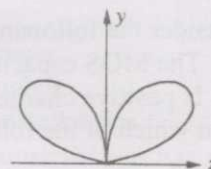

(C)

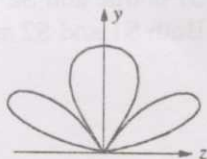

(D)

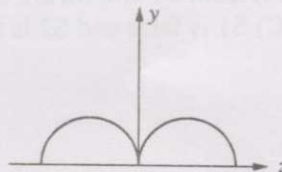

- Q.70 A right circularly polarized (RCP) plane wave is incident at an angle of 60° to the normal, on an air-dielectric interface. If the reflected wave is linearly polarized, the relative dielectric constant ϵ_{r2} is

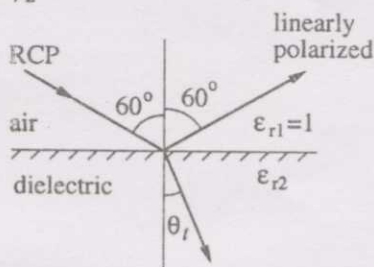

(A) $\sqrt{2}$

(B) $\sqrt{3}$

(C) 2

(D) 3

Common Data Questions

Common Data for Questions 71,72,73:

The figure shows the high-frequency capacitance-voltage (C-V) characteristics of a Metal/SiO₂/silicon (MOS) capacitor having an area of $1 \times 10^{-4} \text{ cm}^2$. Assume that the permittivities ($\epsilon_0\epsilon_r$) of silicon and SiO₂ are $1 \times 10^{-12} \text{ F/cm}$ and $3.5 \times 10^{-13} \text{ F/cm}$ respectively.

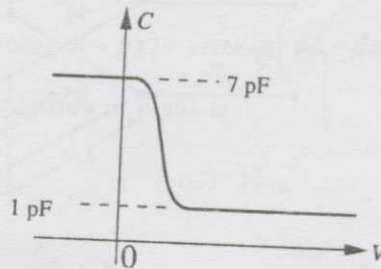

- Q.71 The gate oxide thickness in the MOS capacitor is
 (A) 50 nm (B) 143 nm (C) 350 nm (D) 1 μm
- Q.72 The maximum depletion layer width in silicon is
 (A) 0.143 μm (B) 0.857 μm (C) 1 μm (D) 1.143 μm
- Q.73 Consider the following statements about the C-V characteristics plot:
 S1: The MOS capacitor has an *n*-type substrate.
 S2: If positive charges are introduced in the oxide, the C-V plot will shift to the left.
 Then which of the following is true?
 (A) Both S1 and S2 are true (B) S1 is true and S2 is false
 (C) S1 is false and S2 is true (D) Both S1 and S2 are false

Common Data for Questions 74, 75:

Two 4-ary signal constellations are shown. It is given that ϕ_1 and ϕ_2 constitute an orthonormal basis for the two constellations. Assume that the four symbols in both the constellations are equiprobable. Let $\frac{N_0}{2}$ denote the power spectral density of white Gaussian noise.

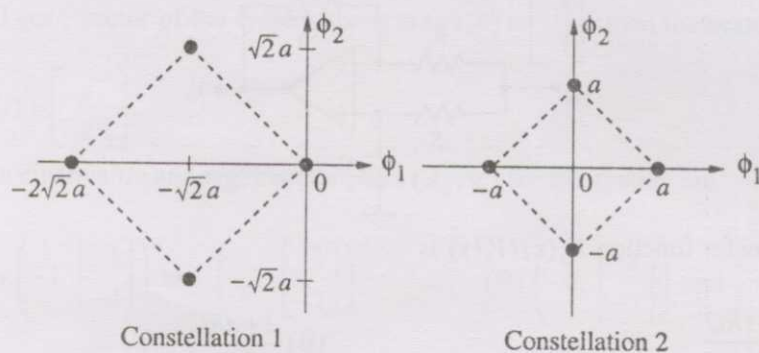

- Q.74 The ratio of the average energy of Constellation 1 to the average energy of Constellation 2 is
- (A) $4a^2$ (B) 4 (C) 2 (D) 8
- Q.75 If these constellations are used for digital communications over an AWGN channel, then which of the following statements is true?
- (A) Probability of symbol error for Constellation 1 is lower
 (B) Probability of symbol error for Constellation 1 is higher
 (C) Probability of symbol error is equal for both the constellations
 (D) The value of N_0 will determine which of the two constellations has a lower probability of symbol error

Linked Answer Questions: Q.76 to Q.85 carry two marks each.

Statement for Linked Answer Questions 76 & 77:

Consider the Op-Amp circuit shown in the figure.

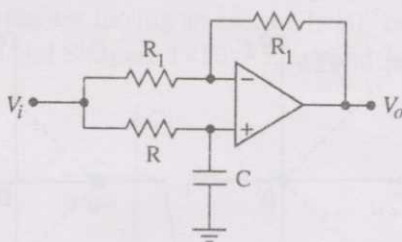

Q.76 The transfer function $V_o(s)/V_i(s)$ is

(A) $\frac{1-sRC}{1+sRC}$

(B) $\frac{1+sRC}{1-sRC}$

(C) $\frac{1}{1-sRC}$

(D) $\frac{1}{1+sRC}$

Q.77 If $V_i = V_1 \sin(\omega t)$ and $V_o = V_2 \sin(\omega t + \phi)$, then the minimum and maximum values of ϕ (in radians) are respectively

(A) $-\pi/2$ and $\pi/2$

(B) 0 and $\pi/2$

(C) $-\pi$ and 0

(D) $-\pi/2$ and 0

Statement for Linked Answer Questions 78 & 79:

An 8085 assembly language program is given below.

```
Line 1: MVI A,B5H
2: MVI B,0EH
3: XRI 69H
4: ADD B
5: ANI 9BH
6: CPI 9FH
7: STA 3010H
8: HLT
```

Q.78 The contents of the accumulator just after execution of the ADD instruction in line 4 will be

(A) C3H

(B) EAH

(C) DCH

(D) 69H

Q.79 After execution of line 7 of the program, the status of the CY and Z flags will be

(A) CY = 0, Z = 0

(B) CY = 0, Z = 1

(C) CY = 1, Z = 0

(D) CY = 1, Z = 1

Statement for Linked Answer Questions 80 & 81:

Consider a linear system whose state space representation is $\dot{x}(t) = Ax(t)$. If the initial state

vector of the system is $x(0) = \begin{bmatrix} 1 \\ -2 \end{bmatrix}$, then the system response is $x(t) = \begin{bmatrix} e^{-2t} \\ -2e^{-2t} \end{bmatrix}$

If the initial state vector of the system changes to $x(0) = \begin{bmatrix} 1 \\ -1 \end{bmatrix}$, then the system response

becomes $x(t) = \begin{bmatrix} e^{-t} \\ -e^{-t} \end{bmatrix}$.

Q.80 The eigenvalue and eigenvector pairs (λ, v_i) for the system are

(A) $\left(-1, \begin{bmatrix} 1 \\ -1 \end{bmatrix}\right)$ and $\left(-2, \begin{bmatrix} 1 \\ -2 \end{bmatrix}\right)$ (B) $\left(-2, \begin{bmatrix} 1 \\ -1 \end{bmatrix}\right)$ and $\left(-1, \begin{bmatrix} 1 \\ -2 \end{bmatrix}\right)$

(C) $\left(-1, \begin{bmatrix} 1 \\ -1 \end{bmatrix}\right)$ and $\left(2, \begin{bmatrix} 1 \\ -2 \end{bmatrix}\right)$ (D) $\left(-2, \begin{bmatrix} 1 \\ -1 \end{bmatrix}\right)$ and $\left(1, \begin{bmatrix} 1 \\ -2 \end{bmatrix}\right)$

Q.81 The system matrix **A** is

(A) $\begin{bmatrix} 0 & 1 \\ -1 & 1 \end{bmatrix}$ (B) $\begin{bmatrix} 1 & 1 \\ -1 & -2 \end{bmatrix}$ (C) $\begin{bmatrix} 2 & 1 \\ -1 & -1 \end{bmatrix}$ (D) $\begin{bmatrix} 0 & 1 \\ -2 & -3 \end{bmatrix}$

Statement for Linked Answer Questions 82 & 83:

An input to a 6-level quantizer has the probability density function $f(x)$ as shown in the figure. Decision boundaries of the quantizer are chosen so as to maximize the entropy of the quantizer output. It is given that 3 consecutive decision boundaries are '-1', '0' and '1'.

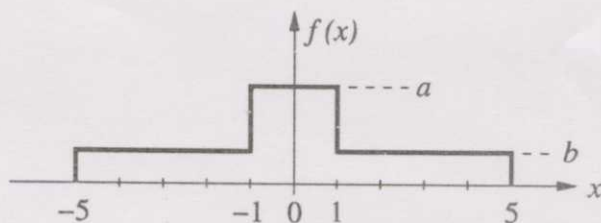

Q.82 The values of a and b are

(A) $a = 1/6$ and $b = 1/12$ (B) $a = 1/5$ and $b = 3/40$
 (C) $a = 1/4$ and $b = 1/16$ (D) $a = 1/3$ and $b = 1/24$

Q.83 Assuming that the reconstruction levels of the quantizer are the mid-points of the decision boundaries, the ratio of signal power to quantization noise power is

(A) $\frac{152}{9}$ (B) $\frac{64}{3}$ (C) $\frac{76}{3}$ (D) 28

Statement for Linked Answer Questions 84 & 85:

In the Digital-to-Analog converter circuit shown in the figure below, $V_R = 10\text{ V}$ and $R = 10\text{ k}\Omega$.

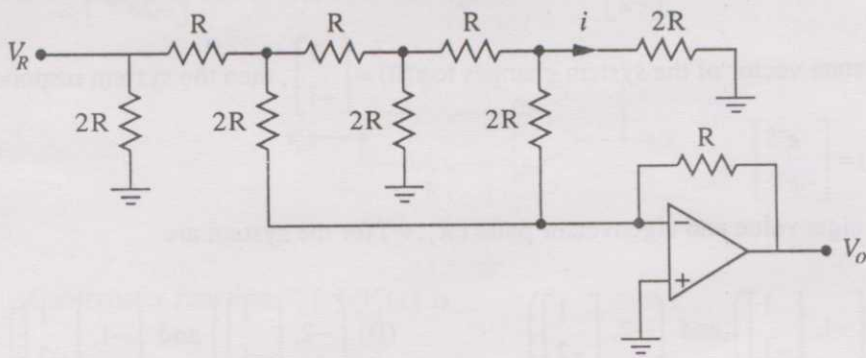

Q.84 The current i is

- (A) $31.25\ \mu\text{A}$ (B) $62.5\ \mu\text{A}$ (C) $125\ \mu\text{A}$ (D) $250\ \mu\text{A}$

Q.85 The voltage V_o is

- (A) -0.781 V (B) -1.562 V (C) -3.125 V (D) -6.250 V

END OF THE QUESTION PAPER