

EUROPEAN QUALIFYING EXAMINATION 2014

Paper C

This paper comprises:

- | | |
|--|-----------------|
| * Letter from opponent to professional representative | 2014/C/EN/1-2 |
| * Annex 1 | 2014/C/EN/3-11 |
| * Annex 2 | 2014/C/EN/12-14 |
| * Annex 3 | 2014/C/EN/15-18 |
| * Annex 4 | 2014/C/EN/19-21 |
| * Annex 5 | 2014/C/EN/22-24 |
| * Annex 6 | 2014/C/EN/25-29 |
| * Form 2300: Notice of opposition to a European patent | |

Ms Sylvia Skinner
Babysoft Co. Ltd.
Velvet Bottom, Somerset
BA5 2TD
ENGLAND

Mr Stoppelkin
European Patent Attorney
Kratzgasse 1
2500 Baden
AUSTRIA

Velvet Bottom, 01.02.2014

Dear Mr Stoppelkin,

We would like you to file an opposition on behalf of Babysoft Co. Ltd. against European Patent EP 3 023 023 B1 (Annex 1) granted to Closeshave Co. Ltd.

We have found some documents (Annexes 2 to 6) which might be of use to you.

We have noticed that Annex 1 claims priority from application GB344566. Annex 1 as filed on 07.01.2011 is identical to the text of GB344566 apart from the feature of claim 3 that the resilient foam material may be a biodegradable starch copolymer and corresponding paragraph [0013], which were both added at the date of filing of Annex 1.

Further, claim 2 was added during the examination of the application. The description was not amended during the examination.



Annex 6 (from Closeshave Co. Ltd.) claims priority from AU PR 4343. Annex 6 is identical to AU PR 4343 except that the features mentioned in paragraphs [0007], [0008] and [0011] were first introduced on the filing of Annex 6.

Yours sincerely,
Sylvia Skinner

Enclosures:

- Annex 1: EP 3 023 023
- Annex 2: EP 1 114 141
- Annex 3: US 2002/0025883
- Annex 4: CA 2 020 300
- Annex 5: DE 101 40 330
- Annex 6: AU 2010454545



(19)  **Europäisches Patentamt**
European Patent Office
Office européen des brevets

(11) **EP 3 023 023**(12) **EUROPEAN PATENT SPECIFICATION**

(45) Date of publication and mention of the grant of the patent: (51) Int. Cl.⁷: **B26B21/40, A45D27/38**

05.06.2013 Bulletin 2013/23(21) Application number: **11223223.1**(22) Date of filing: **07.01.2011**(54) **Razor**

Rasierer

Rasoir

(84) Designated Contracting States:

**AL AT BE BG CH CY CZ DE DK EE ES
 FI FR GB GR HR HU IE IS IT LI LT LU
 LV MC MK MT NL NO PL PT RO RS SE
 SI SK SM TR**

(30) Priority:

08.01.2010 GB344566

(43) Date of publication of application:

13.07.2011 Bulletin 2011/28

(73) Proprietor:

**Closhave Co.Ltd.
 52 Willow Road
 London
 NW3 1TP (GB)**

(72) Inventor:

**Willie R. Inkle
 52 Willow Road
 London
 NW3 1TP (GB)**

(74) Representative:

**Lemouton, Sean
 41 Penn Road
 London
 SE29 9AZ (GB)**



Note: Within nine months from the publication of the mention of the grant of the European patent, any person may give notice to the European Patent Office of opposition to the European patent granted. Notice of opposition shall be filed in a written reasoned statement. It shall not be deemed to have been filed until the opposition fee has been paid (Art. 99(1) European Patent Convention).

[0001] The present invention is directed to a razor cartridge for a shaving system.

[0002] Razors for wet shaving systems typically include a razor cartridge carried by a handle, the razor cartridge comprising one or more straight blades. The razor cartridge
5 may be fixedly mounted on the handle, such that the entire razor can be discarded when the blade edges become blunted. Alternatively, the razor cartridge can be detachably connected to the handle, such that a used cartridge can be replaced by a fresh one. Razor cartridges are also commonly called blade units. In the prior art, a razor cartridge typically comprises a support to which further elements are attached, e.g. the blades.
10 The razor cartridge comprises a portion forward of the cutting edge of the blades in the direction of shaving, usually known as a guard, which forms a skin-engaging element comprising the leading skin-engaging surface. This leading skin-engaging surface thus contacts the skin before the blades. The razor cartridge further comprises a portion to the rear of the blades, usually known as a cap, which is a skin-engaging element
15 comprising the trailing skin-engaging surface.

[0003] The skin-engaging surfaces have one or more functions such as definition of shaving geometry, tensioning of skin in the region to be shaved, and/or delivery of shaving aid material during shaving.
20

[0004] Known razor cartridges typically use a relatively rigid polymer material such as polypropylene or polystyrene for the skin-engaging elements.

[0005] The invention is set out in the claims.



[0006] One embodiment of the present invention uses a resilient foam material having a higher coefficient of friction than conventional rigid polymers for the skin-engaging element. When part of, or attached to, the guard, this tensions the skin prior to contact with the blade when the razor cartridge is moved over the skin. This provides more control of the skin, so that cuts are avoided. Further, the position of the hair prior to contact with the blade is improved, such that a close shave is delivered.

10

[0007] Figs. 1 and 2 show razor cartridges of the present invention. Figs. 3 and 4 show blade fencing for use in razor cartridges.

[0008] Fig. 1 is a perspective view of a razor cartridge comprising: blades 13, cap 14 and guard 11 including foam element 12.

15

[0009] Fig. 2 is a cross-sectional view of the cartridge of fig. 1 showing blades 13, cap 14 and guard 11 including foam element 12 having surface 121 for contacting the skin.

20

[0010] The foam material used in the skin-engaging element is a resilient foam. We have found that resilient foams have a higher coefficient of friction than non-resilient foams or conventional rigid plastics made from polymers such as polypropylene or polystyrene. As a result, when the foam material is placed forward of the cutting edges, the skin tends to stretch slightly. This better positions the skin and the hairs thereon prior to contact with the blades 13. The tensioned (stretched) skin does not form bumps, which are often a reason for cuts occurring during shaving since these raised areas may come into contact with the blades 13.

25

[0011] The resilient foam material is preferably selected from polyurethane, mixtures of natural and synthetic rubbers, or biodegradable foam. Polyurethane resilient foam is easy and cheap to produce and is therefore particularly preferred.



[0012] An embodiment of the present invention uses a biodegradable resilient foam. In view of the current tendency towards providing articles which are made from materials having a reduced impact on the environment, the incorporation of such materials goes some way to addressing the consumer's concern about waste due to disposable articles.

5 Advantageously, the razor handle and cartridge may be composed of a rigid material which is also biodegradable. A balance must be found for the biodegradable material between a sufficient degradability and sufficient stability over the lifetime of the disposable article. For a razor, this is typically 1 to 8 weeks, depending on frequency of shaving (e.g. daily facial shaving or once-weekly leg shaving).

10

[0013] EVA copolymer foams or starch copolymer foams are suitable as the biodegradable resilient foam. The same materials (i.e. EVA or starch copolymer) may also be manufactured as rigid plastics suitable for the support structure of the razor. Starch copolymers are advantageous as they are produced from natural materials which are readily available.

15

[0014] The foam element is adhered to the support by means of an adhesive layer, heat sealing or spot welding. Since the foam element acts as explained above due to its high coefficient of friction, the adherence of the foam element to the support is important, so that it does not peel off during use.

20

[0015] Alternatively, a self-adhesive foam may be used to make the foam skin-engaging element. This has the advantage of avoiding the use of a layer of adhesive, as well as avoiding an extra process step in the manufacture of the razor cartridge. Self-adhesive foams are e.g. those made from polyvinyl acetate.

25



[0016] In a further aspect the invention comprises a razor cartridge wherein at least a part of said blade 13 is fenced. Fencing involves covering a part of the blade with a material which creates a small but effective separation between the blade and the skin. Fencing the blade is advantageous, as the movement of the blade over the skin is optimised, such that shaving is smoother and skin cuts and irritation are reduced. The hair cutting effect is not significantly different from that obtained with a continuous (i.e. unfenced) blade when the right proportions of fencing to cutting edge are used.

[0017] The fencing element 2 used in the invention is formed from a flexible sheet 20 having a row of aligned holes 21 spaced at regular intervals 22 as shown in fig. 3. The sheet is made of a plastics material. Plastics materials have a lower coefficient of friction than that of metals, from which the blade is made. This provides for optimum fencing, therefore minimal skin damage.

[0018] As shown in fig. 4, the flexible sheet is folded over the elongated cutting edge and secured to the blade 13 such that the aligned holes 21, also called apertures, coincide with the cutting edge of the blade. The means of securing the sheet to the blade may be, for example, hot melt adhesives or pressure sensitive adhesives.

[0019] The dimensions of the holes in the sheet are of critical importance, so that sufficiently wide portions of the blade are exposed for cutting hairs to provide a shave which is equivalent in cutting efficacy to that of a non-fenced blade. If the exposed parts are too narrow, cutting efficacy is reduced. The fencing divides the cutting edge into portions each having a width of 0.60 - 1.00 mm for maximum cutting efficacy. The intervals between the holes should not be more than 0.25 mm wide. The holes should extend back from the cutting edge by at least 1.70 mm so as to avoid that hairs get trapped under the edges of the holes.



[0020] The fenced blade is attached by conventional means to the razor cartridge which acts as a support.

[0021] The use of such a flexible sheet for the fencing element provides a stable and reliable fencing element which does not tend to get displaced, and hence remains effective over the life of the cartridge.

[0022] When the guard comprising a resilient foam is combined with the fenced blade, a synergistic effect is obtained in terms of reduction of cuts while shaving. At the same time, the system provides a close shave.



Claims:

1. A razor cartridge comprising:
a blade (13) having a straight cutting edge; and
5 a skin-engaging element,
wherein at least a part of said skin-engaging element comprises a resilient
foam material (12).
- 10 2. A razor cartridge according to claim 1, wherein the resilient foam material (12)
is a self-adhesive polyurethane foam.
3. A razor cartridge according to claim 1, wherein the resilient foam material (12)
is arranged to contact and tension the skin forward of the cutting edge, and
15 wherein the resilient foam material is polyurethane or is a biodegradable
starch copolymer.
4. A razor cartridge comprising:
a blade (13) having a straight cutting edge; and
a fencing element (2) comprising a flexible plastics sheet (20) having a row of
20 aligned holes (21) with intervals between the holes of not more than
0.25 mm wide;
wherein said sheet is folded over the cutting edge and is secured to the blade
to expose portions of the cutting edge each having a width of
0.60-1.00 mm.
- 25 5. A razor cartridge according to claim 4, wherein the holes (21) in the flexible
plastics sheet (20) extend back from the cutting edge by at least 1.70 mm.
6. The use in a razor of a resilient foam material, forward of the cutting edge, for
30 tensioning the skin to be shaved.



Figure 1

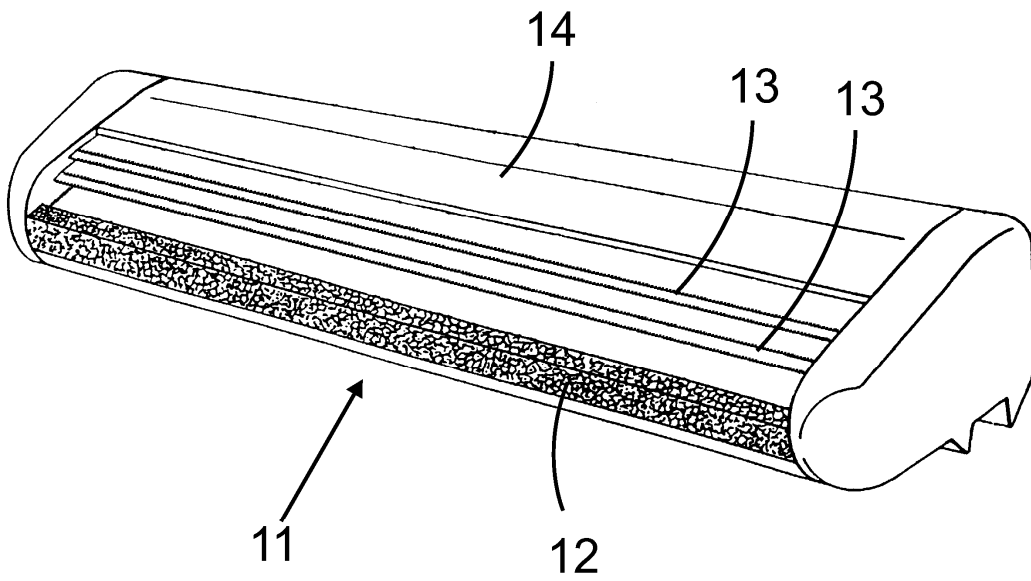

Figure 2

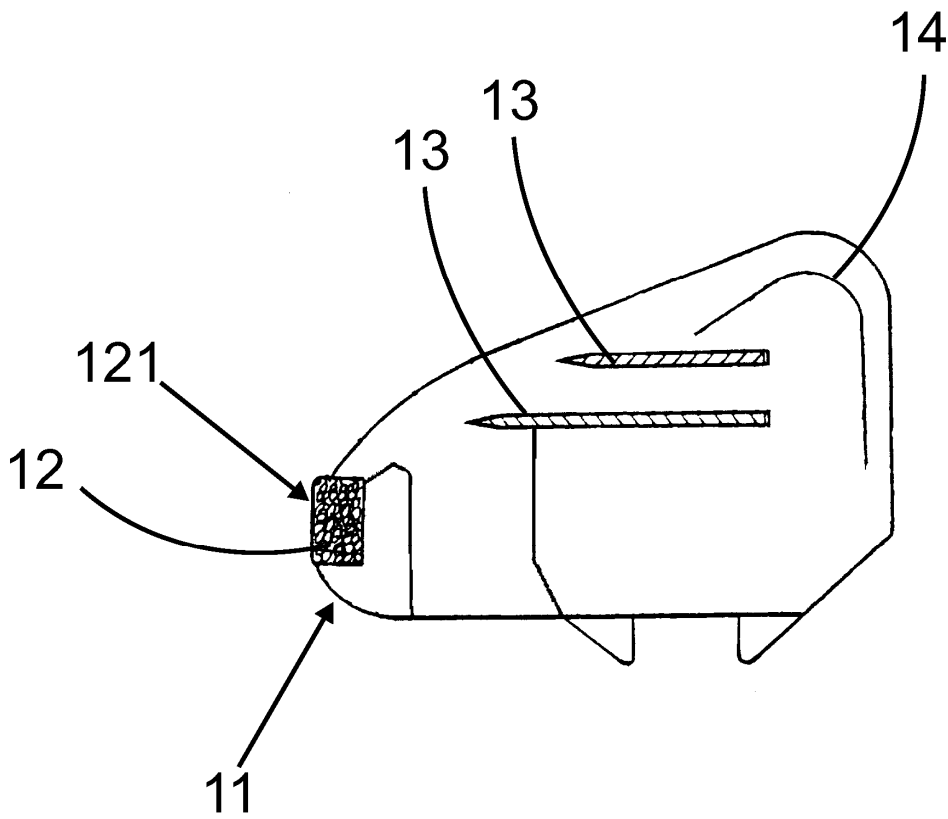

Figure 3

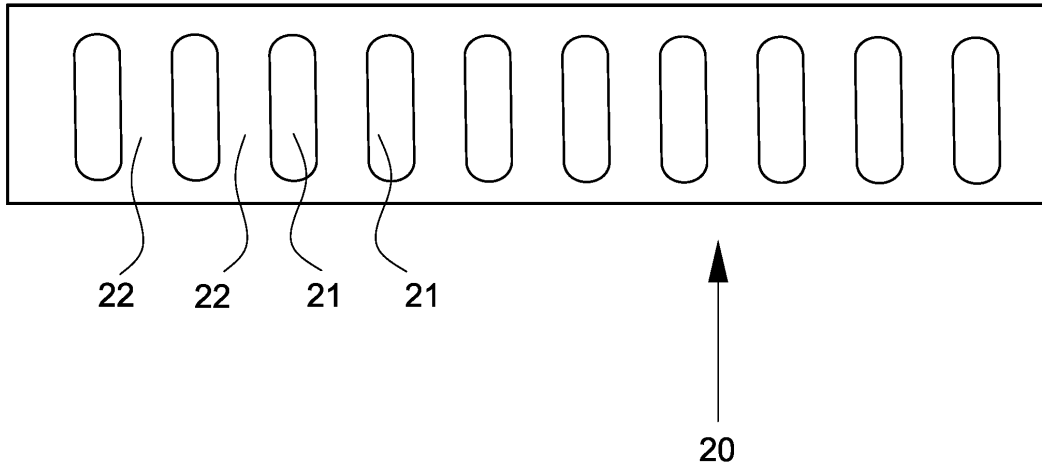
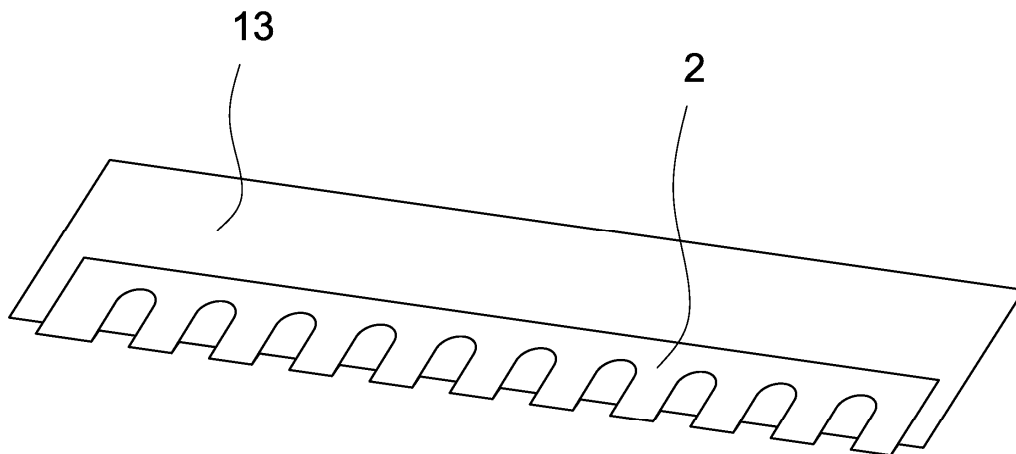

Figure 4



	(19)	European Patent Office	
	(12)	European Patent Application	
	(21)	Application number:	01114441.1
	(11)	Publication number:	EP 1 114 141
5	(22)	Date of filing:	13.09.2001
	(43)	Date of publication:	20.03.2002 Bulletin 2002/12
	(30)	Priority:	15.09.2000 GB 0022808
	(51)	Int. Cl.:	B26B21/40
	(71)	Applicant:	Wilkins & Saward Ltd.
10	(72)	Inventor:	B. Aldycoot, Devon, GB
	(84)	Designated Contracting states:	AT BE CH DE DK ES FR GB IT LI NL

Razor blade with improved performance

15

[0001] The present invention relates to a razor head having fenced blades.

[0002] A recent development in the field of wet shaving relating to the control of skin as it flows past the blades has been the use of wire-wrapped blades. Wire-wrapped
 20 blades comprise at least one metal wire wrapped in spaced intervals around the sharpened leading edge of the one or more blades to control the flow of skin, and reduce skin damage. Such wire wrapped blades provide for separating the cutting edge into a multiplicity of aligned cutting edge portions separated from each other by slightly raised portions. These raised portions are known as fencing. The fencing ensures that
 25 the blade is kept away from the skin surface.

[0003] These techniques have improved shaving performance since abrasion of the skin is less likely due to the metal wire keeping the blade slightly away from the skin surface. However they suffer from the problems of how to position the wire with
 30 accuracy, and how to prevent the wire from moving on the blade edge.



[0004] The present invention relates to an improvement in such fenced blades where the individual cutting edge portions are separated from each other by strips of material rather than wires. The which strips form part of a fencing element.

5 **[0005]** Figs. 1 and 2 show the fencing element of the invention. Fig. 1 shows a flexible sheet 16 with a linear row of apertures 17 and strips 18. Fig. 2 shows the flexible sheet 16 folded over a blade 2 in blade holder 21. Blade holder 21 is incorporated into the support element of a razor head (not shown in the figure).

10 **[0006]** The strips 18 which divide the cutting edge into portions are part of a sheet of flexible material 16 that has a linear row of apertures formed in it. The sheet is folded over and secured to the blade such that the row of apertures coincides with the cutting edge of the blade. The strips between the apertures form the parts extending over the cutting edge. One side of the sheet may have a pressure-sensitive adhesive coating
15 applied thereto, so that this side adheres to the blade when pressed against it.

[0007] The fact that the fencing is a single structure, ie. the flexible sheet, means that the fencing geometry can be predetermined and is stable.

20 **[0008]** The sheet of flexible material is made of metal, cloth, laminated materials etc. Preferred is a metal foil, which is easy to prepare and compatible with the razor blade.

[0009] The width of the apertures in the flexible sheet is preferably in the range 0.50 - 1.20 mm. The strips between the apertures are advantageously no more than
25 0.25 mm wide. Any more than this and too much of the blade length is no longer available for cutting, which reduces shaving efficiency. The length of the apertures in the flexible sheet is preferably 3 to 4 mm, to avoid hair getting trapped between said sheet and the blade.



Claim:

A safety razor blade having a cutting edge and disposed thereon a sheet of flexible material having a row of linear aligned apertures therein, said apertures being separated by strips, said sheet being fixed to the blade such that the apertures coincide with the cutting edge of the blade.

Figure 1

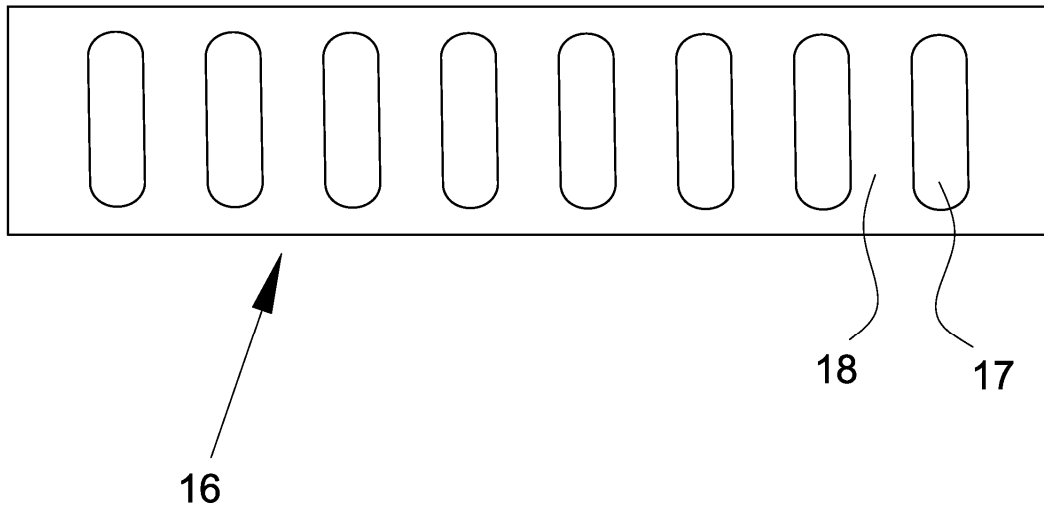
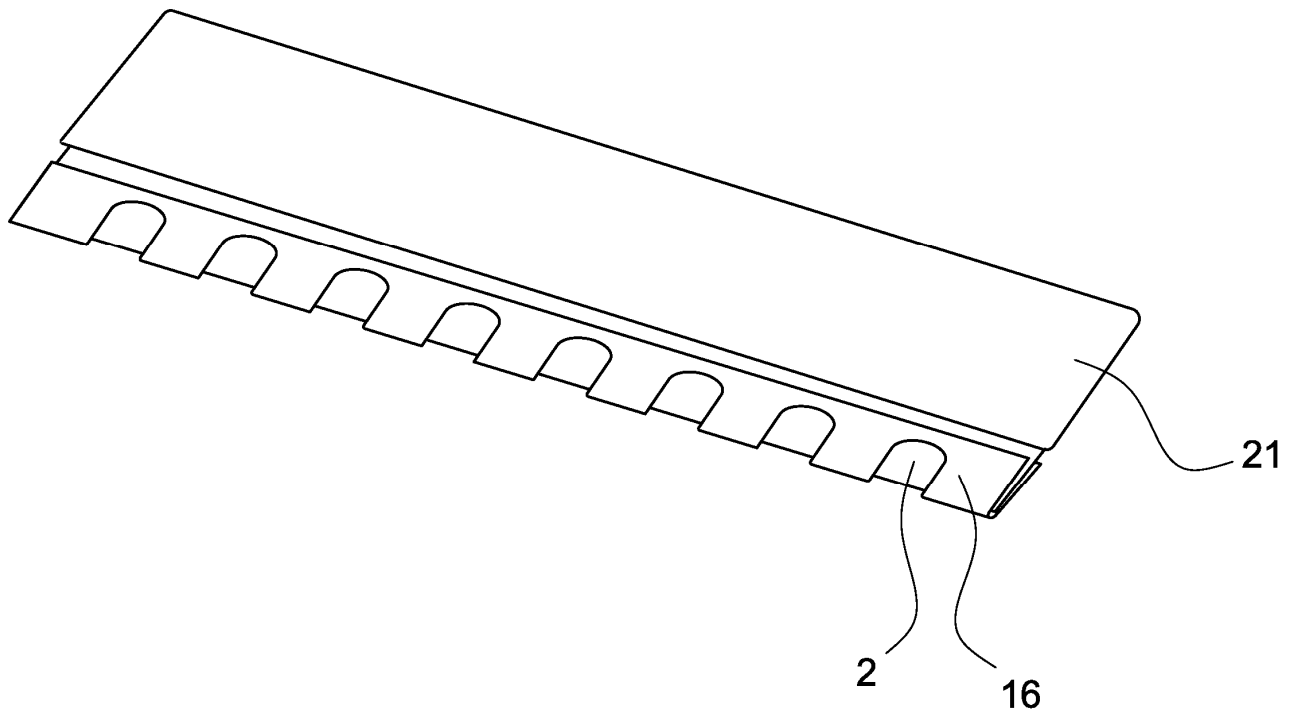

Figure 2



(19) **United States**

(12) **Patent Application Publication**

(21) Application number: **09/727,272**

(22) Filed: **08.12.2000**

5 (10) Publication number: **2002/0025883**

(43) Date of publication: **13.06.2002**

(51) Int. Cl.: **B26B21/20**

(52) U.S. Cl.: **30/346.57**

(72) Inventor: **Bart Wux, Aireyville, GA (US)**

10

Razor cartridge

15

[0001] The present invention relates to a razor cartridge having, carried on a platform, at least one blade and a guard comprising a thermoplastic elastomeric material.

20

[0002] The surface of the guard has a convex shape. In a preferred embodiment, fins of the same material project from said convex surface of the guard member. The fins are thicker at the base and have rounded ends.

25

[0003] The elastomeric material is chosen to provide flexibility in the fins and thus a pleasant tactile sensation while shaving. Commercially-available thermoplastic elastomeric materials such as RUBBON 3 or RIBBIN 25G, both available from the GRUBBER Corporation are suitable. The platform may be made of any conventional rigid plastics material e.g. polypropylene or polystyrene.

[0004] Fig. 1 is a perspective view showing a cartridge according to the invention, whereby an elastomeric guard 30 is shown in place on a platform 40 on which blades 51, 52 are positioned.



[0005] Fig. 2 is a partial cross-sectional view of fig. 1 showing the platform 40 and elastomeric guard 30 with fins 31, 32, 33.

5 [0006] The fins define a guard surface greater than the surface of the parts of the fins in contact with the skin. However, due to the arrangement of the fins in close proximity, the feel on the skin is that of a continuous surface.

10 [0007] The elastomeric material has a higher coefficient of friction than that of the rigid platform material, which contributes to a pleasant traction force on the skin. This is advantageous as the skin is stretched slightly, thereby reducing the risk of cuts while shaving.

15 [0008] To further reduce the potential for skin damage while shaving, the blades may be wire-wrapped. This wire-wrapping provides protection against cuts. Such wire-wrapped blades may be as efficient as non-wrapped blades in terms of shaving.

[0009] Fig. 3 shows a perspective view of a cartridge according to the invention, whereby the blades are fenced with wire wrapping 60.

20 [0010] An important feature of the wire fencing is that it should have a low coefficient of friction to allow the blade portion of the razor to move smoothly over the skin. The wire may be a metal wire such as a copper, silver or stainless steel wire. Instead of the metal wire, a plastics wire may be used. Suitable plastics are polyamide, nylon, polyethylene and polystyrene. Plastics have the advantage that they have a lower
25 coefficient of friction than metals, and thus increase the effect of the fencing.

[0011] Such wires may be given positional stability by spot welding or gluing them to the blade at a location back from the blade edge. Further, the edge of the blade opposite to the cutting edge may have a number of evenly spaced notches which guide the wires.



Claim:

A razor cartridge comprising :
at least one blade,
a guard comprising a thermoplastic elastomeric material.

Figure 1

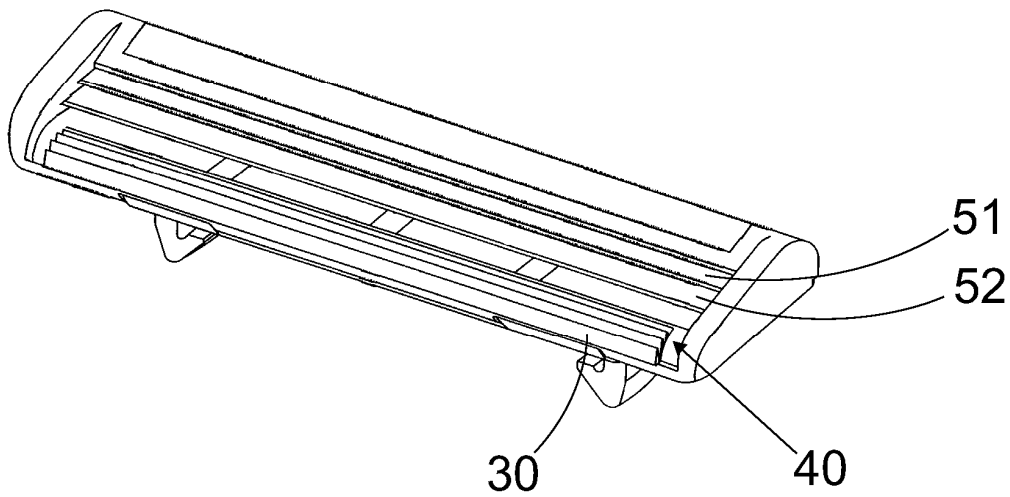

Figure 2

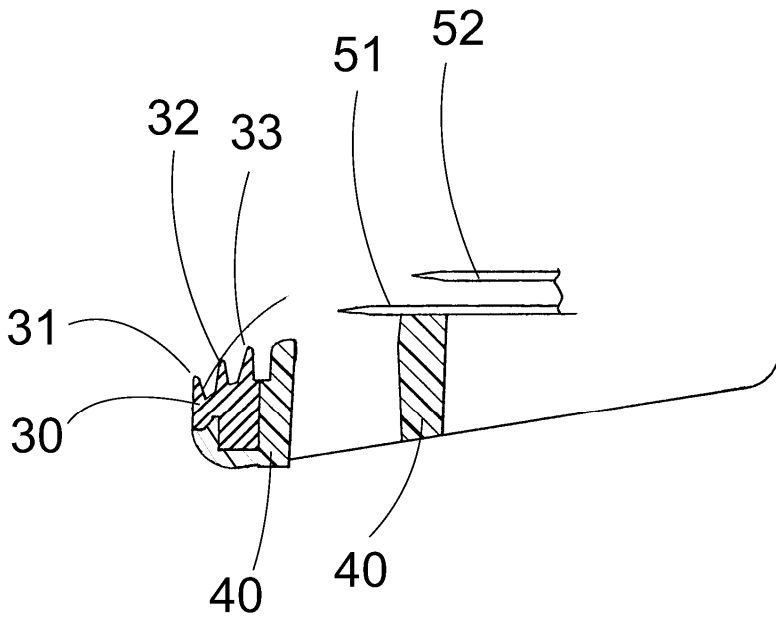
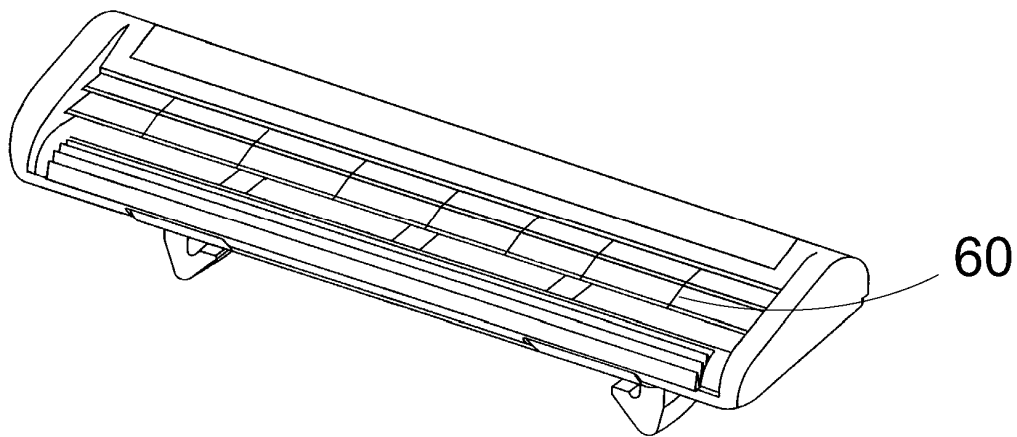

Figure 3



	(19)	Canadian Intellectual Property Office	
	(21)	Application number:	2 020 300
	(11)	Publication number:	CA 2 020 300
	(22)	Date of filing:	12.04.1998
5	(43)	Date of publication:	10.11.1999
	(51)	Int. Cl.:	B26B21/40
	(71)	Applicant:	Chauve & Co. 3 Satin Drive, Québec, CA
10	(72)	Inventor:	M. Labarbe

Skin lubricating device

[0001] The present invention is directed to a lubricating device for the skin. The lubricating device may be an article for care of the skin, such as part of a mitt or glove. In a preferred embodiment, it may be part of a razor assembly, preferably as part of the blade unit.

[0002] Fig. 1 shows a sectional view of the device 1.

[0003] The device 1 comprises a porous matrix 2 impregnated with lubricating agent, and a water-insoluble permeable sheet 3. The sheet provides a protective layer for the porous matrix and is essential for the skin feel of the device. The sheet is adhered to one side of the impregnated porous matrix, and the lubricating agent may diffuse through the permeable sheet when the device is moistened. The porous matrix is fixed to a substrate 4, which is e.g. a glove substrate or razor blade unit.

[0004] The device is preferably an integrated part of a razor blade unit, supported in the cap or guard of the blade unit, e.g. as a strip adhered to the cap. When wetted during shaving, a part of the lubricating composition will diffuse through the permeable sheet and lubricate the skin. It is thus important that the lubricating agent is water-soluble.



[0005] The porous matrix is water-insoluble and is preferably in the form of a spongy material. Such spongy materials are for example synthetic foams, such as polyethylene foams. These are deformable, and recover their shape when the deforming force is removed. Such behaviour is known as resilient behaviour.

5

[0006] Fig. 2 shows a view of a razor blade unit comprising as an integrated part a device 1 of the present invention. The blade unit 20 comprises a guard bar 22, blade 23 and cap 40 to which the lubricating device 1 is attached.

10 **[0007]** Any suitable water-soluble lubricating agent may be used. Lubricating agents may be polyethylene oxides, polyacrylamides etc., preferably polyethylene oxides.

[0008] The razor assembly comprising the blade unit preferably has an integrated handle. The assembly may be produced by conventional techniques. Preferably, a major portion of the handle is a foamed polymeric material, which is moulded onto the rigid polymeric material which forms the head and the body of the razor. Appropriate moulding techniques are known in the art.

20 **Claim:**

A skin lubricating device comprising a porous matrix impregnated with lubricating agent, and a water-insoluble permeable sheet.



Figure 1

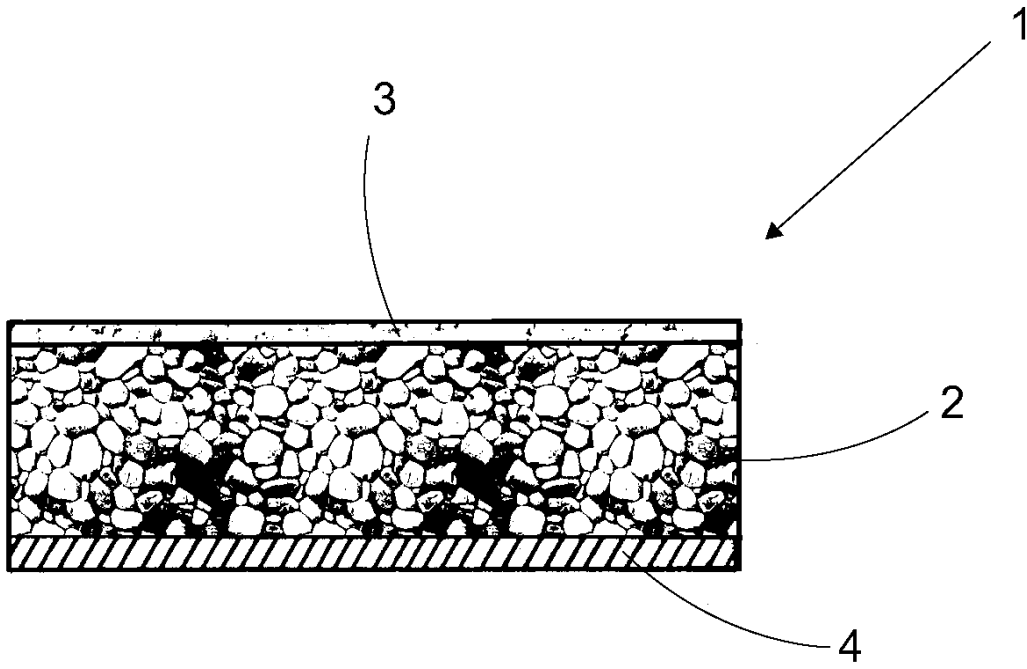
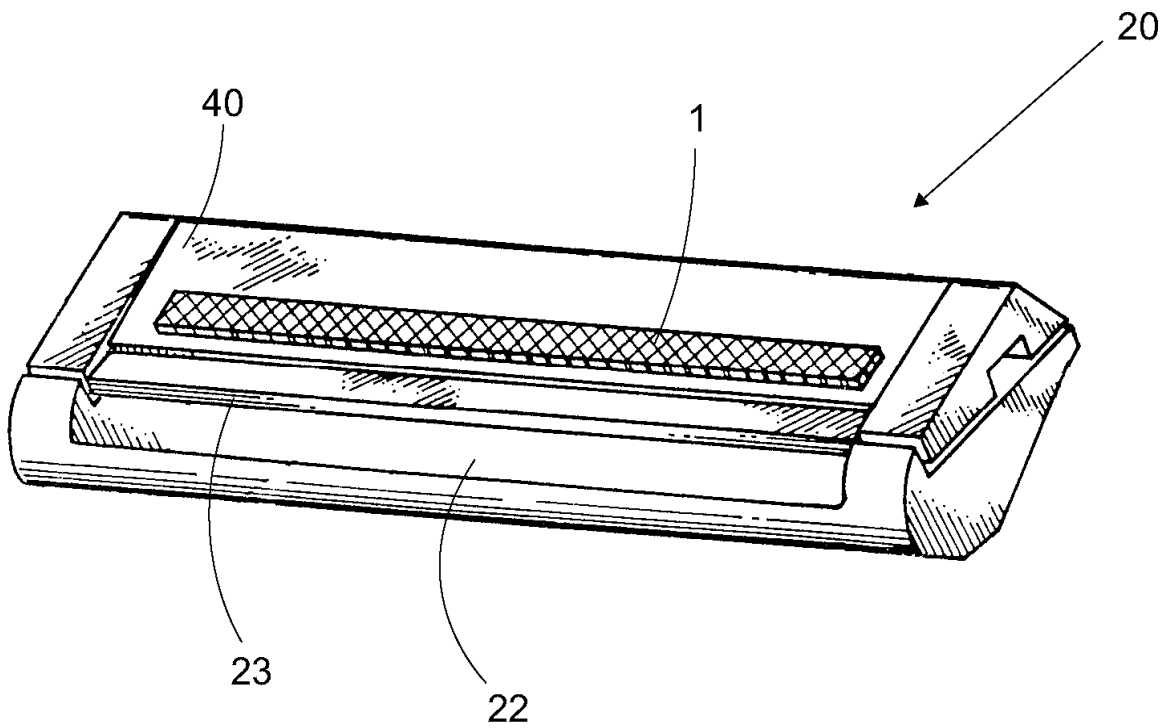

Figure 2



(19) German Patent and Trademark Office

(21)	Application number:	101 40 330.2
(11)	Publication number:	DE 101 40 330
(22)	Publication number:	12.08.2001
5 (45)	Date of publication:	03.03.2003
(51)	Int. Cl.:	B26B21/40
(71)	Applicant:	Schafkopf GmbH
(72)	Inventor:	Veronika Haorig

10 Safety razor

[0001] The present invention is a novel form of safety razor in which a multi-edged blade is mounted in a holder of foam material.

15 **[0002]** The razor is primarily designed for use by women, for example to remove hair from the legs while bathing. The holder of foam material, which is readily deformable, is easy to grasp even in soapy bath water and also easily follows the contours of the skin. It does not become slippery since the soapy bathwater does not remain on the surface of the holder but soaks into the foam. The razor is held in the manner of a sponge, and
20 passed over the skin surface for example in small circular motions. It has been found that the action of shaving using this razor is very comfortable, and little different in feel to using a bath sponge.

[0003] The razor is usable repeatedly, since the foam material recovers its original
25 shape after use. The razor is thus usable until the blades are dulled.

[0004] Figures 1 and 2 show razors according to the invention.



[0005] Foam materials used in the invention have a higher coefficient of friction than rigid plastics which are commonly used for shaving articles. Any polymeric material may be made into a foam. The use of such a material in the present invention ensures that in the slippery conditions of a bath, the user still has sufficient grip on the safety razor to use it comfortably.

[0006] It is thought that the use of such a foam material contributes to stretching the skin slightly such that hair on the legs is advantageously positioned for cutting by the cutting edges. Further, the pleasant traction feeling masks the unpleasant feeling of the blades cutting the hairs.

[0007] Polymers to be used in producing the foams for the razor according to the invention are e.g. synthetic polymers such as polyurethane or polyethylene. Polyurethane foams are cheap and easy to produce.

[0008] Fig. 1 shows a razor comprising a rounded holder 1 of foam material, having set in its upper face a blade 2 in the form of a foil of conventional blade material, such as stainless steel, having a plurality of circular apertures whose edges are sharpened. The foil is capable of flexing with the holder material to follow skin contours.

[0009] Fig. 2 shows a preferred embodiment of the razor with a holder 1, in which the blade 2 is supported on a rigid plastics frame 3 of polypropylene, in order to provide some stability to the razor.

Claim:

A safety razor in which a multi-edged blade is mounted in a holder of readily deformable material surrounding the blade.



Figure 1

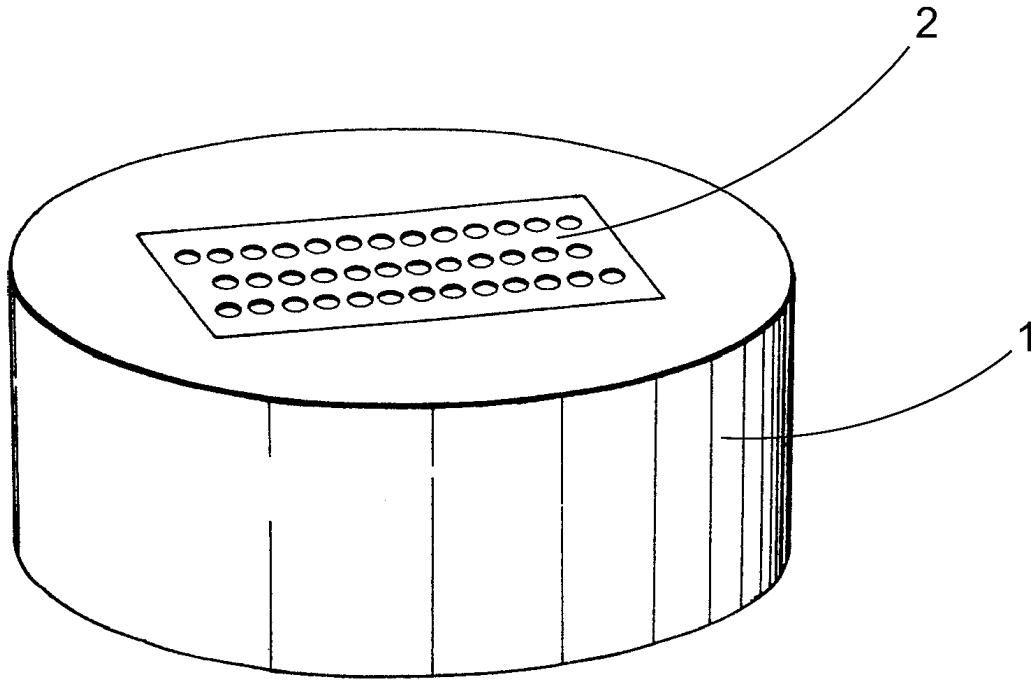
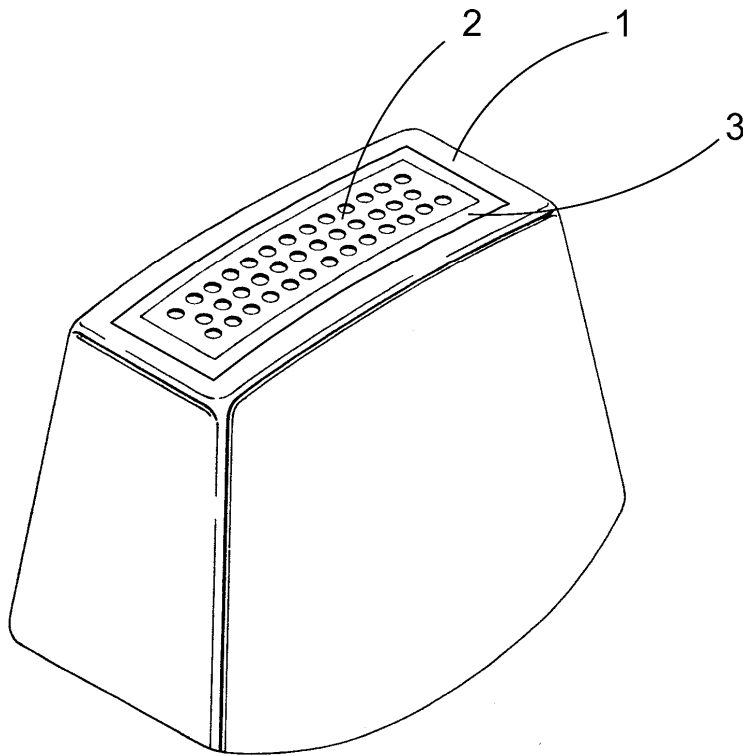

Figure 2



- (19) **Australian Patent Office**
- (21) Application number: **AU 2010454545**
- (22) Date of filing: **14.06.2010**
- (30) Priority data:
- 5 (31) Nummer: **PR 4343**
- (32) Date: **15.06.2009**
- (33) Country: **AU**
- (43) Publication date: **04.01.2011**
- (51) Int. Cl.: **B26B21/40, A45D27/460**
- 10 (71) Applicant: **Closhave Co. Ltd.**
- (72) Inventor: **G. Lette, W. R. Inkle**

Shaving System

15 **[0001]** The present invention relates to a system for shaving the body. More particularly, the present invention relates to a razor system including a razor, a liquid and optionally shaving gel or foam.

20 **[0002]** The process of shaving can be uncomfortable due to cuts received during shaving, and also irritation of the skin due to the pull of the razor on the skin and the force required to cut the hairs. Cuts are worsened due to corrosion of the razor blade on prolonged or repeated contact with water during the shaving process.

25 **[0003]** The present invention provides a complete system comprising a razor and a liquid bath. The razor comprises razor blades mounted on a support and a retentive strip. The razor is stored in a liquid bath when not in use, which protects the razor blades from corrosion. At the same time, the liquid bath acts to clean debris from the razor from the previous shave.



[0004] The liquid bath also cools the blade by evaporation of the liquid when the razor is taken out of the bath. Thus when the user applies it to the skin for the next shave, it is cool and imparts a pleasant feeling to the skin.

5 **[0005]** A razor including a retentive strip of material 12 is shown in Fig. 1. This retains a quantity of the liquid such that it is also applied to the user's skin.

10 **[0006]** The retentive strip is a sponge material, which is either a natural sponge, or a synthetic sponge such as a foamed polymer. After use in shaving, the material must be able to retain its shape for further uses, i.e. recover its original shape if deformed. Such foams have a high coefficient of friction, and thus may pull on the skin. However, when used in combination with the liquid bath of the invention, this does not happen and the razor glides smoothly over the skin.

15 **[0007]** A material which has the desired properties is a polyurethane foam. One type of polyurethane foam is also self-adhesive. This also has the advantage of ease of attachment to the razor support because no extra adhesive is necessary.

20 **[0008]** Preferably, the foamed polymeric material is a biodegradable foam. These have the advantage of reducing the quantity of plastics needing incineration or other processing. Polymers such as starch based copolymers or EVA copolymers are suitable. If biodegradable foams are used, a balance has to be struck between the biodegradability of the foam, and the requirement that the foam does not start to disintegrate during the use lifetime of the article.



[0009] The liquid comprises an extract of witch hazel (*Hamamelis virginiana*), which is an astringent and antioxidant. The extract of witch hazel is an alcoholic extract, typically in ethanol or isopropanol. The alcohol helps to break down substances in the bath which may otherwise corrode the razor blade. The extract of witch hazel due to its astringent properties constricts the blood vessels in the skin. This gives a smooth feel to the skin and reduces bleeding from any cuts incurred during the shave.

[0010] Fig.1 shows a razor 1 according to the inventive system. This is a conventional form of razor modified with a sponge strip 12 behind a pair of blades 13 and 14. The strip 12 is disposed behind the blades so as to trail the cutting edges and provide the astringent composition to the skin immediately after the blades have cut the hairs.

[0011] The razor head may also have in the blade portion a series of fencing elements to protect the user against abrasion from the blades while allowing effective shaving. Such fencing elements typically take the form of protective elements 15 made of plastics or metal (see Fig. 1). The fencing elements may also be in the form of a sheet punched with a line of holes which are placed along the blade edge. This sheet is typically made of plastics or plastics laminated with metal foil for extra strength.

[0012] Fig. 2 shows a system according to the invention wherein the razor head 1 is stored in a bath 2 comprising the liquid 21. The liquid is periodically replenished or replaced.

[0013] The amount of the extract of witch hazel in the liquid is not critical, as long as it is sufficient to achieve the desired effects. The liquid may comprise further cooling or astringent agents, such as menthol derivatives, or other skin care products.



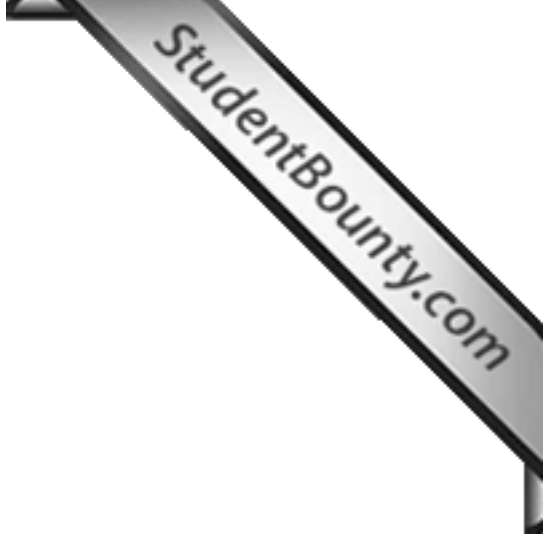

Claim:

5

A shaving system comprising
a razor having a retaining means for liquid and
a bath comprising liquid
wherein the liquid comprises witch hazel extract.



Figure 1

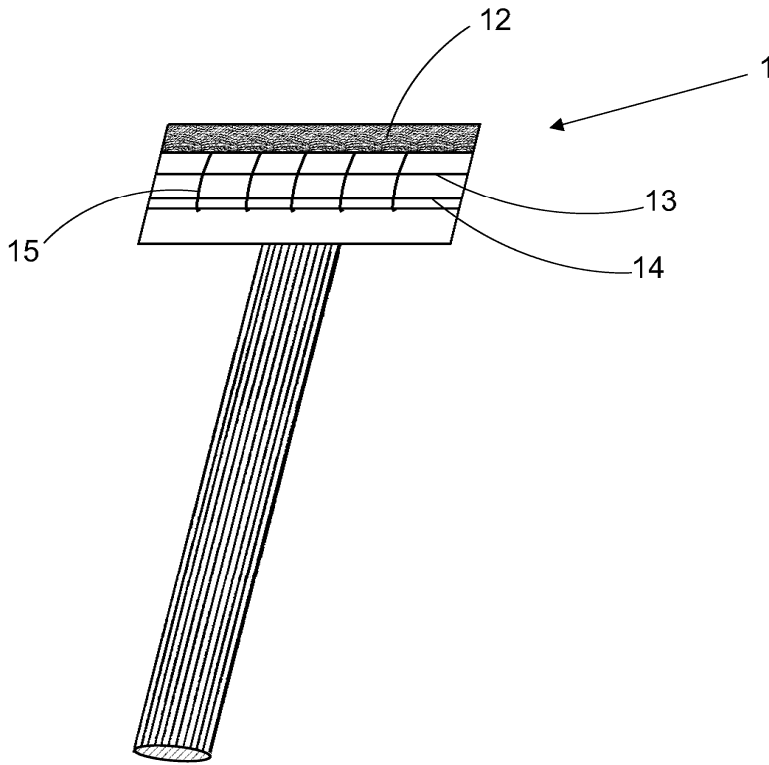
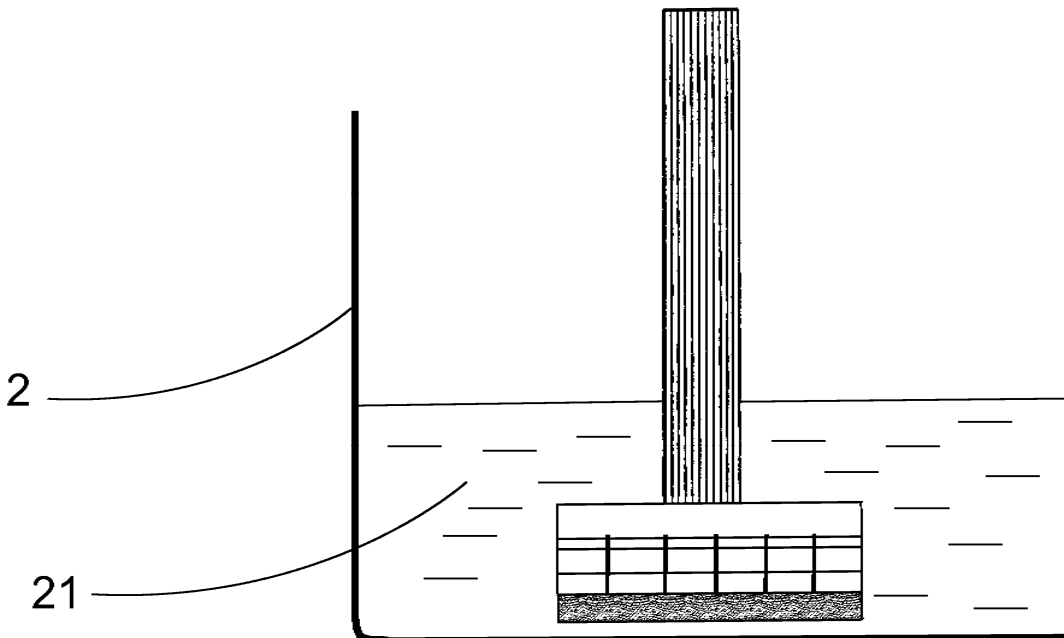

Figure 2



Notes to the notice of opposition (EPO Form 2300)

Although the opposition form is not mandatory for the purpose of filing a notice of opposition, it specifies all the information required for such a notice to be admissible and hence facilitates the formulation and processing of the opposition. In stating and explaining the grounds for opposition, the opponent is free to comment as he wishes.

Explanatory notes to the various sections:

I. Patent opposed

Under **Patent No.** the number of the European patent against which opposition is filed (Rule 76(2)(b) EPC) must be given.

If known, the **application number and the date on which the Patent Bulletin mentions the grant** (Art. 97(3) EPC) should also be given. The latter makes it easier to monitor compliance with the opposition period.

The **title of the invention** must be given (Rule 76(2)(b) EPC); it should be indicated **as shown on the cover page of the printed patent specification** under item 54.

II. Proprietor of the patent

Where there are **several** patent proprietors, it is sufficient for the proprietor first named in the patent specification (under item 74) to be given.

III. Opponent

The **name, address and nationality** of the opponent and the **state** in which his residence or principal place of business is located must be given, in accordance with Rule 41(2)(c) EPC (Rule 76(2)(a) EPC). If the identity of the opponent has not been established by expiry of the opposition period, such deficiency can no longer be remedied (decision of the Technical Board of Appeal T 25/85, OJ EPO 1986, 81).

IV. Authorisation

If the opponent has appointed a **representative**, his name and the address of his place of business must be given, in accordance with Rule 41(2)(c) EPC (Rule 76(2)(d) EPC). If **several** professional representatives are appointed, only one representative to whom notification is to be made should be named. Any further representatives must be named in an annex (please put a cross in the appropriate box). In the case of an association of representatives, only the name and address of the association must be entered (see Rule 143(1)(h)).

of the EPC contracting states must be represented and act through his representative (Art. 133(2) EPC). Professional representation before the EPO may only be undertaken by professional representatives (Art. 134(1) EPC) or legal practitioners entitled to act as professional representatives (Art. 134(8) EPC).

Natural or legal persons having their residence or principal place of business within the territory of one of the EPC Contracting States may also be represented in opposition proceedings by an **employee**, who must, however, be authorised (Art. 133(3), first sentence, EPC). In this case notification will be made to the opponent (not the employee) unless a professional representative has also been authorised.

To avoid delaying the proceedings, any authorisation which has to be filed should if possible be enclosed with the opposition. Under Rule 152(1) EPC in conjunction with the decision of the President of the EPO dated 12 July 2007, listed professional representatives identifying themselves as such normally no longer need to file signed authorisations (cf. Special edition No. 3, OJ EPO 2007, L.1.). These are, however, required from legal practitioners and employees who are not professional representatives and are acting for the opponent under Articles 134(8) and 133(3), first sentence, EPC respectively. If they do not file an authorisation, the EPO will ask them to do so within a specified period. Failure to comply will result in any procedural steps performed by the practitioner or employee being deemed not to have been taken (Rule 152(6) EPC) – which means that the notice of opposition will be considered not to have been filed.

V. Statement of the extent to which the patent is opposed

The notice of opposition must contain a statement of the extent to which the European patent is opposed (Rule 76(2)(c) EPC). If the opposition is not filed against the patent as a whole (place a cross in the appropriate box), the number(s) of the claims (as in the patent specification) which the opponent considers to be affected by one or more of the grounds for opposition must be given.

VI. Grounds for opposition

The alleged grounds for opposition (Art. 100 EPC) must be indicated by a cross in the appropriate box(es).

Under the heading of non-patentability (Art. 100(a) EPC) the most frequently cited grounds for opposition are lack of novelty and lack of inventive step, for

otherwise gives the opponent ample scope for indicating other possible grounds for opposition. Under the heading “other grounds” the following Articles may be cited in the box provided: 52(1) and 57; 52(2); 53(a); 53(b); 53(c) EPC.

A full list of grounds for opposition is given in Article 100 EPC. The following in particular are not admissible grounds: lack of unity of invention (Art. 82 EPC), lack of clarity in the claims (Art. 84 EPC) and prior national rights (Art. 139(2) EPC).

For general information on grounds for opposition see Guidelines for Examination in the EPO, D-III, 5.

VII. Facts and arguments presented in support of the opposition

The notice of opposition must contain an indication of the facts and evidence presented in support of the opposition (Rule 76(2)(c) EPC) and, where documents are cited, an indication of the relevant part(s) (Guidelines D-IV, 1.2.2.1).

The facts, with the relevant arguments and evidence, in support of the opposition must be presented on a separate sheet enclosed as an annex to the Form (indicated by a pre-printed cross in the box).

The fact that the evidence is listed separately in Section IX does not anticipate the presentation of facts, evidence and arguments but merely makes for greater clarity and simplifies processing of the dossier. Section IX of the Form (Evidence presented) may of course always be referred to in this presentation.

Where documents are cited in shortened form, the rules set out in the Guidelines B-X, 9.1 should be followed.

VIII. Other requests

This section may be used for example to request oral proceedings or a file inspection.

IX. Evidence

Published documents cited as evidence (e.g. patent specifications) must be entered under “Publications” in the spaces provided – preferably in order of importance. They should be cited in the manner described in Guidelines B-X, 9.1.

Opponents should also indicate the parts of the document on which the opposition is based (this information has to be given anyway in the statement of facts and arguments – see notes to Section VII above).

Other evidence (e.g. witnesses, affidavits, company brochures, test or expert reports) must be cited under “Other evidence” (for public prior use: place, time, nature – see Guidelines G-IV, 72; D-IV, 1.2.2.1(v);

room, the evidence can simply be listed, with an indication of where in the statement of grounds the relevant particulars appear (e.g. “Witness ..., page 5”).

Documents cited by a party to opposition proceedings must be filed (including publications already cited in the European patent specification) with the notice of opposition or other written submission. This will avoid an invitation from the EPO for subsequent filing thereof. If they are neither enclosed nor filed in due time on invitation, the EPO may ignore any arguments based on them (Rule 83 EPC).

X. Payment of opposition fee

The opposition fee must be paid within the opposition period. Notice of opposition is not deemed to have been filed until the opposition fee has been paid (Art. 99(1) EPC). With regard to what constitutes the date to be considered as the date on which payment is made, see Article 7 of the Rules relating to Fees and the guidance on payment methods in the Official Journal.

XI. List of documents enclosed

Please indicate which documents are enclosed by crossing the relevant box.

XII. Signature

If the opponent is a legal person and the notice of opposition is not signed by the representative, it must be signed:

- (a) either by a person entitled to sign under the law or the opponent’s statute, articles of association or the like, with an **indication of the capacity of the person doing so**, e.g. Geschäftsführer, Prokurist, Handlungsbevollmächtigter; chairman, director, company secretary; directeur, fondé de pouvoir (Art. 133(1) EPC), in which case no authorisation need be filed;
- (b) or by another employee of the opponent, provided the latter’s principal place of business is in a contracting state (Art. 133(3), first sentence; Rule 152(1) EPC), in which case an authorisation must be filed.

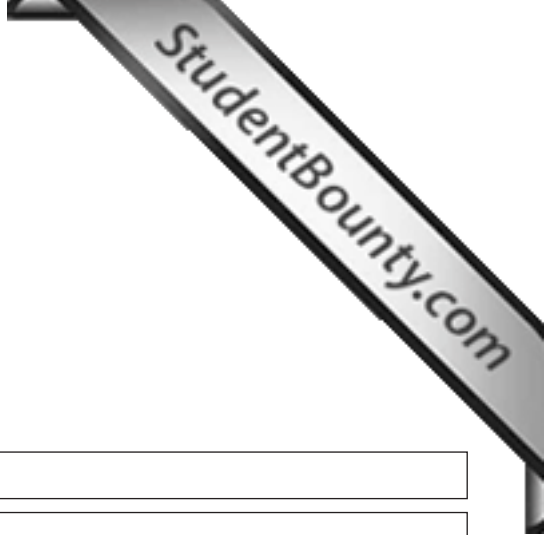

Notice of opposition to a European patent

I. Patent opposed

Patent No.

Application No.

Date of mention of the grant in the European Patent Bulletin (Art. 97(3), Art. 99(1) EPC)

Title of the invention

II. Proprietor of the patent

first named in the patent specification

Opponent's or representative's reference
(max. 15 keystrokes)

III. Opponent

Name

Address

State of residence or of principal place of business

Nationality

Telephone/Fax

<input type="text"/>	<input type="text"/>
----------------------	----------------------

Multiple opponents
(see additional sheet)

IV. Authorisation

1. Representative

(name only one representative or name of association of representatives to whom notification is to be made)

Address of place of business

Telephone/Fax

<input type="text"/>	<input type="text"/>
----------------------	----------------------

Additional representative(s)
on additional sheet/see authorisation

2. Name(s) of employee(s) of the opponent authorised to act in these opposition proceedings under Art. 133(3) EPC

Authorisation(s) to 1./2. not considered necessary

has/have been registered under No.

is/are enclosed

V. Opposition is filed against

• the patent as a whole

• claim(s) No(s).

VI. Grounds for opposition:

Opposition is based on the following grounds:

(a) the subject-matter of the European patent opposed is not patentable (Art. 100(a) EPC) because:

• it is not new (Art. 52(1); Art. 54 EPC)

• it does not involve an inventive step (Art. 52(1); Art. 56 EPC)

• patentability is excluded on other grounds, i.e. Article

Art.

(b) the patent opposed does not disclose the invention in a manner sufficiently clear and complete for it to be carried out by a person skilled in the art (Art. 100(b) EPC; see Art. 83 EPC).

(c) the subject-matter of the patent opposed extends beyond the content of the application/of the earlier application as filed (Art. 100(c) EPC, see Art. 123(2) EPC).

VII. Facts (Rule 76(2)(c) EPC)

presented in support of the opposition are submitted herewith on a separate sheet (annex 1)

VIII. Other requests:

IX. Evidence presented

Evidence is enclosed
will be filed at a later date

A. Publications:

1
Particular relevance (page, column, line, fig.):

2
Particular relevance (page, column, line, fig.):

3
Particular relevance (page, column, line, fig.):

4
Particular relevance (page, column, line, fig.):

5
Particular relevance (page, column, line, fig.):

6
Particular relevance (page, column, line, fig.):

Continued on additional sheet

B. Other evidence

Continued on additional sheet

Please do not use

X. Payment of the opposition fee is made

- as indicated in the enclosed voucher for payment of fees and costs (EPO Form 1010)
- via EPO Online Services

XI. List of documents

Enclosure No.

- 0 Form for notice of opposition
- 1 Facts (see VII.)
- 2 Copies of documents presented as evidence (see IX.)
 - a Publications
 - b Other documents
- 3 Signed authorisation(s) (see IV.)
- 4 Voucher for payment of fees and costs (see X.)
- 5 Additional sheet(s)
- 6 Other

Number of sheets

Please specify here:

XII. Signature of opponent or representative

Place

Date

Signature

Name (block capitals)

In case of legal persons, signatory's position within company