

EUROPEAN QUALIFYING EXAMINATION 2013

Paper C

This paper comprises:

- | | |
|--|-----------------|
| * Letter from opponent to professional representative | 2013/C/EN/1-2 |
| * Annex 1 | 2013/C/EN/3-10 |
| * Annex 2 | 2013/C/EN/11-13 |
| * Annex 3 | 2013/C/EN/14-16 |
| * Annex 4 | 2013/C/EN/17-20 |
| * Annex 5 | 2013/C/EN/21-24 |
| * Form 2300: Notice of opposition to a European patent | |

Mr. Hunt
Toleman Ind.
40026 Imola
ITALY

Mr. Lauda
European Patent Attorney
53520 Meuspath
GERMANY

26.02.2013

Dear Mr. Lauda,

Please file an opposition against European patent EP 3 456 789 B1 (Annex 1) in the name of my company. Our search has revealed the attached documents (Annexes 2-5) which may be of relevance.

In a file inspection we have discovered that Annex 1 was filed as the application EP 3 456 789 A1, which is a divisional application from the patent application EP 2 345 678 A1, which is itself a divisional application from the patent application EP 1 234 567 A1. All three applications have been validly filed.

During this file inspection we have checked the original content of all the European application files mentioned above as well as Annex 1. The three applications as filed and Annex 1 are all exactly the same except for the following differences:

- the subject-matter of paragraph [0017] and of claim 5 of Annex 1 is missing in EP 2 345 678 A1.

Yours truly,
J. Hunt



Enclosures:

Annex 1: EP 3 456 789 B1

Annex 2: Magazine "Automotive Safety"; Kurtis Kraft Publications, 46222 Indiana, USA, Ed. 2/1997, "Pyrotechnical gas generating systems",
Authors: J. Unser and J. Siffert

Annex 3: EP 112233

Annex 4: FR 1 212 121

Annex 5: US 2,222,421 B1



(19)  **Europäisches Patentamt**
European Patent Office
Office européen des brevets

(11) **EP 3456789**

(12) **EUROPEAN PATENT SPECIFICATION**

(45) Date of publication and mention of the grant of the patent: (51) Int. Cl.⁷: **B60R21/16**

09.06.2012 Bulletin 2012/24

(21) Application number: **08 915 813**

(22) Date of filing: **25.04.2005**

(54) **Airbag**

Airbag

Airbag

(84) Designated Contracting States:

DE ES FR GR GB IT PT

(73) Proprietor:

Cooper Industries

(60) Publication number(s) of the earlier application(s) in accordance with Art. 76 EPC:

EP 2 345 678 A1

EP 1 234 567 A1

(72) Inventor:

J. Clark
Am Motodrom
68766 Hockenheim (DE)

(43) Date of publication of application:

02.11.2006 Bulletin 2006/44

(74) Representative:

L. Bandini
Bd. Louis II
98000 Monaco (MC)



Note: Within nine months from the publication of the mention of the grant of the European patent, any person may give notice to the European Patent Office of opposition to the European patent granted. Notice of opposition shall be filed in a written reasoned statement. It shall not be deemed to have been filed until the opposition fee has been paid (Art. 99(1) European Patent Convention).

[0001] The present invention relates to an airbag module for protecting a vehicle occupant upon frontal impact.

5 **[0002]** Airbag modules known in the art consist of a control unit, a gas generator and a cushion, i.e. an inflatable bag. In a situation of imminent impact, the control unit activates the gas generator, which delivers an appropriate quantity of gas that fills the cushion to a certain pressure in milliseconds. The pressurized cushion expands between the occupant and an object, for example the dashboard or the steering-wheel, thereby providing a decelerating and cushioning effect that will protect the occupant upon
10 impact.

[0003] During the collision, the occupant is forced against the cushion, thereby compressing the cushion. As a result, the pressure inside the gas-filled cushion is increased. In the prior art, during major impacts (for example, when an occupant is not
15 wearing a seat belt) the pressure may rise in the cushion to such an extent that the cushion becomes so hard that it can cause injuries to the occupant.

[0004] The aim of the present invention is to avoid impact injuries.

20 **[0005]** Figure 1 shows the deployment of an airbag according to the invention.

[0006] Figures 2 (a) - (c) show a fully deployed airbag and a valve according to the invention.

25 **[0007]** Figures 3 (a) - (c) show the airbag according to the invention when the occupant strikes against it and the valve according to the invention.

[0008] Figure 4 shows a gas generator according to the invention.



[0009] The airbag module of the invention comprises a control unit (not shown), control its activation, a gas generator 1 and a fabric cushion 2. Prior to being placed inside the module, the fabric cushion 2 is rolled up in such a way that when the airbag is activated, the fabric rolls out along a deployment surface, for example the
5 windscreen 13, as seen in Figure 1. If the airbag is stored in this way, the windscreen 13 is covered rapidly at a very early inflation stage. The deployment time is reduced, thereby increasing occupant safety.

[0010] As seen in Figures 2 (a) - (c) the fabric cushion 2 comprises a pressure
10 regulating valve 3, i.e. a device that regulates the pressure inside the fabric cushion 2 by regulating the flow of gas exiting the fabric cushion. This adapts the hardness of the cushion 2 according to the situation. According to a preferred embodiment, the valve may be an elastic membrane, i.e. an expandable and pliable barrier that changes shape when exposed to an outside force or pressure. The elastic membrane may be an elastic
15 strip 10 made of silicone attached to the cushion 2 by a rubber-based adhesive 9, which creates a bond with increased strength compared to other attachment means such as stitches. The strip 10 covers a vent-hole 5 provided in the wall of the fabric cushion 2. The vent-hole 5 is an opening through which gas can exit the chamber defined by the
20 cushion 2. As seen in Figure 2, during the expansion of the cushion, and before the occupant hits the cushion, the strip 10 closes the vent-hole 5, because the pressure inside the cushion chamber is not enough to deform the strip. Therefore, no gas is vented, which allows a rapid expansion of the airbag.



[0011] As seen in Figure 3, when the occupant of the vehicle is thrown forward against the cushion 2 due to a rapid deceleration of the vehicle, the cushion 2 will be compressed with a large force, creating a rise in pressure. If, due to the magnitude of the impact, the pressure surpasses a certain threshold, the elastic strip 10 will then bow outwards and open the vent-hole 5. This allows gas 11 from inside the cushion to be liberated and relieves the pressure in the cushion during its compression. This prevents the airbag from becoming excessively hard during high impact collisions, and reduces the risk of the occupant being injured. The cushioning effect is therefore improved.

[0012] The fabric cushion of the airbag may be made of polyester and coated with a polyamide resin. This coating gives the fabric a better heat resistance when compared to uncoated fabrics, but does not compromise the flexibility of the fabric, since it does not make it heavy and stiff like other coatings known in the art.

[0013] As seen in Figure 4, the gas generator 1 for the airbag module of the invention comprises a housing 20 made of cuzinal and filled with a gas generating composition. Cuzinal is a copper-zinc alloy that maintains a good structural resistance at high temperatures, when compared to stainless steel and aluminium. This reduces the risk of fracture of the housing 20. An igniter 21 comprising zirconium and potassium perchlorate is located inside the housing 20 with the gas generating composition (not shown). Upon ignition the gas generating composition turns into gas and is expelled out of the housing and into the fabric cushion 2 through the outlets 22. The igniter 21 is activated by induction through a magnetic field from outside the generator 1 and is not electrically connected to the outside of the generator 1. These igniters are more reliable, because they are less exposed to moisture from the outside and cannot be set off by static discharge as in the case of other types of electrical igniters.



[0014] The gas generating composition used comprises guanidine nitrate and ammonium perchlorate. Within the same amount of time, this combination produces a larger amount of gas than other combinations. The composition may additionally comprise sodium nitrate, which results in the generated gas also having a lower temperature. Gas having a high temperature should be avoided since it might heat the fabric and burn the occupant.

[0015] Like most compositions, the composition with sodium nitrate produces a flame. As an alternative to sodium nitrate, potassium sulphate can be added to the composition. The composition with potassium sulphate not only produces large amounts of gas, but also prevents the formation of flames during the gas generating reaction so that the fabric of the cushion does not catch fire.

[0016] The weight ratio of guanidine nitrate to ammonium perchlorate determines the speed at which gas is generated. The fastest gas generating levels were obtained with weight ratios between 2:1 and 5:1. The amount of sodium nitrate or potassium sulphate does not change the speed at which the reaction occurs.

[0017] Moreover, it was observed that a weight ratio of 3:1 produced the cleanest combustion and created the smallest amount of toxic residual gas.



Claims:

1. An airbag module for protecting a vehicle occupant in a frontal collision comprising:
5 - a control unit;
 - a gas generator (1) comprising a housing (20) made of cuzinal; and
 - a fabric cushion (2) comprising a pressure regulating valve (3).

2. An airbag module according to claim 1 wherein the valve (3) comprises:
10 an elastic membrane (10) at least partially covering a vent-hole (5) provided in
 the fabric cushion (2), the membrane (10) being attached to the cushion (2) by
 means of a rubber-based adhesive (9).

3. An airbag module according to claim 1, wherein the fabric cushion (2) is made
15 of polyester and is coated with a polyamide resin.

4. A gas generator (1) for an airbag module comprising:
 - a housing (20) made of cuzinal and having outlets (22);
 - an inductively-activated igniter (21) comprising zirconium and
20 potassium perchlorate; and
 - a gas generating composition inside the housing (20), the composition
 comprising guanidine nitrate, ammonium perchlorate, and either
 sodium nitrate or potassium sulphate.

- 25 5. A gas generator according to claim 4, wherein the composition comprises a
 weight ratio of guanidine nitrate to ammonium perchlorate of 3:1.



Figure 1

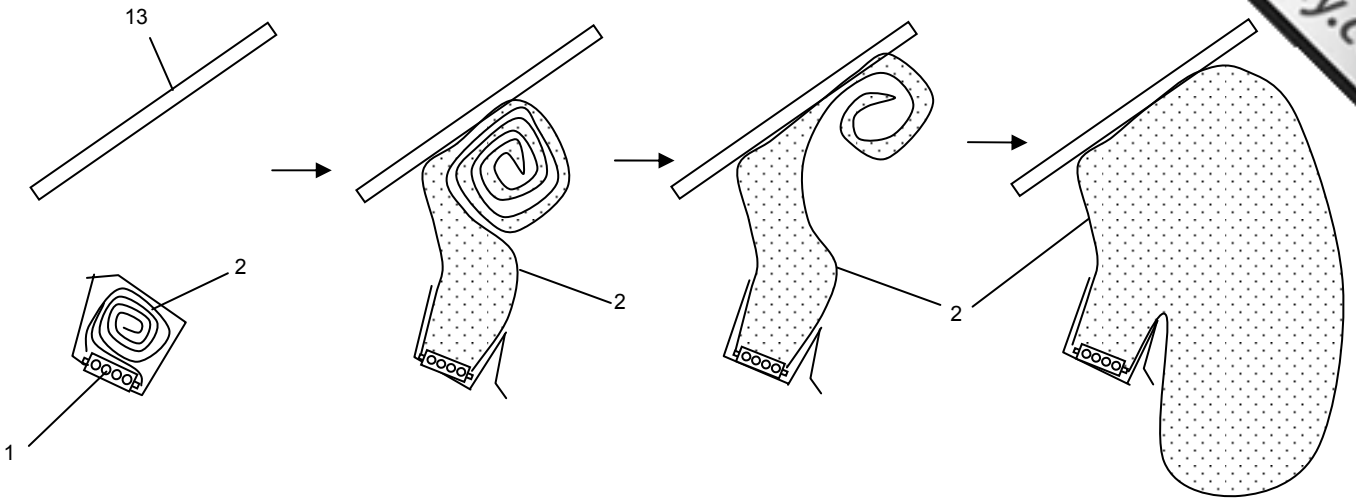

Figure 2

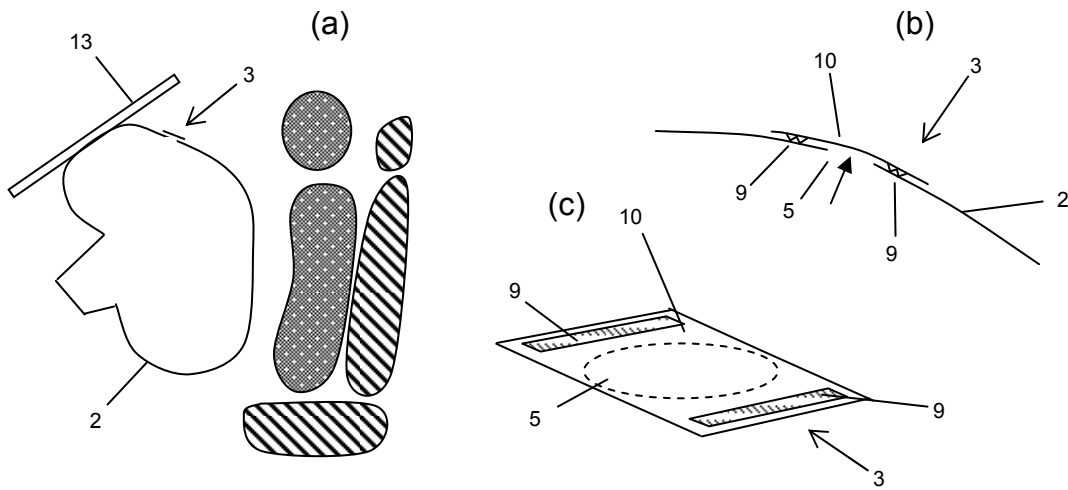

Figure 3

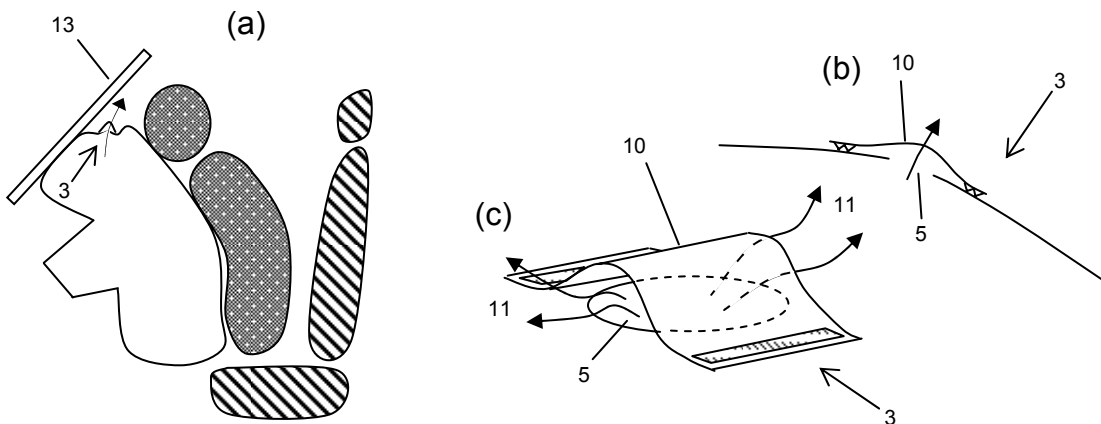
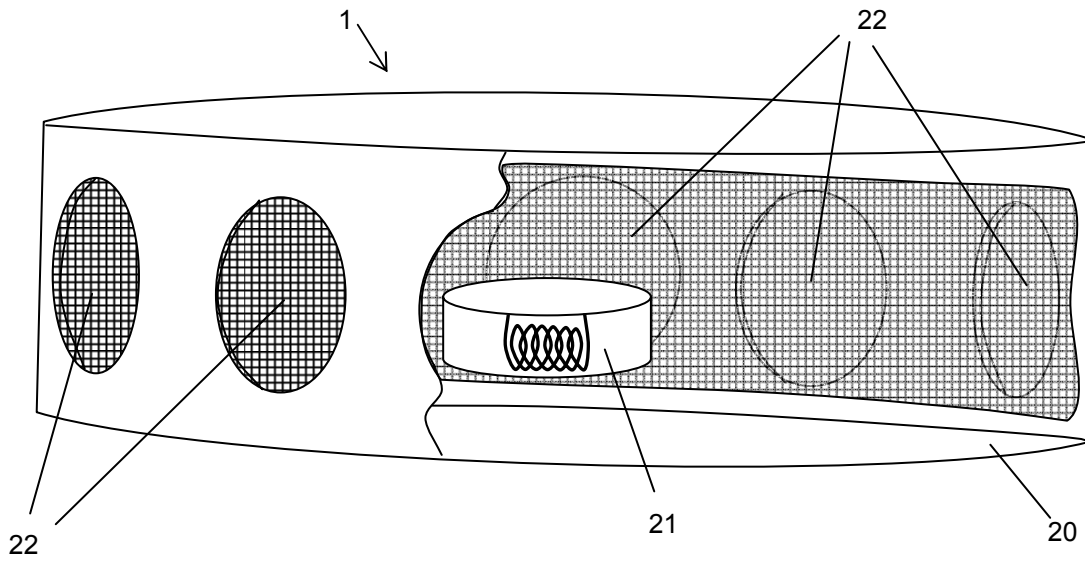

Figure 4



Magazine "Automotive Safety"; Kurtis Kraft Publications, 46222 Indiana, USA
Ed. 2/1997

"Pyrotechnical gas generating systems"

Authors: J. Unser and J. Siffert

5

[0001] Passive restraint systems such as airbags and seatbelts make use of gas generating means to activate their security systems. Pyrotechnical systems, which rapidly create large quantities of gas, have had great success.

10

[0002] Pyrotechnical systems usually comprise a gas generator housing, which can be made as a die cast container of stainless steel, nickel-plated steel, carbon steel, aluminium or cuzinal, which is a copper-zinc alloy. The container may comprise exhaust openings to channel the gas into another component of the restraint system, such as an inflatable polyester cushion bag or a cylinder-piston system.

15

[0003] Surprisingly, cuzinal maintains an almost constant resistance to breaking even at high temperatures (above 200°C). In contrast, the resistance of steel and aluminium alloys decreases progressively above 200°C.

20

[0004] The container contains a powder composition for generating gas, and an initiator. The powder composition can be ignited by the initiator. The initiator comprises a coil and highly combustible material (for example, zirconium and potassium perchlorate), that may be lit by an induced current in the coil to initiate the ignition of the powder composition. These initiators have the advantage that they are placed inside the
25 container and activated at a distance without being wired to the outside. The isolation from the outside protects the initiator from humidity, and the absence of an electrical connection removes the danger of static electricity discharges or short circuits which could accidentally trigger the initiator.



[0005] The choice of the materials which form the powder composition is of major importance. A large amount of gas has to be generated within a few milliseconds. Moreover, this gas should not be toxic since it is going to be released into the passenger compartment. When used to inflate airbags the generated gas should also not be too hot. Airbags are made of fabric which may be damaged by high temperatures. Also, if the heat is passed to the vehicle occupant when coming into contact with the airbag, it could cause burn injuries.

[0006] Powder compositions comprising a fuel agent, an oxidizer to accelerate combustion and at least one additive are considered the most effective.

[0007] The following substances have been found to give the best results:

Fuel agent	Oxidizer	Additives
cellulose	potassium chlorate	magnesium carbonate
starch	potassium perchlorate	zinc carbonate
sucrose	sodium chlorate	potassium bicarbonate
cellulose acetate	sodium perchlorate	sodium nitrate
guanidine nitrate	lithium nitrate	barium carbonate
nitroguanidine	lithium perchlorate	potassium nitrate
	ammonium perchlorate	lithium carbonate
		potassium sulphate



[0008] When there is a flame generated during the combustion process, the flame ensures that no residual glowing particles of powder composition are left and that the powder composition is completely converted into gas as quickly as possible. When the flame-producing powder compositions are used in airbag systems, airbag cushions
5 made of polyester are usually coated with nylon resin, which ensures good heat resistance to avoid problems with the flame produced. Nylon-coated polyester also maintains a high degree of flexibility, so that the time needed for deploying the airbag cushion is not adversely affected. This is crucial in airbags having a large volume or placed close to the passenger such as in the dashboard.



	(19)	European Patent Office	
	(12)	European Patent Application	
	(21)	Application number:	93 249 563
	(11)	Publication number:	EP 112233 A1
5	(22)	Date of filing:	16.11.1993
	(30)	Priority:	17.11.1992 DE 42 44 555
	(43)	Date of publication of application:	08.06.1994
	(51)	Int. Cl.:	B60R21/16
	(84)	Designated Contracting States:	BE DE ES FR GB IT NL SE
10	(71)	Applicant:	Mitter AG
	(72)	Inventor:	J. Rindt
	(74)	Representative:	W. von Trips

Steering wheel airbags

15

[0001] Various types of impact protection systems are common in the art to protect a vehicle occupant. Airbags are commonly mounted in the steering wheel and dashboard to protect the driver and a front seat passenger.

20

[0002] This invention concerns steering wheel airbags. These are relatively small airbags that are installed in steering wheels to protect the driver during frontal collision.

25

[0003] As shown in Figures 1 and 2, the invention concerns an airbag unit mounted in a steering wheel 1 comprising a pyrotechnical gas generator activated by a command unit to quickly supply gas to a nylon cushion. The generator is made of aluminium or die-cast steel. The cushion comprises two equal-sized round sheets 2a and 2b of a non-stretchable nylon fabric sewn together around their edges (represented by a dotted line in the Figures) that form an air-tight chamber for the supplied gas. The fabric sheet 2a facing the steering wheel 1 is attached to the generator to let the gas from the generator

30 flow in.



[0004] The cushion is tucked inside the steering wheel after having been folded. The cushion is firstly folded like an accordion, i.e. it is divided in equally sized sections, which are folded together back and forth. Subsequently the side portions are folded together in order to fit in the middle of the steering wheel, where the airbag module is mounted.

5 When the airbag is deployed, it expands away from the steering wheel towards the driver.

[0005] The cushion has a synthetic rubber (e.g. silicone) membrane 3 with a small vent-hole 4 that usually allows only a very limited amount of gas to be vented, as can be seen in Figure 1. When the driver hits the cushion, the pressure inside the cushion will rise. If the driver hits the cushion with excessive force, the additional pressure will trigger deformation of the elastic rubber membrane 3 (see Figure 2) so that it protrudes outwardly from the cushion, thereby enlarging the diameter of the hole 4 and allowing more gas to be vented.

15 **[0006]** This increased gas venting creates a temporary pressure drop that makes the cushion less hard. The rubber membrane 3 is attached over an opening 5 in the cushion, by means of a silicone-based adhesive, which creates an air-tight bond between the rubber and the fabric. Silicone adhesives adhere well to nylon fabrics.

20 Polyester fabrics such as PET, on the other hand, would require a resin coating if used with silicone adhesives. Such coatings would make the fabric stiffer and more bulky, hence more difficult to fold and place inside limited spaces.

Claim:

25 Airbag for a steering wheel comprising a gas generator to supply gas to a fabric cushion, the fabric cushion having an outlet valve.



Figure 1

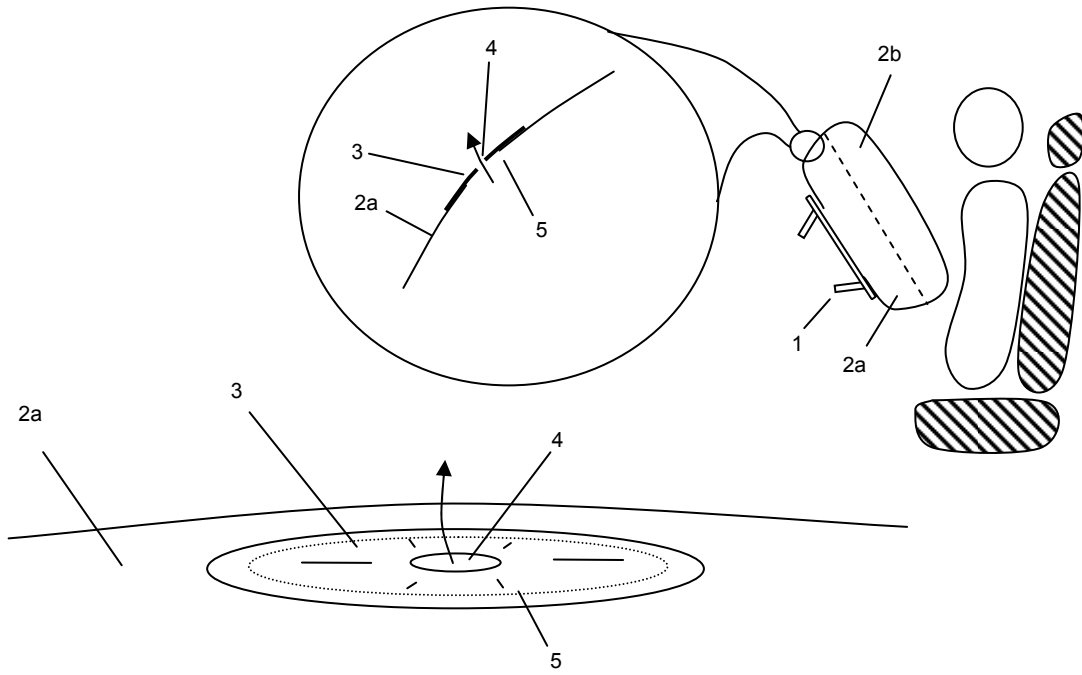
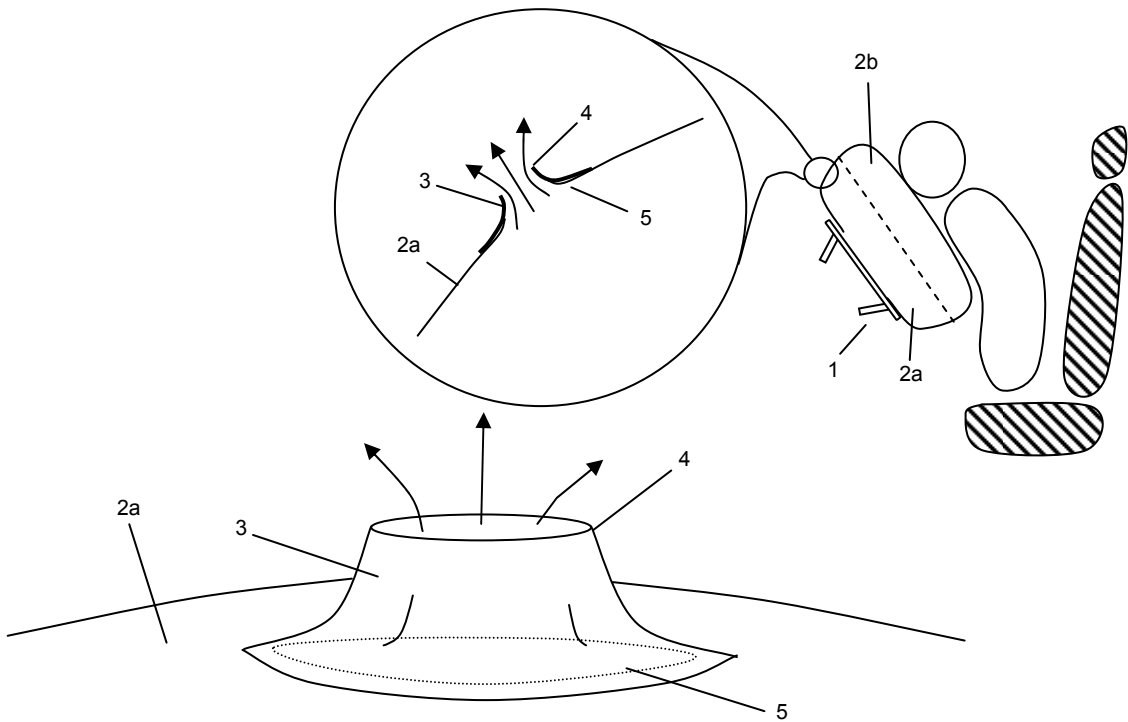

Figure 2



	(19)	French Republic, National Institute for Industrial Property, Paris	
	(11)	Publication number:	1 212 121
	(21)	Application number:	01 09090
	(51)	Int. Cl.:	B60R21/16
5	(12)	Patent Application A1	
	(22)	Filing Date:	25.07.2001
	(43)	Date of publication of the application:	31.01.2003
	(71)	Applicant:	Société Gordini
	(72)	Inventors:	J. Schlessner, F. Cevert, et P. Depailler
10	(74)	Representative:	Cabinet Behra

Improvements in vehicle occupant restraint systems

15 **[0001]** The present invention relates to safety improvements for vehicle occupant restraint systems that protect the occupants involved in frontal impact vehicle crash situations.

20 **[0002]** During a frontal impact, the vehicle decelerates suddenly, while the occupant tends to continue moving due to inertia. Systems to counter this effect, such as seat-belts and airbags, are already known in the art. In order to avoid injury, the occupant should not be stopped too abruptly. At the same time, the restraint system must be deployed swiftly.

25 **[0003]** Seat-belt systems usually include a belt made of a polyamide such as nylon, a seat-belt tensioner comprising a cylinder-piston assembly and a seat-belt buckle rigidly connected to the piston. The system is triggered in emergency situations and pulls the seat-belt very rapidly to hold the occupant firmly in position. The cylinder-piston assembly is usually activated by releasing pressurized gas into the piston chamber. The
30 gas has to be stored under a very high pressure in a gas container for the restraint system to react quickly and effectively. However, this may create a safety problem in case of rupture of the gas container.



[0004] The present invention overcomes this drawback by providing an occupant restraint system that comprises a pyrotechnical charge and an igniter to supply gas in a safe way.

5 **[0005]** Figures 1 and 2 show a safety system according to the invention before and after deployment (front and sideview).

[0006] The safety system includes a seat-belt tensioner and an airbag module comprising a curtain airbag 5.

10

[0007] The seat-belt tensioner comprises a cylinder-piston assembly 1, a buckle 2, a pyrotechnical charge 3 and an igniter 4. The charge 3 and the igniter 4 are placed inside the cylinder chamber 1b. By igniting the pyrotechnical charge 3, a greater quantity of gas can be created almost instantly and the cylinder-piston assembly 1 may be activated
15 faster than by releasing pressurized gas.

[0008] When these assemblies are provided close to seat cushions, a pyrotechnical charge composed of guanidine nitrate, ammonium perchlorate and sodium nitrate is advantageous. Such a charge produces large quantities of gas per unit of reactant within
20 the first milliseconds of reaction. Although a flame is still produced, the generated gas has a lower temperature, because the sodium nitrate works as a catalyst and a coolant. This is important, because the cylinder-piston assembly is usually built into or close to a seat covered with a fabric such as polyester, and so the generated gas will not heat the seat cover and cause further discomfort to the occupant.



5 **[0009]** In principle, all pyrotechnical charges comprising a fuel agent and an oxidizer produce a flame. If a flame is undesirable, potassium sulphate may be used instead of sodium nitrate in the charge. The resulting charge does not create a flame but still produces large quantities of gas. However the use of potassium sulphate does not have an effect on the temperature of the generated gas. In this case, the pyrotechnical charge is not completely consumed and some residual glowing particles are left. Nevertheless, due to the absence of a flame, the overall risk of igniting the fabric of the seat, is still significantly reduced, even in the event that the assembly ruptures in a severe crash.

10 **[0010]** The use of a composition of 72% by weight guanidine nitrate, 24% by weight ammonium perchlorate and 4% by weight sodium nitrate can be advantageous, since it produces the most gas per unit of composition used.

15 **[0011]** Other occupant restraint systems, such as airbags, which are also susceptible to rupture, may also benefit from using such compositions, because an airbag requires a large quantity of gas to be produced very rapidly. Care also has to be taken when choosing the material of the igniter, because some materials, such as azides, react with compositions based on guanidine nitrate to produce extremely toxic gases and may not be used in rupture-sensitive systems.

20

Claim:

Vehicle occupant restraint system comprising a gas source, characterized in that the gas source comprises a pyrotechnical powder and an igniter.



Figure 1

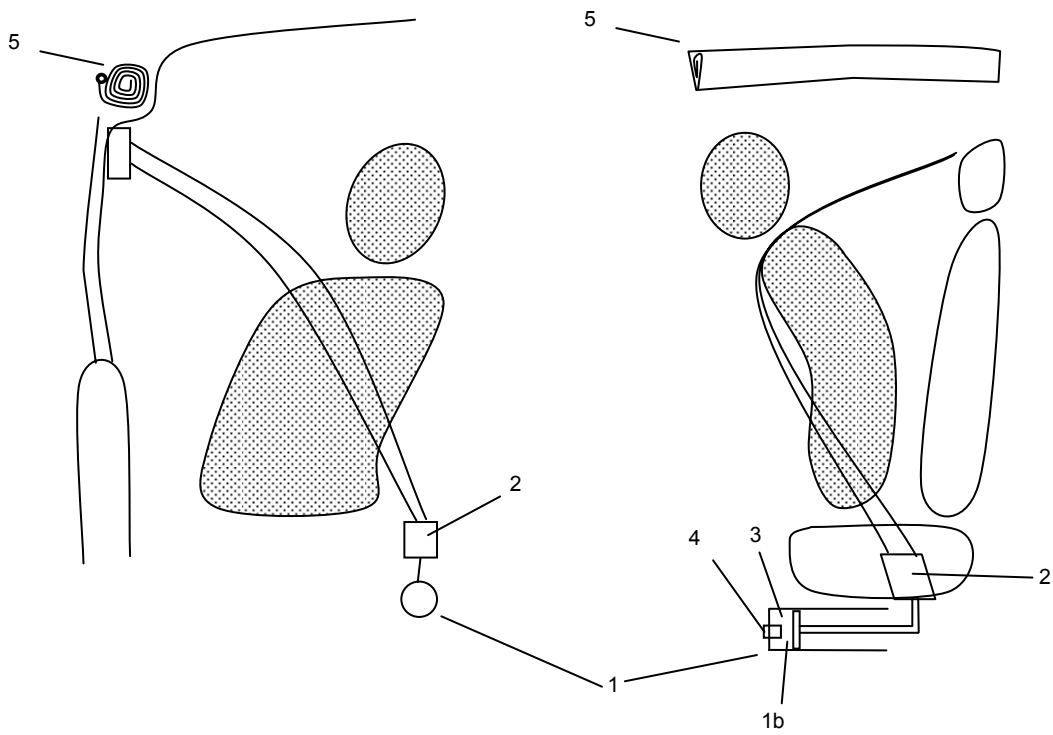
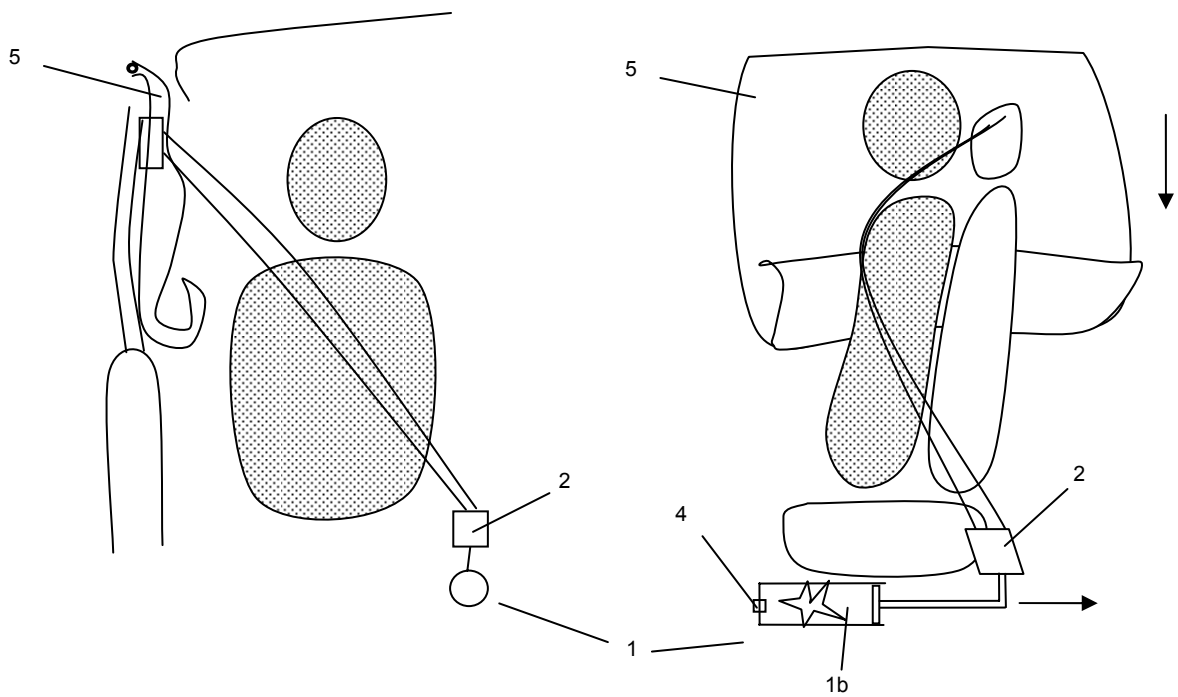

Figure 2



	(19) United States Patent	
	(11) Publication number:	2,222,421 B1
	(22) Date of filing:	23.07.1998
	(45) Publication Date:	03.04.2001
5	(51) Int. Cl.:	B60R21/239
	(52) US Cl.:	280/742
	(73) Assignee:	BRM Corp.
	(75) Inventors:	G. Villeneuve, Richelieu (CA)
		B. Vukovich, Fresno (US)
10		R. Peterson, Almby (SE)

Airbag module to be mounted in a dashboard

15 **[0001]** The present invention relates to an inflatable airbag to be mounted in the dashboard of a vehicle. Such airbags are intended to protect the passenger during head-on collisions. According to the passenger's size and position, it is advantageous to fill the airbag with different amounts of gas in order to achieve different pressures.

20 **[0002]** The purpose of the invention is to provide a system to control the internal pressure of an airbag and adapt it to each passenger and situation in a simple manner, and hence to safeguard the passenger in impact situations.

25 **[0003]** Figure 1 shows the airbag module of the present invention comprising a deployed fabric airbag 10 and a gas generator 2. The generator 2 comprises a housing that is made of any suitable metal for die-cast containers referred to in the article "Pyrotechnical gas generating systems" of the magazine "Automotive Safety", ed. 2/1997.



[0004] When a safety processing unit 1 in the vehicle senses that impact has occurred or is imminent, it sends an electric pulse through a cable connected to an electric match 3 to activate the latter. The electric match 3 is an electrical conductor wrapped in lead azide, which is a highly combustible, fast reacting material. The
5 activation of the electric match 3 ignites a gas-generating composition which is inside the generator 2, thus producing large quantities of gas that will be channelled into a restraint system to be activated.

[0005] The fabric bag 10 is made of a non-stretchable PET material and provided
10 with a vent-hole 11 in the fabric. The vent-hole 11 is covered with a ribbon 12 made of the same fabric as the bag 10. As seen in Figure 1, the ribbon 12 is stitched to the fabric bag 10 on two opposed edges. The ribbon 12 has a loop 13 of excess fabric stitched to form a tearable seam 14 close to one of the edges such that the vent-hole is covered by a portion of the ribbon in an air-tight manner.

15
[0006] During impact a pressure spike is created inside the bag 10, thus generating a force towards the outside on the non-stretchable ribbon 12 through vent-hole 11. As shown in Figure 2, if this force exceeds a certain value, the tearable seam 14 will tear and the excess fabric of the loop will be released, thereby creating an arch and
20 uncovering the vent-hole 11. Gas is then expelled, thus relieving the pressure and making the airbag less hard.

[0007] The generator 2 needs to generate enough gas to fill a large frontal airbag to the required pressure. Large volumes of gas are therefore necessary. Pyrotechnical
25 powder compositions are preferred because they generate the maximum quantity of gas per volume of ingredients.



[0008] In order to avoid any small glowing particles of non-consumed pyrotechnic powder rupturing the airbag 10 or the ribbon 12, a mesh is placed at the gas outlets of the gas generator 2 to trap the particles, but allowing the generated gas to flow into the airbag 10. If necessary, this mesh may also contain the combustion flame inside the generator 2 to prevent the fabric from igniting.

5

[0009] The ribbon 12 also has the purpose of diverting the gas to the sides. The generated gas may reach a very high temperature and may injure the occupant. Therefore, care has to be taken when choosing the location of the vent-hole 11.

10

Claim:

An occupant restraint system to be mounted in the dashboard of a vehicle, comprising a gas generator and an inflatable airbag, said airbag comprising a vent-hole and a ribbon over said vent-hole defining an outlet flow path for the gas exiting through the vent-hole.

15



Figure 1

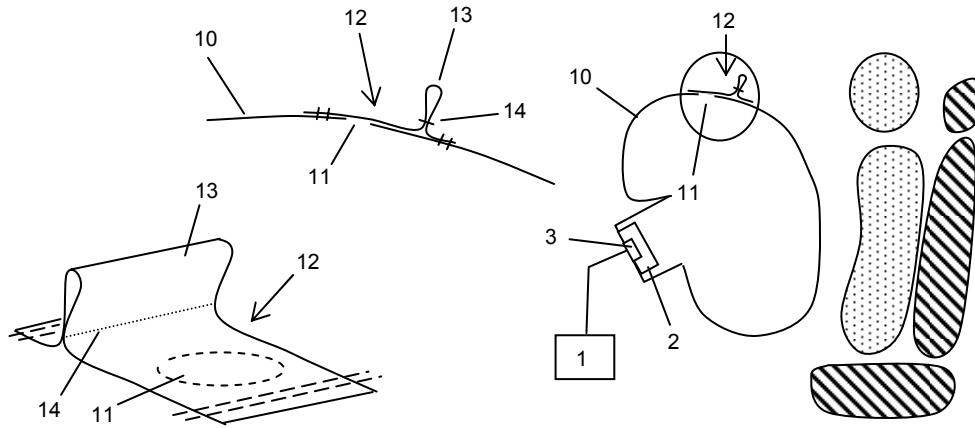
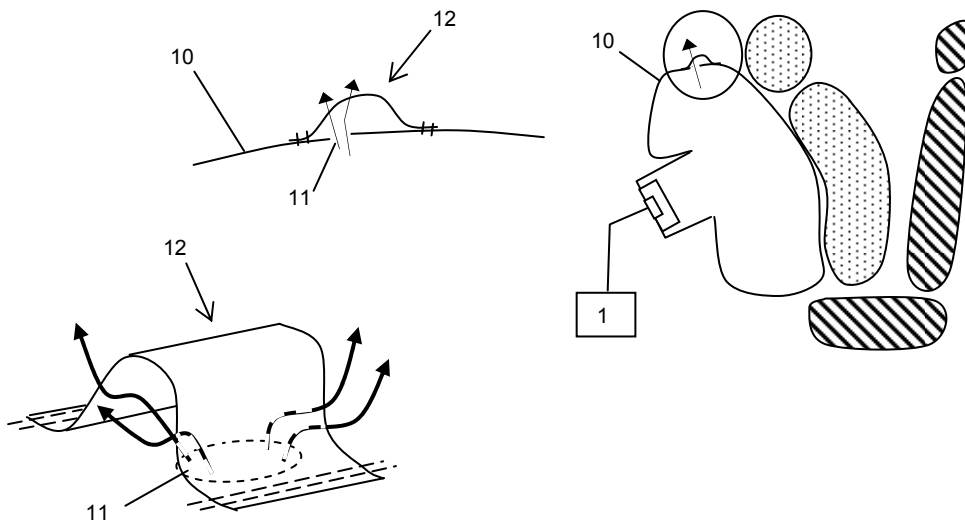
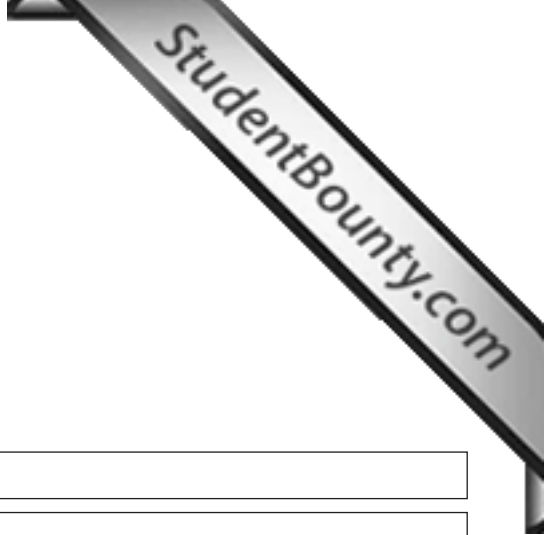

Figure 2





Notice of opposition to a European patent

I. Patent opposed

Patent No.

Application No.

Date of mention of the grant in the European Patent Bulletin (Art. 97(3), Art. 99(1) EPC)

Title of the invention

II. Proprietor of the patent

first named in the patent specification

Opponent's or representative's reference (max. 15 keystrokes)

III. Opponent

Name

Address

State of residence or of principal place of business

Nationality

Telephone/Fax

Multiple opponents (see additional sheet)

IV. Authorisation

1. Representative

(name only one representative or name of association of representatives to whom notification is to be made)

Address of place of business

Telephone/Fax

Additional representative(s) on additional sheet/see authorisation

2. Name(s) of employee(s) of the opponent authorised to act in these opposition proceedings under Art. 133(3) EPC

Authorisation(s) to 1./2. not considered necessary

has/have been registered under No.

is/are enclosed

V. Opposition is filed against

• the patent as a whole

• claim(s) No(s).

VI. Grounds for opposition:

Opposition is based on the following grounds:

(a) the subject-matter of the European patent opposed is not patentable (Art. 100(a) EPC) because:

• it is not new (Art. 52(1); Art. 54 EPC)

• it does not involve an inventive step (Art. 52(1); Art. 56 EPC)

• patentability is excluded on other grounds, i.e. Article

Art.

(b) the patent opposed does not disclose the invention in a manner sufficiently clear and complete for it to be carried out by a person skilled in the art (Art. 100(b) EPC; see Art. 83 EPC).

(c) the subject-matter of the patent opposed extends beyond the content of the application/of the earlier application as filed (Art. 100(c) EPC, see Art. 123(2) EPC).

VII. Facts (Rule 76(2)(c) EPC)

presented in support of the opposition are submitted herewith on a separate sheet (annex 1)

VIII. Other requests:

IX. Evidence presented

Evidence is enclosed
will be filed at a later date

A. Publications:

1
Particular relevance (page, column, line, fig.):

2
Particular relevance (page, column, line, fig.):

3
Particular relevance (page, column, line, fig.):

4
Particular relevance (page, column, line, fig.):

5
Particular relevance (page, column, line, fig.):

6
Particular relevance (page, column, line, fig.):

Continued on additional sheet

B. Other evidence

Continued on additional sheet

Please do not use

X. Payment of the opposition fee is made

- as indicated in the enclosed voucher for payment of fees and costs (EPO Form 1010)
- via EPO Online Services

XI. List of documents

Enclosure No.

- 0 Form for notice of opposition
- 1 Facts (see VII.)
- 2 Copies of documents presented as evidence (see IX.)
 - a Publications
 - b Other documents
- 3 Signed authorisation(s) (see IV.)
- 4 Voucher for payment of fees and costs (see X.)
- 5 Additional sheet(s)
- 6 Other

Number of sheets

Please specify here:

XII. Signature of opponent or representative

Place

Date

Signature

Name (block capitals)

In case of legal persons, signatory's position within company