

## EUROPEAN QUALIFYING EXAMINATION 2011

# Paper C

This paper comprises:

- \* Letter from opponent to professional representative 2011/C/EN/1-2
- \* Annex 1 2011/C/EN/3-10
- \* Annex 2 2011/C/EN/11-12
- \* Annex 3 2011/C/EN/13-17
- \* Annex 4 2011/C/EN/18-19
- \* Annex 5 2011/C/EN/20-24
- \* Annex 6 2011/C/EN/25
- \* Notes to the notice of opposition (EPO Form 2300),  
Form 2300: Notice of opposition to a European patent

D. J. Tenorio  
Radiadores Zorrilla, S.  
C/ Luis Mejía, 11  
01844 Seville  
SPAIN

Dr. Inés de Ulloa  
European Patent Attorney  
C/ Convento, 22  
01545 Seville  
SPAIN

Seville, 3.3.2011

Dear Dr. de Ulloa,

Please file an opposition against European patent 2 698 132 (Annex 1) in the name of our company. We have obtained Annexes 2 to 6, which may be useful.

File inspection has revealed that the application was originally filed in Spanish and then translated into English. We have verified that the original application filed in Spanish is identical to the priority application.

During examination, the applicant requested that the word "magnesium", which was used in the English translation, be replaced by the word "manganese" since the original text in Spanish referred only to "manganese". Can we use this information to attack the patent?

Furthermore, we have discovered that claim 6 of the patent was added during examination.

We noted that the last paragraph of the description in Annex 5 was not included in its priority document. In addition, the abstract in Annex 5 mentions that "the tubes may be coated externally with an aluminium zinc alloy in order to protect them against corrosion" and that "using an aluminium zinc alloy providing from 1 g/m<sup>2</sup> to 4 g/m<sup>2</sup>, preferably 2 g/m<sup>2</sup>, of zinc has given the best results". Are these facts of use?

In order to reduce the costs for our company, we would like any oral proceedings to be held as a video-conference. Is this possible?

Yours sincerely,

D. J. Tenorio  
(Director)

Enclosures:

Annex 1: EP 2698132 B1

Annex 2 : *Alloy Technology Review*, No. 8/96, published 30 August 1996

Annex 3: US 3 245 678

Annex 4: GB 2 190 800 A

Annex 5: WO 2008/004308 A2

Annex 6: *Automobile Technology Today*, 39 (1970), May, No. 1, page 4

(19)  **Europäisches Patentamt  
European Patent Office  
Office européen des brevets**

(11) **EP 2698**

(12) **EUROPEAN PATENT SPECIFICATION**

(45) Date of publication and mention  
of the grant of the patent:

**03.06.2010**

(51) Int. Cl.<sup>7</sup>: **F28F1/12D,  
B23K35/00,  
B21D53/08**

(21) Application number: **08000322.9**

(22) Date of filing: **08.02.2008**

(54) **Brazed heat exchanger**

Gelöteter Wärmetauscher

Echangeur de chaleur brasé

(84) Designated Contracting States:

**DE ES FR GR GB**

(30) Priority:

**09.02.2007 ES200700030**

(43) Date of publication of application:

**14.08.2008**

(73) Proprietor:

**Industrias Clarín, SA**

(72) Inventor:

**Fermín de Pas  
C/ Alvaro Mesía, 4  
01884 Vetusta (ES)**

(74) Representative:

**Ozores, Ana  
Victor Quintanar  
01885 Oviedo (ES)**

Note: Within nine months from the publication of the mention of the grant of the European patent, any person may give notice to the European Patent Office of opposition to the European patent granted. Notice of opposition shall be filed in a written reasoned statement. It shall not be deemed to have been filed until the opposition fee has been paid (Art. 99(1) European Patent Convention).

**[0001]** The present invention relates to a fin, a process for manufacturing a fin, exchanger and a tube for the heat exchanger.

5 **[0002]** A tube heat exchanger, such as a radiator mounted on a combustion engine vehicle, or a condenser or an evaporator of an air conditioner, is provided with fins disposed on the tubes to efficiently perform the heat exchange function. It is an established method to provide the fins, the tubes and the tanks made of a metal, in particular aluminium (a term which in the art also includes aluminium alloys), and to join them by brazing. The known method has nevertheless the disadvantage that the brazing  
10 process has to be performed in a vacuum, since otherwise an oxide layer would form over the surface of the components to be brazed. Such an oxide layer compromises the quality of the joint. Moreover, achieving vacuum conditions always involves very high costs.

15 **[0003]** The problem addressed by the present invention is to overcome these disadvantages.

**[0004]** This is achieved by the features cited in the claims. Due to the provision of a flux, i.e. a chemical agent, the oxidation of the metal during brazing is avoided. This has  
20 the advantage that brazing can be performed under atmospheric conditions.

**[0005]** The invention will now be described with reference to the accompanying figures 1, 2 and 3.

25 **[0006]** Figure 1 shows a heat exchanger. The heat exchanger is provided with two tanks 10 and tubes 11 for the flow of a first fluid (liquid or gas), for example oil, extending between the tanks. The first fluid enters and leaves the tubes through the tanks. Corrugated fins 12, i.e. fins having parallel ridges and valleys, disposed between the tubes provide channels for the flow of a second fluid, for example air, increasing the  
30 heat exchange surface area. The first and the second fluids exchange heat during their passage through the heat exchanger.

[0007] Figure 2 is an enlarged view of a detail of the heat exchanger of figure 1. It is brazed. The fins 12 are covered with a flux 14. The tubes 11 are pre-coated with aluminium zinc alloy 15, so that in applications in which the second fluid is very corrosive, the formation of holes by corrosion is avoided. A brazing alloy 13 and the flux 14 are applied to the pre-coated tubes and the tanks to be joined to the tubes. Since the aluminium zinc alloy 15 is more prone to corrosion than the aluminium alloy forming the inner part 16 of the tube, corrosion would first affect the aluminium zinc alloy coating, and not the inner part 16 of the tube. The best results have been obtained when the aluminium zinc alloy provides from 1 g/m<sup>2</sup> to 4 g/m<sup>2</sup> of zinc.

10

[0008] Different aluminium alloys can be used for the inner part of the tube of the heat exchanger of the invention. In particular, the strength of the inner part of the tube can be improved by using an aluminium alloy containing manganese. We have found that such an alloy is suitable for brazing with a flux under atmospheric conditions.

15

[0009] The tubes used for the heat exchanger of the invention have a planar surface on which the fin is fixed, as may be seen from figure 1. This is advantageous since it facilitates the fixing of the fin. Since a planar surface provides a large area of contact between the fin and the tube, the joint between both pieces is strong and easy to achieve.

20

[0010] The heat exchanger of the invention can be used with oil as the first fluid and air as the second fluid. Nevertheless, the invention is not restricted to this particular use. For example, instead of oil, other fluids may be used as first fluid.

25

[0011] With reference to figure 3 the process for manufacturing a fin according to a particular embodiment of the invention will be explained.

**[0012]** A metal plate 21 is passed between a first pair of rollers 22 having protrusions. Due to the turning of the rollers 22, the protrusions give the plate a corrugated shape having bent portions and straight portions joining the bent portions.

5 **[0013]** Depending on the different applications, it may be required to have a corrugated plate with a particular pitch, i.e. the distance between two adjacent corrugations. This can be achieved by changing the pitch of the corrugations by passing the corrugated plate through a second pair of rollers 23. If, for example, the second pair of rollers 23 has a slower rotation speed compared to the first pair of rollers 22, the corrugations of  
10 the plate are compressed and adjacent bent portions approach each other. Thus the pitch is decreased. Changing the pitch of the corrugated plate after its formation has the advantage that a fin having a particular pitch can be obtained without having to change the first pair of rollers.

15 **[0014]** The corrugated plate is then coated with a flux. In order to apply the flux to the corrugated plate, the plate is immersed into a bath 24 containing flux and water. The plate is then dried, e.g. by introducing it into an oven 25, so that the water is removed and the flux is fixed to the surface of the plate. The plate is cut by a cutter 26 to the desired length thereby forming the fin. When such a fin is attached to the tubes of a heat  
20 exchanger, the heat exchange surface area is increased.

**Claims**

1. Process for manufacturing a fin comprising the steps of:  
passing a plate (21) between a pair of rollers (22) having protrusions thereby  
5 forming a corrugated plate;  
immersing the corrugated plate into a bath (24) containing flux and water;  
drying the corrugated plate thereby fixing the flux to its surface; and  
cutting the plate to the desired length thereby forming the fin.
- 10 2. Process according to claim 1, further comprising the step of changing the pitch of  
the corrugated plate after its formation.
3. Corrugated fin obtainable by the process of claim 1.
- 15 4. Aluminium heat exchanger comprising: two tanks (10), tubes (11) extending  
between the tanks (10) for the flow of a first fluid, corrugated fins (12) between  
the tubes (11) providing channels for the flow of a second fluid, wherein the  
tubes, the fins and the tanks have been joined by brazing with a brazing alloy (13)  
and a flux (14).
- 20 5. Heat exchanger according to claim 4 wherein the tubes (11) are pre-coated with  
an aluminium zinc alloy (15).
6. Heat exchanger according to claim 5 wherein the aluminium zinc alloy (15)  
25 provides  $2 \text{ g/m}^2$  or  $4 \text{ g/m}^2$  of zinc.
7. Heat exchanger according to claim 4 for use with oil as first fluid and air as  
second fluid.
- 30 8. Tube for a heat exchanger according to claim 4, said tube (11) having a planar  
surface and comprising an aluminium alloy including manganese.



Fig. 1

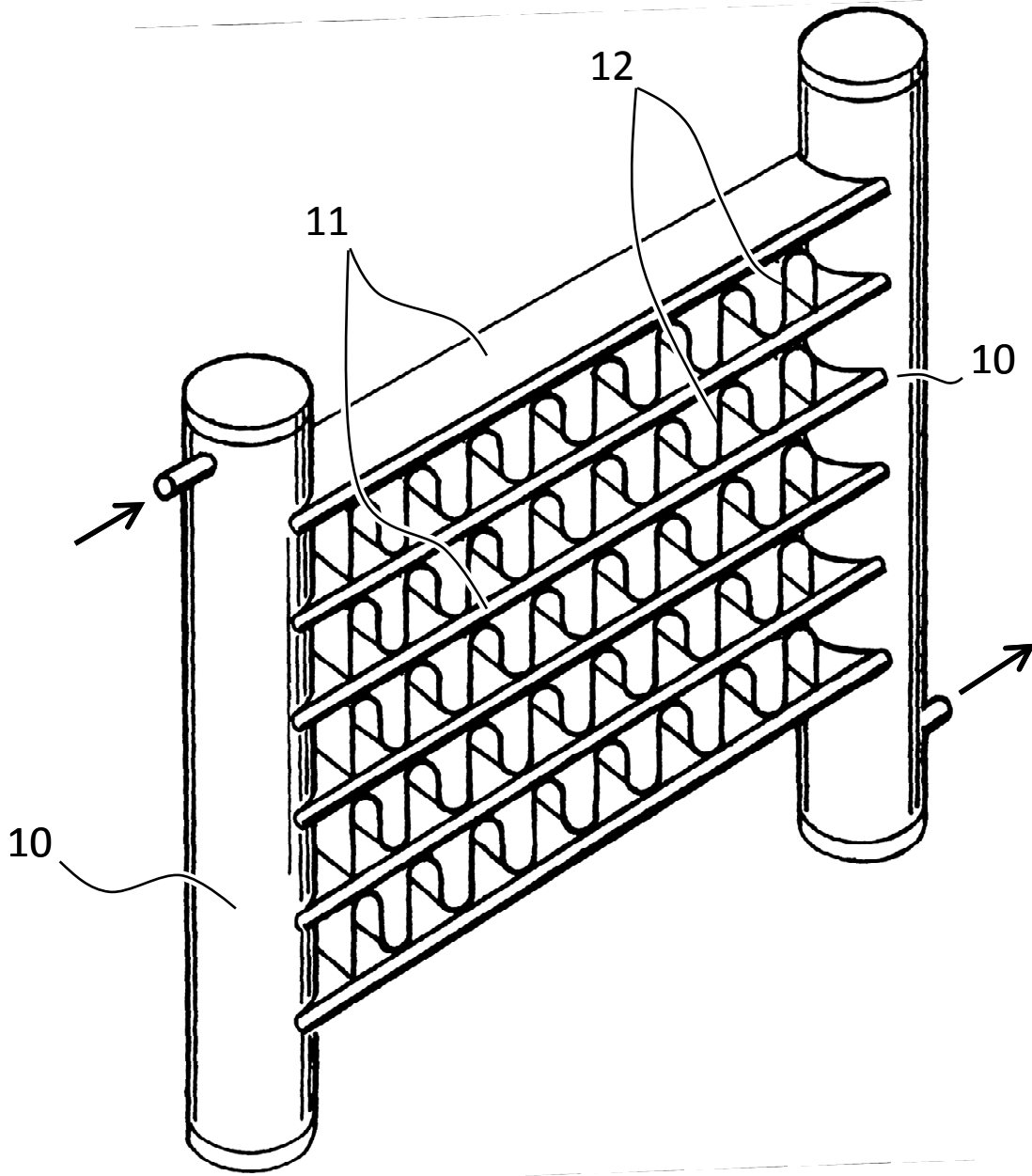

Fig. 2

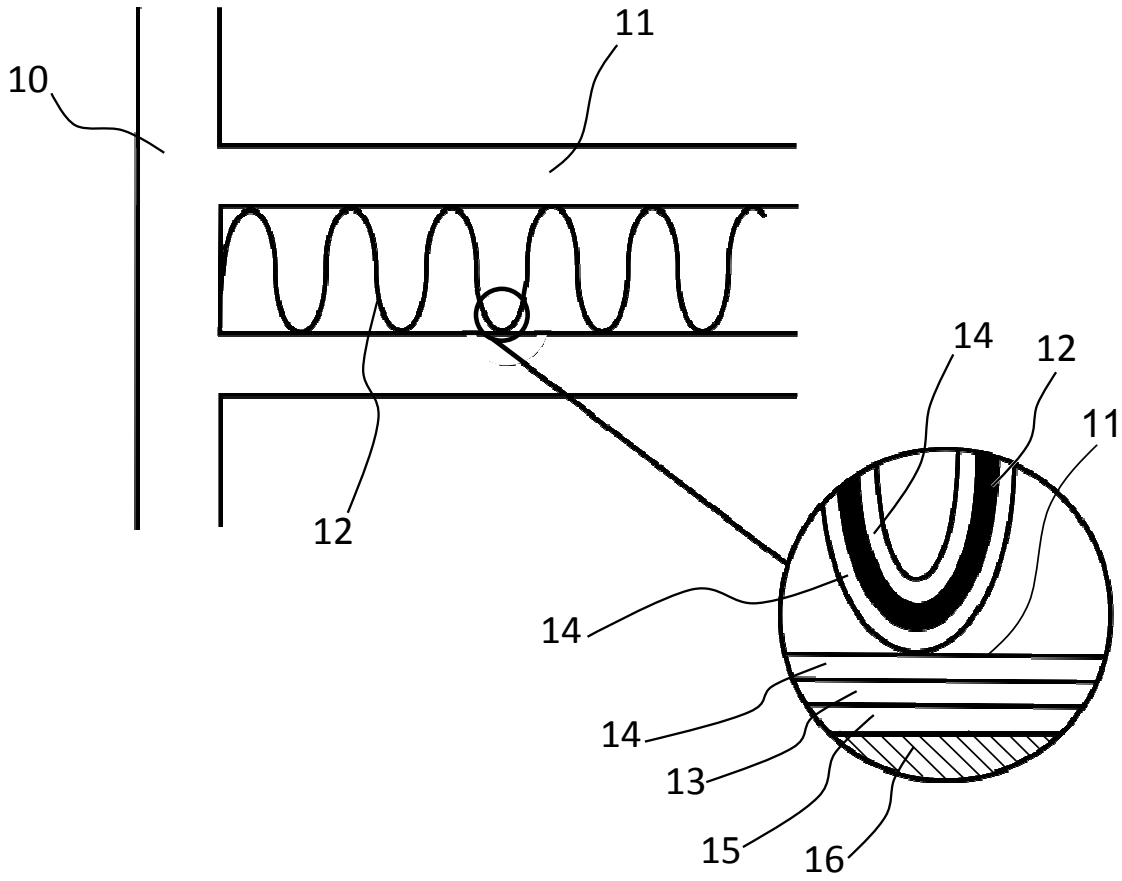
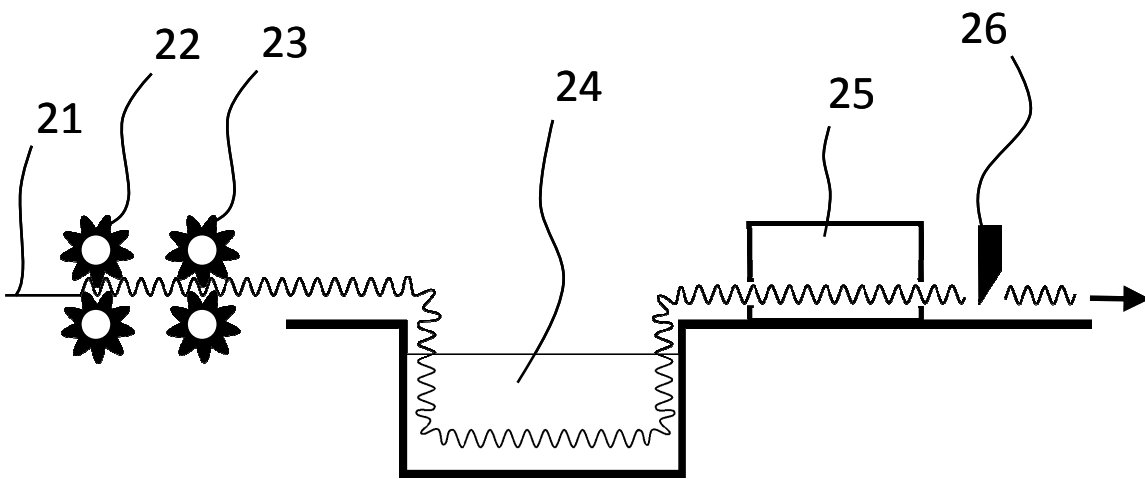

Fig. 3



**Brazing of Aluminium Alloys**

- 5 Aluminium is widely used in the industry due to its low specific weight and outstanding corrosion resistance. Aluminium parts are commonly joined by brazing, since joining by welding requires higher temperatures, which leads to deformation of the pieces to be joined.
- 10 As shown in the figure, brazing is a joining process whereby a filler metal, i.e. the brazing alloy, is applied at the joint (see step 1) and is heated to its melting temperature, for example in a furnace (see step 2). The molten filler metal interacts with the surface of the pieces to be joined. The melting temperature of the materials to be joined is higher than the melting temperature of the filler metal. Upon cooling, the joint is formed (see
- 15 step 3).

Fig. 1

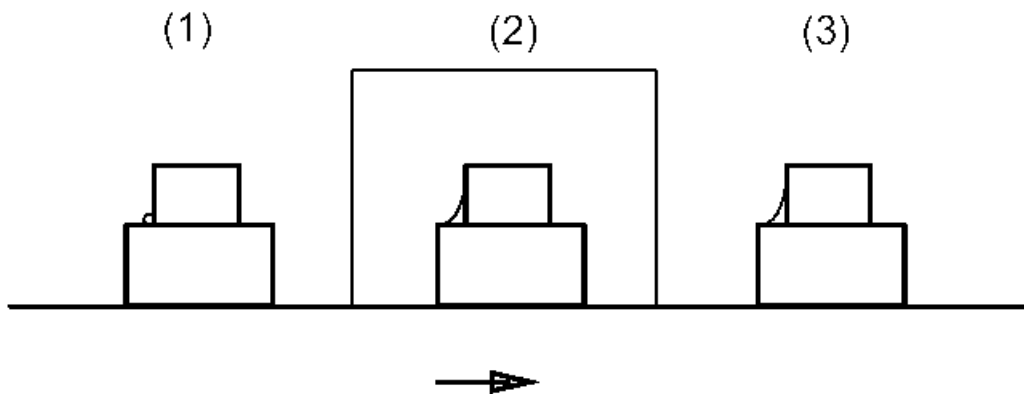

Currently aluminium parts are brazed using two different methods: brazing in a controlled atmosphere furnace and brazing within a vessel sealed under vacuum.

**(i) Controlled atmosphere brazing**

5

Controlled atmosphere brazing is performed under atmospheric pressure in a controlled atmosphere, for example, a gaseous mixture comprising mainly an inert gas, but also containing air or oxygen. Since aluminium quickly forms an oxide layer whenever oxygen is present, a flux is required. The flux prevents oxidation of the aluminium surfaces during brazing. The flux is applied to the aluminium surfaces as well as to the metal filler. Flux is typically not corrosive and does not have to be removed after brazing. Flux can be applied using different techniques, as for example dipping or spraying. Dipping is done by immersing the parts to be brazed into a bath of water and flux. Exactly the same results can be achieved by spraying an aqueous solution of flux. Both of these methods require drying in order to remove the water, so that the flux adheres. The flux can also be applied electrostatically as a dry powder, however the flux layer obtained is not as uniform as the one obtained by the previously mentioned techniques.

10

15

**(ii) Vacuum brazing**

20

The advantage of brazing under vacuum is that it is not necessary to utilise flux. Due to the vacuum conditions oxidation is prevented or reduced. Nevertheless, vacuum brazing incurs higher costs than controlled atmosphere brazing.

**United States Patent US 3 245 678**

(22) Filed:	<b>28.04.1970</b>
(45) Date of patent:	<b>04.07.1972</b>
(51) Int. Cl.:	<b>F24D19/06, B21D53/04</b>
5 (72) Inventor:	<b>F. Rojas</b>
(73) Assignee:	<b>Calisto Limited</b>

**Process of manufacture of a convection plate for a central heating radiator**

10 **[0001]** The invention relates to a process of manufacture of a convection plate for a central heating radiator.

**[0002]** A conventional central heating radiator is shown in figures 1 and 2 in which warm water is used to heat ambient air. The radiator comprises a panel 1 having headers 2 along the upper and lower edges and vertical channels 3 communicating with the headers, as illustrated in figure 1. Water enters and leaves the vertical channels 3 via the headers 2. Figure 2 shows a convection plate 4 in the form of a corrugated steel plate, which is welded to the rear of the panel 1. The corrugations of the convection plate 4 form the passages for the flow of the air. Using such a convection plate, the heat exchange efficiency of the radiator is improved by increasing the surface area with which the air to be warmed comes into contact.

**[0003]** It is known in the art that in order to achieve optimum heat exchange efficiency the convection plate has to be joined to the panel at the most outwardly protruding location of the vertical water channels, as shown in figure 2. At these locations, the vertical channels have a planar surface in order to provide a large contact area between the channels and the convection plate thereby facilitating the joining of the pieces. The use of channels having a planar surface for facilitating joining of corrugated metal plate to any kind of conduit or channel has been long known not only for central heating radiators, but also for other types of heat exchangers.

**[0004]** As shown in figure 2, to join the convection plate to the planar surface of the channels, the convection plate has to match the particular shape of the panel. Therefore it is required that the distance between two corresponding portions of adjacent corrugations of the convection plate matches the distance between the channels in the panel. Conventionally, the corrugations of the convection plate are formed using a folding machine which forms each fold of the corrugations individually. This allows the distance between two corresponding portions of adjacent corrugations to be selected as required. However, this is a time consuming process.

**[0005]** Therefore, the aim of the present invention is to speed up the production of a convection plate while still allowing the distance between two corresponding portions of adjacent corrugations to be selected as required.

**[0006]** This problem is solved by the method of claim 1.

**[0007]** The process of the invention is described by way of example with reference to figures 3 and 4.

**[0008]** A metal plate 11 is first shaped by a stamping tool 12 having teeth for forming the corrugated structure of the convection plate. Due to the teeth, a plural number of corrugations are formed in just one stamping step (figure 3). This step is then repeated as many times as required. The distance between two corresponding portions of adjacent corrugations is then reduced by compressing the corrugated plate by means of a roller (figure 4). Once the suitable distance between two corresponding portions of adjacent corrugations is achieved, the plate is released and cut to the desired length. This method has the advantage that convection plates suitable for different panels can be obtained with a single stamping tool 12, and has been found to be suitable for any type of metal plate.

**Claim:**

5 A method to produce a convection plate for a radiator comprising the steps of:  
passing a metal plate through a stamping tool having teeth thereby forming a  
corrugated plate and reducing the distance between two corresponding portions of  
adjacent corrugations by compression.



Fig. 1

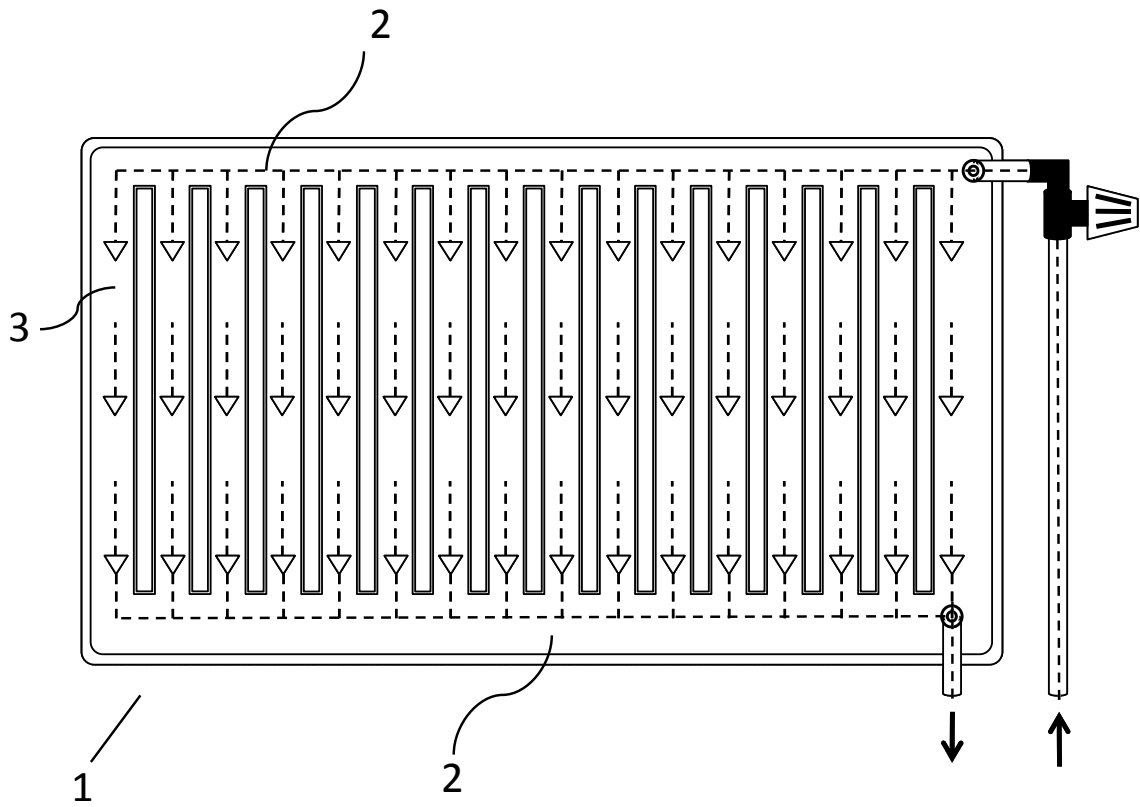

Fig. 2

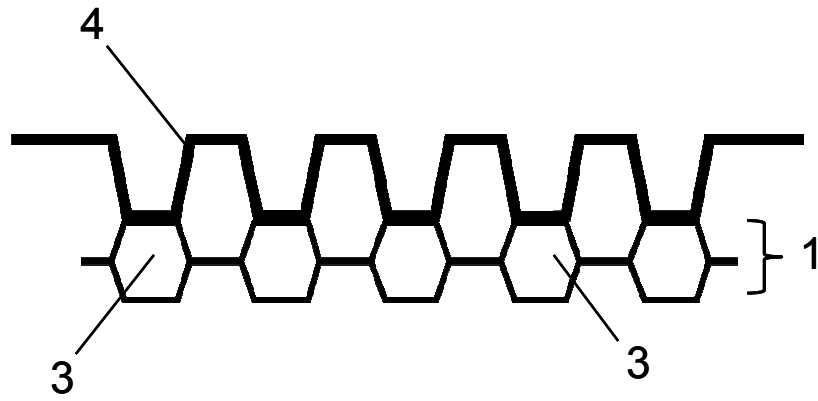

Fig. 3

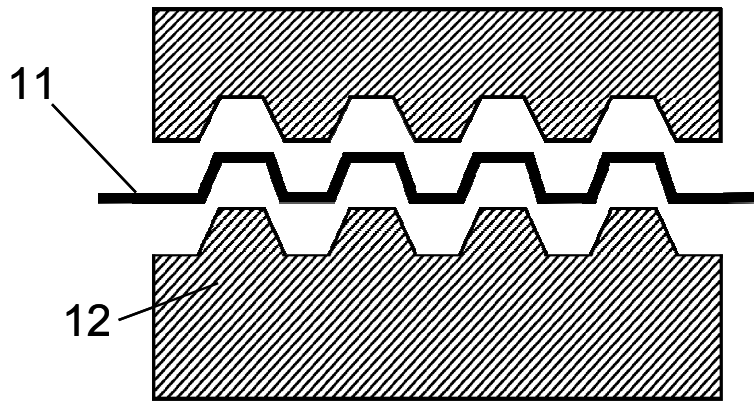

Fig. 4



**UK Patent Application GB 2 190 800 A**

(22) Date of filing: **26.02.1985**  
(43) Date of publication: **13.08.1986**  
(51) Int. Cl.: **F16L55/16**  
5 (71) Applicant: **F. G. Lorca**  
(72) Inventor: **Pineda, Mariana**

**Aluminium tube for a heat exchanger**

10 **[0001]** The present invention relates to an aluminium tube for a heat exchanger.

**[0002]** Aluminium tubes are widely used owing to their low weight. In order to meet the low weight requirements of some industries, e.g. the aeronautic industry, it is further necessary to reduce the thickness of the walls of the tubes forming the heat exchangers.  
15 However, a reduction of the wall thickness can lead to leakage of fluid flowing through the tubes due to corrosion of the aluminium.

**[0003]** The above mentioned deficiencies are overcome by the tube according to the present invention as defined in the claim.

20 **[0004]** The tube according to the present invention is made of an aluminium alloy containing manganese. Manganese has the effect of making the aluminium alloy less prone to corrosion and oxidation. Manganese is also important for improving the strength of the tube.

25 **[0005]** A tube of such an aluminium alloy can be joined by brazing to another component of the heat exchanger. For this purpose, the tube is coated with a brazing alloy. When the brazing process is not performed under vacuum, a flux layer should be provided on the tube surface to prevent the formation of an oxide layer. Brazing alloys  
30 comprising aluminium also must be coated with flux.

[0006] The corrosion resistance can be further improved by using a sacrificial layer. In the case of an aluminium zinc alloy, this particular layer being more prone to corrosion than the aluminium alloy forming the tube. Such a sacrificial layer can be provided over the aluminium alloy of the tube either outside, inside or on both sides of it, depending on how corrosive the fluids flowing inside and outside are. Since this sacrificial layer corrodes more quickly than the aluminium alloy of the tube, corrosion occurs only at the surface and the formation of holes in the tube is thereby avoided. In the case that the sacrificial layer is applied to the outside surface of the tube, the brazing alloy is applied to the sacrificial layer. The amount of zinc in the sacrificial layer varies between 5 and 15% by weight. Tests have shown that providing 40 g/m<sup>2</sup> of an aluminium zinc alloy having 10% by weight of zinc gives optimum results.

**Claim:**

Aluminium tube for a heat exchanger made of an aluminium alloy containing manganese.

**International Application published under the Patent Cooperation Treaty**

	(21) International application number:	<b>PCT/ES 2008/00100</b>
	(10) Publication number:	<b>WO 2008/004308 A2</b>
5	(22) Date of filing:	<b>03.01.2008</b>
	(43) Date of publication:	<b>10.07.2008</b>
	(51) Int. Cl.:	<b>F28D1/04</b>
	(71) Applicant:	<b>Sancho Panza S.A.</b>
	(72) Inventor:	<b>Don Quijote</b>
10	(30) Priority data:	<b>200700011 05.01.2007 ES</b>

(81) **Designated States** (unless otherwise indicated for every kind of national protection available): AE, AG, AL, AM, AO, AT, AU, AZ, BA, BB, BG, BH, BR, BW, BY, BZ, CA, CH, CN, CO, CR, CU, CZ, DE, DK, DM, DO, DZ, EC, EE, EG, ES, FI, GB, GD, GE, GH, GM, GT, HN, HR, HU, ID, IL, IN, IS, JP, KE, KG, KM, KN, KP, KR, KZ, LA, LC, LK, LR, LS, LT, LU, LY, MA, MD, ME, MG, MK, MN, MW, MX, MY, MZ, NA, NG, NI, NO, NZ, OM, PG, PH, PL, PT, RO, RS, RU, SC, SD, SE, SG, SK, SL, SM, SV, SY, TJ, TM, TN, TR, TT, TZ, UA, UG, US, UZ, VC, VN, ZA, ZM, ZW.

(84) **Designated States** (unless otherwise indicated for every kind of regional protection available): ARIPO (BW, GH, GM, KE, LS, MW, MZ, NA, SD, SL, SZ, TZ, UG, ZM, ZW), Eurasian (AM, AZ, BY, KG, KZ, MD, RU, TJ, TM), European (AT, BE, BG, CH, CY, CZ, DE, DK, EE, ES, FI, FR, GB, GR, HR, HU, IE, IS, IT, LT, LU, LV, MC, MT, NL, NO, PL, PT, RO, SE, SI, SK, TR), OAPI (BF, BJ, CF, CG, CI, CM, GA, GN, GQ, GW, ML, MR, NE, SN, TD, TG).

15 **Heat exchanger assembly**

## Abstract

20 The heat exchanger assembly comprises at least two heat exchangers. Each heat exchanger comprises headers, tubes and a set of fins extending between the tubes of the first heat exchanger and the tubes of the second heat exchanger. The tubes may be coated externally with an aluminium zinc alloy in order to protect them against corrosion. Using an aluminium zinc alloy providing from 1 g/m<sup>2</sup> to 4 g/m<sup>2</sup>, preferably 2 g/m<sup>2</sup>, of zinc has given the best results.

## Heat exchanger assembly

**[0001]** The present invention relates to a heat exchanger assembly. In particular, it relates to a heat exchanger assembly for a vehicle comprising two heat exchangers, e.g. a radiator and a condenser.

**[0002]** Nowadays vehicles are provided with a condenser for cooling the refrigerant of the air conditioner cycle and a radiator for cooling the water used as engine coolant. The condenser and the radiator both use external air to cool the refrigerant and the water, respectively. Both heat exchangers are provided with headers or tanks, tubes and fins between the tubes, and are arranged in series with respect to the direction of the air flow at the front part of the vehicle. Due to the fact that space in the front part of the vehicle is restricted, there is a need to improve the relative arrangement of the radiator and the condenser.

**[0003]** The aim of the present invention is therefore to optimize the arrangement of the heat exchanger assembly.

**[0004]** This is achieved by the heat exchanger assembly defined in the claim.

**[0005]** An example of the invention is described with reference to the accompanying figures.

**[0006]** Figure 1 discloses a condenser 10 and a radiator 20. The condenser 10 has inlet and outlet headers 11, 12 and tubes 13 disposed between the headers. Refrigerant entering through the inlet header exchanges heat with air flowing between the tubes. In this way the refrigerant is cooled and condensed, leaving the condenser through the outlet header 12. Parallel to the condenser 10, the radiator 20 is placed having inlet and outlet headers 21, 22 and parallel tubes 23 in between. In the radiator, water flowing through the tubes exchanges heat with the air passing between the tubes via fins 30, and is therefore cooled.

[0007] To optimize the relative arrangement of the condenser and the radiator, a fin 30 is common to the condenser and the radiator. As seen in figure 2, which is a cross-sectional view of figure 1, the set of sinusoidal fins 30 extends between the condenser tubes 13 and between the radiator tubes 23.

5

[0008] The fins are usually made of aluminium or an aluminium alloy, as are the other components of the heat exchanger assembly. The fins are fixed to the tubes by brazing. The brazing alloy is applied to the tubes and headers before mounting the heat exchanger assembly. Flux is then applied electrostatically as a dry powder on the mounted heat exchanger assembly, which is then introduced into a furnace for brazing under a controlled atmosphere. The flux layer prevents the formation of an oxide layer on the heat exchanger assembly.

10

[0009] In a preferred embodiment the tubes may be coated externally with an aluminium zinc alloy in order to protect them against corrosion. This is particularly useful in a radiator and a condenser of a vehicle, since external air can include very corrosive substances. Using an aluminium zinc alloy providing from  $1 \text{ g/m}^2$  to  $4 \text{ g/m}^2$ , preferably  $2 \text{ g/m}^2$ , of zinc has given the best results. In order to braze the heat exchanger assembly, the aluminium zinc alloy layer is applied to the external wall of the tube before the brazing alloy.

15

20

**Claim:**

Heat exchanger assembly comprising at least two heat exchangers, each heat exchanger comprising headers and tubes, characterized by having a set of fins extending between the tubes of the first heat exchanger and the tubes of the second heat exchanger.

25

Fig. 1

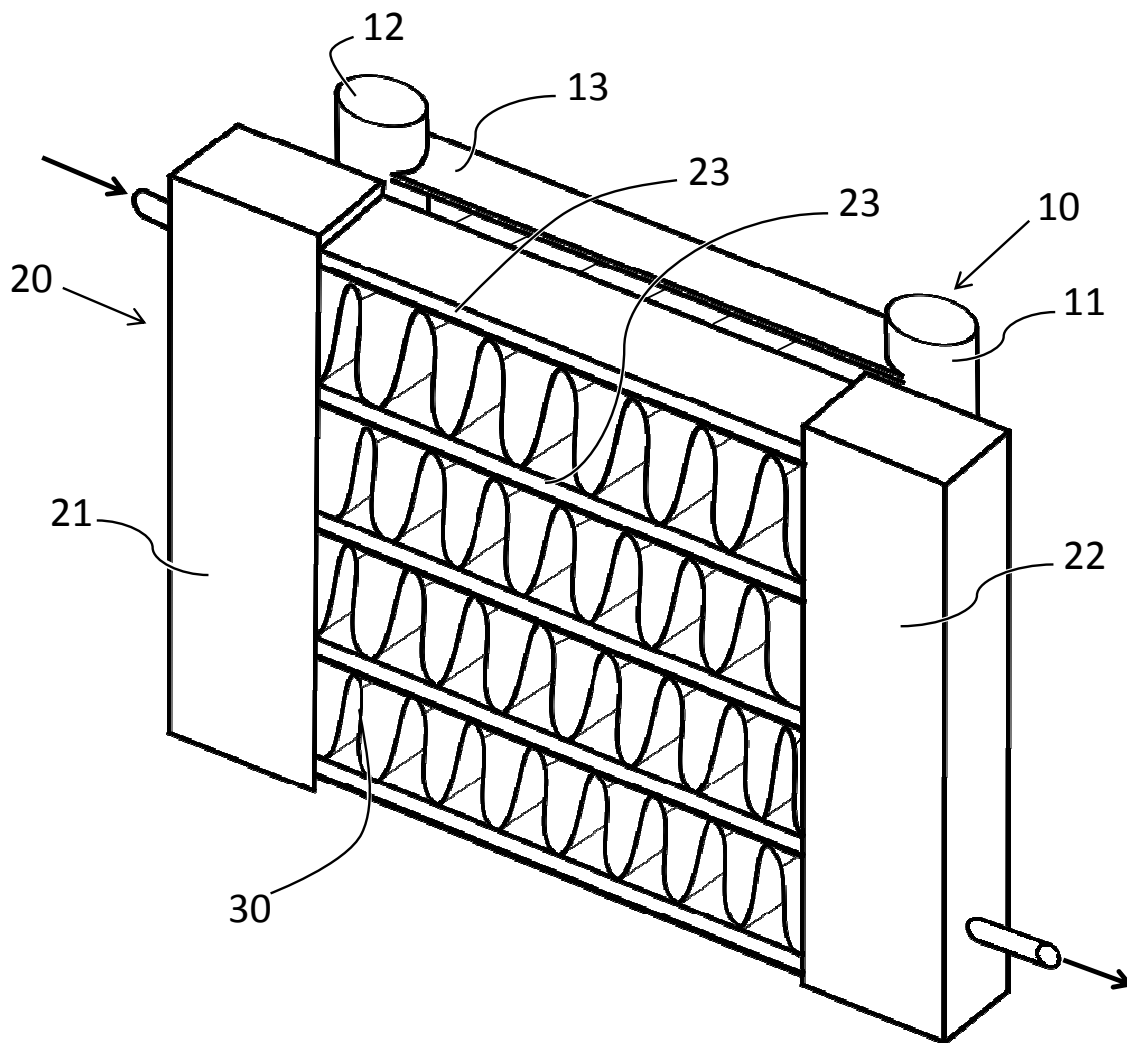
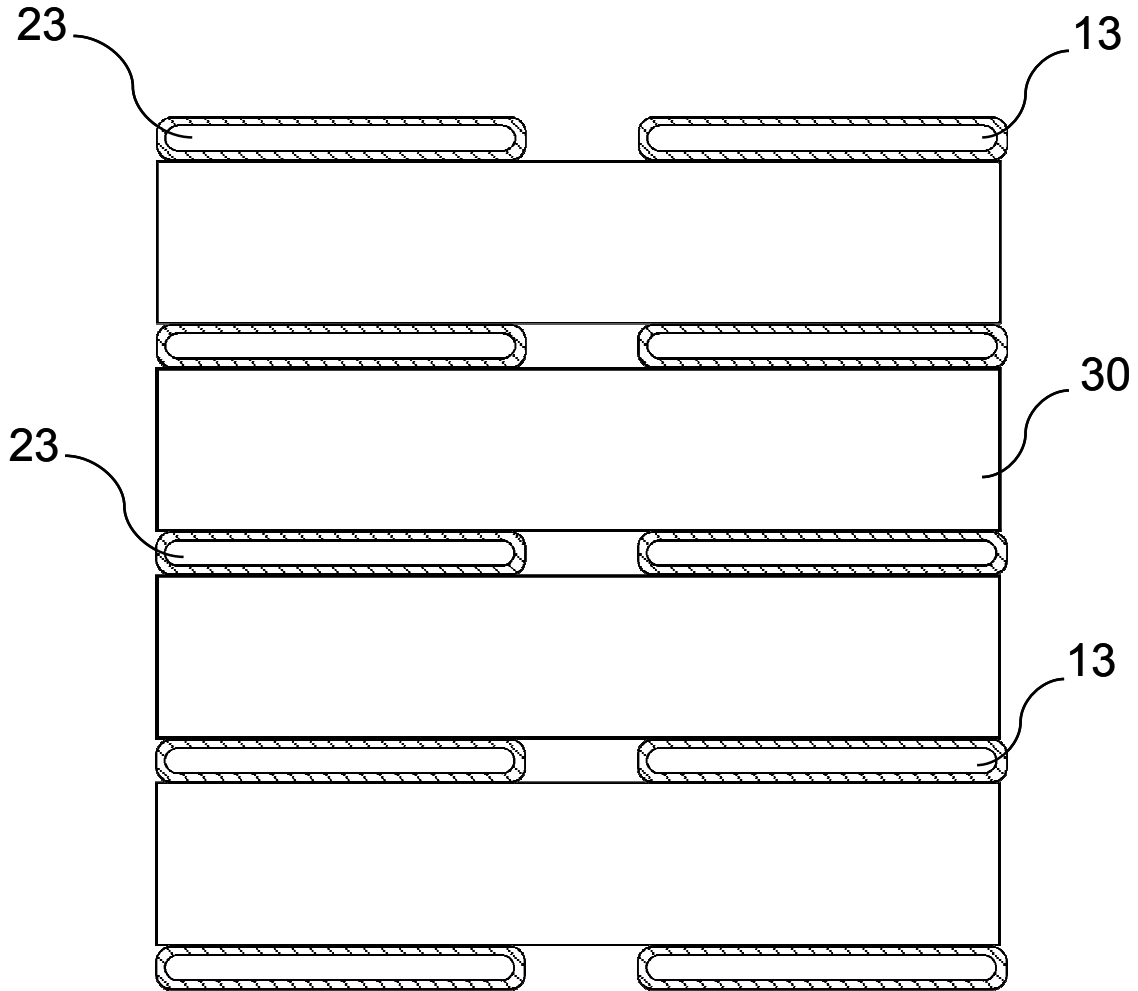



Fig. 2



**Automobile Technology Today, 39 (1970), May, No. 1, page 4**

**Developments in heat exchangers having a tube/fin design**

5 Heat exchangers of a tube/fin design consist of two headers, parallel tubes connecting the headers and sinusoidal fins between the tubes. The heat exchange efficiency is optimized by choosing a particular periodicity of the sinusoidal fin.

10 Recent developments allow brazing the metal components of a heat exchanger in an atmosphere containing traces of air or oxygen. This is possible by the application of a flux layer to the components of the heat exchanger or to the brazing alloy coating them. The flux prevents the formation of an oxide film on the surface of the metal components.

15 Such a heat exchanger may be manufactured in the following way. The headers and the tubes are coated with a brazing alloy. A plate-shaped material is fed to a pair of rotating rollers provided with teeth, thereby obtaining a sinusoidal plate. The sinusoidal plate and the coated tubes and headers are sprayed with a mixture of water and flux, and dried using e.g. infrared lamps. After cutting the dried sinusoidal plate into fins, the dried components are assembled and introduced into an oven for brazing.

20 These developments are particularly important for brazing aluminium heat exchangers, since aluminium is particularly susceptible to oxidation.

## Notes to the notice of opposition (EPO Form 2300)

Although the opposition form is not mandatory for the purpose of filing a notice of opposition, it specifies all the information required for such a notice to be admissible and hence facilitates the formulation and processing of the opposition. In stating and explaining the grounds for opposition, the opponent is free to comment as he wishes.

Explanatory notes to the various sections:

### I. Patent opposed

Under **Patent No.** the number of the European patent against which opposition is filed (Rule 76(2)(b) EPC) must be given.

If known, the **application number and the date on which the Patent Bulletin mentions the grant** (Art. 97(3) EPC) should also be given. The latter makes it easier to monitor compliance with the opposition period.

The **title of the invention** must be given (Rule 76(2)(b) EPC); it should be indicated **as shown on the cover page of the printed patent specification** under item 54.

### II. Proprietor of the patent

Where there are **several** patent proprietors, it is sufficient for the proprietor first named in the patent specification (under item 74) to be given.

### III. Opponent

The **name, address and nationality** of the opponent and the **state** in which his residence or principal place of business is located must be given, in accordance with Rule 41(2)(c) EPC (Rule 76(2)(a) EPC). If the identity of the opponent has not been established by expiry of the opposition period, such deficiency can no longer be remedied (decision of the Technical Board of Appeal T 25/85, OJ EPO 1986, 81).

### IV. Authorisation

If the opponent has appointed a **representative**, his name and the address of his place of business must be given, in accordance with Rule 41(2)(c) EPC (Rule 76(2)(d) EPC). If **several** professional representatives are appointed, only one representative to whom notification is to be made should be named. Any further representatives must be named in an annex (please put a cross in the appropriate box). In the case of an association of representatives, only the name and address of the association must be entered (see Rule 143(1)(h)).

of the EPC contracting states must be represented and act through his representative (Art. 133(2) EPC). Professional representation before the EPO may only be undertaken by professional representatives (Art. 134(1) EPC) or legal practitioners entitled to act as professional representatives (Art. 134(8) EPC).

Natural or legal persons having their residence or principal place of business within the territory of one of the EPC Contracting States may also be represented in opposition proceedings by an **employee**, who must, however, be authorised (Art. 133(3), first sentence, EPC). In this case notification will be made to the opponent (not the employee) unless a professional representative has also been authorised.

To avoid delaying the proceedings, any authorisation which has to be filed should if possible be enclosed with the opposition. Under Rule 152(1) EPC in conjunction with the decision of the President of the EPO dated 12 July 2007, listed professional representatives identifying themselves as such normally no longer need to file signed authorisations (cf. Special edition No. 3, OJ EPO 2007, L.1.). These are, however, required from legal practitioners and employees who are not professional representatives and are acting for the opponent under Articles 134(8) and 133(3), first sentence, EPC respectively. If they do not file an authorisation, the EPO will ask them to do so within a specified period. Failure to comply will result in any procedural steps performed by the practitioner or employee being deemed not to have been taken (Rule 152(6) EPC) – which means that the notice of opposition will be considered not to have been filed.

### V. Statement of the extent to which the patent is opposed

The notice of opposition must contain a statement of the extent to which the European patent is opposed (Rule 76(2)(c) EPC). If the opposition is not filed against the patent as a whole (place a cross in the appropriate box), the number(s) of the claims (as in the patent specification) which the opponent considers to be affected by one or more of the grounds for opposition must be given.

### VI. Grounds for opposition

The alleged grounds for opposition (Art. 100 EPC) must be indicated by a cross in the appropriate box(es).

Under the heading of non-patentability (Art. 100(a) EPC) the most frequently cited grounds for opposition are lack of novelty and lack of inventive step, for

otherwise gives the opponent ample scope for indicating other possible grounds for opposition. Under the heading “other grounds” the following Articles may be cited in the box provided: 52(1) and 57; 52(2); 53(a); 53(b); 53(c) EPC.

A full list of grounds for opposition is given in Article 100 EPC. The following in particular are not admissible grounds: lack of unity of invention (Art. 82 EPC), lack of clarity in the claims (Art. 84 EPC) and prior national rights (Art. 139(2) EPC).

For general information on grounds for opposition see Guidelines for Examination in the EPO, D-III, 5.

## VII. Facts and arguments presented in support of the opposition

The notice of opposition must contain an indication of the facts and evidence presented in support of the opposition (Rule 76(2)(c) EPC) and, where documents are cited, an indication of the relevant part(s) (Guidelines D-IV, 1.2.2.1).

The facts, with the relevant arguments and evidence, in support of the opposition must be presented on a separate sheet enclosed as an annex to the Form (indicated by a pre-printed cross in the box).

The fact that the evidence is listed separately in Section IX does not anticipate the presentation of facts, evidence and arguments but merely makes for greater clarity and simplifies processing of the dossier. Section IX of the Form (Evidence presented) may of course always be referred to in this presentation.

Where documents are cited in shortened form, the rules set out in the Guidelines B-X, 9.1 should be followed.

## VIII. Other requests

This section may be used for example to request oral proceedings or a file inspection.

## IX. Evidence

Published documents cited as evidence (e.g. patent specifications) must be entered under “Publications” in the spaces provided – preferably in order of importance. They should be cited in the manner described in Guidelines B-X, 9.1.

Opponents should also indicate the parts of the document on which the opposition is based (this information has to be given anyway in the statement of facts and arguments – see notes to Section VII above).

Other evidence (e.g. witnesses, affidavits, company brochures, test or expert reports) must be cited under “Other evidence” (for public prior use: place, time, nature – see Guidelines D-V, 3.1.2; D-IV, 1.2.2.1(v):

room, the evidence can simply be listed, with an indication of where in the statement of grounds the relevant particulars appear (e.g. “Witness ..., page 5”).

Documents cited by a party to opposition proceedings must be filed (including publications already cited in the European patent specification) with the notice of opposition or other written submission. This will avoid an invitation from the EPO for subsequent filing thereof. If they are neither enclosed nor filed in due time on invitation, the EPO may ignore any arguments based on them (Rule 83 EPC).

## X. Payment of opposition fee

The opposition fee must be paid within the opposition period. Notice of opposition is not deemed to have been filed until the opposition fee has been paid (Art. 99(1) EPC). With regard to what constitutes the date to be considered as the date on which payment is made, see Article 7 of the Rules relating to Fees and the guidance on payment methods in the Official Journal.

## XI. List of documents enclosed

Please indicate which documents are enclosed by crossing the relevant box.

## XII. Signature

If the opponent is a legal person and the notice of opposition is not signed by the representative, it must be signed:

- (a) either by a person entitled to sign under the law or the opponent’s statute, articles of association or the like, with an **indication of the capacity of the person doing so**, e.g. Geschäftsführer, Prokurist, Handlungsbevollmächtigter; chairman, director, company secretary; directeur, fondé de pouvoir (Art. 133(1) EPC), in which case no authorisation need be filed;
- (b) or by another employee of the opponent, provided the latter’s principal place of business is in a contracting state (Art. 133(3), first sentence; Rule 152(1) EPC), in which case an authorisation must be filed.

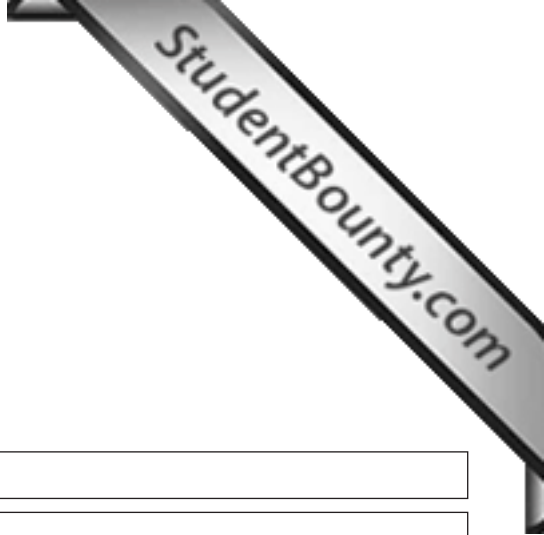

# Notice of opposition to a European patent

## I. Patent opposed

Patent No.

Application No.

Date of mention of the grant in the European Patent Bulletin (Art. 97(3), Art. 99(1) EPC)

Title of the invention

## II. Proprietor of the patent

first named in the patent specification

Opponent's or representative's reference (max. 15 keystrokes)

## III. Opponent

Name

Address

State of residence or of principal place of business

Nationality

Telephone/Fax

Multiple opponents (see additional sheet)

## IV. Authorisation

1. Representative (name only one representative or name of association of representatives to whom notification is to be made)

Address of place of business

Telephone/Fax

Additional representative(s) on additional sheet/see authorisation



2. Name(s) of employee(s) of the opponent authorised to act in these opposition proceedings under Art. 133(3) EPC

Authorisation(s) to 1./2.  not considered necessary

has/have been registered under No.

is/are enclosed

**V. Opposition is filed against**

• the patent as a whole

• claim(s) No(s).

**VI. Grounds for opposition:**

Opposition is based on the following grounds:

(a) the subject-matter of the European patent opposed is not patentable (Art. 100(a) EPC) because:

• it is not new (Art. 52(1); Art. 54 EPC)

• it does not involve an inventive step (Art. 52(1); Art. 56 EPC)

• patentability is excluded on other grounds, i.e. Article

Art.

(b) the patent opposed does not disclose the invention in a manner sufficiently clear and complete for it to be carried out by a person skilled in the art (Art. 100(b) EPC; see Art. 83 EPC).

(c) the subject-matter of the patent opposed extends beyond the content of the application/of the earlier application as filed (Art. 100(c) EPC, see Art. 123(2) EPC).

**VII. Facts (Rule 76(2)(c) EPC)**

presented in support of the opposition are submitted herewith on a separate sheet (annex 1)

**VIII. Other requests:**

**IX. Evidence presented**

Evidence is enclosed   
will be filed at a later date

**A. Publications:**

1  
Particular relevance (page, column, line, fig.):

2  
Particular relevance (page, column, line, fig.):

3  
Particular relevance (page, column, line, fig.):

4  
Particular relevance (page, column, line, fig.):

5  
Particular relevance (page, column, line, fig.):

6  
Particular relevance (page, column, line, fig.):

Continued on additional sheet

**B. Other evidence**

Continued on additional sheet

**Please do not use**

**X. Payment of the opposition fee is made**

- as indicated in the enclosed voucher for payment of fees and costs (EPO Form 1010)
- via EPO Online Services

**XI. List of documents**

Enclosure No.

- 0 Form for notice of opposition
- 1 Facts (see VII.)
- 2 Copies of documents presented as evidence (see IX.)
  - a Publications
  - b Other documents
- 3 Signed authorisation(s) (see IV.)
- 4 Voucher for payment of fees and costs (see X.)
- 5 Additional sheet(s)
- 6 Other

Number of sheets

*Please specify here:*

**XII. Signature of opponent or representative**

Place

Date

Signature

Name (block capitals)

In case of legal persons, signatory's position within company