

EUROPEAN QUALIFYING EXAMINATION 2010

Paper C

This paper comprises:

- * Letter from opponent to professional representative 2010/C/EN/1-2
- * Annex 1 2010/C/EN/3-10
- * Annex 2 2010/C/EN/11-13
- * Annex 3 2010/C/EN/14-17
- * Annex 4 2010/C/EN/18-20
- * Annex 5 2010/C/EN/21-23
- * Annex 6 2010/C/EN/24-25
- * Notes to the notice of opposition (EPO Form 2300),
Form 2300: Notice of opposition to a European patent

Mr Heinz Sicht
L'Oreosol
4 Rue des Klems
44444 Saint Gapour
France

Mr Izzy Goudinov
European Patent Attorney
Zapfengasse 3
87232 Nujork
Germany

Saint Gapour, 01.03.2010

Dear Mr Goudinov,

we would like you to file an opposition on behalf of L'Oreosol against the European patent EP 2 124 343 B1 (Annex 1). We have found some documents (Annexes 2 to 6) which might be of use to you.

Annex 1 is the granted version of the European application 07123000.4 filed on 14.12.2007 as a divisional of the then pending parent European application 06000123.4, filed on 29.06.2006. The parent application claims two priorities: LU12345 (LU1), filed on 30.06.2005 and LU54321 (LU2), filed on 04.04.2006.

A file inspection revealed the following differences with regard to the applications in the patent family:

i) the two priority documents are identical except that plastics as a gas-permeable porous material is mentioned for the first time in the second priority document LU2.

0000000000

ii) the parent application as filed on 29.06.2006 was identical to LU2 except that introduced for the first time the subject-matter of claim 6 and the last sentence of paragraph [0014] of Annex 1.

Are these observations relevant for our case?

We further discovered that the text of claim 5 on which the decision to grant the patent was based and which was accepted by the applicant reads "1.8 μm " (micrometres) and not "1.8 mm" (millimetres) as is now the case in the patent specification. Does this affect our opposition?

We learned that the proprietor validly filed last week a request for limitation of Annex 1. How does this affect us, and is it advisable to wait for the outcome of the limitation procedure before filing an opposition?

With our best regards,

Heinz Sicht

Enclosures:

Annex 1: EP 2 124 343 B1

Annex 2 : EP 0 535 091 A1

Annex 3: US 2005/0005100 A1

Annex 4: EP 1 747 913 A1

Annex 5: WO 96/00379 A1

Annex 6: EP 1 798 231 A1

(19)  **Europäisches Patentamt**
European Patent Office
Office européen des brevets

(11) **EP 2 12**

(12) **EUROPEAN PATENT SPECIFICATION**

(45) Date of publication and mention
of the grant of the patent:

(51) Int. Cl.⁷: **B65D83/00**

10.06.2009 Bulletin 2009/25

(21) Application number: **07123000.4**

(22) Date of filing: **29.06.2006**

(54) **Improvements relating to pressurized containers**

Verbesserungen bei unter Druck stehenden Behältern

Améliorations relatives à des récipients pressurisés

(84) Designated Contracting States:

DE DK ES FR GB

(73) Proprietor:

Clearspray
44 rue Toc
8303 Champs-Gailles (LU)

(30) Priority:

30.06.2005 LU12345
04.04.2006 LU54321

(72) Inventor:

Toulouse, Björn
2 rue Tabaga
28302 Bouey-Nozères (FR)

(43) Date of publication of application:

07.01.2009 Bulletin 2009/01

(74) Representative:

Sari, Yule B.
Dewey, Cheetham & Howe
23 Escape Rd
B15 2TT Birmingham (GB)

(62) Document number of the earlier
application in accordance
with Art. 76 EPC:

06000123.4 / 0 843 763

Note: Within nine months from the publication of the mention of the grant of the European patent, any person may give notice to the European Patent Office of opposition to the European patent granted. Notice of opposition shall be filed in a written reasoned statement. It shall not be deemed to have been filed until the opposition fee has been paid (Art. 99(1) European Patent Convention).

[0001] The present invention relates to a device for reliably dispensing a predetermined dose of a pressurized liquid product, which is preferably a pharmaceutical product.

5 **[0002]** Dispensers of the aerosol type which include a container comprising a pressurized propellant used to expel a liquid product are known. In most of these dispensers, the propellant employed is a gas which readily forms a liquid phase when it is pressurized in the container and is then called a liquefied gas or liquefied propellant. As the propellant is kept under pressure in the container, typically at 400 to 500 kPa, it stays in its liquid form as long as the pressure is maintained.

10

[0003] In these dispensers, the container is equipped with a valve which carries an operating member that can be actuated to trigger the release of the liquid product from the valve and a dip tube to convey the liquid product into the valve through a valve inlet. When the operating member is actuated, for example by being depressed, the valve
15 opens, which causes the pressure in the dispenser to be reduced. As a result, liquefied propellant starts to vaporize, forming an expanding gas in the container, which then drives the liquid product up the dip tube into the valve before it is propelled as an aerosol out of the dispenser.

20 **[0004]** In most dispensers, the liquefied propellant kept in the container is either simply mixed with the liquid product to be expelled, or it can be enclosed in a trapping material in the form of one or more porous bodies freely floating inside the container. The material from which the porous bodies are made is chosen so that the porous bodies can trap the liquid phase of the propellant and are also permeable to gases to release
25 the propellant in the gaseous phase when the valve is open. It is known in the art that the use of a trapping material to enclose the liquefied propellant prevents accidental waste of liquefied propellant.

[0005] However, the presence of free bodies of trapping material in the container frequently leads to a malfunction of the dispenser by clogging the openings of the valve such as the dip tube or any additional inlet. The present invention aims at preventing losses of liquefied propellant while avoiding the obstruction of the dip tube or any additional inlet.

[0006] Figure 1 shows a dispenser according to the invention. Figure 2 shows a valve according to the invention in its open position, i.e. open to the outside atmosphere. Figure 3 shows the same valve in its closed position, i.e. closed to the outside atmosphere.

[0007] The dispenser comprises a container 10 made of plastics, a liquid product 11 to be dispensed, which can be a pharmaceutical product, and a liquefied propellant 12 stored in a trapping material 13, coated on the inner surface 10a of the container wall. Although the majority of the propellant is in a liquid state in the trapping material, some propellant in the gas phase is also present in the container. Additionally, a dip tube 14 runs from near the bottom of the container up to a valve 15 at the top of the container.

[0008] The trapping material is able to absorb and store the pressurized liquefied propellant. It should further adhere to the inside surface of the container wall made of plastics so that clogging of the dip tube or of the valve is reduced as compared to systems where the trapping material is floating inside the container. The trapping material is preferably made of nylon, PVC or latex.

[0009] In order to dispense a predetermined dose of pharmaceutical product, the dispenser is preferably mounted with a metering valve comprising a valve housing 110 defining a valve chamber 111 of predetermined volume, with a lower opening (valve inlet 112) through which the liquid pharmaceutical product under pressure can enter the valve chamber. Furthermore, an operating member 113 provides an ejection passage (valve outlet 114) for the aerosol and engages the valve inlet 112 when the operating member is actuated (valve open to the outside atmosphere, Fig. 2).

5 [0010] During actuation of the operating member by downward pressure, the flow of liquid pharmaceutical product from the dip tube to the interior of the housing is interrupted. Thus, the discharge of liquid pharmaceutical product through the outlet 114 is limited to the amount of liquid product which was present in the valve chamber before actuation. When the operating member is released (valve closed to the outside atmosphere, Fig. 3), the liquid pharmaceutical product under pressure is conveyed from the dip tube through the inlet 112 into the interior of the valve chamber where it is confined.

10 [0011] The valve housing 110 comprises a material which is permeable to gases through the presence of pores within the material. Upon actuation of the valve, the pressurized propellant gas diffuses through the wall of the valve housing into the valve chamber. Ceramic or plastics can be used for the porous valve material as they can be made gas-permeable using methods known in the art.

15 [0012] Under a propellant pressure of 400 to 500 kPa, the use of a valve housing made of a gas-permeable porous material with a pore size selected in the narrow range of 1 μm to 3 μm produces an aerosol that can be expelled from the dispenser over a greater distance than when the pore size of the gas-permeable porous material is chosen outside this range.

20 [0013] When the pore size of the valve housing material is less than 1.8 μm , the pores of the material are so small that a liquid cannot percolate through the housing. Therefore, any accidental release of liquid through the pores of the valve housing, for instance when the dispenser is tilted upon use, is prevented.

[0014] Preferably, the dip tube 14 is made of a flexible material so that the tube easily move as the container is tipped, maintaining the free end of the tube immersed even when little liquid product remains in the container. Tubes made of silicone are used as they are more flexible than tubes made of polyethylene such as high density polyethylene (HDPE), and can therefore bend more easily upon tilting of the container.

[0015] The service life of the dispenser can be prolonged in two ways. First, a trapping material comprising latex may be used as it can releasably trap higher quantities of liquefied propellant as compared to other suitable materials. Alternatively, additives may be included in the propellant or absorbed within the trapping material enclosing the propellant. When the additives present in the dispenser are not compatible with pharmaceutical regulations, they contaminate the liquid pharmaceutical product. The pharmaceutical product then needs to be isolated from the additive by packaging it in a separate plastics pocket in the container. The opening of the pocket is hermetically attached around the valve with the dip tube plunging into the pocket.

Claims

1. A dispenser comprising a pressurized container (10) made of plastics, a liquid product (11) to be dispensed, a liquefied gas as a propellant (12), a valve (15) coupled with the container (10) and a dip tube (14) extending into the liquid product (11), and wherein the container wall is coated on its inner surface (10a) with a trapping material (13) in which propellant (12) is releasably trapped.
5
2. The dispenser of claim 1 wherein the trapping material (13) comprises latex.
10
3. The dispenser of claim 1 comprising within it a supple plastics pocket communicating with the valve (15), wherein the pocket contains the liquid product (11) and isolates it from the propellant (12).
4. A valve comprising a valve housing (110) provided with an inlet (112) and an operating member (113) having an outlet (114), said operating member being movable between a closed position and an open position and wherein the operating member is such that, by actuation thereof, the inlet (112) is closed before the outlet (114) is opened and wherein the valve housing comprises a gas-permeable porous material, the pores of which are between 1 μm and 3 μm in size and said material being ceramic or plastics.
15
20
5. The valve of claim 4 wherein the pore size is less than 1.8 mm.
6. The valve of claim 4 further comprising a silicone dip tube connected to the valve housing (110) and wherein the gas-permeable porous material is ceramic.
25

Fig. 1

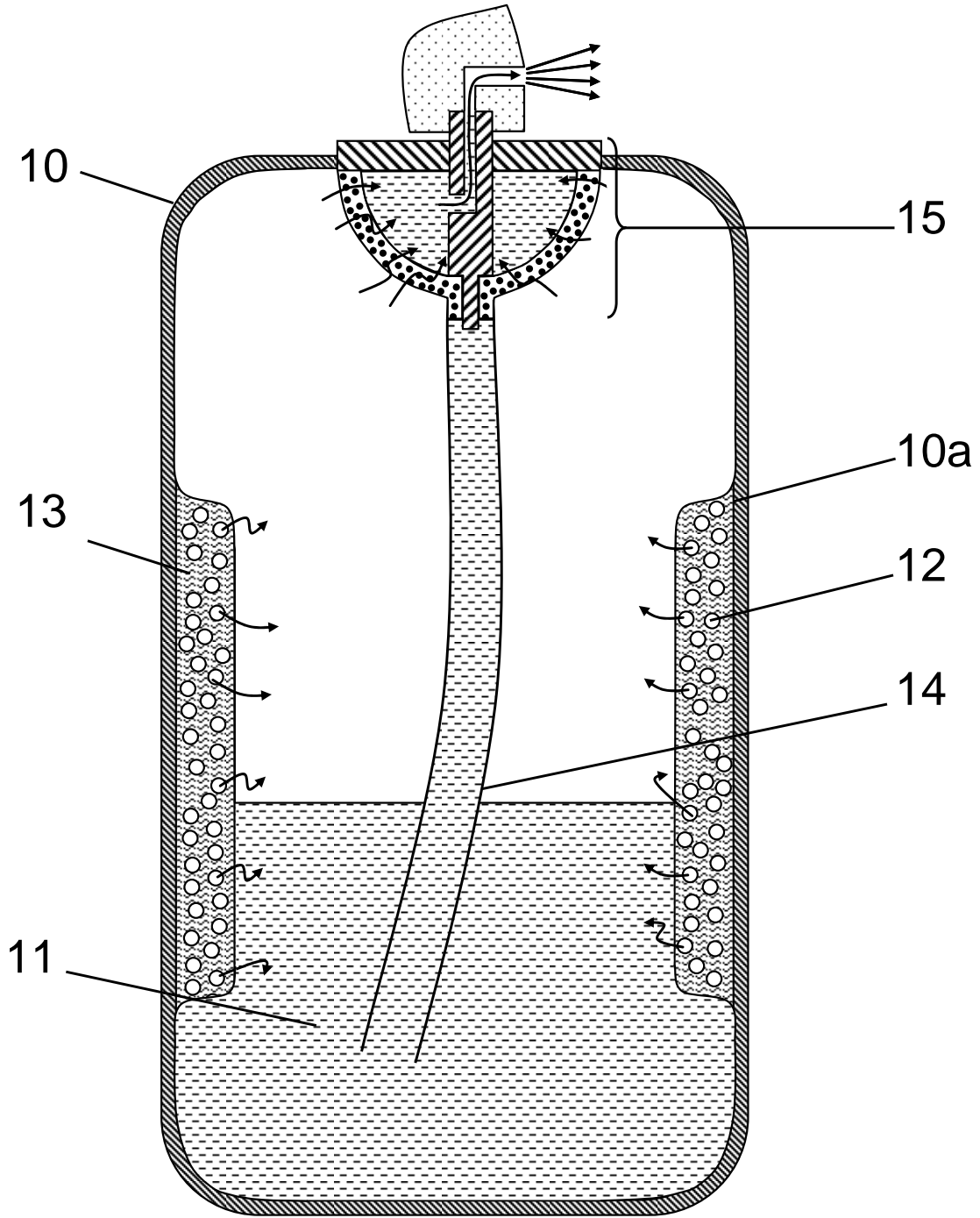

Fig. 2

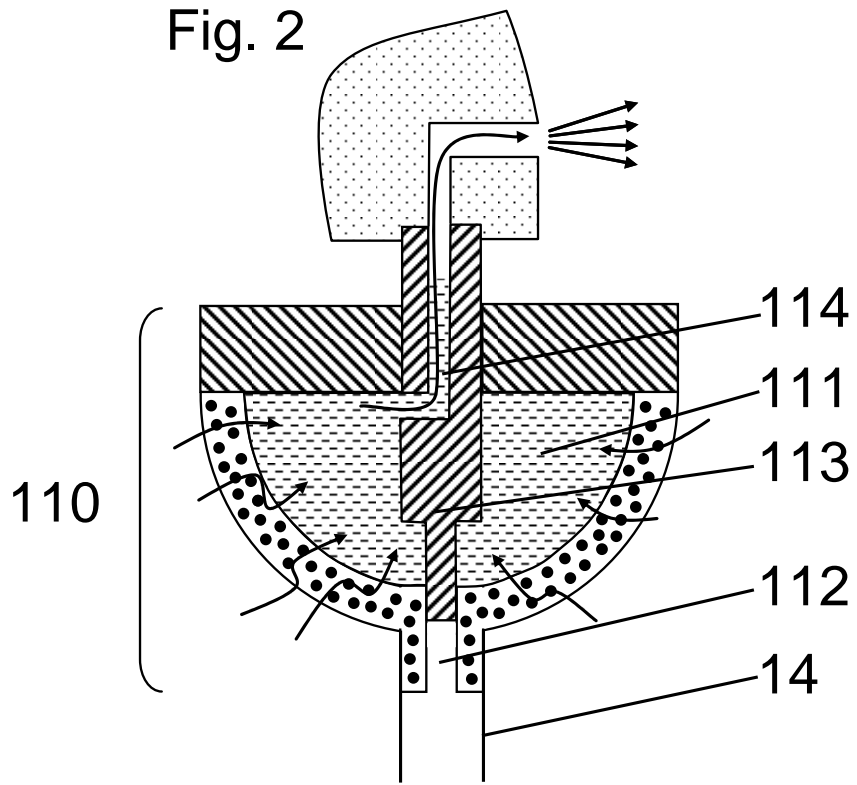
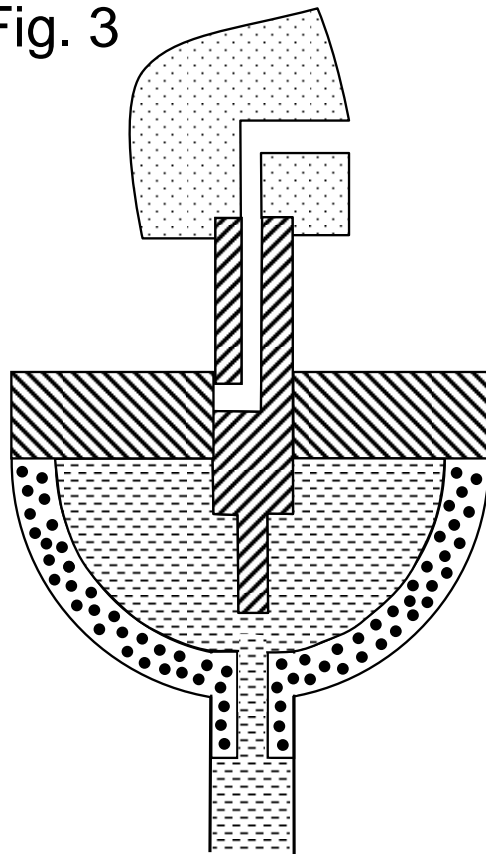

Fig. 3



- (19) **European Patent Office**
- (12) **European Patent Application**
- (21) Application number: **86915133.8**
- (11) Publication number: **EP 0 535 091 A1**
- 5 (22) Date of filing: **26.05.1986**
- (43) Date of publication: **16.11.1987**
- (51) Int. Cl.: **B65D83/16**
- (71) Applicant: **AERO**
- (72) Inventor: **Colbier, Anita; Opener, Ken**
- 10 (84) Designated Contracting states: **AT BE CH DE ES FR IT LI LU NL
SE GB**

Pressurized gas apparatus

15 **[0001]** The present invention relates to an apparatus for dispensing a pressurized gas. The gas used in the invention can be any gas that can be converted to its liquid state under a pressure of 400 to 500 kPa. The liquefied gas is then stored within a gas-permeable porous material adhering to the inside wall of a can and vaporizes in the can before being expelled. Thus, accidental release of liquefied gas through the open valve
20 when the apparatus is tilted during use is prevented.

[0002] The apparatus comprises a can 20 and a gas-permeable porous material 25 adhering to the inside wall of the can and enclosing the liquid phase of a gas 26 under pressure. Furthermore, the can is equipped with a valve assembly comprising a
25 spherical member 21 with an inlet 22 through which the gas is discharged. A lever member 23 is attached to the spherical member 21 to actuate the valve by applying force to said lever member against the action of a spring 24. As the spring 24 is compressed, the spherical member with inlet 22 rotates such that the pressurized gas within the container is discharged.

5 [0003] The gas-permeable porous material 25 suitable herein is permeable to gas in order to allow the liquefied gas to rapidly vaporize and diffuse in the can upon actuation of the valve. Thus, irrespective of the tilt angle of the apparatus, only gas is expelled from the can. Furthermore, said material 25 must adhere to the inside wall of the can in order to avoid clogging of the inlet 22 by loose parts of it, when the can is tilted, hindering the proper operation of the gas dispenser. Suitable materials may be PVC, nylon or latex which can all be made porous using known processes. A latex-comprising material is preferred as it is able to contain higher quantities of liquefied gas.

10 [0004] The can 20 is made of a material that must be able to withstand a pressure of 500 kPa and must offer good adhesion to the gas-permeable porous material 25. Only plastics were found to satisfy these requirements and were therefore used for the apparatus disclosed herein. Although metals would provide higher can strengths, they do not afford a satisfactory adhesion to any of the known gas-permeable porous materials.

Claim:

20 Pressurized apparatus for dispensing a pressurized gas containing a liquefied gas stored within a material coated on the inside wall of a plastics can.

Fig.

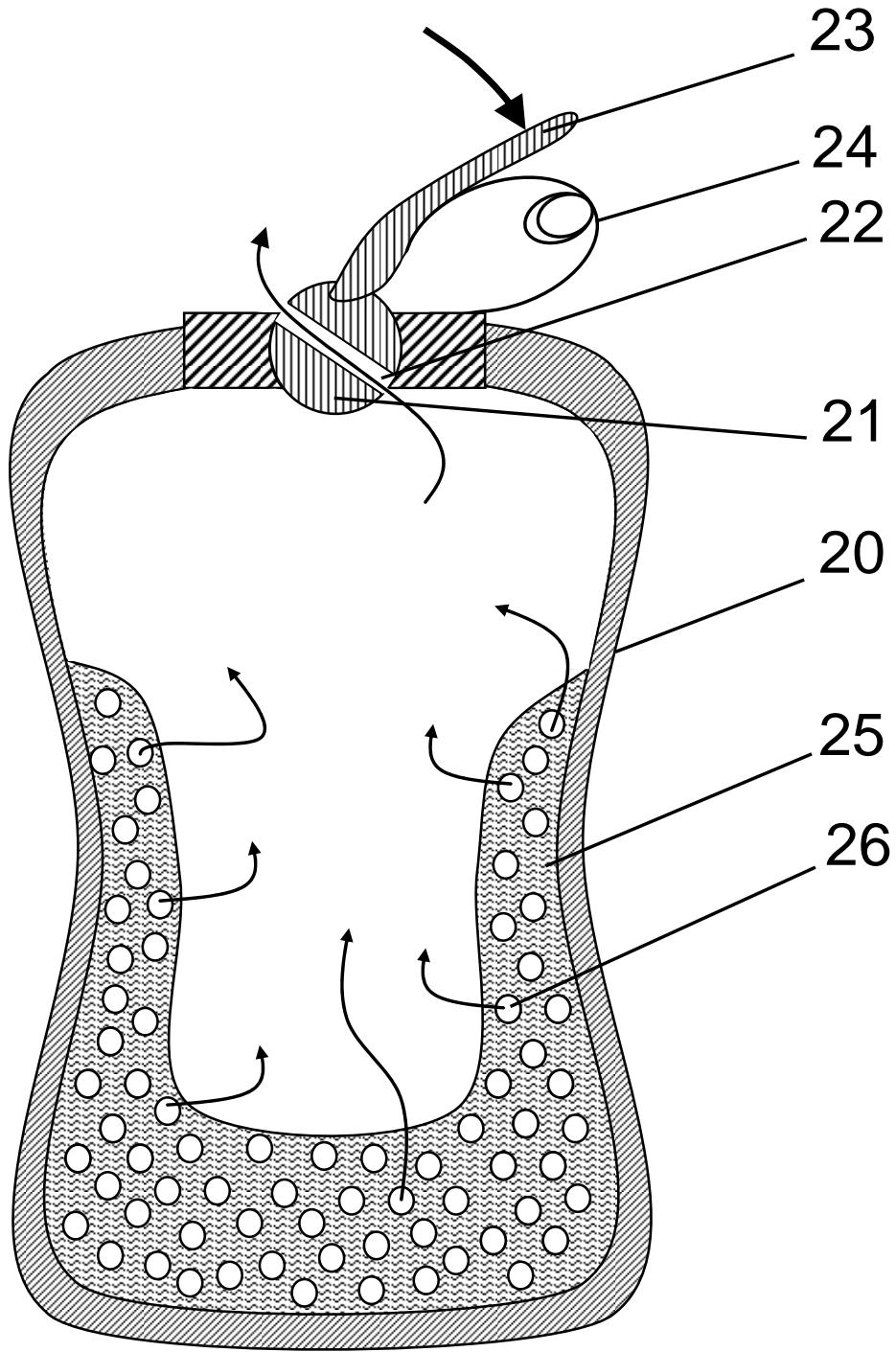

(19) **United States**

(12) **Patent Application Publication**

(21) Appl. No.: **10/174,172**

(10) Pub. No.: **US 2005/0005100 A1**

5 (22) Filed: **2 January 2004**

(43) Pub. Date: **27 June 2005**

(51) Int. Cl.: **B65D83/00**

(73) Assignee: **LIMBO Inc.**

(75) Inventor: **Itmiselph, Aldo**

10 (54) **Liquid spray bottle for medical applications**

[0001] This invention relates to a pressurized aluminium bottle for use in medical environments which can continuously spray a medical solution stored in a collapsible plastics pouch within the bottle.

15

[0002] The spray bottle of the invention comprises an aluminium bottle 30 and a valve 31 including a gas-permeable porous valve housing 34 with a hollow piston 32 able to move in the housing between a valve-closed position and a valve-open position. By downward pressure on the piston, a passage is created between the gas-permeable porous valve housing 34 and the outside of the bottle, allowing a continuous spray of

20 medical product as long as the piston is depressed.

[0003] The pressurized bottle of the invention must be able to withstand an internal pressure of 1000 kPa without permanently distorting in order to meet the safety standards of the US Department of Transport. To comply with these standards, only

25 metals were considered as only they can provide the necessary bottle strength. Aluminium was chosen as it is lightweight and cost effective.

[0004] The spray bottle also comprises a flexible and collapsible plastics pouch 33

30 mounted on the valve 31. The pouch contains the medical solution 35.

[0005] A propellant is used to expel the solution from the bottle. The propellant is a liquefied propellant 36 under a pressure of 400 to 500 kPa and is confined within the bottle in the compartment 37 defined by the inside wall of the bottle and the outside wall of the pouch. As the medical solution is isolated from the liquefied propellant by the pouch, a propellant additive, which would otherwise contaminate the medical solution, may advantageously be added to the compartment 37.

[0006] There is always a gaseous phase of propellant above the liquid phase since part of the propellant confined in the compartment 37 vaporizes. When the valve 31 is in its open position, the solution contained in the pouch enters the valve as the pouch is under pressure generated by the gaseous propellant.

[0007] The pressurized gaseous propellant present in the compartment 37 rapidly passes through the gas-permeable porous valve housing 34 when the valve is actuated and provides the pressure needed to expel the solution from the bottle. The pressure of propellant in the valve is such that the flow of the spray is maintained during spraying even when the medical product is continuously sprayed over long periods of time.

[0008] The gas-permeable porous valve housing 34 is made of a gas-permeable porous plastics material using methods known in the art. Although plastics housings having a wide range of pore sizes ranging from 0.1 μm to 20 μm were considered, the distance reached by the spray was maximized with a pore size greater than about 0.5 μm , but below about 2.5 μm .

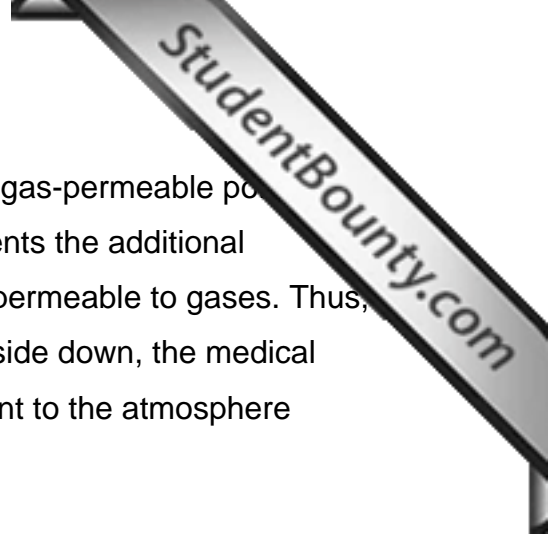

[0009] A gas-permeable porous valve housing 34 made of a gas-permeable porous plastics material having a pore size below about 2.0 μm presents the additional advantage of being simultaneously impervious to liquids and permeable to gases. Thus, when spraying the medical solution with the bottle tilted or upside down, the medical solution can be dispensed without releasing liquefied propellant to the atmosphere through the pores of the valve housing.

Claim:

10 Aluminium spray bottle for continuously spraying a medical solution which is stored in a collapsible plastics pouch, wherein the bottle comprises a gas-permeable porous valve housing made of a gas-permeable porous plastics.

Fig.

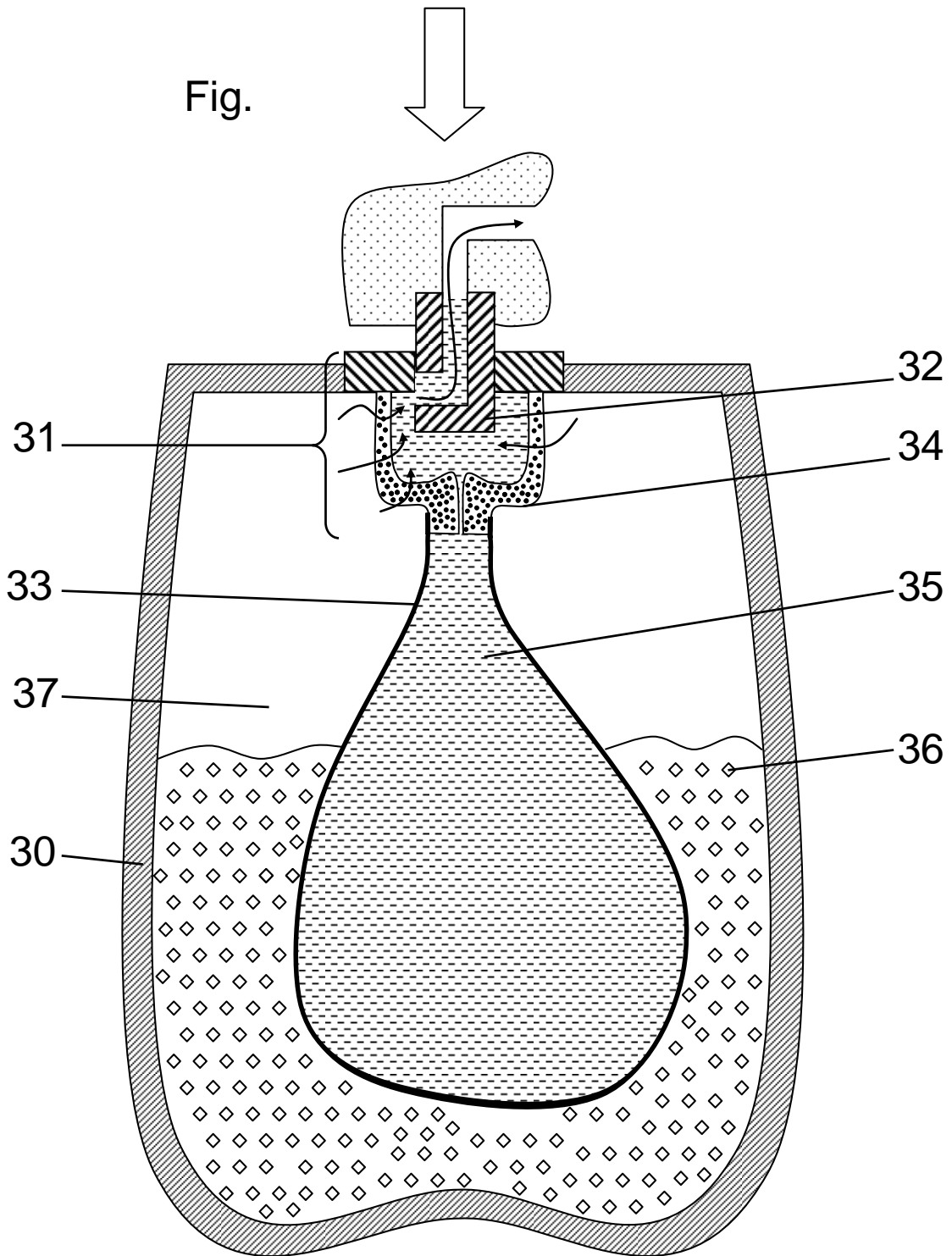

- (19) **European Patent Office**
- (12) **European Patent Application**
- (21) Application number: **04181133.8**
- (11) Publication number: **EP 1 747 913 A1**
- 5 (22) Date of filing: **02.08.2004**
- (43) Date of publication: **02.02.2006**
- (51) Int. Cl.: **B65D83/38**
- (71) Applicant: **Pharmasol**
- (72) Inventor: **Raphone, Mike**
- 10 (84) Designated Contracting states: **DE DK ES FR GB**

Device for a metered delivery of pharmaceutical aerosols

[0001] The present invention relates to a device for dispensing an aerosol of a liquid pharmaceutical product. The device comprises a pressurized receptacle mounted with a metering valve made of a gas-permeable porous plastics material and a liquefied propellant mixed with the product to be dispensed under pressure.

[0002] The device according to the invention comprises a plastics receptacle 40 having a metering valve which comprises a wall 41 made of a gas-permeable porous plastics material. A polyethylene extraction tube 47 extends from the metering valve into a liquid pharmaceutical product 48 mixed with a liquefied propellant 46. A pressure of 400 to 500 kPa in the receptacle ensures that most of the propellant is in the liquid phase, with some propellant in its gaseous phase in the upper part of the receptacle.

25 The receptacle 40 is made of transparent plastics as it allows a continuous monitoring of the level of liquid pharmaceutical product in the device.

[0003] A metering valve is employed to enable the user to dispense a fixed volume of liquid pharmaceutical product upon actuation of the valve. The valve comprises a chamber 42 of fixed volume with an inlet 43a and an outlet 43b controlled by displacement of a valve member 44. Operation of the metering valve requires the chamber to be filled via the valve inlet 43a; the actuation of the valve member 44 closes the inlet 43a and opens the outlet 43b such that the content of the valve chamber is expelled to the atmosphere.

[0004] Additionally, the valve wall 41 is made of a gas-permeable porous plastics material so that the gaseous propellant under pressure diffuses through said wall into the valve chamber where it mixes with the liquid pharmaceutical product before the mixture is expelled from the device as an aerosol. Tests have shown that a device incorporating a valve made of a gas-permeable porous material with a pore size selected between 0.1 μm and 20 μm produces an aerosol that is dispensed over a greater distance as compared to a device with a non-porous valve.

[0005] Particles of stabilizing agents 49, can be mixed with the liquid pharmaceutical product to protect it from light radiation passing through the transparent receptacle. A thick layer of material 45 forms over time within the receptacle when the stabilizing agents are dispersed in the liquid product. This material, which has the appearance of a foam, sticks to the inside wall of the receptacle. Some propellant 46 in its liquid and gaseous phase is temporarily incorporated in this foam-like material.

Claim:

25 Device for dispensing a liquid pharmaceutical product comprising a metering valve having a gas-permeable porous wall.

Fig.

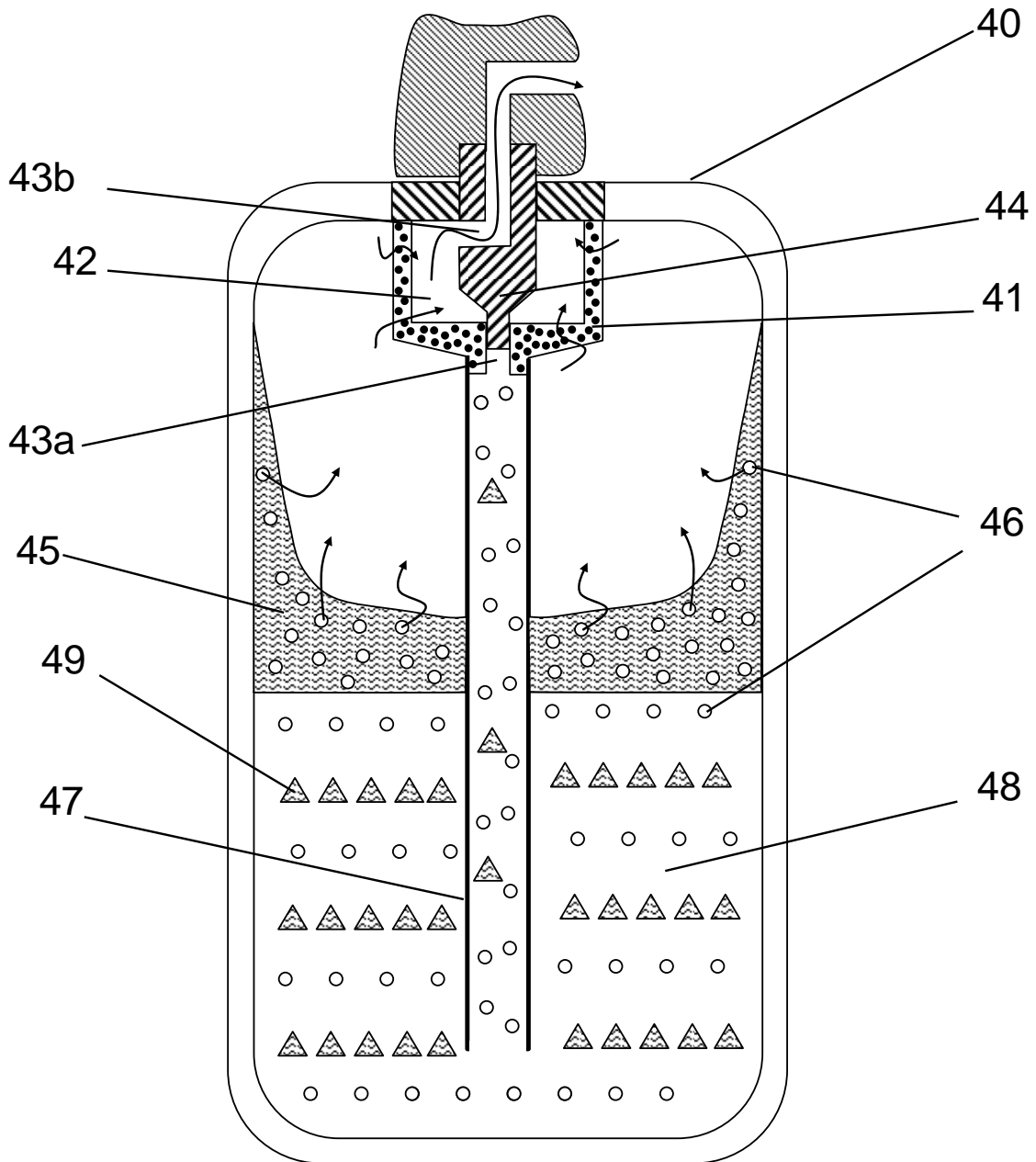

PCT**INTERNATIONAL APPLICATION PUBLISHED UNDER THE PATENT
COOPERATION TREATY (PCT)**

- (21) International Application number: **PCT/US95/05001**
- 5 (11) International Publication number: **WO 96/00379 A1**
- (22) International Filing Date: **09.06.1995**
- (43) Date of publication: **09.12.1996**
- (51) International Patent Classification: **B65D83/34**
- (71) Applicant: **PROPEX**
- 10 (72) Inventor: **Briccant, Lou**
- (81) Designated States: **AU BG BR CA RU UA European
patent (DE DK ES FR GB PT)**
- (54) Title: **Pressurized apparatus for dispensing an aerosol**

15 **[0001]** The present invention relates to a pressurized apparatus for dispensing an aerosol, which comprises a container 51 made of plastics and which contains a mixture of a liquid product 52 and a liquefied propellant 53 under a pressure of 400 to 500 kPa.

20 **[0002]** The container is equipped with a valve 54 allowing a continuous and prolonged expulsion of the liquid product. The valve carries an eduction pipe 55 reaching towards the bottom of the container and causing the liquid product in the container to enter the valve. An orifice 57, formed in the valve 54, allows some pressurized propellant in its gaseous state to directly enter the valve thus leading to a faster expulsion of the liquid product.

25 **[0003]** The eduction pipe 55 can be made of silicone or a polyethylene. Silicone is preferred as it is more flexible than polyethylene, so that when the apparatus is used in a tilted position, the open pipe end will always be immersed in the liquid.

30

[0004] It is known in the art that liquefied propellants are denser than the liquid product to be dispensed so that the liquefied propellant is at the bottom of the container underneath the liquid product. As a consequence, the end piece of the suction pipe plunges into pure liquefied propellant only. This has the drawback that, upon actuation of the valve, the liquefied propellant is expelled rather than the liquid product.

[0005] To solve this problem, it is proposed to enclose the liquefied propellant in one or several reservoirs immersed in the liquid product. These reservoirs release the liquefied propellant to the gaseous phase upon actuation of the valve. Hence, the accidental loss of liquefied propellant through the suction pipe is avoided.

[0006] The reservoirs are made of a material that is able to absorb the pressurized liquefied propellant and release it in the gaseous phase. They can, for example, be made of polymeric materials like PVC or nylon. The shape of the reservoirs is not limited, although a spherical shape is preferred as it leads to less clogging of the tube or orifice.

[0007] The reservoirs may be used to hold optional propellant additives. However, the additives held in the reservoirs cannot be fully isolated from the liquid product as the additives will eventually be released into the liquid product, albeit slowly.

Claim:

Pressurized apparatus which includes a container containing a liquid product to be dispensed and a liquefied propellant stored in at least one reservoir immersed in the liquid product.

Fig.

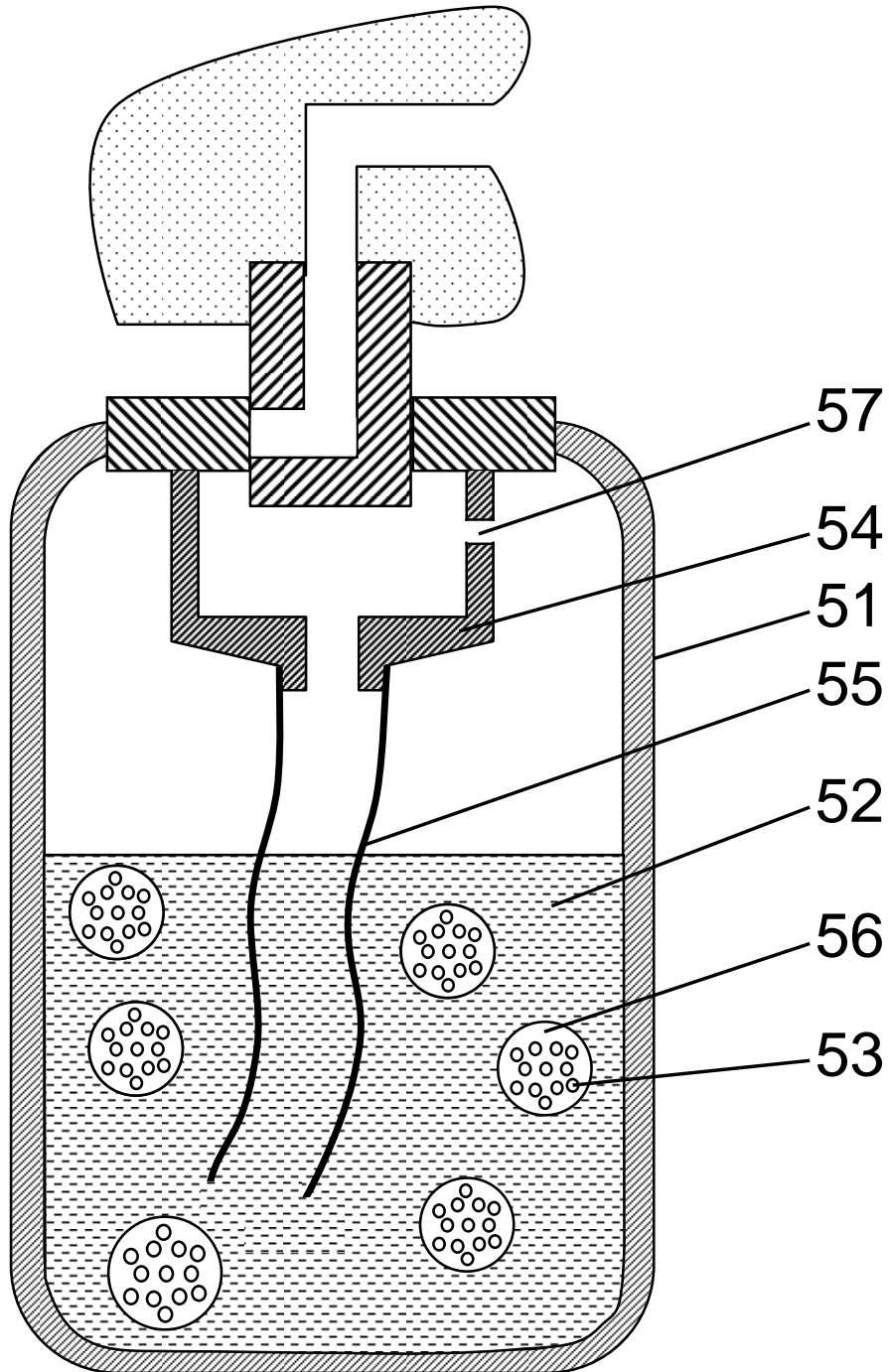

- (19) **European Patent Office**
- (12) **European Patent Application**
- (21) Application number: **04175746.2**
- (11) Publication number: **EP 1 798 231 A1**
- 5 (22) Date of filing: **15.11.2004**
- (43) Date of publication: **15.05.2006**
- (51) Int. Cl.: **B65D83/44**
- (71) Applicant: **Valvometrix**
- (72) Inventor: **Kühl, Molly**
- 10 (84) Designated Contracting states: **AT BE CH LI GB**

Metering valves for aerosol dispensers

15 **[0001]** A metering valve that enables the administration of drugs and pharmaceutical products in accurately measured doses is disclosed herein. The valve is made of a gas-permeable porous ceramic material in order to improve the aerosol properties.

20 **[0002]** The metering valve of the invention comprises a valve chamber of predetermined volume formed by a hollow body. The valve chamber is provided with an inlet which opens to the interior of the container on which it is mounted, so that a fluid product under pressure may enter the chamber. Additionally, the inlet of the valve is mounted with a HDPE tube which can bend as the container is tipped to take up the fluid product and through which the fluid product can enter the valve chamber.

25 **[0003]** The valve also has a movable stem with an outlet from which the fluid product is released from the valve to the atmosphere. When not in use, the outlet of the stem is closed. The metering is achieved by plugging the valve inlet by pushing down on the stem. The stem closes the valve inlet before opening the outlet to the atmosphere, thus allowing the expulsion of the fluid product located in the chamber only.

[0004] The metering valve material comprises a gas-permeable porous ceramic with a pore size of which can be freely adjusted by known techniques. Ceramic valves are particularly long lasting as they are made of a highly wear-resistant material.

- 5 [0005] The pore size of the ceramic material lies between $0.1 \mu\text{m}$ and $4 \mu\text{m}$. The pore size is preferably greater than $0.9 \mu\text{m}$ as the diffusion of a pressurized (400 to 500 kPa) propellant gas through the valve is then optimum for the aerosol properties.

10 [0006] It has been observed that when the pore size of the gas-permeable porous ceramic is greater than $2 \mu\text{m}$, the material becomes permeable to liquids, which can lead to leakage of liquid product through the valve when the device is tilted. When the pore size is greater than $4 \mu\text{m}$, the flow of gas diffusing through the valve is too high and a poor quality aerosol is obtained.

15 **Claim:**

Metering valve assembly for dispensing a liquid product stored under gas pressure comprising a metering valve and wherein the wall of the valve body is made of a gas-permeable ceramic porous material having a pore size comprised between $0.1 \mu\text{m}$ and $4 \mu\text{m}$.

20

Notes to the notice of opposition (EPO Form 2300)

Although the opposition form is not mandatory for the purpose of filing a notice of opposition, it specifies all the information required for such a notice to be admissible and hence facilitates the formulation and processing of the opposition. In stating and explaining the grounds for opposition, the opponent is free to comment as he wishes.

Explanatory notes to the various sections:

I. Patent opposed

Under **Patent No.** the number of the European patent against which opposition is filed (Rule 76(2)(b) EPC) must be given.

If known, the **application number and the date on which the Patent Bulletin mentions the grant** (Art. 97(3) EPC) should also be given. The latter makes it easier to monitor compliance with the opposition period.

The **title of the invention** must be given (Rule 76(2)(b) EPC); it should be indicated **as shown on the cover page of the printed patent specification** under item 54.

II. Proprietor of the patent

Where there are **several** patent proprietors, it is sufficient for the proprietor first named in the patent specification (under item 74) to be given.

III. Opponent

The **name, address and nationality** of the opponent and the **state** in which his residence or principal place of business is located must be given, in accordance with Rule 41(2)(c) EPC (Rule 76(2)(a) EPC). If the identity of the opponent has not been established by expiry of the opposition period, such deficiency can no longer be remedied (decision of the Technical Board of Appeal T 25/85, OJ EPO 1986, 81).

IV. Authorisation

If the opponent has appointed a **representative**, his name and the address of his place of business must be given, in accordance with Rule 41(2)(c) EPC (Rule 76(2)(d) EPC). If **several** professional representatives are appointed, only one representative to whom notification is to be made should be named. Any further representatives must be named in an annex (please put a cross in the appropriate box). In the case of an association of representatives, only the name and address of the association must be entered (see Rule 143(1)(h)).

of the EPC contracting states must be represented and act through his representative (Art. 133(2) EPC). Professional representation before the EPO may only be undertaken by professional representatives (Art. 134(1) EPC) or legal practitioners entitled to act as professional representatives (Art. 134(8) EPC).

Natural or legal persons having their residence or principal place of business within the territory of one of the EPC Contracting States may also be represented in opposition proceedings by an **employee**, who must, however, be authorised (Art. 133(3), first sentence, EPC). In this case notification will be made to the opponent (not the employee) unless a professional representative has also been authorised.

To avoid delaying the proceedings, any authorisation which has to be filed should if possible be enclosed with the opposition. Under Rule 152(1) EPC in conjunction with the decision of the President of the EPO dated 12 July 2007, listed professional representatives identifying themselves as such normally no longer need to file signed authorisations (cf. Special edition No. 3, OJ EPO 2007, L.1.). These are, however, required from legal practitioners and employees who are not professional representatives and are acting for the opponent under Articles 134(8) and 133(3), first sentence, EPC respectively. If they do not file an authorisation, the EPO will ask them to do so within a specified period. Failure to comply will result in any procedural steps performed by the practitioner or employee being deemed not to have been taken (Rule 152(6) EPC) – which means that the notice of opposition will be considered not to have been filed.

V. Statement of the extent to which the patent is opposed

The notice of opposition must contain a statement of the extent to which the European patent is opposed (Rule 76(2)(c) EPC). If the opposition is not filed against the patent as a whole (place a cross in the appropriate box), the number(s) of the claims (as in the patent specification) which the opponent considers to be affected by one or more of the grounds for opposition must be given.

VI. Grounds for opposition

The alleged grounds for opposition (Art. 100 EPC) must be indicated by a cross in the appropriate box(es).

Under the heading of non-patentability (Art. 100(a) EPC) the most frequently cited grounds for opposition are lack of novelty and lack of inventive step, for

otherwise gives the opponent ample scope for indicating other possible grounds for opposition. Under the heading “other grounds” the following Articles may be cited in the box provided: 52(1) and 57; 52(2); 53(a); 53(b); 53(c) EPC.

A full list of grounds for opposition is given in Article 100 EPC. The following in particular are not admissible grounds: lack of unity of invention (Art. 82 EPC), lack of clarity in the claims (Art. 84 EPC) and prior national rights (Art. 139(2) EPC).

For general information on grounds for opposition see Guidelines for Examination in the EPO, D-III, 5.

VII. Facts and arguments presented in support of the opposition

The notice of opposition must contain an indication of the facts and evidence presented in support of the opposition (Rule 76(2)(c) EPC) and, where documents are cited, an indication of the relevant part(s) (Guidelines D-IV, 1.2.2.1).

The facts, with the relevant arguments and evidence, in support of the opposition must be presented on a separate sheet enclosed as an annex to the Form (indicated by a pre-printed cross in the box).

The fact that the evidence is listed separately in Section IX does not anticipate the presentation of facts, evidence and arguments but merely makes for greater clarity and simplifies processing of the dossier. Section IX of the Form (Evidence presented) may of course always be referred to in this presentation.

Where documents are cited in shortened form, the rules set out in the Guidelines B-X, 9.1 should be followed.

VIII. Other requests

This section may be used for example to request oral proceedings or a file inspection.

IX. Evidence

Published documents cited as evidence (e.g. patent specifications) must be entered under “Publications” in the spaces provided – preferably in order of importance. They should be cited in the manner described in Guidelines B-X, 9.1.

Opponents should also indicate the parts of the document on which the opposition is based (this information has to be given anyway in the statement of facts and arguments – see notes to Section VII above).

Other evidence (e.g. witnesses, affidavits, company brochures, test or expert reports) must be cited under “Other evidence” (for public prior use: place, time, nature – see Guidelines D-V, 3.1.2; D-IV, 1.2.2.1(v):

room, the evidence can simply be listed, with an indication of where in the statement of grounds the relevant particulars appear (e.g. “Witness ..., page 5”).

Documents cited by a party to opposition proceedings must be filed (including publications already cited in the European patent specification) with the notice of opposition or other written submission. This will avoid an invitation from the EPO for subsequent filing thereof. If they are neither enclosed nor filed in due time on invitation, the EPO may ignore any arguments based on them (Rule 83 EPC).

X. Payment of opposition fee

The opposition fee must be paid within the opposition period. Notice of opposition is not deemed to have been filed until the opposition fee has been paid (Art. 99(1) EPC). With regard to what constitutes the date to be considered as the date on which payment is made, see Article 7 of the Rules relating to Fees and the guidance on payment methods in the Official Journal.

XI. List of documents enclosed

Please indicate which documents are enclosed by crossing the relevant box.

XII. Signature

If the opponent is a legal person and the notice of opposition is not signed by the representative, it must be signed:

- (a) either by a person entitled to sign under the law or the opponent’s statute, articles of association or the like, with an **indication of the capacity of the person doing so**, e.g. Geschäftsführer, Prokurist, Handlungsbevollmächtigter; chairman, director, company secretary; directeur, fondé de pouvoir (Art. 133(1) EPC), in which case no authorisation need be filed;
- (b) or by another employee of the opponent, provided the latter’s principal place of business is in a contracting state (Art. 133(3), first sentence; Rule 152(1) EPC), in which case an authorisation must be filed.

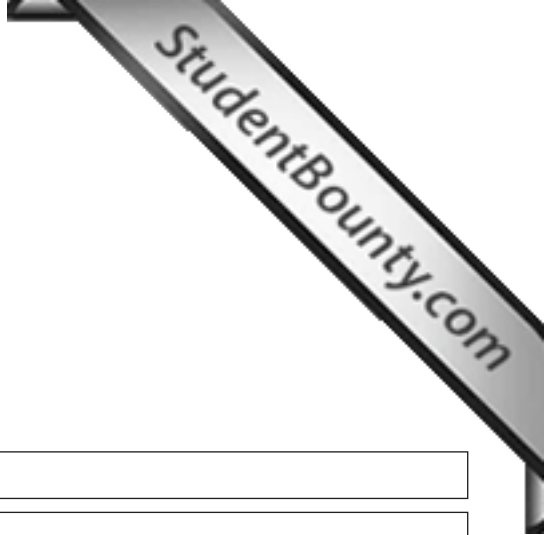

Notice of opposition to a European patent

I. Patent opposed

Patent No.

Application No.

Date of mention of the grant in the European Patent Bulletin (Art. 97(3), Art. 99(1) EPC)

Title of the invention

II. Proprietor of the patent

first named in the patent specification

Opponent's or representative's reference (max. 15 keystrokes)

III. Opponent

Name

Address

State of residence or of principal place of business

Nationality

Telephone/Fax

Multiple opponents (see additional sheet)

IV. Authorisation

1. Representative (name only one representative or name of association of representatives to whom notification is to be made)

Address of place of business

Telephone/Fax

Additional representative(s) on additional sheet/see authorisation

2. Name(s) of employee(s) of the opponent authorised to act in these opposition proceedings under Art. 133(3) EPC

Authorisation(s) to 1./2. not considered necessary

has/have been registered under No.

is/are enclosed

V. Opposition is filed against

• the patent as a whole

• claim(s) No(s).

VI. Grounds for opposition:

Opposition is based on the following grounds:

(a) the subject-matter of the European patent opposed is not patentable (Art. 100(a) EPC) because:

• it is not new (Art. 52(1); Art. 54 EPC)

• it does not involve an inventive step (Art. 52(1); Art. 56 EPC)

• patentability is excluded on other grounds, i.e. Article

(b) the patent opposed does not disclose the invention in a manner sufficiently clear and complete for it to be carried out by a person skilled in the art (Art. 100(b) EPC; see Art. 83 EPC).

(c) the subject-matter of the patent opposed extends beyond the content of the application/of the earlier application as filed (Art. 100(c) EPC, see Art. 123(2) EPC).

VII. Facts (Rule 76(2)(c) EPC)

presented in support of the opposition are submitted herewith on a separate sheet (annex 1)

VIII. Other requests:

IX. Evidence presented

Evidence is enclosed
will be filed at a later date

A. Publications:

1
Particular relevance (page, column, line, fig.):

2
Particular relevance (page, column, line, fig.):

3
Particular relevance (page, column, line, fig.):

4
Particular relevance (page, column, line, fig.):

5
Particular relevance (page, column, line, fig.):

6
Particular relevance (page, column, line, fig.):

Continued on additional sheet

B. Other evidence

Continued on additional sheet

Please do not use

X. Payment of the opposition fee is made

- as indicated in the enclosed voucher for payment of fees and costs (EPO Form 1010)
- via EPO Online Services

XI. List of documents

Enclosure No.

- 0 Form for notice of opposition
- 1 Facts (see VII.)
- 2 Copies of documents presented as evidence (see IX.)
 - a Publications
 - b Other documents
- 3 Signed authorisation(s) (see IV.)
- 4 Voucher for payment of fees and costs (see X.)
- 5 Additional sheet(s)
- 6 Other

Number of sheets

Please specify here:

XII. Signature of opponent or representative

Place

Date

Signature

Name (block capitals)

In case of legal persons, signatory's position within company