

EUROPEAN QUALIFYING EXAMINATION 2012

Paper B(E/M)

Electricity / Mechanics

This paper comprises:

- | | |
|--|----------------------|
| * Description of the Application | 2012/B(E/M)/EN/1-4 |
| * Claims | 2012/B(E/M)/EN/5-6 |
| * Drawings of the Application | 2012/B(E/M)/EN/7-8 |
| * Communication
(including Annex, copy of the claims) | 2012/B(E/M)/EN/9-13 |
| * Document D1 | 2012/B(E/M)/EN/14-15 |
| * Drawing Document D1 | 2012/B(E/M)/EN/16 |
| * Document D2 | 2012/B(E/M)/EN/17 |
| * Drawing Document D2 | 2012/B(E/M)/EN/18 |
| * Client's Letter | 2012/B(E/M)/EN/19-20 |

Description of the Application

5 [001] The present invention relates to self-cooling barrels. Such barrels employ a zeolite-water adsorption cooling process. Zeolites are minerals which strongly attract water and trap it in their microporous structure, i.e. they “adsorb” water. After use, the cooling capacity of these barrels is restored in a regeneration process. The principles of both processes are explained in the following with reference to Figs. 1a and 1b.

10 [002] An adsorption chamber 2 contains a zeolite 1 and an evaporation chamber 4 contains water 3. A valve 6 is provided for opening and closing a passage in a wall 5 separating the chambers 2 and 4 from each other. The valve 6 comprises a valve handle 7.

15 [003] To start the adsorption cooling process shown in Fig. 1a, the passage is opened by pulling the valve handle 7. The zeolite 1 attracts water, which evaporates in the evaporation chamber 4. Due to the evaporation, the water 3 remaining in the evaporation chamber 4 cools down and may even freeze to ice. The zeolite 1 adsorbs the water vapour (represented by arrows), which condenses in the zeolite. Due to the condensation, the zeolite 1 heats up.

20 [004] During the subsequent regeneration process shown in Fig. 1b, the zeolite 1 in the adsorption chamber 2 is heated (represented by zigzag arrows). The previously adsorbed water evaporates from the zeolite 1. The water vapour re-enters the colder evaporation chamber 4 where it condenses. After completion of the regeneration process, the passage is closed by pushing the valve handle 7.

[005] A prior art self-cooling barrel 10 marketed by the applicant under the brand name "Killbenny" is shown in cross section in Fig. 2.



5 [006] Like a conventional barrel it comprises a liquid container 20. Liquid, for example beer, can be poured into the container 20 via a filling neck 21 and discharged via a discharge opening 22. The filling neck 21 is closed by a screw cap 23. The discharge opening 22 is closed by a plug 24 which can be replaced by a tap (not shown) in order to discharge the liquid. The top portion of the barrel 10 has a circumferential rim which is rolled inwardly. The rim has a form and dimensions which correspond to those of a circumferential recess at the bottom of the barrel so that several barrels can be stably stacked on top of each other.

10 [007] A zeolite 11 is held by a wire mesh 19 in an adsorption chamber 12 at the bottom of the barrel 10. An evaporation chamber 14 is arranged between the adsorption chamber 12 and the container 20. A first wall 15 separates the adsorption chamber 12 from the evaporation chamber 14. The adsorption chamber 12 may communicate with the evaporation chamber 14 via a passage in the first wall 15. The passage can be
15 opened and closed by means of a valve 16. The valve 16 comprises a valve handle 17. A second wall 18, which is part of the container wall, separates the evaporation chamber 14 from the liquid to be cooled. Inside the evaporation chamber 14 the second wall 18 is covered by a layer 13 of hygroscopic material, e.g. spongy material, in which water is stored.

20 [008] To cool down the liquid in the container 20, the passage is opened by pushing the valve handle 17. Water evaporates from the layer 13. Water vapour passes through the passage in the first wall 15 and enters the adsorption chamber 12, where it is adsorbed by the zeolite 11. During this adsorption cooling process, the zeolite 11 heats up and the
25 water remaining in the layer 13 freezes to ice. The ice on the second wall 18 cools the liquid at the bottom of the container 20, which is the first to be discharged. To facilitate heat dissipation from the zeolite 11 into the environment, it is recommended to stand the barrel 10 on a latticed and/or metallic support during use.



[009] After use, the container 20 is cleaned and refilled with cold liquid via the filling neck 21. The zeolite 11 is then heated by placing the barrel 10 in an oven. Water vapor is expelled from the zeolite 11 and passes via the open passage into the evaporation chamber 14, where it condenses in the layer 13 next to the cold liquid. After completion
5 of this regeneration process the passage is closed by pulling the valve handle 17.

[010] This prior art barrel 10 presents some drawbacks. The efficiency of the adsorption cooling process depends on the effective heat exchange surface of the evaporation chamber 14. This surface is formed by the second wall 18 and is relatively small.
10 Furthermore, the valve 16 protrudes from the side of the barrel 10. This arrangement risks the valve being accidentally opened, e.g. during transport.

[011] The self-cooling barrel according to the present invention provides improvements over the prior art barrel with regard to the efficiency of the adsorption cooling process
15 and the arrangement of the valve.

[012] According to claim 1, the second wall separating the evaporation chamber from the container comprises at least part of a side wall of the container. Thus a larger heat exchange surface for cooling the liquid in the container can be achieved.



[013] The dependent claims define further details of the invention. In order to further increase the efficiency of the adsorption cooling process, the configuration of the adsorption chamber may be optimised as follows. Preferably, the adsorption chamber has a U-shaped cross section and surrounds the evaporation chamber so that:

- 5 - the adsorption chamber insulates the evaporation chamber; and
 - the zeolite can be arranged to be only at the side of the barrel, from where heat can be efficiently dissipated into the ambient air. If there is no zeolite arranged at the bottom of the barrel, the efficiency of the adsorption cooling process is independent of the temperature, structure and material of the support on which the barrel stands. If
- 10 furthermore the evaporation chamber and thus the first wall extend along substantially the full height of the container, the valve may advantageously be arranged in the top portion of the barrel instead of protruding from the side of the barrel.

[014] An embodiment of the invention will now be described with reference to Fig. 3
15 which shows a self-cooling barrel according to the invention in cross section.

[015] The barrel 30 comprises a liquid container 40 having a filling neck 41 closed by a screw cap 43 and a discharge opening 42 closed by a plug 44. The top portion and the bottom of the barrel 30 comprise corresponding structures allowing a plurality of such
20 barrels to be stably stacked on top of each other.

[016] A first wall 35 separates the evaporation chamber 34 from the adsorption chamber 32. A valve 36 comprising a valve handle 37 is arranged in the top portion of the barrel 30. A passage in the first wall 35 can be opened by pulling the valve
25 handle 37 upwards. Inside the adsorption chamber 32, a zeolite 31 is held at a distance from the first wall 35 by a wire mesh 39. The container wall forms a second wall 38 which separates the evaporation chamber 34 from the liquid to be cooled. Inside the evaporation chamber 34, the second wall 38 is covered by a layer 33 of hygroscopic material, in which water is stored.



Claims

1. A self-cooling barrel (30) comprising
 - a container (40) for liquid to be cooled,
 - an adsorption chamber (32) containing a zeolite (31),
 - an evaporation chamber (34) containing water,
 - a first wall (35) separating the adsorption chamber (32) from the evaporation chamber (34),
 - a valve (36) arranged to open and close a passage in the first wall (35), and
 - a second wall (38) for separating the evaporation chamber (34) from the liquid to be cooled,characterised in that
the second wall (38) comprises at least part of a side wall of the container (40).

2. A self-cooling barrel (30) according to claim 1, comprising
a layer (33) of hygroscopic material for storing the water, the layer (33) being
arranged in the evaporation chamber (34) on the second wall (38).

3. A self-cooling barrel (30) according to claim 1 or 2, comprising
a wire mesh (39) for holding the zeolite (31) at a distance from the first wall (35), the
wire mesh (39) being arranged in the adsorption chamber (32).

4. A self-cooling barrel (30) according to any one of the preceding claims, wherein
the second wall (38) further comprises a bottom wall of the container (40).

5. A self-cooling barrel (30) according to claim 4, wherein
the adsorption chamber (32) has a U-shaped cross section and surrounds the
evaporation chamber (34).



6. A self-cooling barrel (30) according to claim 5, wherein the evaporation chamber (34) extends along substantially the full height of the container (40) and wherein there is no zeolite arranged at the bottom of the barrel (30).
7. A self-cooling barrel (30) according to claim 6, wherein the valve (36) is arranged in the top portion of the barrel (30).
8. A self-cooling barrel (30) according to any one of the preceding claims, wherein the top portion and bottom of the barrel (30) have corresponding structures configured so that a plurality of such barrels can be stably stacked on top of each other.



Drawings of the Application

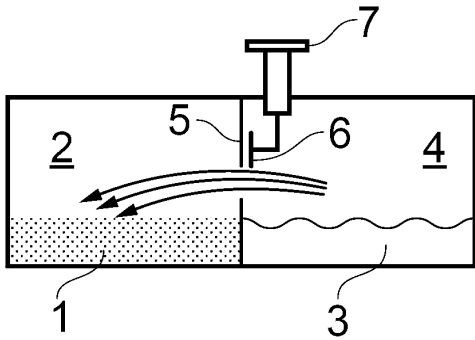

FIG. 1a

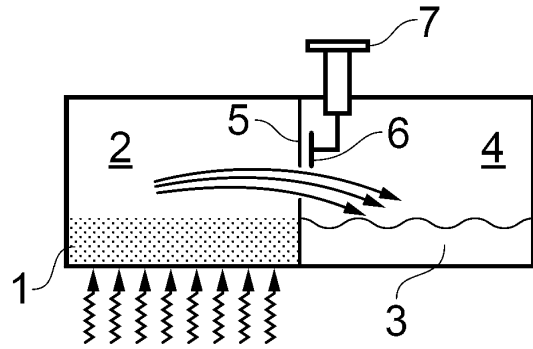

FIG. 1b

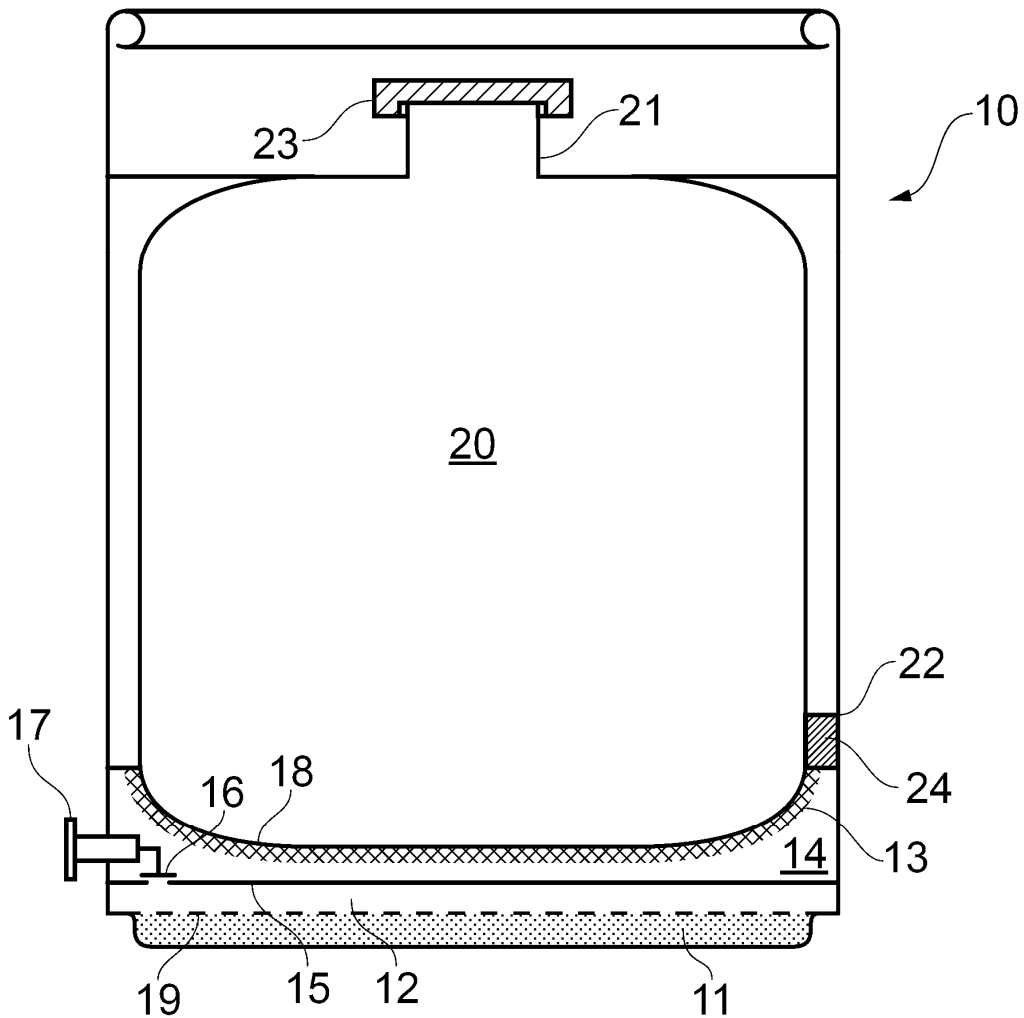

FIG. 2



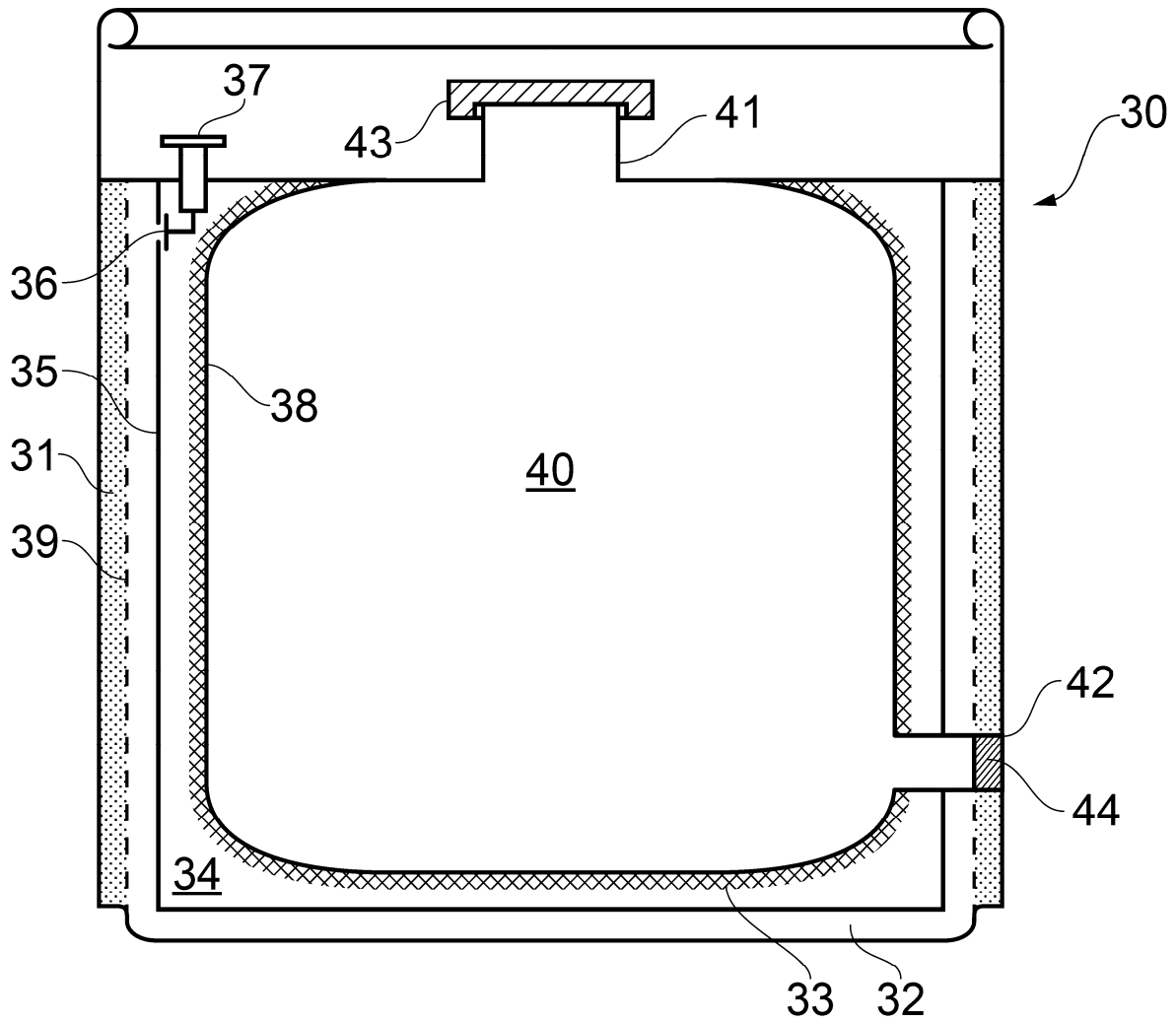

FIG. 3

Communication according to Art. 94(3) EPC

The examination is based on the application documents as originally filed. A copy of the claims as originally filed is annexed to this communication (see annex).

Reference is made to the following prior art:

The Killbenny barrel (hereinafter referred to as "KB") as shown in Fig. 2 and described in Paragraphs 5 to 7 of the application; documents D1 and D2 which were published before the priority date of the present application.

1. The application does not meet the requirements of Art. 52(1) EPC since the subject-matter of independent claim 1 is not new in the sense of Art. 54(1), (2) EPC with regard to KB.

KB is a self-cooling barrel (10) comprising

- a container (20) for liquid to be cooled,
- an adsorption chamber (12) containing a zeolite (11),
- an evaporation chamber (14) containing water,
- a first wall (15) separating the adsorption chamber (12) from the evaporation chamber (14),
- a valve (16) arranged to open and close a passage in the first wall (15), and
- a second wall (18) for separating the evaporation chamber (14) from the liquid to be cooled.

Furthermore, the curved portion of the second wall (18), which extends up to the height of the discharge opening (22), is considered to be part of the side wall of the container (20). Therefore the second wall (18) comprises part of a side wall of the container (20).



2. The subject-matter of dependent claims 2 to 4 and 8 is not new, since the additional features of these claims are known from KB.

KB comprises a layer (13) of hygroscopic material as defined in claim 2.

KB comprises a wire mesh (19) as defined in claim 3.

In KB, the second wall (18) further comprises a bottom wall of the container (20) as defined in claim 4.

KB comprises structures as defined in claim 8.

3. Furthermore, the subject-matter of dependent claim 5 does not involve an inventive step in the sense of Art. 56 EPC.

The closest prior art is the self-cooling barrel KB.

The subject-matter of claim 5 differs from KB in that the adsorption chamber has a U-shaped cross section and surrounds the evaporation chamber.

Such a configuration of the adsorption chamber is described in D1 (see par. 3 and the drawing). According to D1 this configuration makes the adsorption cooling process highly efficient (see par. 6).

It is therefore obvious to integrate the above identified features into KB in order to solve the problem of improving the efficiency of the adsorption cooling process.

4. It is noted that the additional features of claims 6 and 7 are per se known from D2 (see Fig. 1):
 - The evaporation chamber (204) extends along the full height of the container (cooling space 216) and there is no zeolite arranged at the bottom of the box (200);
 - the valve (206) is arranged in the top portion of the box (200).



5. Claim 6 is not clear (Art. 84 EPC).

The negative limitation "there is no zeolite arranged at the bottom of the barrel" is not admissible because it can be more clearly defined in terms of an alternative positive feature without unduly limiting the scope of the claim (see Guidelines C-III, 4.20, second paragraph).

6. The applicant is invited to file a new set of claims which takes account of the above objections.



Annex

Claims as originally filed

1. A self-cooling barrel (30) comprising
 - a container (40) for liquid to be cooled,
 - an adsorption chamber (32) containing a zeolite (31),
 - an evaporation chamber (34) containing water,
 - a first wall (35) separating the adsorption chamber (32) from the evaporation chamber (34),
 - a valve (36) arranged to open and close a passage in the first wall (35), and
 - a second wall (38) for separating the evaporation chamber (34) from the liquid to be cooled,characterised in that
the second wall (38) comprises at least part of a side wall of the container (40).
2. A self-cooling barrel (30) according to claim 1, comprising a layer (33) of hygroscopic material for storing the water, the layer (33) being arranged in the evaporation chamber (34) on the second wall (38).
3. A self-cooling barrel (30) according to claim 1 or 2, comprising a wire mesh (39) for holding the zeolite (31) at a distance from the first wall (35), the wire mesh (39) being arranged in the adsorption chamber (32).
4. A self-cooling barrel (30) according to any one of the preceding claims, wherein the second wall (38) further comprises a bottom wall of the container (40).
5. A self-cooling barrel (30) according to claim 4, wherein the adsorption chamber (32) has a U-shaped cross section and surrounds the evaporation chamber (34).



6. A self-cooling barrel (30) according to claim 5, wherein the evaporation chamber (34) extends along substantially the full height of the container (40) and wherein there is no zeolite arranged at the bottom of the barrel (30).
7. A self-cooling barrel (30) according to claim 6, wherein the valve (36) is arranged in the top portion of the barrel (30).
8. A self-cooling barrel (30) according to any one of the preceding claims, wherein the top portion and bottom of the barrel (30) have corresponding structures configured so that a plurality of such barrels can be stably stacked on top of each other.



Document D1: Barrel Cooler

5 [001] The barrel cooler described below can cool a barrel by an adsorption cooling process. Such a process does not require electric power and is therefore ideal for barbecues. Conveniently, a barrel to be cooled or returned when empty can be transported independently of the barrel cooler.

10 [002] The barrel cooler and a conventional 20-litre beer barrel 100, which has been placed into the cooler from above, are shown in the drawing in cross section. The barrel cooler surrounds the lower portion of the barrel 100 up to the height of the discharge opening 112 of the beer container 110. This allows a tap (not shown) to be introduced into the discharge opening 112 whilst the barrel is being cooled.

15 [003] The barrel cooler comprises an evaporation chamber 104 that surrounds the lower portion of the barrel 100. An adsorption chamber 102 having a U-shaped cross section surrounds the evaporation chamber 104. A valve 106 is provided for opening and closing a passage in a first wall 105, which separates the chambers 102 and 104 from each other. The valve 106 has a valve handle 107.

20 [004] Inside the evaporation chamber 104, a layer 103 of hygroscopic material in which water is stored, covers a second wall 108. The second wall 108 is in contact with the bottom of the barrel 100. Inside the adsorption chamber 102, a zeolite 101 is held at a distance from the first wall 105 by a wire mesh 109.

25 [005] When the passage is opened by pulling the valve handle 107 upwards, water evaporates from the layer 103 and is adsorbed by the zeolite 101 which heats up. The water remaining in the layer 103 freezes and cools the barrel 100.



[006] The particular configuration of the adsorption chamber makes the adsorption cooling process highly efficient because:

- the hot zeolite 101 can give off heat to the environment and thus efficiently adsorb water; and
- 5 - the adsorption chamber 102 insulates the evaporation chamber 104 from the environment thereby maximising the cooling capacity available for cooling the beer in the container 110.

[007] After use the barrel cooler is connected to an electric power supply (not shown) in order to restore its cooling capacity. The wire mesh 109, which is configured as an electric resistance heater, heats up the zeolite 101. Water vapour is then expelled from the zeolite 101 and condenses in the colder evaporation chamber 104. Finally the passage is closed by pushing the valve handle 107 downwards and the barrel cooler is disconnected from the electric power supply. The barrel cooler is now ready to be used
15 again.



Drawing Document D1

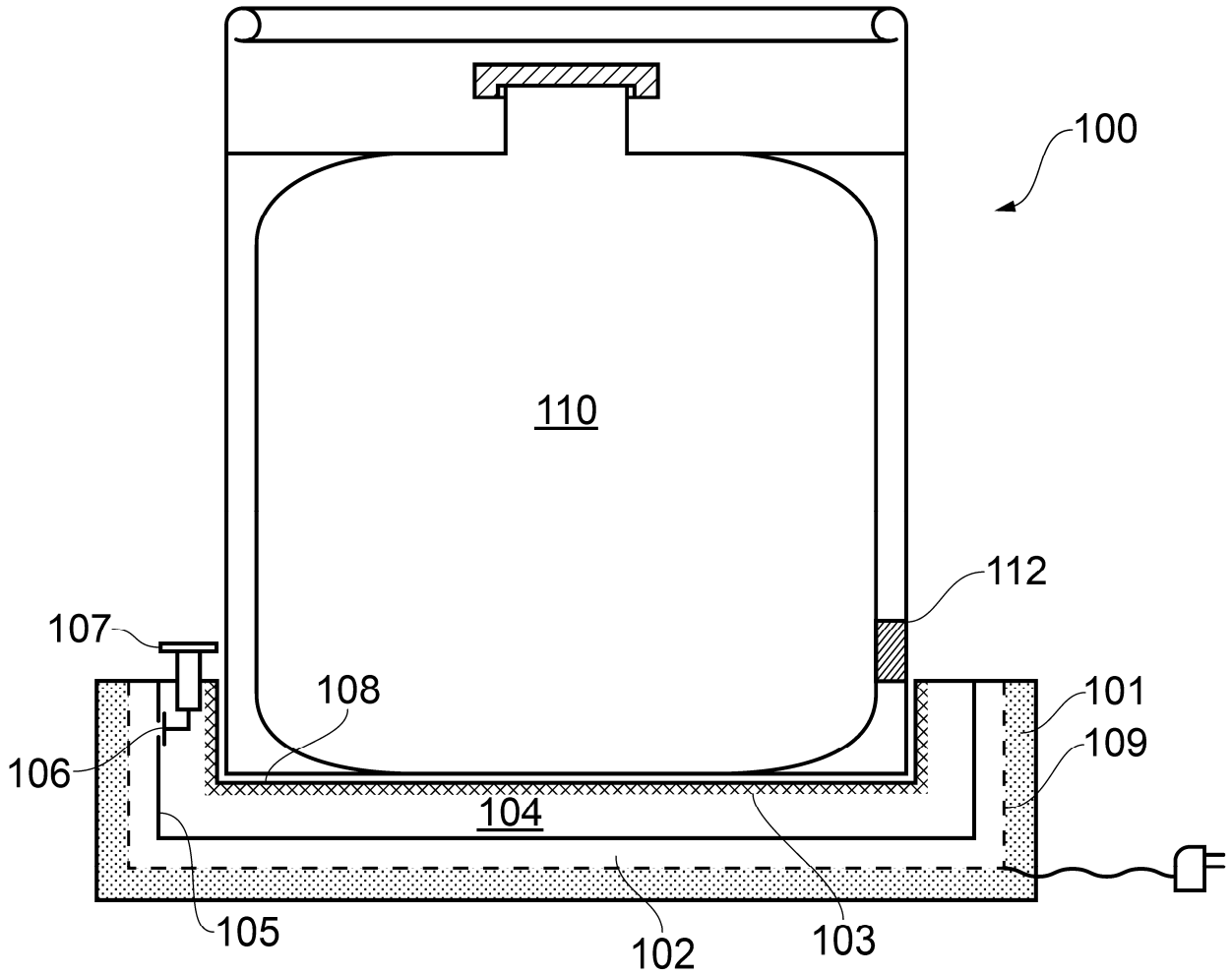

Document D2: Single-use cooling and heating box

[001] The present invention relates to a single-use box which, by means of adsorption technology, can cool the content of a cooling space and at the same time heat the content of a heating space. The cooling space contains, for example, a beverage and the heating space, for example, a soup. The box is ideal for military and outdoor activities where electric power is not available. Being intended to be used only once, the box is designed to have minimal production costs.

[002] Fig. 1 is a cross-sectional view of a cooling and heating box 200 according to the present invention.

[003] The box 200 comprises an evaporation chamber 204 defining a cylindrical cooling space 216. The evaporation chamber 204 is filled with water 203. The evaporation chamber 204 communicates with an adsorption chamber 202 via a passage which can be opened and closed by means of a valve 206. The valve 206 comprises a valve handle 207. The adsorption chamber 202 defines a cylindrical heating space 217. The adsorption chamber 202 is filled with a zeolite 201.

[004] Both chambers 202 and 204 are surrounded by a thermally insulating jacket 219 and closed by a thermally insulating cover 220. The cover 220 comprises a recess configured to accommodate the valve handle 207. The valve handle 207 does not protrude above the cover 220 so that several boxes can be stacked for transport.

[005] When the passage is opened by pulling the valve handle 207 upwards, water evaporates from the evaporation chamber 204 and is adsorbed by the zeolite 201. The cold water remaining in the evaporation chamber 204 cools the contents of the cooling space 216. The hot zeolite 201 in the adsorption chamber 202 heats the contents of the heating space 217. After piercing the cover 220, for example with a straw, the contents of the heating and cooling spaces can be consumed.



Drawing Document D2

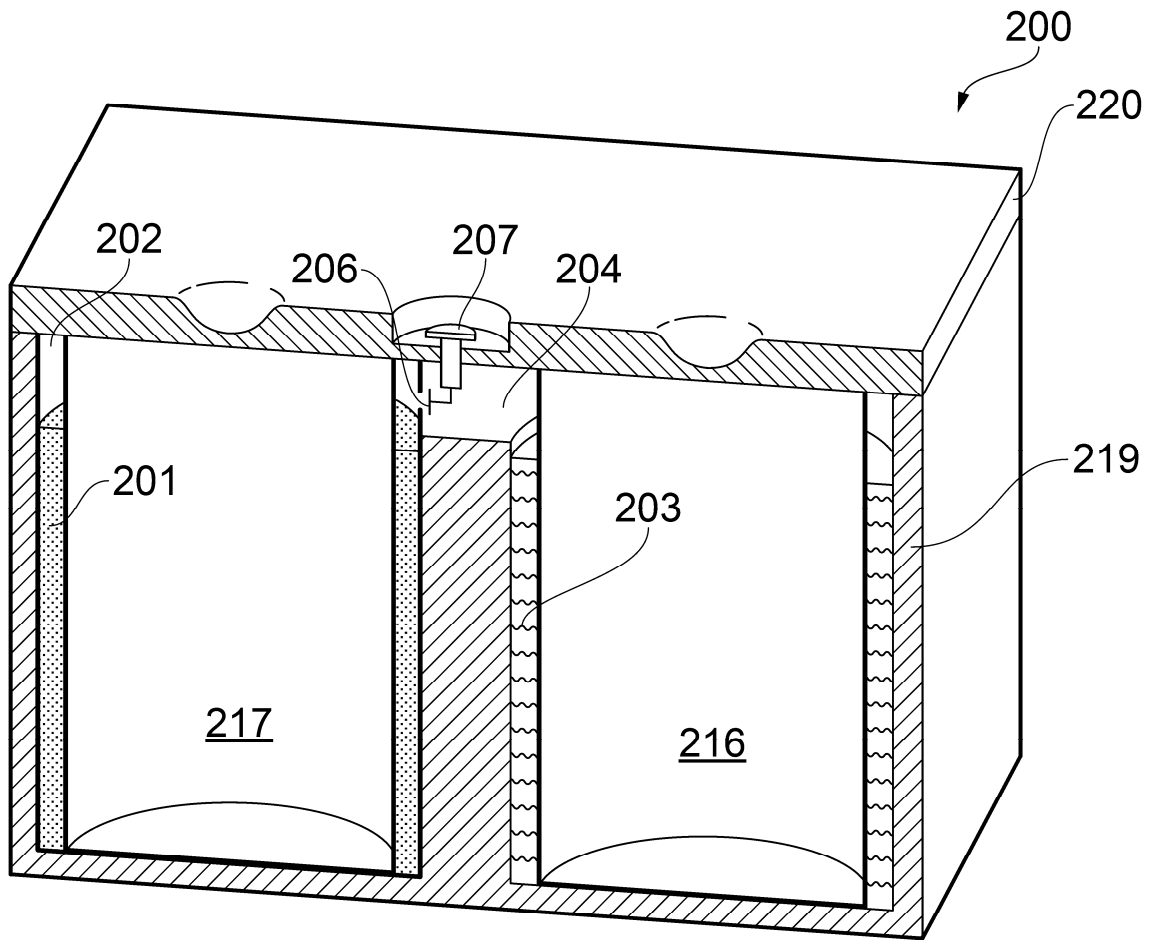

FIG. 1

Client's letter

Dear Mr. Carl Berg,

Thank you for sending us the communication issued by the European Patent Office.

We would like to point out that, as described in paragraph 13 of the application, the particular configuration of the adsorption chamber according to claims 5 and 6 improves the efficiency of the adsorption cooling process considerably. In order to obtain this effect it is not necessary for the evaporation chamber and thus the surrounding adsorption chamber to extend along the full height of the container. Chambers not extending to this height can also provide sufficiently large heat exchange surfaces.

We consider that a combination of the above mentioned features of the adsorption chamber is not suggested by the available prior art even if the features of claim 5 and those of claim 6 might be known per se from D1 and D2, respectively.

Since there is no zeolite at the bottom of our new barrels, further advantages during transport and use can be realised:

- The overall height of the barrels is reduced which makes it easier to handle them, in particular to stack them; and
- a barrel can be stacked on top of another barrel during the adsorption cooling process, i.e. when the zeolite gets hot, without heating the other barrel.

By contrast, when our Killbenny barrels are stacked (see sketch below) and the upper one is in use, the hot zeolite at the bottom of this barrel transmits heat to the top portion of the barrel underneath. For some customers, we drilled ventilation holes in the top portion of the barrels (as shown in the sketch). The holes allow air circulation and thus promote heat dissipation. However, they weaken the structure of the barrels so that a maximum of three barrels can be stacked on top of each other without the lowermost barrel becoming deformed.



Please amend the claims taking into account the above considerations and the objections raised by the Examiner.

Yours sincerely,
Guy Ness

