

EUROPEAN QUALIFYING EXAMINATION 2010

Paper B(E/M)

Electricity / Mechanics

This paper comprises:

- | | |
|----------------------------------|----------------------|
| * Description of the Application | 2010/B(E/M)/EN/1-5 |
| * Claims | 2010/B(E/M)/EN/6-7 |
| * Drawings of the Application | 2010/B(E/M)/EN/8-9 |
| * Communication | 2010/B(E/M)/EN/10-12 |
| * Document D1 | 2010/B(E/M)/EN/13-15 |
| * Drawings Document D1 | 2010/B(E/M)/EN/16-17 |
| * Document D2 | 2010/B(E/M)/EN/18-19 |
| * Drawing Document D2 | 2010/B(E/M)/EN/20 |
| * Document D3 | 2010/B(E/M)/EN/21-23 |
| * Drawings Document D3 | 2010/B(E/M)/EN/24-25 |
| * Client's Letter | 2010/B(E/M)/EN/26 |
| * Working copy | |

Description of the Application

[001] The present invention relates to bird feeders.

5 [002] Bird feeders are known which have rotatable guards in order to prevent animals other than birds from gaining access to the food. In trying to cross the guard, an animal, e.g. a squirrel, causes the guard to rotate. The sudden rotation of the guard surprises the squirrel, so that it slips or jumps off the guard. Document D3 discloses such bird feeders.

10

[003] A drawback with these known bird feeders is that they are often ineffective. Squirrels can learn to cross the guards without causing them to rotate and can then access the food.

15 [004] It is an object of the present invention to provide bird feeders which overcome this drawback. This object is achieved by the subject matter of the attached claims.

[005] Brief description of the drawings:

Fig. 1 is a cross section of a bird feeder according to a first embodiment of the invention.

20 Fig. 2 is a cross section of a bird feeder according to a second embodiment of the invention.

[006] The bird feeder 1 shown in Fig. 1 comprises a feeding unit 2. The feeding unit 2 comprises a food container 3 and a food tray 5 from which birds can eat food. The food
25 container 3 has holes 4 through which food is supplied to the food tray 5. The food container 3 further has a screw lid 6 which enables the food container to be refilled.

[007] A rod 7 is fixed at one end to the upper surface of the screw lid 6 and at its other end to a ring 10. The ring 10 allows the bird feeder 1 to be suspended.

5 [008] The bird feeder 1 further comprises a rotatable guard 9. The guard 9 comprises a cone shaped shield 9a for protecting the food, a hollow cylindrical portion 9b extending downwards from the centre of the shield, and a gear wheel 9c fixed to the hollow cylindrical portion. The hollow cylindrical portion 9b is rotatably mounted on the rod 7. The guard 9 is supported on the screw lid 6 by a washer 11 and a spring 14 which are also mounted on the rod 7.

10 [009] The bird feeder 1 further comprises an electric motor 13, a switch 12 for activating the electric motor, and a battery (not shown) for energising the electric motor. The electric motor 13 and the switch 12 are mounted on the screw lid 6. The electric motor 13 has a toothed motor shaft 15 which engages with the gear wheel 9c of the guard 9. The electric motor 13 can thus rotate the guard 9.

15 [010] Fig. 1 shows the bird feeder 1 when no weight is applied to the shield 9a. When a weight is applied to the shield 9a, the guard 9 slides on the rod 7 in the direction of the arrow A. The hollow cylindrical portion 9b presses on the washer 11 and the spring 14 is compressed. When the weight exceeds a predetermined value, the washer 11 presses on the switch 12, thereby activating the electric motor 13. Driven by the electric motor 13, the guard 9 accelerates rapidly and rotates relative to the feeding unit 2. When the weight is no longer applied to the shield 9a, the spring 14 extends and pushes the washer 11 and the guard 9 back to their positions shown in Fig. 1. The washer 11 no longer presses on the switch 12 and the electric motor 13 is off.

20

25

[011] When a squirrel whose weight exceeds the predetermined value tries to cross shield 9a, it is surprised by the sudden rotation of the guard 9 and slips or jumps off the shield. If the predetermined value is chosen to be 250 g, most squirrels cannot cross the shield without the electric motor being activated. A guard rotation speed of 30 - 35
5 revolutions per minute is suitable to cause most squirrels to slip or jump off the shield. Even when the guard is rotating at such speeds, birds standing on the food tray can continue to feed, because the feeding unit does not rotate with the guard.

[012] Although Fig. 1 shows a guard having a cone shaped shield, the shield may have
10 any other shape which is suitable for protecting the food, such as a hemi-spherical shape or a disc shape.

[013] Fig. 2 shows a bird feeder 21 according to a second embodiment of the invention. The bird feeder 21 comprises a feeding unit 22 having a food tray 25.
15

[014] The bird feeder 21 further comprises a rod 27 and a base plate 28. The rod 27 is fixed at one end to the lower surface of the feeding unit 22 and at its other end to the base plate 28. The bird feeder 21 can be mounted on a pole (not shown) which is fixed to the lower surface of the base plate 28, for example by means of screws.
20

[015] The bird feeder 21 further comprises a rotatable guard 29. The guard 29 comprises a disc shaped shield 29a for protecting the food, a hollow cylindrical portion 29b extending downwards from the centre of the shield, and a gear wheel 29c fixed to the hollow cylindrical portion. The hollow cylindrical portion 29b is rotatably
25 mounted on the rod 27. The guard 29 is supported on the base plate 28 by a washer 31 and a spring 34 which are also mounted on the rod 27.

[016] The bird feeder 21 further comprises an electric motor 33, a switch 32 for activating the electric motor, and a battery (not shown) for energising the electric motor. The electric motor 33 and the switch 32 are mounted on the base plate 28. The electric motor 33 has a toothed motor shaft 35 which engages with the gear wheel 29c of the guard 29. The electric motor 33 can thus rotate the guard 29.

[017] Fig. 2 shows the bird feeder 21 when no weight is applied to the shield 29a. When a weight is applied to the shield 29a, the guard 29 slides on the rod 27 in the direction of the arrow A. The hollow cylindrical portion 29b presses on the washer 31 and the spring 34 is compressed. When the weight exceeds a predetermined value, the washer 31 presses on the switch 32, thereby activating the electric motor 33. Driven by the electric motor 33, the guard 29 accelerates rapidly and rotates relative to the feeding unit 22. When the weight is no longer applied to the shield 29a, the spring 34 extends and pushes the washer 31 and the guard 29 back to their positions shown in Fig. 2. The washer 31 no longer presses on the switch 32 and the electric motor 33 is off.

[018] When a squirrel whose weight exceeds the predetermined value tries to cross the shield 29a, it is surprised by the sudden rotation of the guard 29 and slips or jumps off the shield.

[019] Although Fig. 2 shows a guard having a disc shaped shield, the shield may have any other shape which is suitable for protecting the food, such as a hemi-spherical shape or a cone shape. The feeding unit of the bird feeder of the second embodiment may additionally comprise a food container similar to that shown in Fig. 1

[020] In both embodiments of the invention, the spring and the switch act as a weight sensor which detects whether a weight applied to the guard exceeds a predetermined value and activates the electric motor under this condition. Instead of the spring and the switch, any other conventional weight sensor for sensing a weight applied to the guard could be used, provided it is configured to activate the electric motor when the weight exceeds a predetermined value. Furthermore, instead of a gear transmission, a belt or chain transmission may be used for driving the guard. These alternative transmissions are well-known to the skilled person. The bird feeders of the invention may additionally comprise a motor speed controller for adjusting the guard rotation speed.

Claims

1. A bird feeder (1) comprising:
 - a feeding unit (2) for holding bird food;
 - a guard (9) comprising a cone shaped shield (9a) for protecting the food;
 - characterised in that the bird feeder (1) further comprises an electric motor (13) for rotating the guard (9).

2. A bird feeder (21) comprising:
 - a feeding unit (22) for holding bird food;
 - a guard (29) comprising a disc shaped shield (29a) for protecting the food;
 - characterised in that the bird feeder (21) further comprises an electric motor (33) for rotating the guard (29).

3. The bird feeder according to either of claims 1 or 2, wherein the guard (9, 29) is rotatable relative to the feeding unit (2, 22).

4. The bird feeder according to any previous claim, wherein the guard (9, 29) is rotatable at a speed suitable for making a squirrel slip or jump off the shield (9a, 29a).

5. The bird feeder according to any previous claim, further comprising a switch (12, 32) and a spring (14, 34) which are configured to activate the electric motor (13, 33) under a predetermined condition.

6. The bird feeder according to any previous claim, comprising a motor speed controller for adjusting the guard rotation speed.

7. The bird feeder according to any previous claim wherein the feeding unit (2, 22) comprises a food container (3).

8. The bird feeder according to any previous claim, further comprising a ring (10) suspending the bird feeder.
9. The bird feeder according to any one of claims 1 to 7 further having means for fixing the bird feeder to a pole.

Drawings of the Application

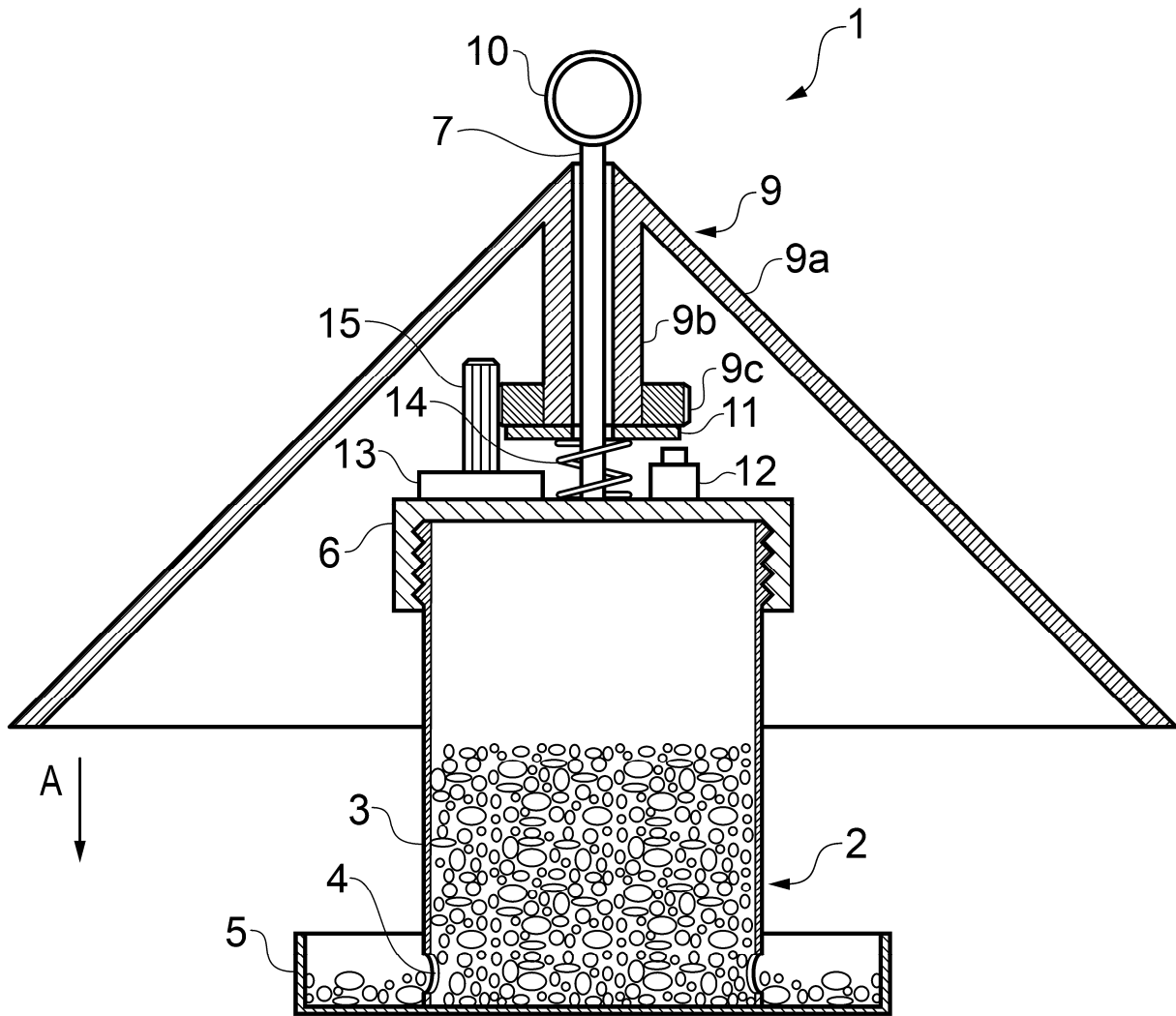

FIG. 1

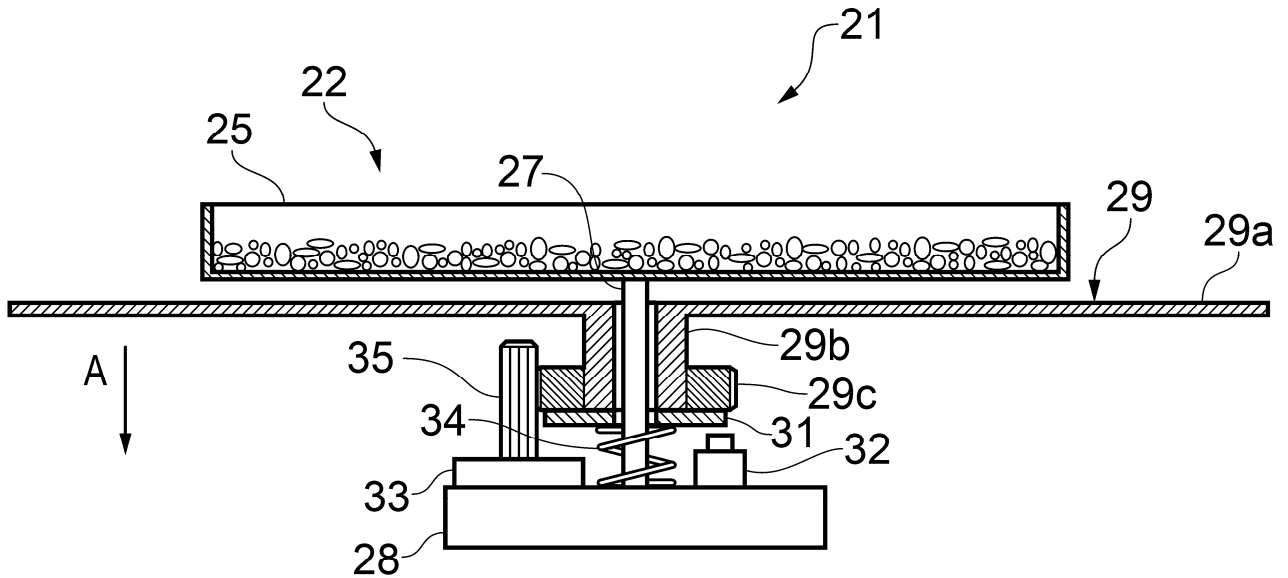

FIG. 2

Communication

1. D1, D2 and D3 are referred to in this communication. These documents were published before the priority date of the present application. D3 is cited in the present application.
2. Claim 1 is not allowable under Article 52(1) EPC, since its subject matter is not new in the sense of Article 54(1) and (2) EPC.
 - 2.1 D1 describes (see par. [002] and Fig. 1) a bird feeder (101) comprising:
 - a feeding unit (food tray 105) for holding bird food;
 - a guard (109) comprising a cone shaped shield (109a) for protecting the food; and
 - an electric motor (113) for rotating the guard (109).

Consequently, a bird feeder with all the features of claim 1 is already known from D1.

- 2.2 The subject matter of claim 1 is also not new with respect to D2:

D2 describes (see pars. [002], [003], [007] and Fig. 1) a bird feeder (201) comprising:

- a feeding unit (202) for holding bird food;
- a guard (209) comprising a cone shaped shield (209a) for protecting the food; and
- an electric motor (213) for rotating the guard (209).

Consequently, a bird feeder with all the features of claim 1 is already known from D2.

3. Claim 2 is not allowable under Article 52(1) EPC, since its subject matter is not new in the sense of Article 54(1) and (2) EPC.

D1 describes (see pars. [005] to [007] and Fig. 2) a bird feeder (121) comprising:

- a feeding unit (food tray 125) for holding bird food;
- a guard (129) comprising a disc shaped shield (129a) for protecting the food;
and
- an electric motor (133) for rotating the guard (129).

Consequently, a bird feeder with all the features of claim 2 is already known from D1.

4. The subject matter of claims 3 and 5 to 9 is also not new because the additional features of these claims are known from at least one of D1 and D2.

Regarding claim 3, D2 (see par. [007] and Fig. 1) discloses a bird feeder (201) wherein the guard (209) is rotatable relative to the feeding unit (202).

Regarding claim 5, both D1 (see pars. [003], [004] and Fig. 1; pars. [006], [007], [009] and Fig. 2) and D2 (see pars. [005], [006] and Fig. 1) disclose a bird feeder having a switch (112, 132; 212) and a spring (114, 134; 214) which are configured to activate the electric motor under a predetermined condition.

Regarding claim 6, D1 (see par. [010]) discloses a motor speed controller for adjusting the speed of rotation of the feeding unit and thus the guard rotation speed.

Regarding claim 7, D2 (see par. [003] and Fig. 1) discloses a feeding unit (202) comprising a food container (203).

Regarding claim 8, D1 (see par. [003] and Fig. 1) and D2 (see par. [003] and Fig. 2) both disclose a ring (110; 210) for suspending the bird feeder.

Regarding claim 9, D1 (see par. [008] and Fig. 2) discloses a bird feeder (121) having means for fixing the bird feeder to a pole.

5. For completeness it is noted that D3 (see pars. [007], [011] and Figs. 1 to 4) discloses bird feeders (301, 321) with guards (309, 329) comprising shields (309a, 329a) for protecting the food which are caused to rotate when an animal attempts to cross the shields.
6. Claim 4 is not clear in the sense of Article 84 EPC because it attempts to define the invention in terms of the result to be achieved. The speed of rotation of a guard having a shield which is sufficient for making a squirrel slip or jump off the shield depends on factors which are not defined in the claim, such as the weight of the squirrel.
7. The applicant is invited to file amended claims which take account of the above comments. The amended claims should be in conformity with Rule 43 (1) and (2) EPC.

Document D1

[001] Our company has developed two types of motorised bird feeders for use in a garden. The bird feeders comprise food trays which rotate slowly when a bird is feeding
5 so that the garden owner has good views of the bird.

[002] Fig. 1 shows a bird feeder 101 of the first type comprising an electric motor 113, a weight sensor 116 for activating the electric motor and a battery (not shown) for energising the electric motor. The electric motor 113 has a motor shaft 115 projecting
10 downwards to which a guard 109 and a food tray 105 are fixed. The guard 109 comprises a cone shaped shield 109a and a central hollow cylindrical portion 109b. The cone shaped shield 109a protects the food on the food tray 105 from rain and climbing animals.

15 [003] The weight sensor 116 comprises a housing 117, a plate 118, a rod 119, a spring 114, and a switch 112. The spring 114 is retained in the housing 117 and supports the plate 118 above the switch 112. The rod 119 is fixed at one end to the plate 118 and at its other end to the electric motor 113. A ring 110 is fixed to the housing 117 for suspending the bird feeder 101 by means of a string (not shown).

[004] Fig. 1 shows the bird feeder 101 when no bird is on the food tray 105. The plate 118 is pushed away from the switch 112 by the spring 114 and the electric motor 113 is off. When a bird is on the food tray 105, the additional weight of the bird pulls the plate 118 in the direction of the arrow A and the spring 114 is compressed.

5 When the weight on the food tray 105 exceeds a predetermined value, approximately corresponding to the weight of a small bird, the plate 118 presses on the switch 112, thereby activating the electric motor 113. Driven by the electric motor 113, the food tray 105 and the guard 109 accelerate slowly and rotate, allowing the bird to be viewed as desired. When the bird is no longer on the food tray 105, the spring 114 pushes the

10 plate 118 back to its position shown in Fig. 1 and the electric motor 113 is off.

[005] Fig. 2 shows a bird feeder 121 of the second type. The bird feeder 121 comprises a food tray 125 and a guard 129 fixed to the food tray 125. The guard 129 comprises a disc shaped shield 129a and a hollow cylindrical portion 129b extending downwards

15 from the centre of the shield. The shield 129a protects the food on the food tray 125 from climbing animals.

[006] The bird feeder 121 further comprises a hollow drive shaft 130a which is fixed to the lower surface of the food tray 125 and a gear wheel 130b which is fixed to the hollow

20 drive shaft. The hollow drive shaft 130a is rotatably mounted on a rod 127 which is fixed to a base plate 128. The hollow drive shaft 130a is supported on the base plate 128 by a washer 131 and a spring 134 which are also mounted on the rod 127.

[007] The bird feeder 121 further comprises an electric motor 133, a switch 132 for

25 activating the electric motor, and a battery (not shown) for energising the electric motor. The switch 132 and the electric motor 133 are mounted on the base plate 128. The electric motor 133 has a toothed motor shaft 135 which engages with the gear wheel 130b. The electric motor 133 can thus rotate the food tray 125 and the guard 129.

[008] A housing for protecting the electric motor 133 and the switch 132 is formed by a base plate 128, a cylindrical housing part 136 which is fixed to the base plate, the hollow cylindrical portion 129b of the guard 129 and the food tray 125. The base plate 128 is fixed to a pole 140, e.g. with screws.

5

[009] Fig. 2 shows the bird feeder 121 when no bird is on the food tray 125. The washer 131 is pushed away from the switch 132 by the spring 134 and the electric motor 133 is off. When a bird is on the food tray 125, due to the additional weight of the bird, the hollow drive shaft 130a slides on the rod 127 in the direction of the arrow A.

10 The hollow drive shaft 130a presses on the washer 131 and the spring 134 is compressed. When the weight on the food tray 125 exceeds a predetermined value, approximately corresponding to the weight of a small bird, the washer 131 presses on the switch 132, thereby activating the electric motor 133. Driven by the electric motor 133, the food tray 125 and the guard 129 accelerate slowly and rotate. When the
15 bird is no longer on the food tray 125, the spring 134 pushes the washer 131 and the food tray 125 back to their positions shown in Fig. 2 and the electric motor 133 is off.

[010] In the bird feeders of both the first and second types, a speed of rotation of up to 3 revolutions per minute for the food tray has been found to be suitable for viewing the
20 birds. Higher speeds of rotation may disturb the birds when feeding and may cause food to be thrown off the food tray. A motor speed controller may be provided for adjusting the motor speed and hence the speed of rotation of the food tray.

Drawings Document D1

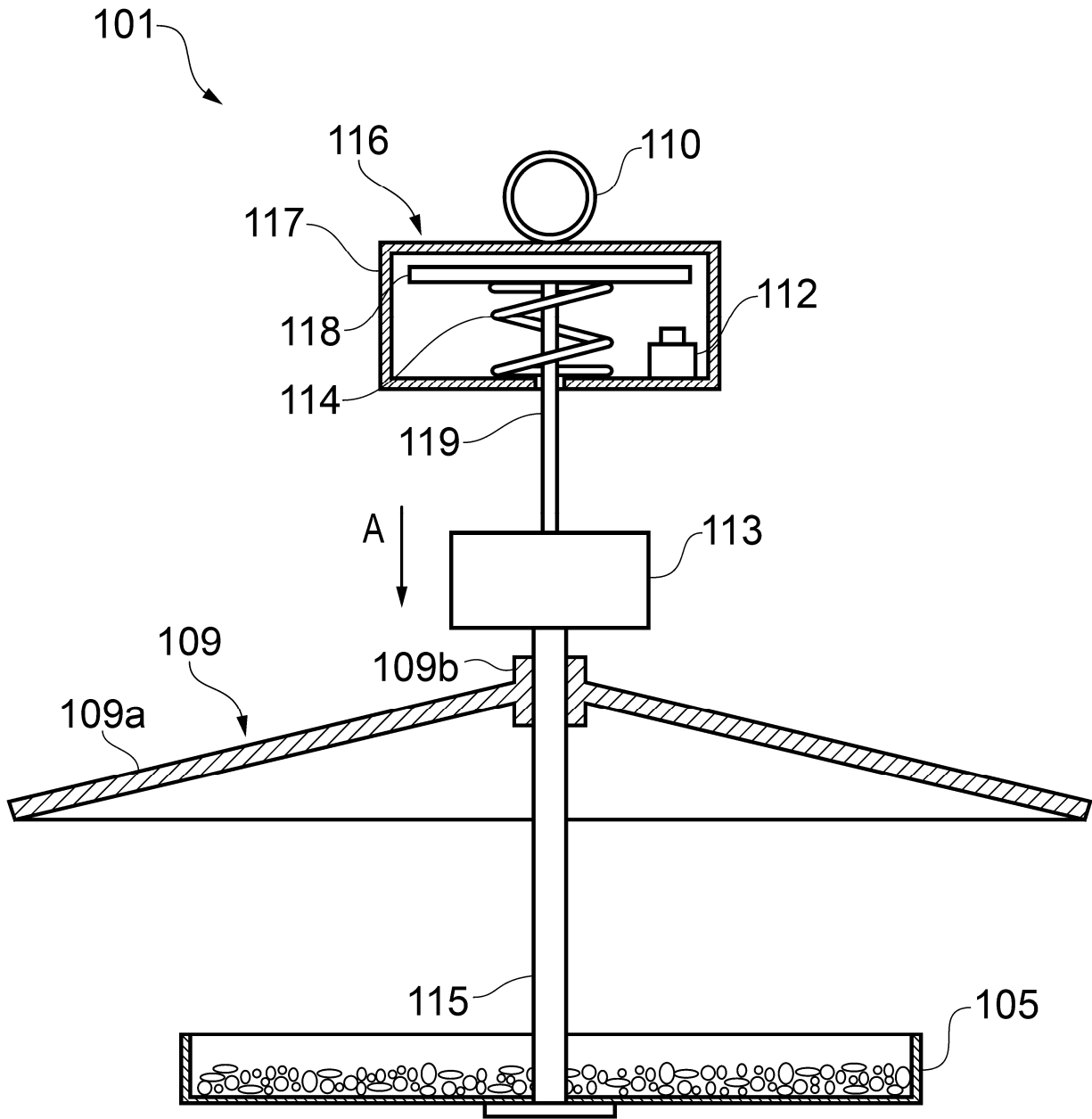

FIG. 1

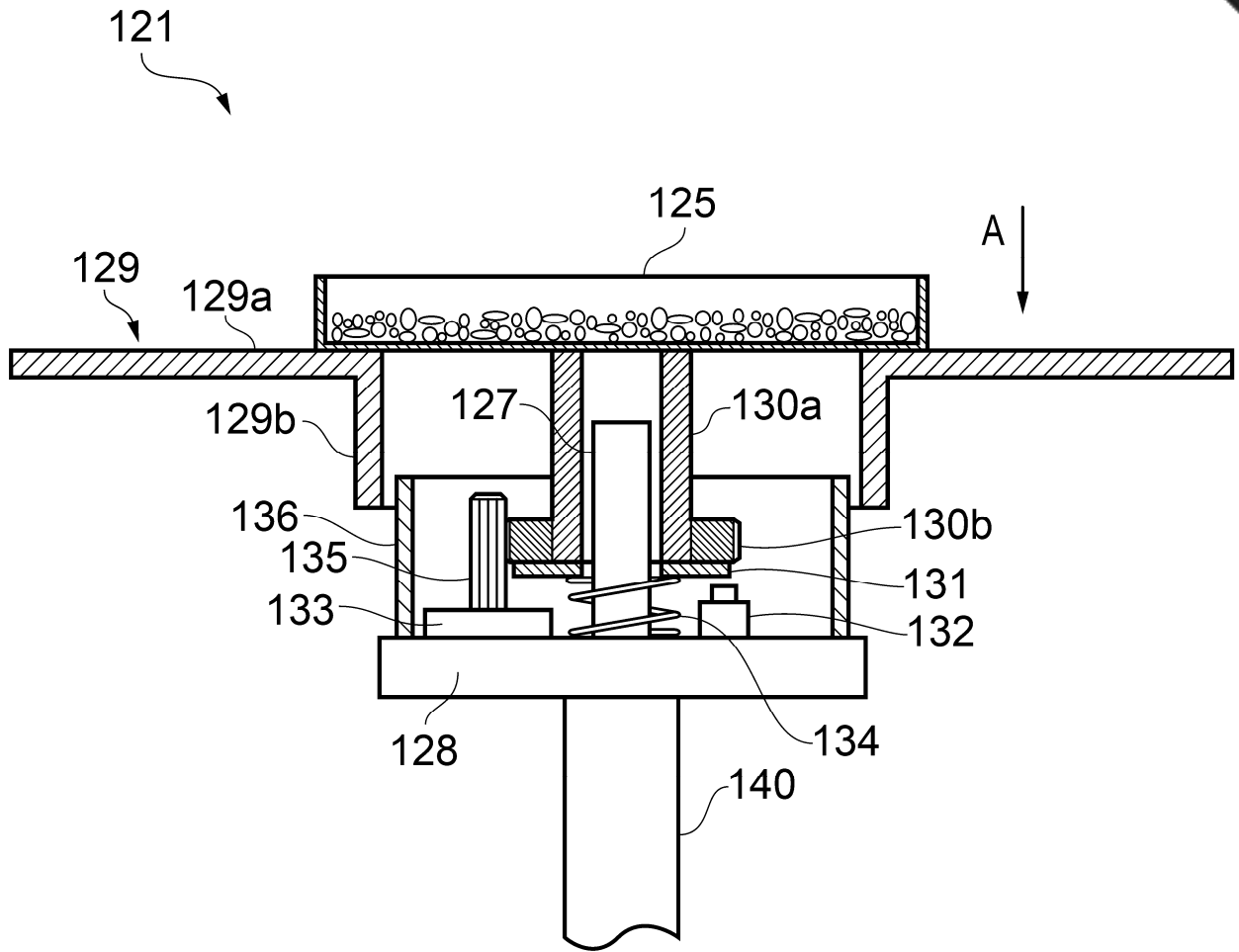

FIG. 2

Document D2

[001] Our bird feeder automatically dispenses food from a food container onto a food tray.

5

[002] Fig. 1 shows our bird feeder 201 whose basic components are a feeding unit 202 and a guard 209 for protecting the food from rain.

10 [003] The feeding unit 202 comprises a ring 210 for suspending the bird feeder 201, a food container 203 for storing bird food, an electric motor 213 for driving a conveyor screw 220, a motor controller (not shown), a battery (not shown) for energising the electric motor, a switching unit 216, and a food tray 205.

15 [004] The food container 203 comprises a screw lid 206 and has a hole 204 in its base through which food can be supplied to the food tray 205. The ring 210 is fixed to the upper surface of the screw lid 206. The electric motor 213 is fixed to the lower surface of the screw lid 206. The electric motor 213 has a motor shaft 215 to which the conveyor screw 220 is fixed.

20 [005] The switching unit 216 is fixed to the base of the food container 203. The switching unit 216 comprises a housing, a switch 212, a plate 218, a spring 214, and a rod 219. The rod 219 is fixed at one end to the plate 218 and at its other end to the food tray 205. The spring 214 is retained in the housing and supports the plate 218 and thus the food tray 205.

[006] Fig. 1 shows the bird feeder 201 when food is on the food tray 205. The weight of the food on the food tray 205 compresses the spring 214 and pulls the plate 218 away from the switch 212 so that the electric motor 213 is off. As the food gets eaten, the weight on the food tray 205 decreases. The spring 214 extends and pushes the plate 218 upwards in the direction of the arrow A. When the weight of the food remaining on the food tray 205 is less than a predetermined value, the plate 218 presses on the switch 212, thereby activating the electric motor 213. Driven by the electric motor 213, the conveyor screw 220 rotates and conveys food to the hole 204. The food then falls through the hole 204 onto the food tray 205. Due to the additional weight of the food on the food tray 205, the spring 214 is compressed, and the plate 218 is pulled back to the position shown in Fig. 1. When the plate 218 no longer presses on the switch 212, the motor controller causes the electric motor 213 to rotate through one further revolution before turning the electric motor off.

[007] The guard 209 comprises a cone shaped shield 209a and a hollow cylindrical portion 209b. The guard 209 is rotatably mounted on the feeding unit 202. The bird feeder 201 further comprises a first magnet 221 fixed to the hollow cylindrical portion 209b and a second magnet 221 fixed to the conveyor screw 220. The magnets 221 attract each other such that the guard 209 rotates together with the conveyor screw 220. If the food container 203 and the food tray 205 are empty, the plate 218 continuously presses on the switch 212 and the guard 209 rotates continuously. A mark (not shown) is provided on the shield 209a. Thus when the food container 203 is empty, the owner of the bird feeder 201 can see the rotating mark from a distance and knows that the food container should be refilled.

Drawing Document D2

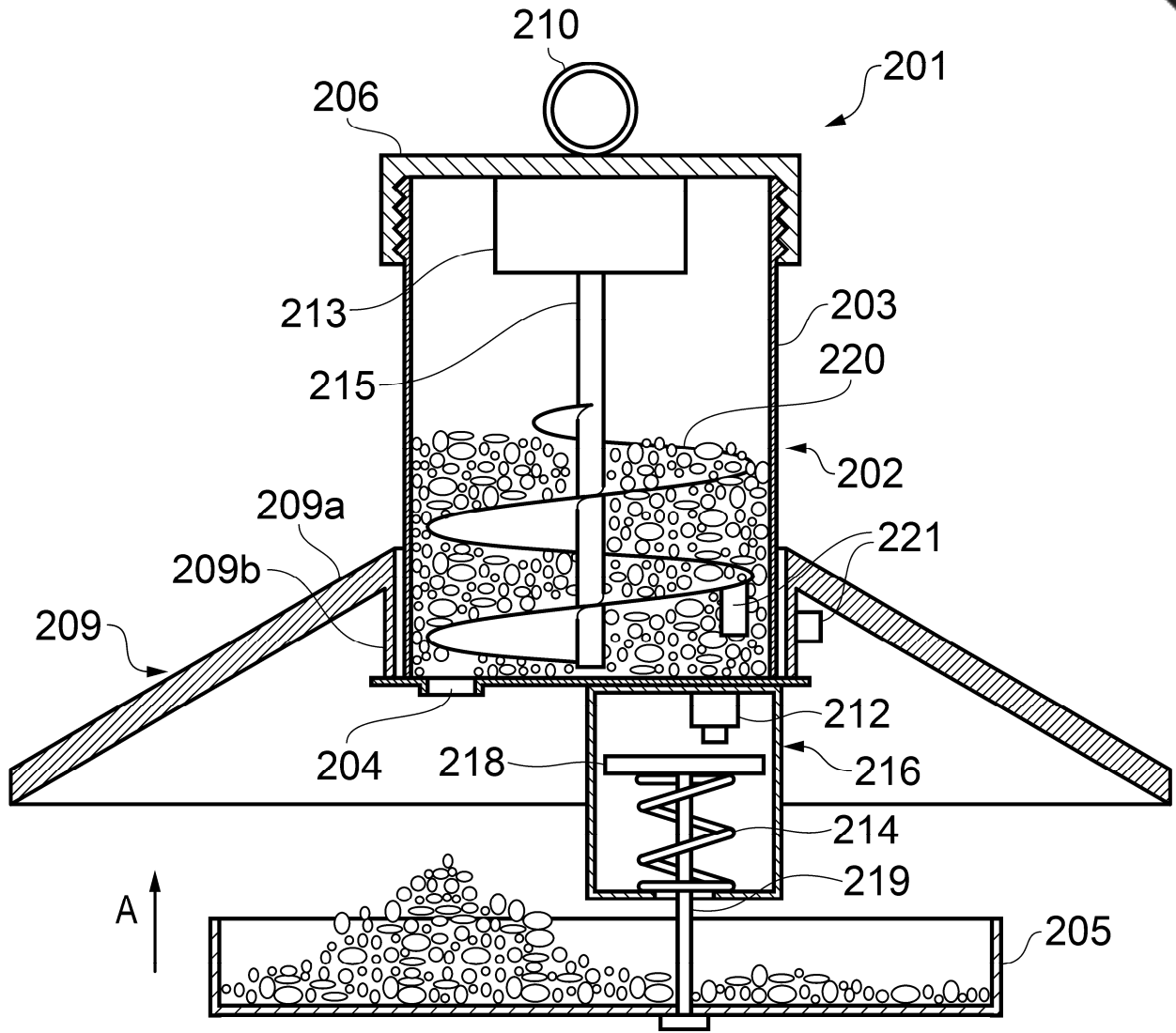

FIG. 1

Document D3

[001] The present invention relates to bird feeders. In order to prevent animals other than birds from gaining access to the food, bird feeders are normally raised above the ground. A bird feeder can be raised above the ground by suspending it by means of a string, or by mounting it on a pole. This may not be sufficient to prevent animals which can climb, e.g. squirrels, from gaining access to the food. In order to solve this problem, the bird feeders according to this invention comprise guards for protecting the food.

10 [002] Brief description of the drawings:

Fig. 1 is a perspective view of a first bird feeder.

Fig. 2 is a cross sectional view of the bird feeder shown in Fig. 1.

Fig. 3 is a perspective view of a second bird feeder.

Fig. 4 is a cross sectional view of the bird feeder shown in Fig. 3.

15

[003] The first bird feeder 301 shown in Fig. 1 comprises a feeding unit 302. The feeding unit 302 comprises a container 303 for storing bird food and a food tray 305. The container 303 comprises holes 304 through which food is supplied to the food tray 305.

20 [004] As shown in Fig. 2 the container 303 comprises a screw lid 306 which enables the container to be refilled.

[005] A rod 307 is fixed at one end to the upper surface of the screw lid 306 and at its other end to a ring 310. A string can be attached to the ring 310, e.g. with a knot.

[006] The bird feeder 301 further comprises a rotatable guard 309. The guard 309 has a cone shaped shield 309a for protecting the food and a hollow cylindrical portion 309b which extends downwards from the centre of the shield. The hollow cylindrical portion 309b is rotatably mounted on the rod 307. The guard 309 is supported on the screw lid 306 by a washer 311. The washer 311 reduces friction between the guard 309 and the screw lid 306.

[007] When a squirrel attempts to access the food on the food tray 305 from above, it must cross the shield 309a thereby causing the guard 309 to rotate. This sudden movement surprises the squirrel, so that it slips or jumps off the shield 309a. In this way the guard 309 prevents the squirrel from accessing the food.

[008] Fig. 3 shows a second bird feeder 321 which is mounted on a pole 340. The feeding unit 322 of the second bird feeder 321 corresponds to that of the first bird feeder 301 shown in Figs. 1 and 2. The feeding unit 322 comprises a container 323 and a food tray 325. The container 323 comprises a screw lid 326.

[009] As shown in Fig. 4, the bird feeder 321 further comprises a rod 327 and a base plate 328. The rod 327 is fixed at one end to the lower surface of the feeding unit 322 and at its other end to the base plate 328. The base plate 328 is fixed on the pole 340, e.g. with screws.

[010] The bird feeder 321 further comprises a rotatable guard 329. The guard 329 has a disc shaped shield 329a for protecting the food and a hollow cylindrical portion 329b which extends downwards from the centre of the shield. The hollow cylindrical portion 329b is rotatably mounted on the rod 327. The guard 329 is supported on the base plate 328 by a washer 331. The washer 331 reduces friction between the guard 329 and the base plate 328.

[011] When a squirrel attempts to access the food on the food tray 325 from below, it must cross the shield 329a thereby causing the guard 329 to rotate. This sudden movement surprises the squirrel, so that it slips or jumps off the shield 329a. In this way the guard 329 prevents the squirrel from accessing the food.

5

[012] Because the feeding units of the bird feeders described above do not rotate together with the guards, birds can continue to feed when the guards are rotating.

Drawings Document D3

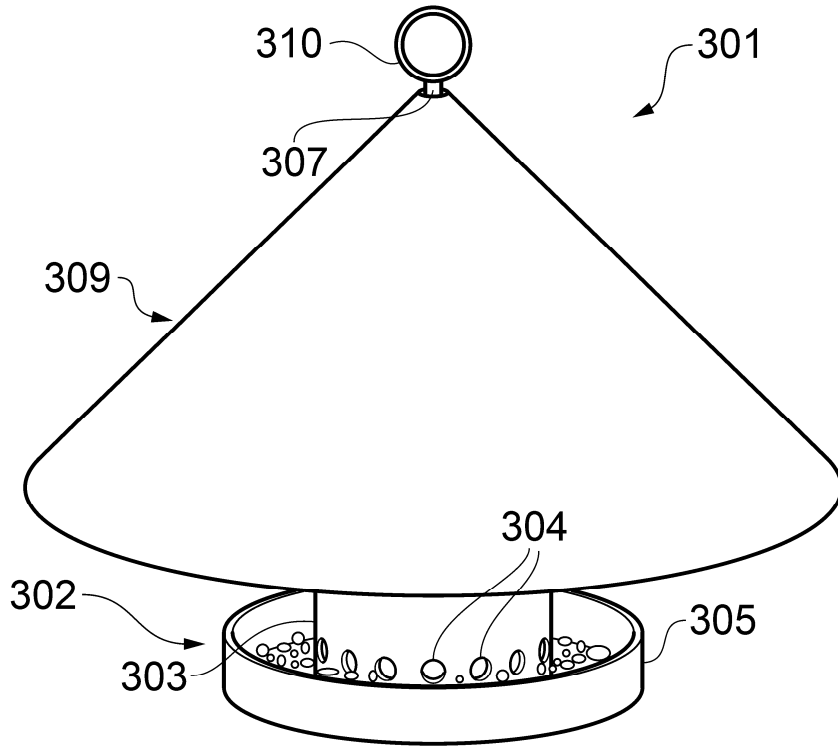

FIG. 1

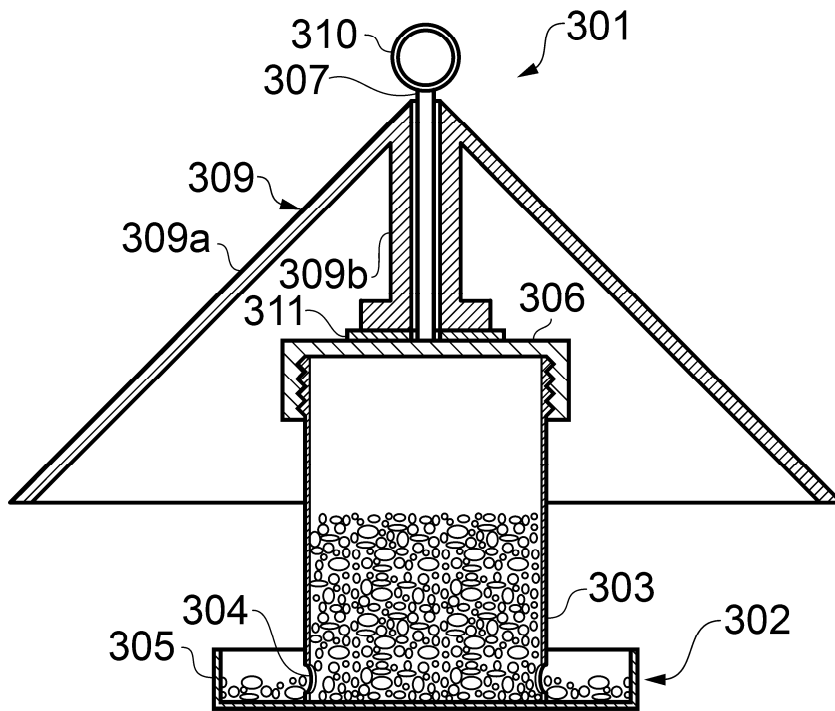
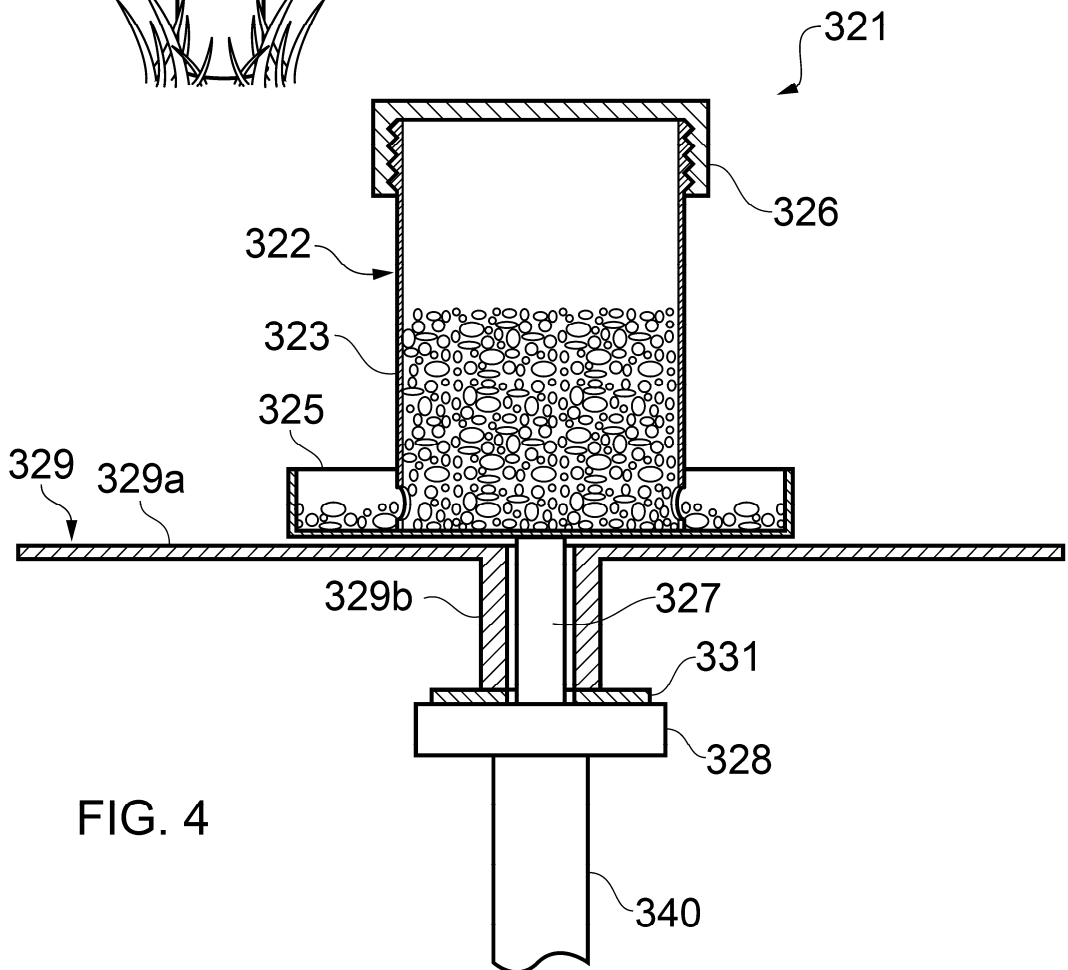
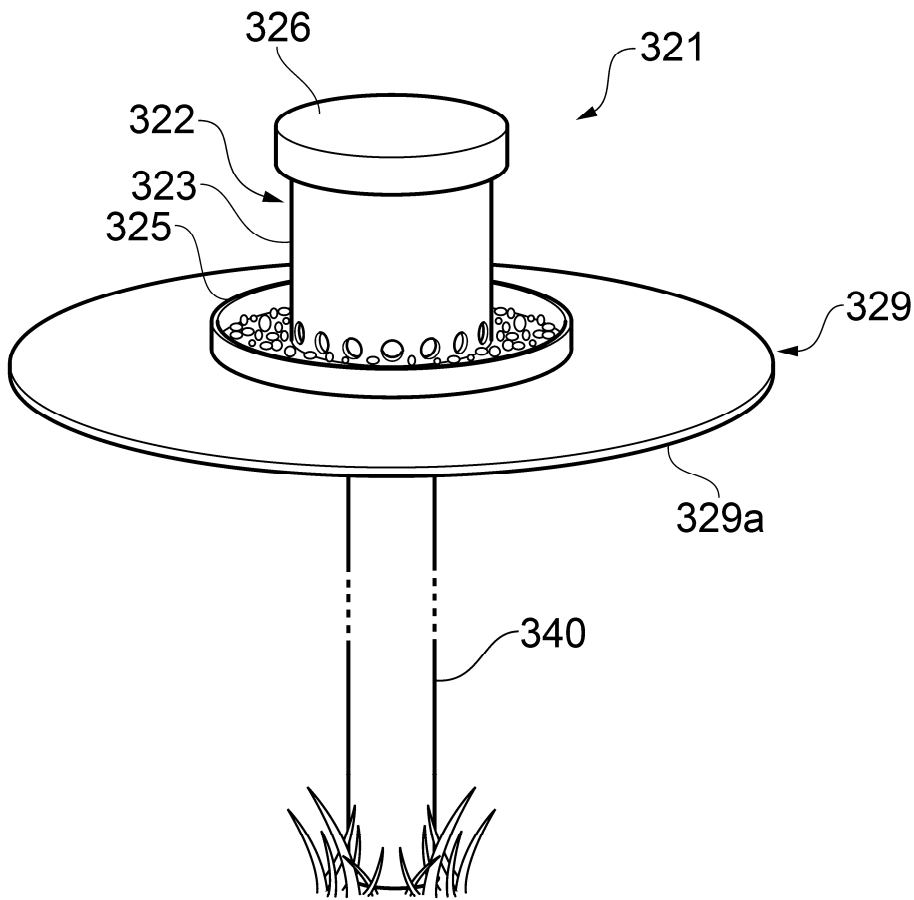

FIG. 2



Client's Letter

Dear Ms T. Witter,

In spite of the negative communication from the EPO, we believe you will be able to file a new set of claims fulfilling the conditions of the EPC.

Our bird feeders have been shown to be very effective in preventing squirrels from accessing bird food placed in them. We believe that the electric motor provides a reliable rotation, whilst at the same time minimal disturbance is caused to any birds which are feeding. None of the prior art bird feeders achieves this.

We are developing bird feeders having guards with differently shaped shields for protecting the food. We are also testing different types of weight sensors such as pressure sensor pads fixed on the shield. If possible, please ensure that an amended independent claim is not restricted with regard to these aspects.

We would ask you to file claims taking into account the above comments.

Yours sincerely,

A. Byrd

Working copy (for cutting and pasting)

Claims

1. A bird feeder (1) comprising:
 - a feeding unit (2) for holding bird food;
 - a guard (9) comprising a cone shaped shield (9a) for protecting the food;
 - characterised in that the bird feeder (1) further comprises an electric motor (13) for rotating the guard (9).

2. A bird feeder (21) comprising:
 - a feeding unit (22) for holding bird food;
 - a guard (29) comprising a disc shaped shield (29a) for protecting the food;
 - characterised in that the bird feeder (21) further comprises an electric motor (33) for rotating the guard (29).

3. The bird feeder according to either of claims 1 or 2, wherein the guard (9, 29) is rotatable relative to the feeding unit (2, 22).

4. The bird feeder according to any previous claim, wherein the guard (9, 29) is rotatable at a speed suitable for making a squirrel slip or jump off the shield (9a, 29a).

5. The bird feeder according to any previous claim, further comprising a switch (12, 32) and a spring (14, 34) which are configured to activate the electric motor (13, 33) under a predetermined condition.

6. The bird feeder according to any previous claim, comprising a motor speed controller for adjusting the guard rotation speed.

7. The bird feeder according to any previous claim wherein the feeding unit (2, 22) comprises a food container (3).
8. The bird feeder according to any previous claim, further comprising a ring (10) for suspending the bird feeder.
9. The bird feeder according to any one of claims 1 to 7 further having means for fixing the bird feeder to a pole.