

EUROPEAN QUALIFYING EXAMINATION 2009

PAPER B ELECTRICITY / MECHANICS

This paper comprises:

- | | |
|----------------------------------|--------------------|
| * Description of the Application | 2009/B(E/M)/e/1-4 |
| * Claims | 2009/B(E/M)/e/5 |
| * Drawings of the Application | 2009/B(E/M)/e/6-7 |
| * Communication | 2009/B(E/M)/e/8-10 |
| * Document D1 | 2009/B(E/M)/e/11 |
| * Drawings of Document D1 | 2009/B(E/M)/e/12 |
| * Document D2 | 2009/B(E/M)/e/13 |
| * Drawing of Document D2 | 2009/B(E/M)/e/14 |
| * Document D3 | 2009/B(E/M)/e/15 |
| * Drawings of Document D3 | 2009/B(E/M)/e/16 |
| * Client's Letter | 2009/B(E/M)/e/17 |

Description of the Application

[001] The invention relates to roof tiles comprising solar collectors.

5 [002] Fig. 1 shows part of a roof which comprises conventional roof tiles 1. The roof tiles 1 are supported on roof battens 2. Adjacent roof tiles 1 interlock with each other. Conventional roof tiles may have different forms.

[003] A known solar collector of a first type provides electrical energy. It comprises a
10 photovoltaic module which absorbs solar radiation and provides electrical energy. A known solar collector of a second type provides thermal energy. It comprises means for absorbing solar radiation to heat a fluid such as water or air.

[004] It is known to arrange solar collectors as solar panels. Typically solar panels are
15 mounted on the roofs of buildings. Such solar panels disturb the appearance of the buildings. Furthermore they may become detached from the roofs in strong winds.

[005] An object of the present invention is to address these drawbacks. This is achieved
by the subject matter of the claims.

20

[006] Brief description of the drawings:

Fig. 1 shows part of a roof.

Fig. 2 shows a roof tile according to the invention.

Fig. 3 shows a cross section of a roof tile according to a first preferred embodiment of
25 the invention.

Fig. 4 shows a cross section of a roof tile according to a second preferred embodiment of the invention.

Fig. 5 shows a cross section of a roof tile according to a third preferred embodiment of the invention.

30 Figs. 6a and 6b show two alternative arrangements of a part of the roof tiles of Figs. 4 and 5.

[007] The invention will now be described with reference to the drawings.

[008] Fig. 2 shows a roof tile 1 according to the invention. It comprises a transparent cover 3 for admitting solar radiation into the roof tile 1, a frame 4 and a solar collector 5 for absorbing the solar radiation. The frame 4 supports the transparent cover 3 and holds the solar collector 5. The transparent cover 3 protects the solar collector 5 from rain and dirt. The frame 4 can be made of ceramic and has the form of a conventional roof tile.

[009] Fig. 3 shows a roof tile 1 according to the first preferred embodiment of the invention. The roof tile 1 comprises a transparent cover 3, a frame 4 and a solar collector 5. The solar collector 5 comprises a photovoltaic module 6, a metal plate 7 and electrical wires 8. The photovoltaic module 6 is mounted on the metal plate 7. The photovoltaic module 6 can absorb solar radiation and provide electrical energy via the electrical wires 8.

[010] The efficiency of photovoltaic modules decreases as their temperature increases. The metal plate 7 ensures that heat is dissipated from the photovoltaic module 6. The metal plate 7 is preferably made of a metal with a high thermal conductivity such as copper.

[011] Fig. 4 shows a roof tile 1 according to the second preferred embodiment of the invention. This roof tile 1 has improved heat dissipation. The roof tile 1 comprises a transparent cover 3, a frame 4 and a solar collector 5. The solar collector 5 comprises a photovoltaic module 6, a metal plate 7, electrical wires 8, a fluid-tight passageway 9 for fluid, connectors 11 for fluid and a thermal insulation layer 10. The fluid-tight passageway 9 follows a meandering path along the metal plate 7.

[012] The photovoltaic module 6 is mounted on the metal plate 7. The photovoltaic module 6 and the metal plate 7 are arranged between the fluid-tight passageway 9 and the transparent cover 3 in such a way that heat can be transferred from the metal plate 7 to the fluid.

[013] Fluid can enter the fluid-tight passageway 9 via one of the connectors 11. It flows through the fluid-tight passageway 9 and exits the fluid-tight passageway via the other connector 11. The heated fluid can for example be used to heat a building. The fluid can for example be water or air.

5

[014] When mounting such roof tiles, the connectors of neighbouring roof tiles are interconnected via separate flexible hoses (not shown), to form a solar collector system in which fluid can flow successively through a plurality of roof tiles.

10 [015] Fig. 5 shows a roof tile 1 according to the third preferred embodiment of the invention. A solar collector system comprising a plurality of these roof tiles can be quickly assembled. The roof tile 1 shown in Fig. 5 differs from the one of Fig. 4 only in the arrangement of the connectors. In the roof tile 1 of Fig. 5, the connectors are arranged as a plug connector 11a and a socket connector 11b. The plug connector 11a
15 and socket connector 11b are so located on opposite sides of the roof tile, that when a plurality of such roof tiles are mounted as part of a roof, the plug connector of a roof tile engages with the socket connector of a neighbouring roof tile (not shown).

[016] Figs. 6a and 6b show two alternative arrangements of the fluid-tight passageways
20 of the roof tiles shown in Figs. 4 and 5. In Fig. 6a, the fluid-tight passageway 9 is formed by a metal tube 12 having a circular cross section. The metal tube 12 is fixed to the underside of the metal plate 7, e.g. by soldering. In Fig. 6b, the fluid-tight passageway 9 is formed by the metal plate 7 and a metal wall 13 having a U-shaped cross section. The metal wall 13 is fixed to the underside of the metal plate 7, e.g. by soldering.

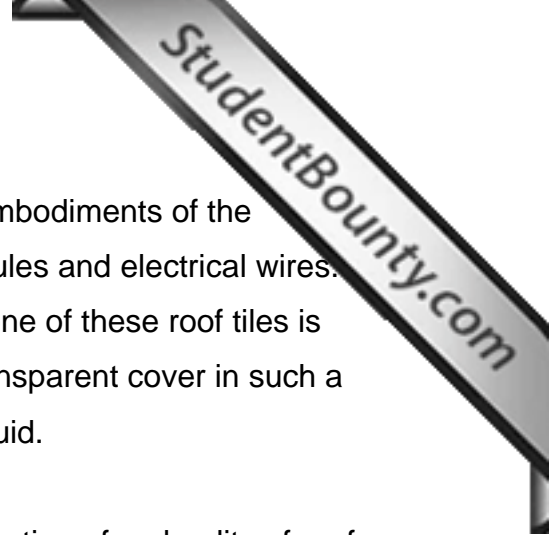

[017] Roof tiles according to the second and third preferred embodiments of the invention can alternatively be made without photovoltaic modules and electrical wires. As in the roof tiles shown in Figs. 4 and 5, the metal plate of one of these roof tiles is also arranged between the fluid-tight passageway and the transparent cover in such a way that heat can be transferred from the metal plate to the fluid.

5

[018] A solar collector system can be formed from any combination of a plurality of roof tiles according to the invention.

Claims

1. A roof tile (1) comprising a transparent cover (3) and a solar collector (5).
2. A roof tile (1) according to claim 1, comprising a frame (4) which supports the transparent cover (3) and which holds the solar collector (5).
3. A roof tile (1) according to claim 1 or 2, wherein the solar collector (5) comprises a metal plate (7).
4. A roof tile (1) according to claim 3, wherein the solar collector (5) comprises a photovoltaic module (6) mounted on the metal plate (7).
5. A roof tile (1) according to claim 3 or 4, wherein the solar collector (5) comprises a passageway (9) for fluid, and the metal plate (7) is arranged above the passageway (9) in such a way that heat can be transferred from the metal plate (7) to the fluid.
6. A roof tile (1) according to claim 5, wherein the passageway (9) is formed by a metal tube (12) having a circular cross section or by the metal plate (7) and a metal wall (13) having a U-shaped cross section.
7. A roof tile (1) according to claim 5 or 6, wherein the solar collector comprises a plug connector (11a) and a socket connector (11b) through which the fluid can enter and exit the passageway (9).
8. A solar collector system according to any of the above claims.

Drawings of the Application

1/2

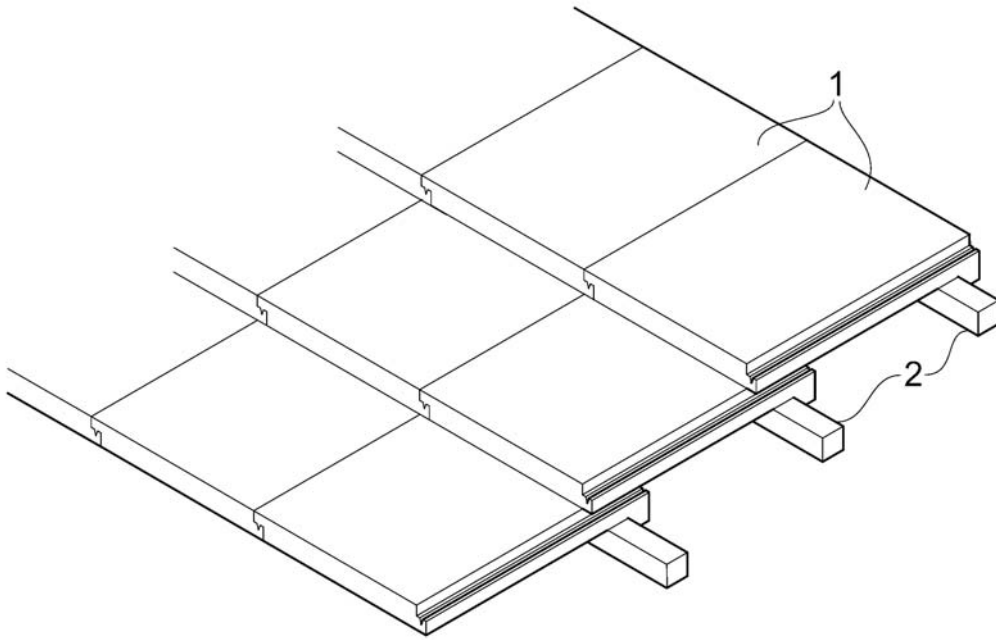

FIG. 1

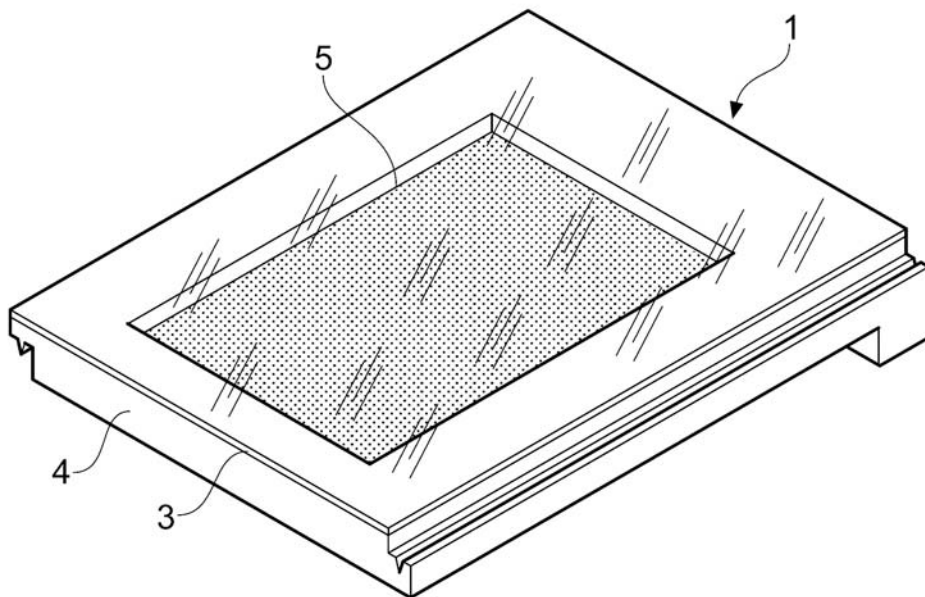

FIG. 2

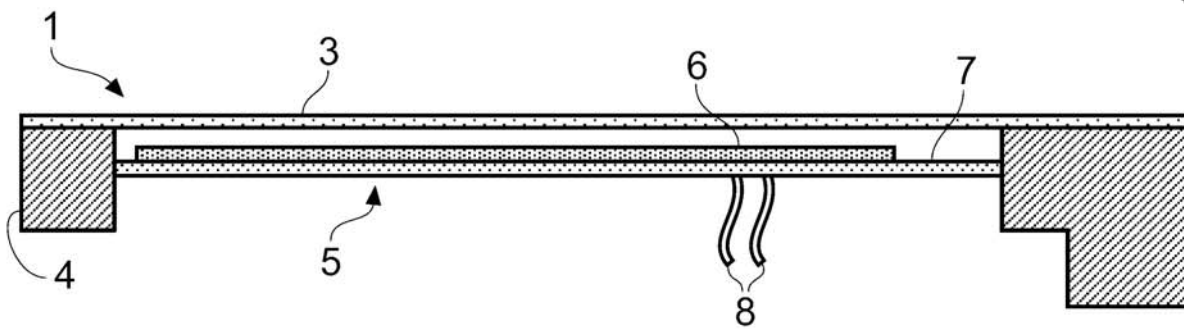

FIG. 3

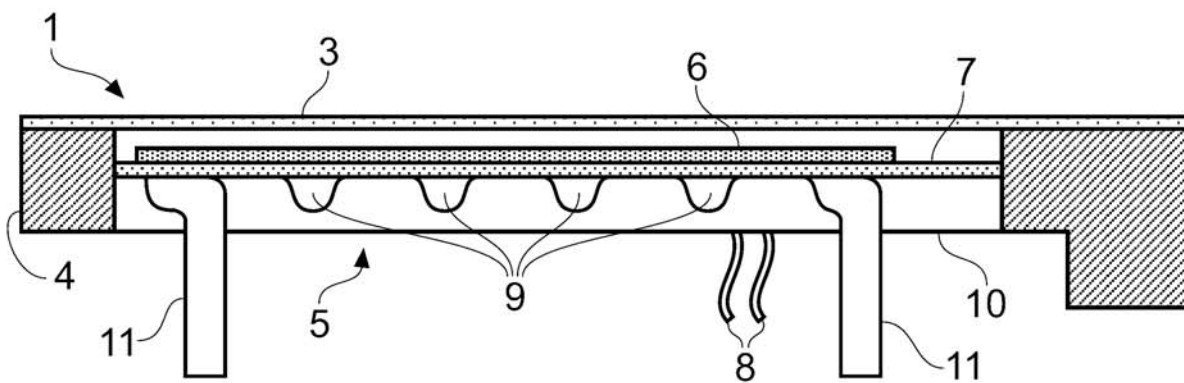

FIG. 4

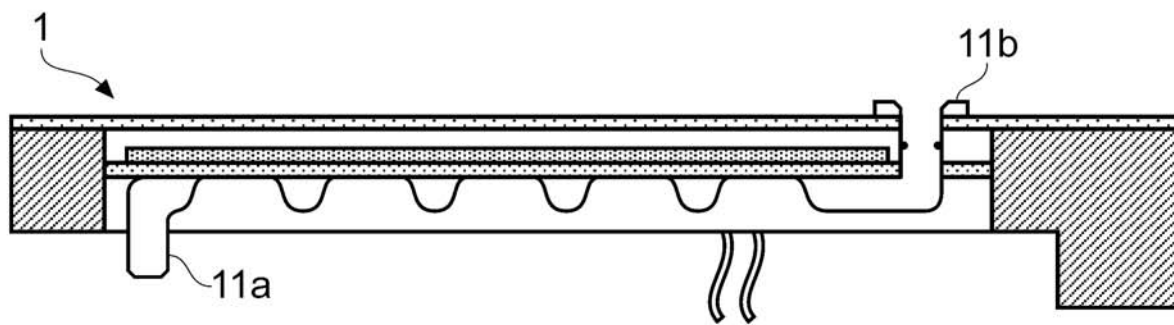

FIG. 5

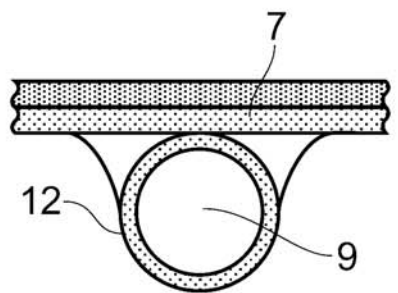

FIG. 6a

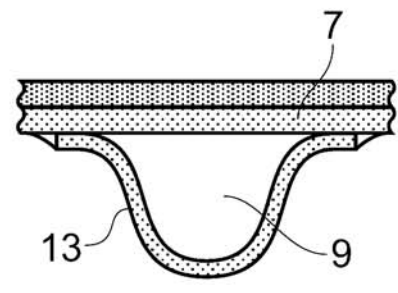

FIG. 6b

Communication

1. Documents D1, D2 and D3 were published before the priority date of the present application.
2. The present application does not meet the requirements of Art. 52(1) EPC because the subject matter of claims 1-7 is not new in the sense of Art. 54(1) and (2) EPC.
3. The subject matter of claim 1 is not new with respect to document D1 (see par. [001], [004] and Figs. 1 and 2). D1 discloses a roof tile (101) comprising a transparent cover (103) and a solar collector.
4. The subject matter of claim 1 is also not new with respect to document D2 (see par. [001] and Fig. 1). D2 discloses a roof tile (201) comprising a transparent cover (203) and a solar collector.
5. The subject matter of claim 2 is not new with respect to document D1 (see par. [001] and Fig. 1, frame (104)) and with respect to document D2 (see par. [001] and Fig. 1, frame (204)). The frames disclosed in both documents support transparent covers and hold solar collectors.
6. The subject matter of claim 3 is not new with respect to document D1 (see par. [002], [004] and Figs. 1 and 2, metal plate (107)) and with respect to document D2 (see par. [002] and Fig. 1, metal plate (207)).
7. The subject matter of claim 4 is not new with respect to document D1 (see par. [002] and Fig. 1). D1 discloses a photovoltaic module (106) mounted on the metal plate (107).

8. The subject matter of claim 5 is not new with respect to document D1 (see par. [004] and Fig. 2). D1 discloses a roof tile (101) having a solar collector comprising a passageway (109) for fluid, wherein the metal plate (107) is arranged above the passageway (109) in such a way that heat can be transferred from the metal plate (107) to the fluid.
9. The term "above" in claim 5 defines the position of the metal plate relative to the passageway ambiguously. Consequently the subject matter of claims 5, 6 and 7 can be considered as being not new with respect to the roof tile shown in Fig. 1 of document D2, if it were to be turned over.

The roof tile of document D2 has a solar collector which comprises a passageway for fluid (within the tube 212). When the roof tile is turned over, the metal plate (207) is arranged "above" the passageway in such a way that heat can be transferred from the metal plate (207) to the fluid (see par. [003] and Fig. 1) [claim 5].

Furthermore, document D2 discloses the following additional features:

- the passageway is formed by a metal tube (212) having a circular cross section (see par. [002] and Fig. 1) [claim 6];
 - the roof tile comprises a plug connector (211a) and a socket connector (211b) through which the fluid can enter and exit the passageway (within the tube 212) (see par. [002], [003] and Fig. 1) [claim 7].
10. Claim 8 is unclear (Art. 84 EPC), since it claims a system but refers to any of claims 1 to 7 which do not claim systems. Documents D1 (see par. [005]) and D2 (see par. [004]) both explicitly disclose solar collector systems.

11. It is noted that a solar collector which absorbs solar radiation to provide electrical and thermal energy is known from document D3.
12. The applicant is invited to file amendments taking the above objections and comments into account.

Document D1

[001] We have developed a new roof tile that comprises a solar collector for providing electrical energy. Fig. 1 shows our new roof tile 101 with part cut away. The roof tile 101
5 comprises a transparent cover 103, a solar collector and a ceramic frame 104. The frame 104 supports the transparent cover 103 and holds the solar collector.

[002] The solar collector comprises a metal plate 107, a photovoltaic module 106 which is mounted on the metal plate 107 and electrical wires 108 which are connected to the
10 photovoltaic module 106. The transparent cover 103 must be robust enough to protect the solar collector in all kinds of weather conditions.

[003] The efficiency of photovoltaic modules decreases as their temperature increases. The metal plate 107 dissipates heat from the photovoltaic module 106 and is preferably
15 made of copper.

[004] In very hot climates the heat dissipation by the metal plate 107 is however insufficient. Fig. 2 shows a view from underneath a modified roof tile 101 which is suitable for use in these climates. It differs from the roof tile of Fig. 1 only in that comb-
20 shaped metal fins 114 are attached to the underside of the metal plate 107. The fins 114 extend downwards from the metal plate 107 and have a large surface area for dissipating heat. Due to natural convection, air flows through passageways 109 between the fins 114. Heat is transferred from the fins 114 and the metal plate 107 to the air flowing in the passageways 109.

[005] When a plurality of our roof tiles are mounted as part of a roof, the electrical wires of neighbouring roof tiles are interconnected to form a solar collector system.

Drawings of Document D1

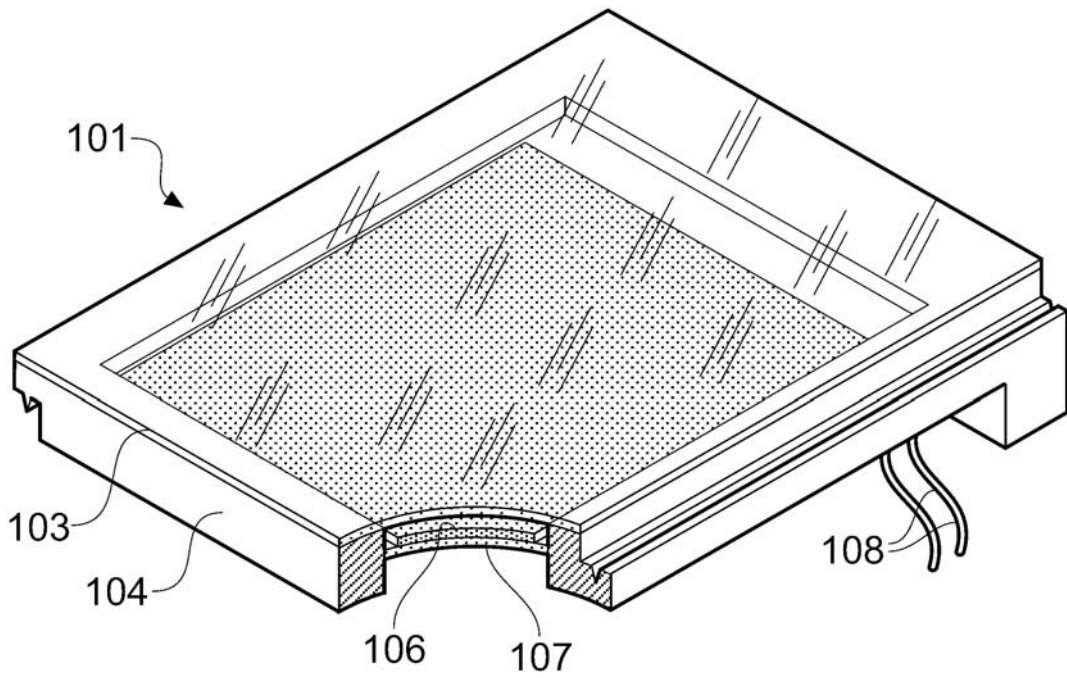

FIG. 1

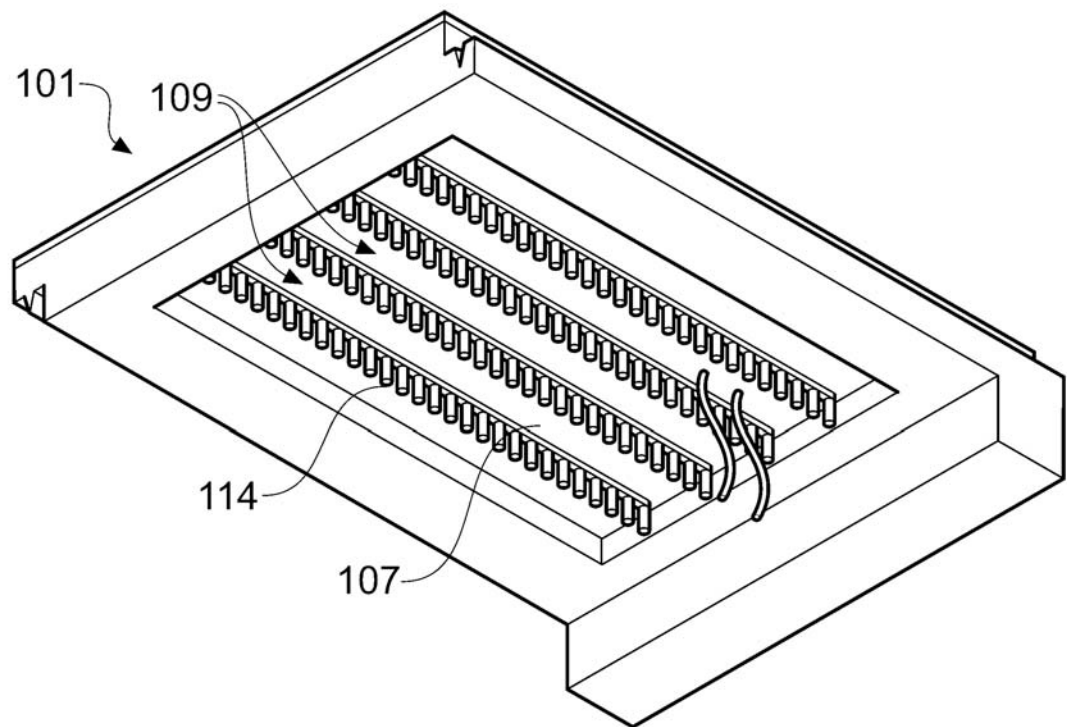

FIG. 2

Document D2

[001] We have developed a roof tile that comprises a solar collector for providing thermal energy. Fig. 1 shows our roof tile 201 with part cut away. The roof tile 201 comprises a transparent cover 203, a solar collector and a frame 204. The frame 204 supports the
5 transparent cover 203 and holds the solar collector.

[002] The solar collector comprises a thermal insulation layer 210, a reflecting metal plate 207 which is located on top of the thermal insulation layer 210, a metal tube 212
10 which is located above the metal plate 207, a plug connector 211a and a socket connector 211b. The socket connector 211b comprises a flexible hose portion. The metal tube 212 has a circular cross section and follows a meandering path.

[003] When the roof tile 201 is mounted as part of a roof (not shown), water can enter
15 and exit the metal tube 212 via the plug connector 211a and the socket connector 211b. Solar radiation passes through the transparent cover 203. A part of this solar radiation falls directly onto the metal tube 212 and heats the tube. Another part of this solar radiation falls onto the metal plate 207 and is reflected by it onto the tube 212, whereby heat is transferred from the metal plate 207 to the metal tube 212. Water flows through
20 the metal tube 212 and is thereby heated. The heated water can for example be used as domestic hot water.

[004] When mounting a plurality of these roof tiles as part of a roof, the plug connector of a roof tile is plugged into the socket connector of a neighbouring roof tile (not shown). In
25 this way a solar collector system is formed.

Drawing of Document D2

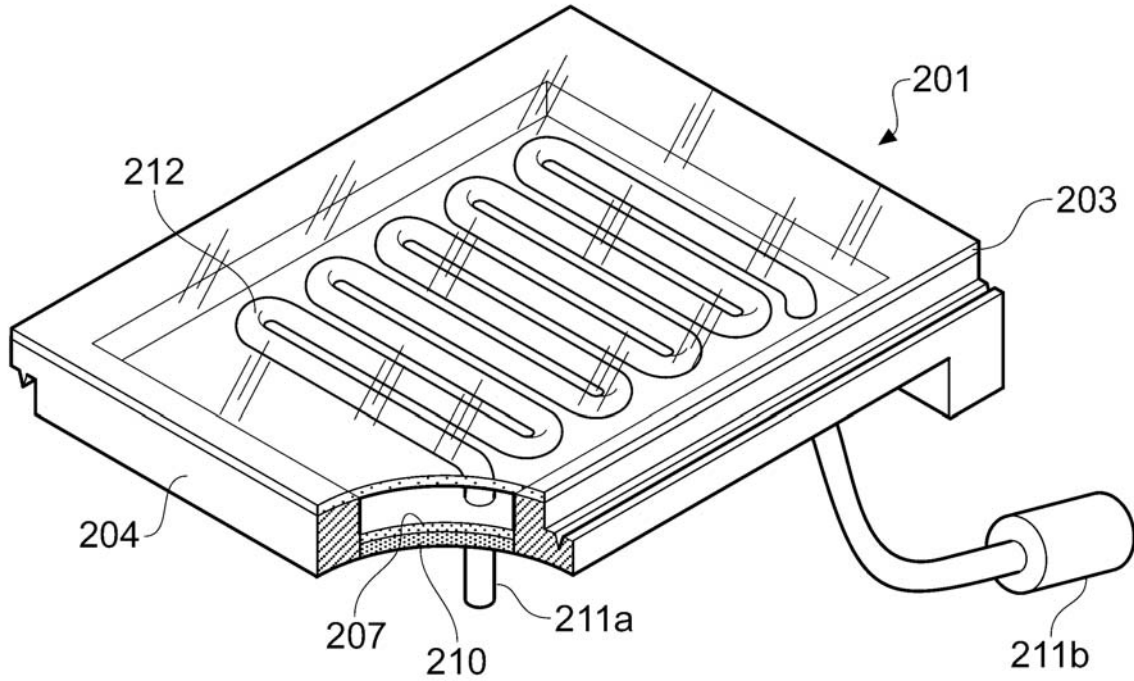

FIG. 1

Document D3

[001] Our invention relates to solar panels. A known solar panel provides electrical energy. It has glass lenses to focus solar radiation onto photovoltaic modules. A problem
5 with this panel is that the photovoltaic modules get hot and therefore their efficiency decreases. Our invention solves this problem.

[002] Fig. 1 shows a roof mounted solar panel 315 according to our invention. The panel provides electrical and thermal energy.
10

[003] Fig. 2 shows the panel 315 of Fig. 1 with part cut away. It comprises a metal plate 307 on which rows of photovoltaic modules 306 are mounted. A corrugated transparent cover 303 is so arranged on the plate 307 that fluid-tight passageways 309 are formed above the photovoltaic modules 306. Water is pumped through the
15 passageways 309. The water in the passageways 309 forms elongated lenses that focus solar radiation onto the photovoltaic modules 306. Heat is transferred from the photovoltaic modules 306 to the water. The heated water can for example be used to heat a swimming pool.

Drawings of Document D3

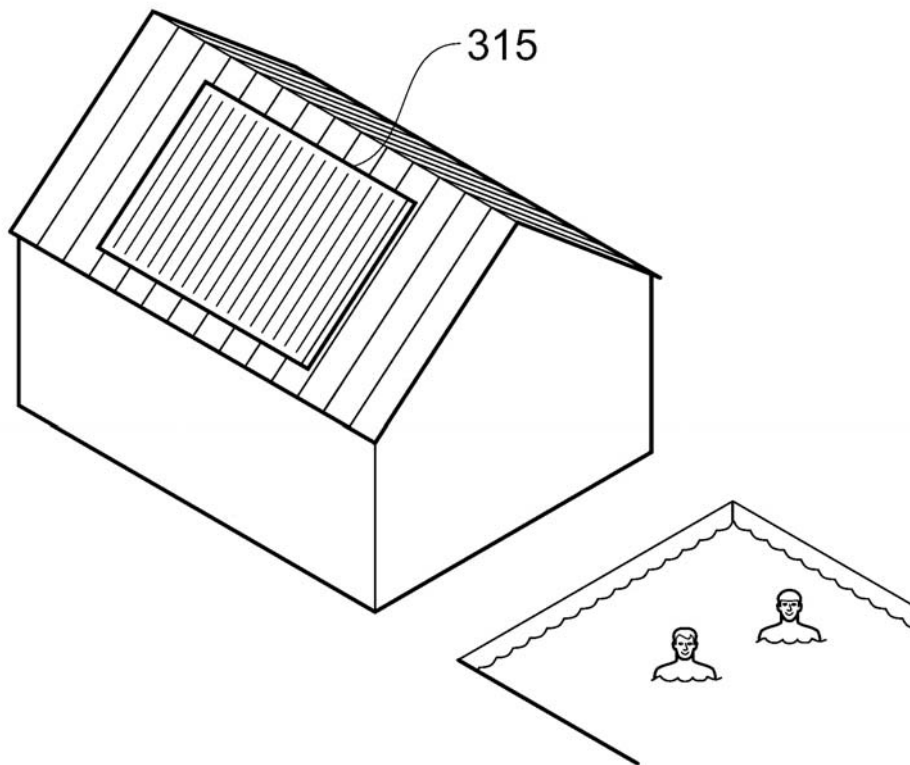

FIG. 1

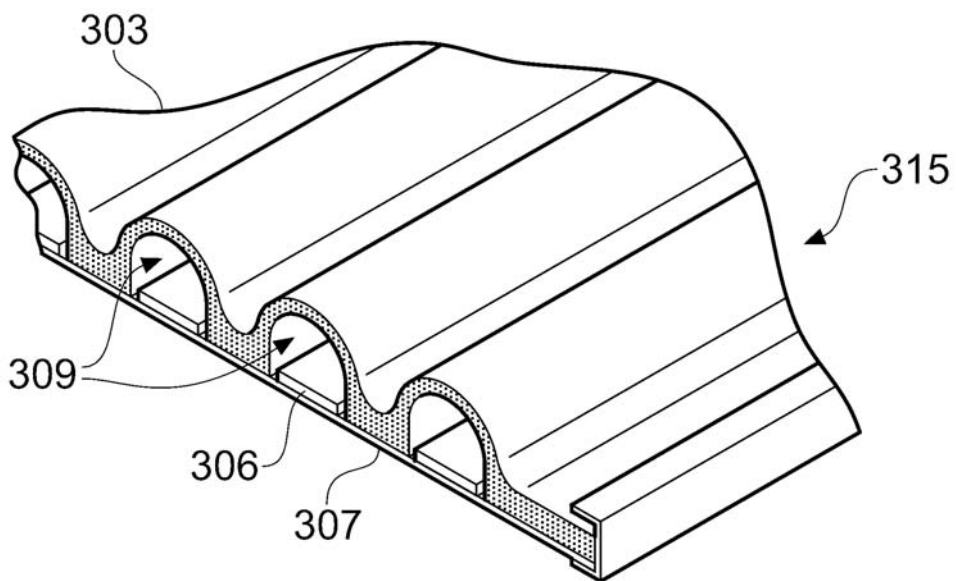

FIG. 2

Client's Letter

Dear Mr. Rufus,

Please file a new set of claims to protect as many of the preferred embodiments of our invention as possible.

The versions of our roof tiles which have no photovoltaic modules are very popular because they only cost a little more than conventional roof tiles.

All our roof tiles which comprise solar collectors which provide thermal energy have the advantage that no tubes can be seen in the roof tiles when they are mounted. Additionally these roof tiles are very robust. One customer reported that even when the transparent covers of some of our roof tiles were damaged in an exceptionally heavy hailstorm, no fluid leaked out of the roof tiles.

The roof tile shown in Fig. 5 of our application has the further advantage that, with such a roof tile, a solar collector system can be assembled faster than with the roof tile described in document D2. Please make sure that appropriate features of this roof tile are included in the claim set you are to file.

For your information we are currently developing a frameless roof tile comprising a transparent cover which is supported by a solar collector.

Regards

A. Tyler

Working copy (for cutting and pasting)

Claims

1. A roof tile (1) comprising a transparent cover (3) and a solar collector (5).
2. A roof tile (1) according to claim 1, comprising a frame (4) which supports the transparent cover (3) and which holds the solar collector (5).
3. A roof tile (1) according to claim 1 or 2, wherein the solar collector (5) comprises a metal plate (7).
4. A roof tile (1) according to claim 3, wherein the solar collector (5) comprises a photovoltaic module (6) mounted on the metal plate (7).
5. A roof tile (1) according to claim 3 or 4, wherein the solar collector (5) comprises a passageway (9) for fluid, and the metal plate (7) is arranged above the passageway (9) in such a way that heat can be transferred from the metal plate (7) to the fluid.
6. A roof tile (1) according to claim 5, wherein the passageway (9) is formed by a metal tube (12) having a circular cross section or by the metal plate (7) and a metal wall (13) having a U-shaped cross section.
7. A roof tile (1) according to claim 5 or 6, wherein the solar collector comprises a plug connector (11a) and a socket connector (11b) through which the fluid can enter and exit the passageway (9).
8. A solar collector system according to any of the above claims.