

## EUROPEAN QUALIFYING EXAMINATION 2006

### PAPER B ELECTRICITY / MECHANICS

This paper comprises:

- |                                  |                     |
|----------------------------------|---------------------|
| * Description of the Application | 2006/B(E/M)/e/1-3   |
| * Claims                         | 2006/B(E/M)/e/4     |
| * Drawings of the Application    | 2006/B(E/M)/e/5     |
| * Communication                  | 2006/B(E/M)/e/6-7   |
| * Document D1                    | 2006/B(E/M)/e/8     |
| * Drawings Document D1           | 2006/B(E/M)/e/9     |
| * Document D2                    | 2006/B(E/M)/e/10-11 |
| * Drawings Document D2           | 2006/B(E/M)/e/12    |
| * Document D3                    | 2006/B(E/M)/e/13    |
| * Drawings Document D3           | 2006/B(E/M)/e/14    |
| * Document D4                    | 2006/B(E/M)/e/15-16 |
| * Drawings Document D4           | 2006/B(E/M)/e/17    |
| * Client's Letter                | 2006/B(E/M)/e/18    |

## Description of the Application

### Seal

5 The present application relates to seals used to prevent the spread of smoke in the case of a fire. Such seals seal, for example, doors and windows.

A conventional rubber seal, arranged in a gap, does not sufficiently impede the flow of smoke through the gap. This is especially the case if the gap is between a part that can  
10 move, for example a door and a part that cannot move, for example a doorframe.

Document D1 describes such a conventional rubber seal arranged in the gap between a door and a doorframe. In order to overcome the above disadvantage, the doorframe of D1 additionally comprises a sealing element made of intumescent material. Intumescent  
15 material has a relatively high density at room temperature but transforms into foam when a certain threshold temperature is exceeded. In its foam state, intumescent material may have up to twelve times its original volume.

In the event of a fire, when the threshold temperature is exceeded, the intumescent  
20 sealing element is activated to form a foam which seals the gap between the doorframe and the door. Smoke is thereby prevented from passing through the gap.

A drawback of the intumescent sealing element according to D1 is that it is only  
25 activated after its temperature has been considerably increased by the fire. Before the sealing element is activated, dangerous gases and smoke may pass through the gap.

It is an object of the present invention to provide a seal that overcomes this drawback. A further object of the invention is to provide a fire protection system.

These objects are achieved by the subject-matter of the attached claims.

Brief description of the drawings:

5 Fig. 1 shows a portion of a seal according to the invention.

Fig. 2 shows a cross section of part of a closed door and part of a doorframe that is fitted with a seal according to the invention.

10 Fig. 3 shows the cross section according to Fig. 2 after activation of the seal.

Fig. 4 shows a fire protection system including a seal according to the invention.

Embodiments of the invention are described in detail as follows.

15

Fig. 1 shows a seal 1 comprising a sealing element 3 of intumescent material and a resistive heating wire 2 that is embedded in the intumescent material. In another embodiment (not shown in the drawings) the resistive heating wire is arranged adjacent to the intumescent material such that it is able to heat it.

20

Fig. 2 shows, in cross section, part of a doorframe 4 and part of a door 5. The doorframe 4 is fitted with a conventional rubber seal 6 and a seal 1 of the type shown in Fig. 1.

25 When an electric current flows in the resistive heating wire 2, it gets hot and transmits heat to the intumescent material of the sealing element 3. As soon as the threshold temperature of the intumescent material is reached, it transforms into foam. After the seal 1 has been activated in this way, the foam fills the gap between the door 5 and the doorframe 4 as shown in Fig. 3.

Alternatively the resistive heating wire of the above embodiments may be substituted with another electrical heating means that is suitable for activating the seal, e.g. a resistive foil or a resistive paint.

- 5 Fig. 4 schematically shows a fire protection system 7 that includes at least one fire detector 8 and at least one seal 1 fitted to a doorframe, as shown in Figs. 2 and 3. When the fire detector 8 detects a fire, it transmits a signal to a control unit 9. The control unit 9 then activates the seal 1 by passing an electric current through the resistive heating wire 2. The fire detector 8 may be located remotely from the seal 1. A door can therefore
- 10 be sealed before a fire has reached it. By employing a fire detector 8 with a high sensitivity, the seal 1 can be rapidly activated after a fire has broken out.

Some buildings are already provided with seals comprising intumescent material, for example as disclosed in the document D1. In order to save the costs of replacing such

15 existing seals, the invention also provides for improving an existing intumescent seal by adding a heating means of the type described above. The heating means must be arranged so that it can heat the intumescent material of the existing seal.

## Claims

1. A seal (1) comprising a sealing element (3) for sealing a gap, characterised in that the sealing element (3) can be activated by an activating means (2) to seal the gap.
2. The seal (1) according to claim 1 wherein the sealing element (3) comprises intumescent material.
3. The seal (1) according to claim 1 or 2 wherein the activating means is an electrical heating means (2).
4. In a fire protection system (7) having a control unit (9) and at least one fire detector (8), at least one seal (1) according to any previous claim that can be activated by said control unit (9) in response to a signal from said fire detector (8).

Drawings of the Application

1/1

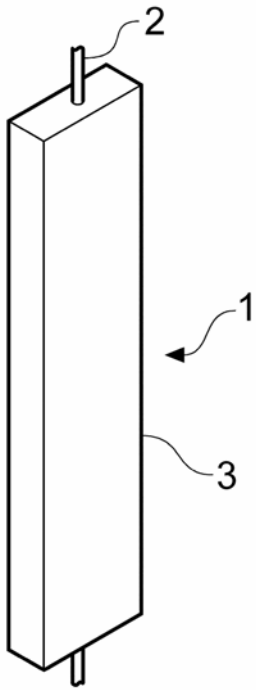

Fig. 1

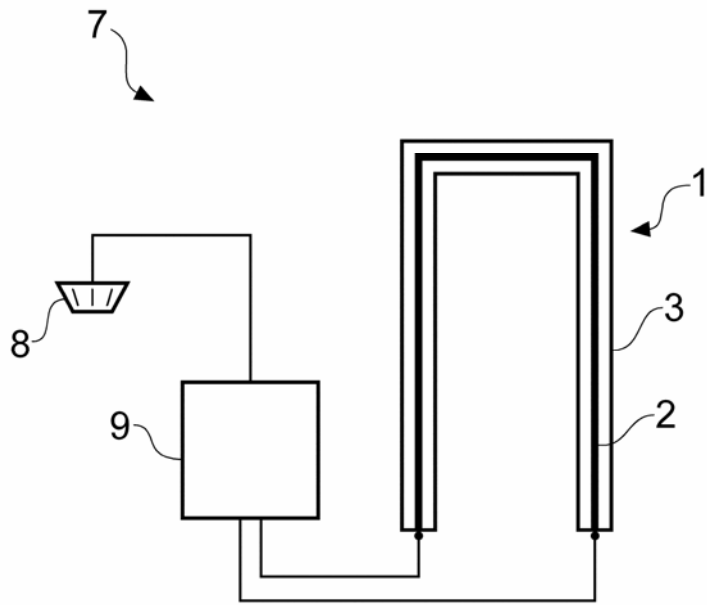

Fig. 4

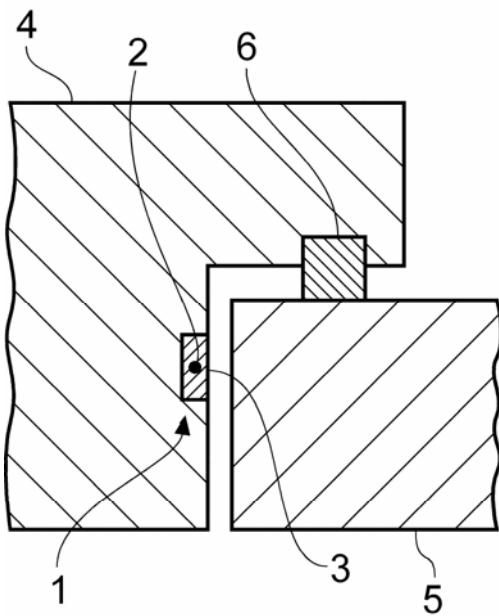

Fig. 2

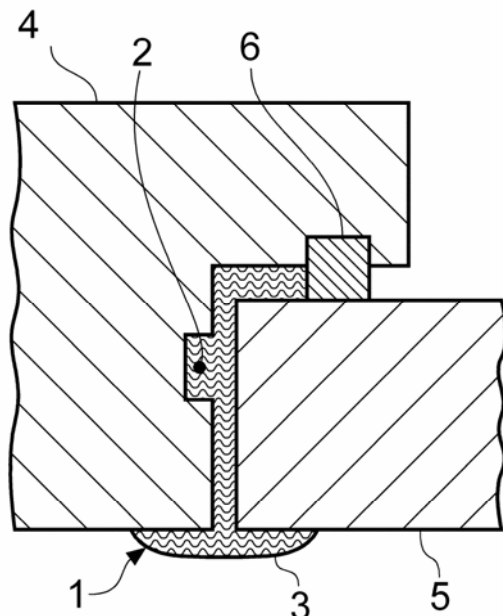

Fig. 3

### **Communication under Art. 96(2) EPC**

1. The examination is carried out on the basis of the application documents as originally filed.
2. The following documents are referred to in this communication: D1, D2, D3 and D4.

The present application does not claim any priority. Documents D1, D2 and D3 were published before the filing date of the present application and therefore belong to the state of the art according to Art. 54(2) EPC. Document D4 is a European patent application that was filed before but published after the filing date of the present application. The designation fees for D4 have been paid for all contracting states of the EPC. Document D4 therefore belongs to the state of the art according to Art. 54(3) EPC.

3. Claim 1 is not allowable because its subject-matter is not new with respect to any one of documents D1, D2 and D4, Art.52 (1) EPC.

D1 discloses (see Figs. 1 to 3) a seal comprising a sealing element (104) for sealing a gap, wherein the sealing element (104) can be activated by an activating means to seal the gap. The examiner notes that the seal according to D1 can in principle be activated by any suitable heat source, for example a fire.

D2 discloses (see Figs. 2 and 3) a seal comprising a sealing element (rubber tube door seal 203) for sealing a gap, wherein the sealing element (203) can be activated by an activating means (pump 204) to seal the gap.

D4 discloses (see Figs. 1 to 3) a seal (401) comprising a sealing element (402) for sealing a gap (408), wherein the sealing element (402) can be activated by an activating means (404) to seal the gap (408).

4. Claim 2 is not allowable since its subject matter is not new with respect to D1. D1 discloses (see second paragraph) a sealing element (104) comprising intumescent material.
5. Claim 3 is not allowable since its subject matter is not new with respect to D4. D4 discloses (see third paragraph) an electric heating means (404) that can activate the seal (401).

The subject-matter of claim 3 is also not new with respect to D1. Although D1 does not disclose an electrical heating means, the seal of D1 can be activated by a suitably placed electrical heating means (see point 3, second paragraph of this communication).

6. Claim 4 is not allowable under Art. 84 EPC because it is not clear. It is not possible to determine which of the features referred to in the claim are included within the scope of the claim (see Guidelines C III 4.8 b).

The examiner furthermore notes that D2 discloses (see Fig. 3) a fire protection system (205) in which a control unit (206) activates a seal (203) in response to a signal from a fire detector (207).

7. Finally, the examiner notes that it is known to activate intumescent material by means of an integrated heat source (see D3, third paragraph).
8. The applicant is invited to file amendments that take into account the above objections.



**Document D1**

This invention relates to a new kind of seal for a doorframe. The seal is made of an intumescent material.

5

Fig. 1 shows a doorframe 101 fitted with a door 102 and a conventional seal 103. The doorframe 101 is also fitted with an intumescent seal 104 according to the invention.

10

Fig. 2 shows a cross-sectional detail of the doorframe 101 and the door 102 of Fig. 1. The door 102 is closed. The seal 104 according to the invention is located in a groove 105 and has not been activated.

15

Fig. 3 shows the doorframe 101 and the door 102 after a fire has heated the intumescent material above its activation temperature. The intumescent material of the seal 104 has expanded to fill the space between the doorframe 101 and the door 102.

A further intumescent seal according to the invention (not shown in the drawings) may be provided on the floor, to seal the gap between the closed door and the floor, in the event of a fire.

**References:**

- 101 Doorframe
- 102 Door
- 103 Conventional seal
- 104 Seal according to the invention
- 105 Groove

Drawings of Document D1

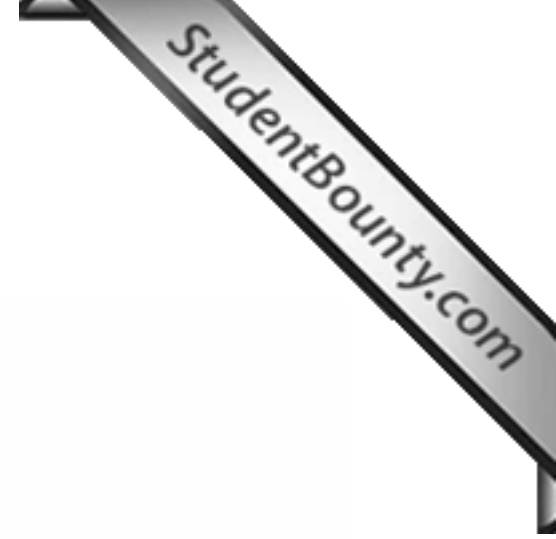

D1

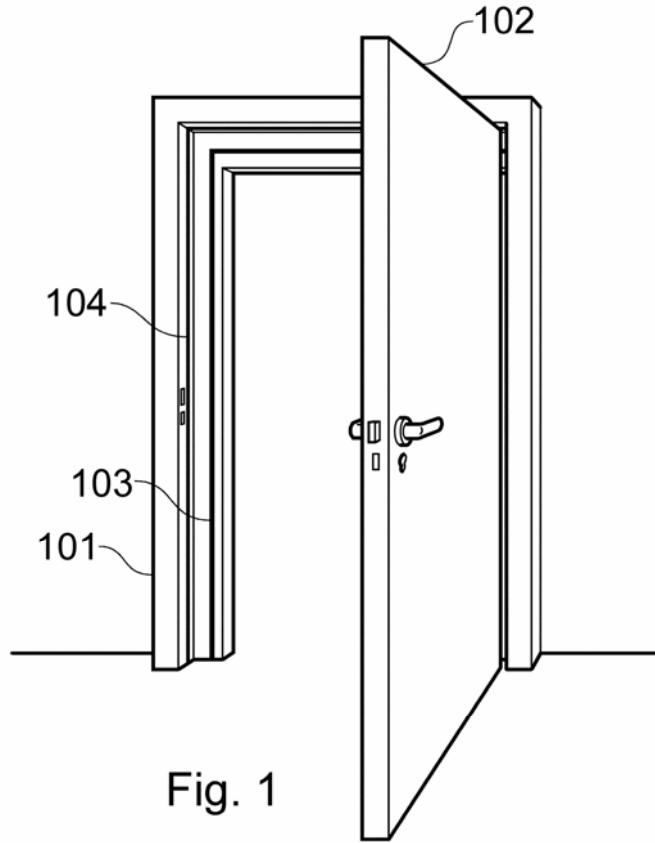

Fig. 1

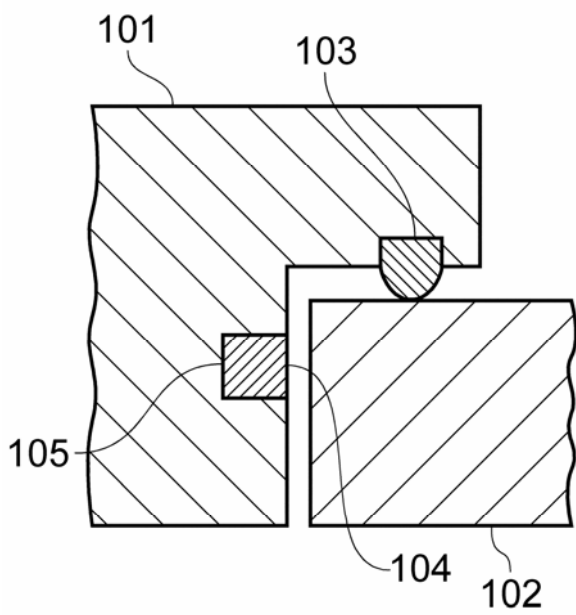

Fig. 2

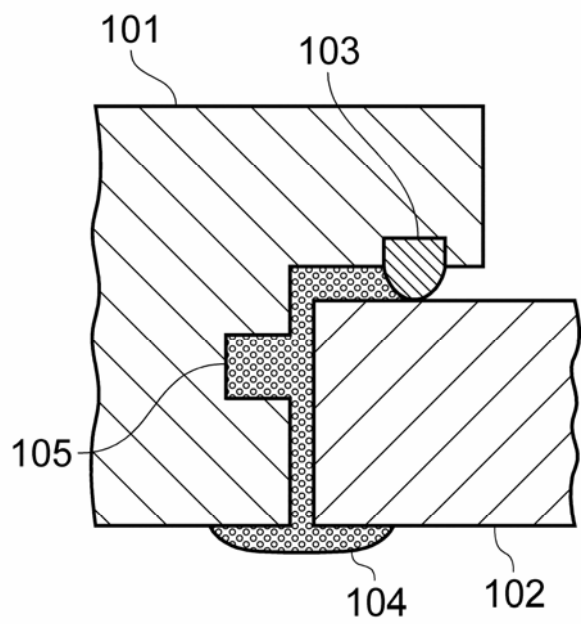

Fig. 3

**Document D2**

Our invention relates to door seals for use in vehicles and buildings. We have invented a rubber tube door seal that can be expanded by filling it with air.

5

Fig. 1 shows a doorframe 201 fitted with a door 202 and a rubber tube door seal 203. When the door 202 is closed, the seal 203 can be activated, as described below, to seal the gap between the doorframe 201 and the door 202. When the seal is deactivated the door 202 can be easily opened.

10

Fig. 2 shows schematically the arrangement of Fig. 1. The rubber tube door seal 203 is connected to a two-way electric air pump 204. When the pump 204 is operated to force air in the direction shown by the arrow A, the seal 203 inflates. In this way the seal 203 is activated. When the pump 204 is operated to suck air in the direction indicated by the arrow B, the seal 203 deflates. In this way the seal 203 is deactivated.

15

Fig. 3 shows a fire protection system 205 comprising the rubber tube door seal 203 of Figs. 1 and 2. A fire detector 207 is connected to a control device 206. When the fire detector 207 detects a fire, the control device 206 operates the pump 204 to activate the seal 203. The system enables doors to be sealed as soon as a fire has been detected.

20

References:

- 201 Doorframe
- 202 Door
- 203 Rubber tube door seal
- 204 Two-way electric air pump
- 205 Fire protection system
- 206 Control device
- 207 Fire detector

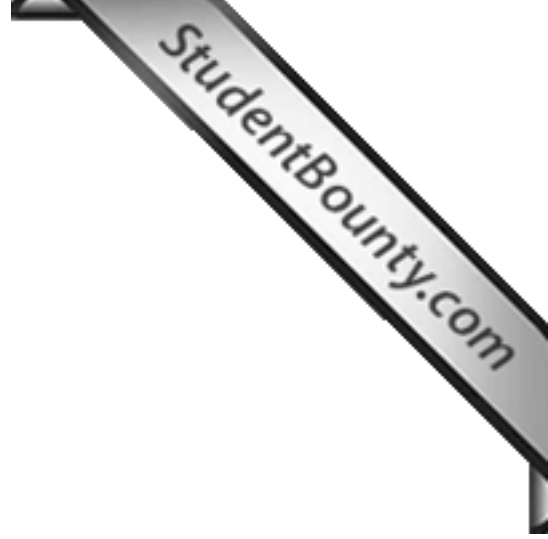

Drawings of Document D2

D2

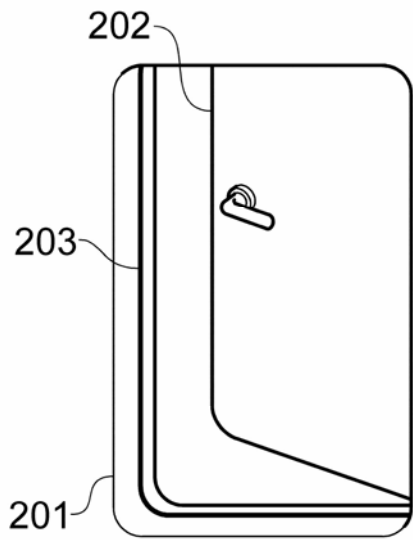
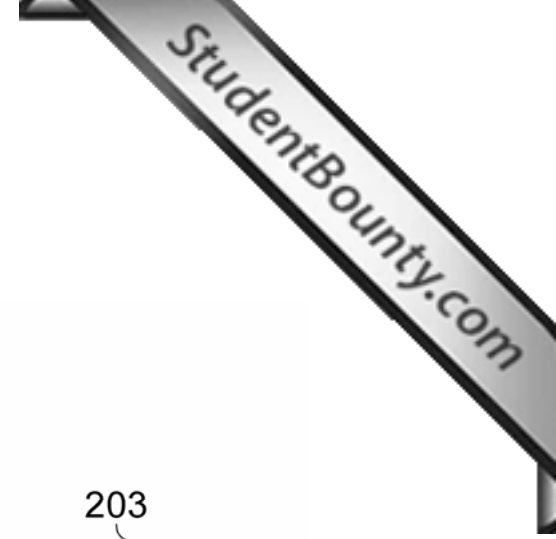

Fig. 1

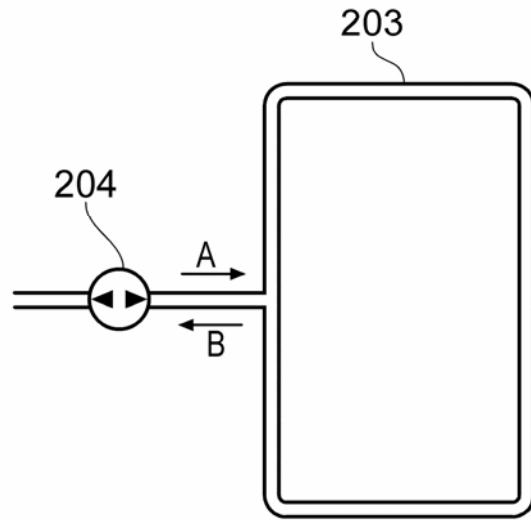

Fig. 2

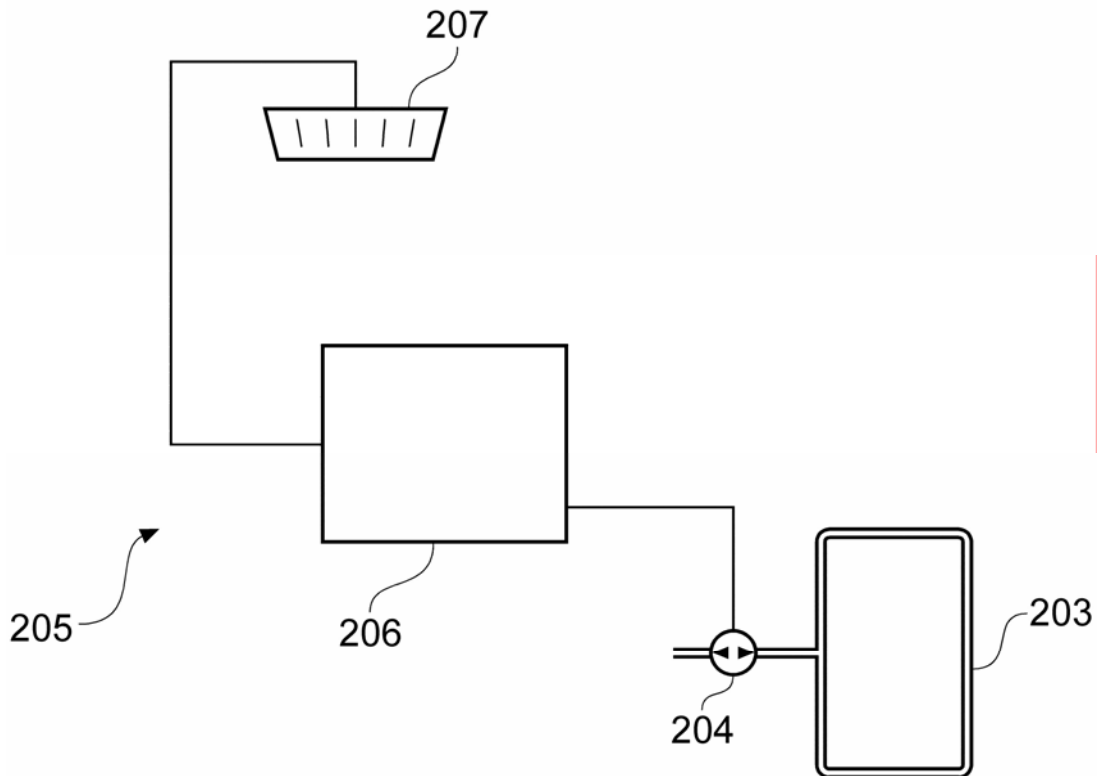

Fig. 3

**Document D3**

The Fast-Fix company now sells a new kind of frame for doors and windows that can be quickly installed by a single fitter.

5

In the past, frames had to be fixed in place by injecting an air-hardening foam. Now Fast-Fix supplies frames with multiple fixing points made of intumescent material. Intumescent material is well known as a sealing material and is activated by heat.

10 At each fixing point a capsule containing a chemical heating agent is integrated into the frame. Pulling a cord breaks the capsule to release the heating agent. The heating agent heats the intumescent material, causing it to transform into foam. The frame is fixed in place by the foam.

15 Fig. 1 shows a window frame 301 positioned in a wall 302 prior to breaking capsules 303. Intumescent material 304 is positioned at each corner of the frame 301 and is activated by pulling respective cords 305.

20 Fig. 2 shows the window frame 301 after activation of the material 304 which has expanded and fixed the frame 301 in the wall 302.

# D3

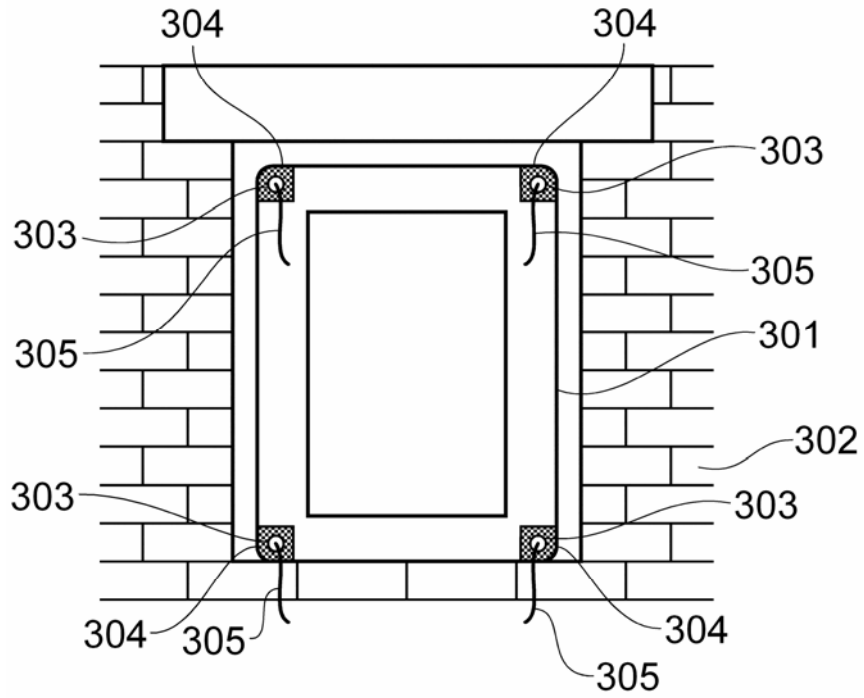

Fig. 1

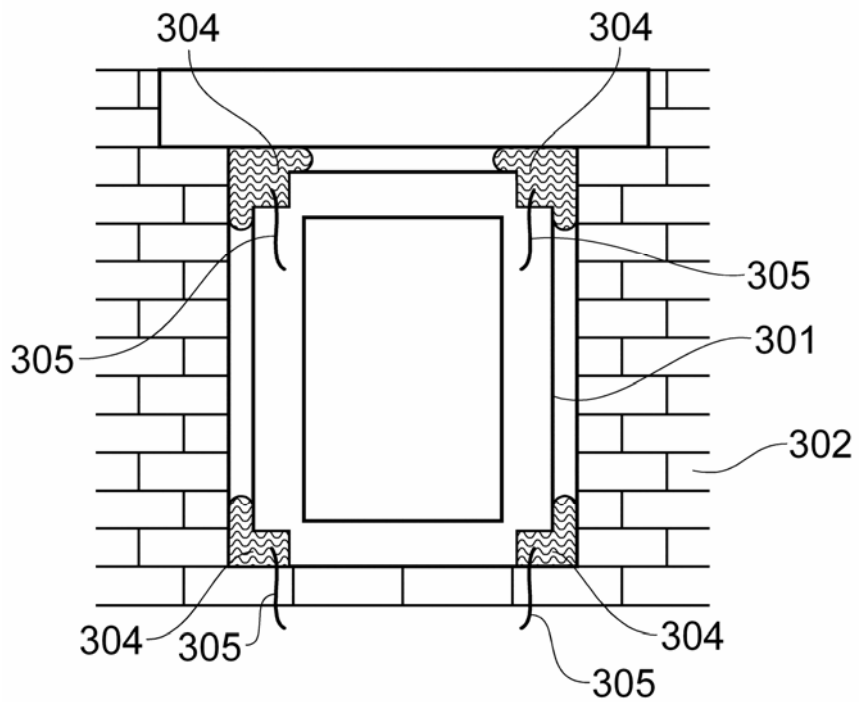

Fig. 2

**Document D4 (cited according to Art. 54(3) EPC)**

The invention relates to a fire seal for use in a door. The fire seal comprises an elastic strip. The strip is folded in a pre-stressed state and kept in this state by means of an adhesive layer. The adhesive layer is solid at room temperature. Melting the adhesive layer allows the strip to unfold, thereby activating the fire seal.

Fig. 1 shows a fire seal according to the invention before its activation.

Fig. 2 shows an arrangement of a door, a doorframe and seals, including the fire seal of Fig. 1.

Fig. 3 shows the arrangement of Fig. 2 after activation of the fire seal.

Fig. 1 shows an elastic strip 402 that is glued in a folded position by an adhesive layer 403. A resistive heating wire 404 is located in the adhesive layer 403. To activate the fire seal 401 an electric current is supplied to the resistive heating wire 404 which heats up. The adhesive layer 403 then melts and the elastic strip 402 unfolds.

Fig. 2 shows part of a doorframe 405 and part of a closed door 406. The doorframe 405 is fitted with a conventional seal 407 and a fire seal 401 according to the invention. The seals 401 and 407 are located in respective grooves in the doorframe 405. Between the fire seal 401 and an adjacent part of the door 406 there is a gap 408. Prior to activation of the fire seal 401, the gap 408 is open.

Fig. 3 shows the arrangement of Fig. 2 after the fire seal 401 has been activated, as described above, to seal the gap 408.

For clarity, the resistive heating wire is not shown in Figs. 2 and 3.



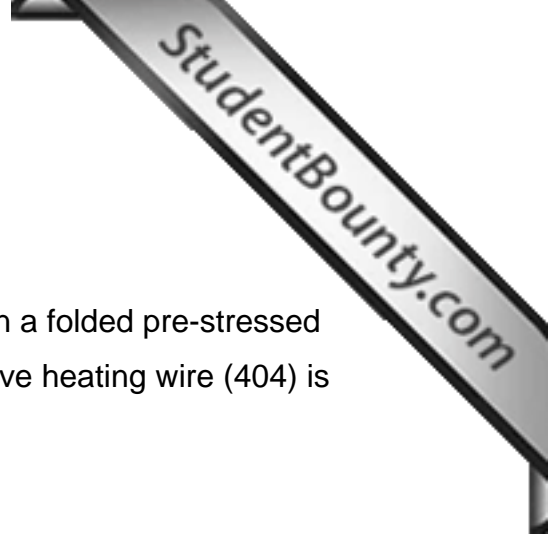

Claim

A fire seal (401) comprising an elastic strip (402) that is held in a folded pre-stressed state by an adhesive layer (403) characterised in that a resistive heating wire (404) is  
5 located in the adhesive layer (403).

Drawings of Document D4

D4

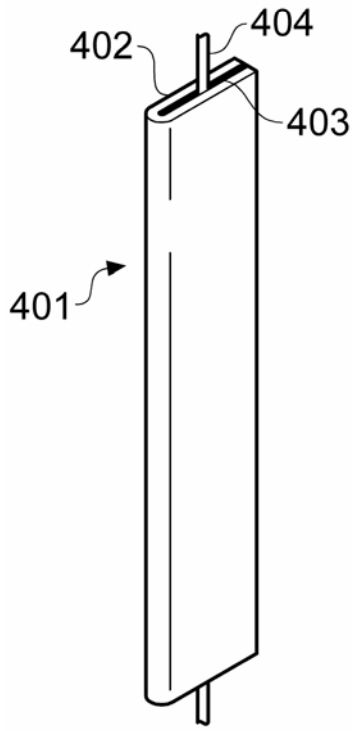
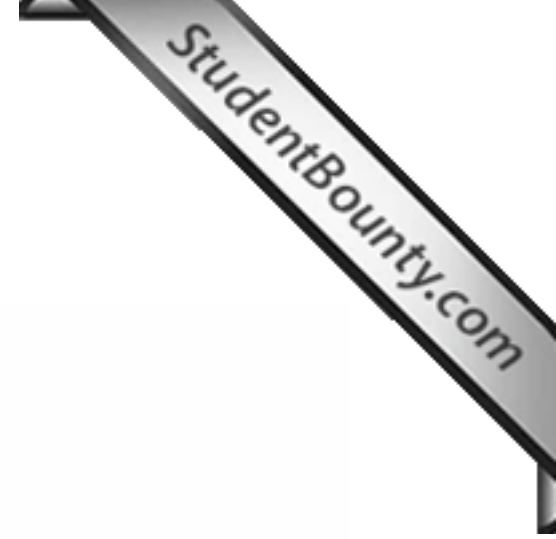

Fig. 1

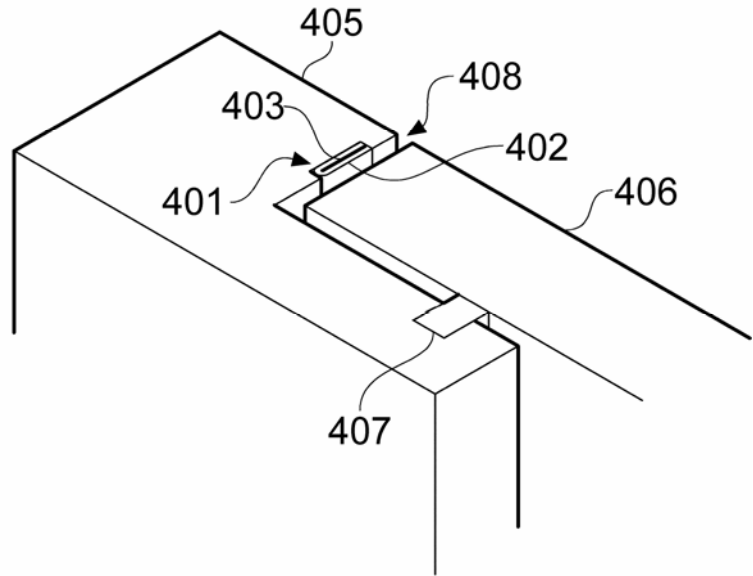

Fig. 2

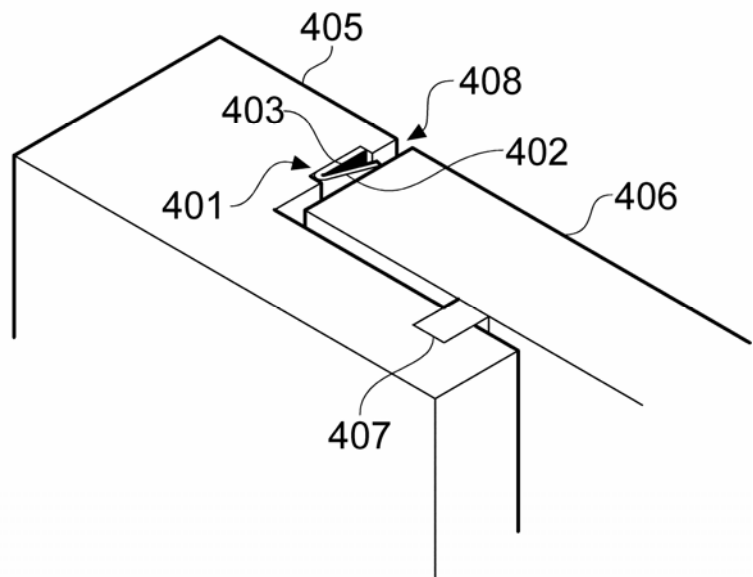

Fig. 3



**Client's Letter**

Dear Mr Thriplewell,

We would like you to obtain the best protection for all the embodiments of our invention. As you know we manufacture seals that can be remotely activated. We also offer fire protection systems that include our seals. Additionally an important part of our business is the modification of existing intumescent seals. We add electrical heating means to them, enabling them to be remotely activated. Please ensure that this activity is also covered by the new claim set you file.

Thank you in advance for your work.

Regards,

Easy Sealy