

EUROPEAN QUALIFYING EXAMINATION 2003

PAPER B ELECTRICITY / MECHANICS

This paper comprises:

- | | |
|--|---------------------|
| * Description of the Application | 2003/B(E/M)/e/1-4 |
| * Claims | 2003/B(E/M)/e/5 |
| * Drawings of the Application | 2003/B(E/M)/e/6-7 |
| * Communication | 2003/B(E/M)/e/8-9 |
| * Document D1
(State of the Art) | 2003/B(E/M)/e/10-11 |
| * Drawing of Document D1
(State of the Art) | 2003/B(E/M)/e/12 |
| * Document D2
(State of the Art) | 2003/B(E/M)/e/13 |
| * Drawing of Document D2
(State of the Art) | 2003/B(E/M)/e/14 |
| * Client's Letter | 2003/B(E/M)/e/15 |

DESCRIPTION OF THE APPLICATION

The invention relates to a steam ironing system comprising a heatable sole plate having an ironing surface for contacting fabric to be ironed.

5

In prior art steam irons, steam is emitted onto the fabric to be ironed. For this purpose, an evaporation chamber in contact with the heatable sole plate is provided. A supply conduit conveys water from a water tank to the sole plate through the evaporation chamber. The steam produced in the evaporation chamber exits the iron through
10 openings in the ironing surface of the sole plate. It is to be understood in this application that steam is vaporized water in which tiny water droplets are distributed.

The water tank is usually mounted above the internal surface of the sole plate. The water tank is connected at its lowest point via a valve to the evaporation chamber. The
15 valve controls the water supply to the evaporation chamber.

A disadvantage associated with this arrangement is that the positioning and the dimensioning of the water tank and the supply conduit are critical to ensure that sufficient water is conveyed under the effect of gravity into the evaporation chamber, so
20 to provide an uninterrupted production of steam. Hence, the flexibility in positioning the water tank is limited. Furthermore it is difficult in these prior art devices to achieve a sufficient water pressure, particularly when the level of water in the water tank is low.

For a larger reservoir of water and a greater water pressure, external water tanks are
25 known in the art. However, these external water tanks have to be positioned higher than the steam iron in order to provide a reliable water supply.

It is therefore an object of the invention to provide a steam ironing system with a water supply to the evaporation chamber regardless of the position and the dimensions of the water tank.

5 This object is achieved by the steam ironing system according to the appended claim 1. A pump ensures that water is reliably driven through the supply conduit to the evaporation chamber regardless of the position and dimensions of the water tank. This allows, for example, to have an external water tank placed lower than the sole plate.

10 Further advantageous embodiments are the subject of the dependent claims. The provision of a pre-evaporation chamber according to claim 2 enables the production of a larger amount of steam. The provision of a bypass conduit according to claim 3 enables to increase and to control the degree of humidity of the steam. Claims 4 and 5 define alternatives for the humidity control of the steam.

15 The invention is described hereafter with reference to the appended drawings.

Fig. 1 is a cross sectional view of a steam iron according to the invention.

20 Fig. 2A and 2B are schematic views of further improvements of the steam iron of Fig. 1.

The steam iron 10 according to the invention comprises a housing 1. A water tank 2, as shown in Fig. 1, is located inside the housing 1, although the water tank 2 may also be located outside the housing 1 as an external water tank, as shown in Fig. 2A and 2B.

25 The water tank 2 in Fig. 1 is fillable through a port 3. A supply conduit 4 provides the fluid communication between the water tank 2 and an evaporation chamber 12. The evaporation chamber 12 is in contact with a sole plate 5 heated by an electric heating resistor 8.

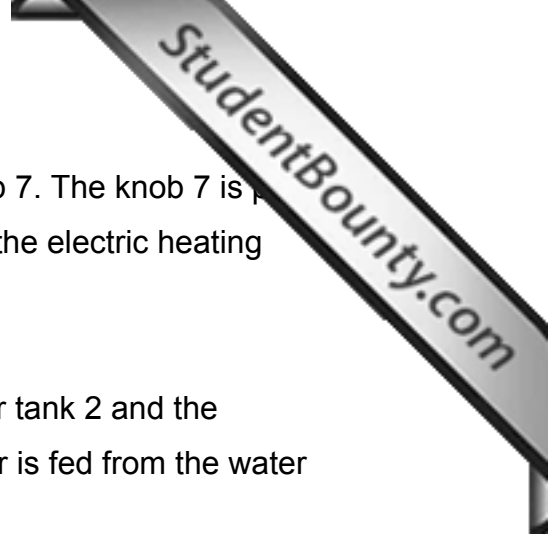

The temperature of the sole plate 5 can be selected by a knob 7. The knob 7 is a control device 9 which controls the electrical power supply to the electric heating resistor 8.

5 A pump 6 is located in the supply conduit 4 between the water tank 2 and the evaporation chamber 12. When the pump 6 is activated, water is fed from the water tank 2 into the evaporation chamber 12.

10 Steam is generated in the evaporation chamber 12. When the sole plate 5 is heated, water conveyed into the evaporation chamber 12 is vaporised by the heated walls of the sole plate 5. The heated walls at least partially surround the evaporation chamber 12. Hence, the dimensions of the evaporation chamber 12 are limited by the dimensions of the sole plate 5. The steam then passes through channels located within the sole plate 5 and exits the steam iron 10 through openings 14. The evaporation chamber 12 is
15 arranged such that the steam produced is distributed uniformly between the openings 14.

The heating power of the electric heating resistor 8 is used both for heating the sole plate 5 and for vaporizing water in the evaporation chamber 12. The amount of steam
20 generated is therefore dependent on the heating power not needed for heating the sole plate 5.

As shown in Fig. 2A and 2B, a pre-evaporation chamber 15 is provided as a further improvement. It is located in series between the pump 6 and the evaporation chamber 12.
25 This pre-evaporation chamber 15 has its own electric heating resistor 8' exclusively used to produce steam. Furthermore, the dimensions of the pre-evaporation chamber 15 are not constrained by the dimensions of the sole plate 5. Therefore, a larger amount of steam can be made available when compared to the arrangement without a pre-evaporation chamber 15.

30 The pre-evaporation chamber 15 produces steam with a low degree of humidity. It has been found that, for a good ironing result of certain types of fabrics, the degree of humidity of the steam is an important parameter.

In order to increase and to control the humidity of the steam which leaves the steam iron 10, a bypass conduit 16 is provided. It bypasses the pre-evaporation chamber 15, as shown in Fig. 2A and 2B, and feeds into the supply conduit 4 between the pre-evaporation chamber 15 and the evaporation chamber 12. Alternatively, the bypass conduit 16 may feed directly into the evaporation chamber 12. As a result, water pumped directly from the water tank 2 through the bypass conduit 16 is mixed with the steam coming from the pre-evaporation chamber 15. Generally, a bypass conduit 16 allows steam produced in the pre-evaporation chamber 15 to be humidified before leaving the steam iron 10.

10

In Fig. 2A the pump 6 is located between the water tank 2 and the bypass conduit 16. A valve 18 is further placed in the bypass conduit 16. In this arrangement the pump 6 feeds water into both the supply conduit 4 with the pre-evaporation chamber 15 and into the bypass conduit 16. With the valve 18 it is possible to control the amount of water which is mixed with the steam from the pre-evaporation chamber 15. A further valve 18' may be placed in the supply conduit 4 before the pre-evaporation chamber 15. The supply of water to the pre-evaporation chamber 15 and to the bypass conduit 16 can thus be independently controlled by opening and closing the valves 18 and 18'.

15

In Fig. 2B the bypass conduit 16 additionally bypasses the pump 6. The bypass conduit 16 has a further pump 19. The two pumps 6 and 19 ensure an independent control of the supply of water to the pre-evaporation chamber 15 and to the bypass conduit 16.

20

The opening and closing of the valves 18 and 18' and the activation of the pumps 6 and 19 may be also controlled by the control device 9.

25

The water tank 2, the supply conduit 4 with the pre-evaporation chamber 15 and the bypass conduit 16 shown in Fig. 2A and 2B in the dashed box are located outside the housing 1 of the steam iron 10. However, these elements may also be integrated into the housing 1 of the steam iron 10.

30

Claims

1. A steam ironing system comprising a heatable sole plate (5) with an ironing surface for contacting fabric to be ironed, a water tank (2), an evaporation chamber (12) and a supply conduit (4) for conveying water from the water tank (2) to the sole plate (5) via the evaporation chamber (12), wherein the evaporation chamber (12) is in contact with the sole plate (5) and is connected to openings (14) in the ironing surface of the sole plate (5) for allowing steam to exit, characterised in that the steam ironing system comprises a pump (6) in the supply conduit (4).
2. The steam ironing system according to claim 1, wherein a pre-evaporation chamber (15) is located in the supply conduit (4) between the pump (6) and the sole plate (5).
3. The steam ironing system according to claim 2, wherein it additionally comprises a bypass conduit (16) to bypass the pre-evaporation chamber (15).
4. The steam ironing system according to claim 3, wherein the pump (6) is located between the water tank (2) and the bypass conduit (16) and wherein a valve (18) is located in the bypass conduit (16).
5. The steam ironing system according to claim 3, wherein the bypass conduit (16) additionally bypasses the pump (6) and wherein a further pump (19) is located in the bypass conduit (16).

DRAWINGS OF THE APPLICATION

1/2

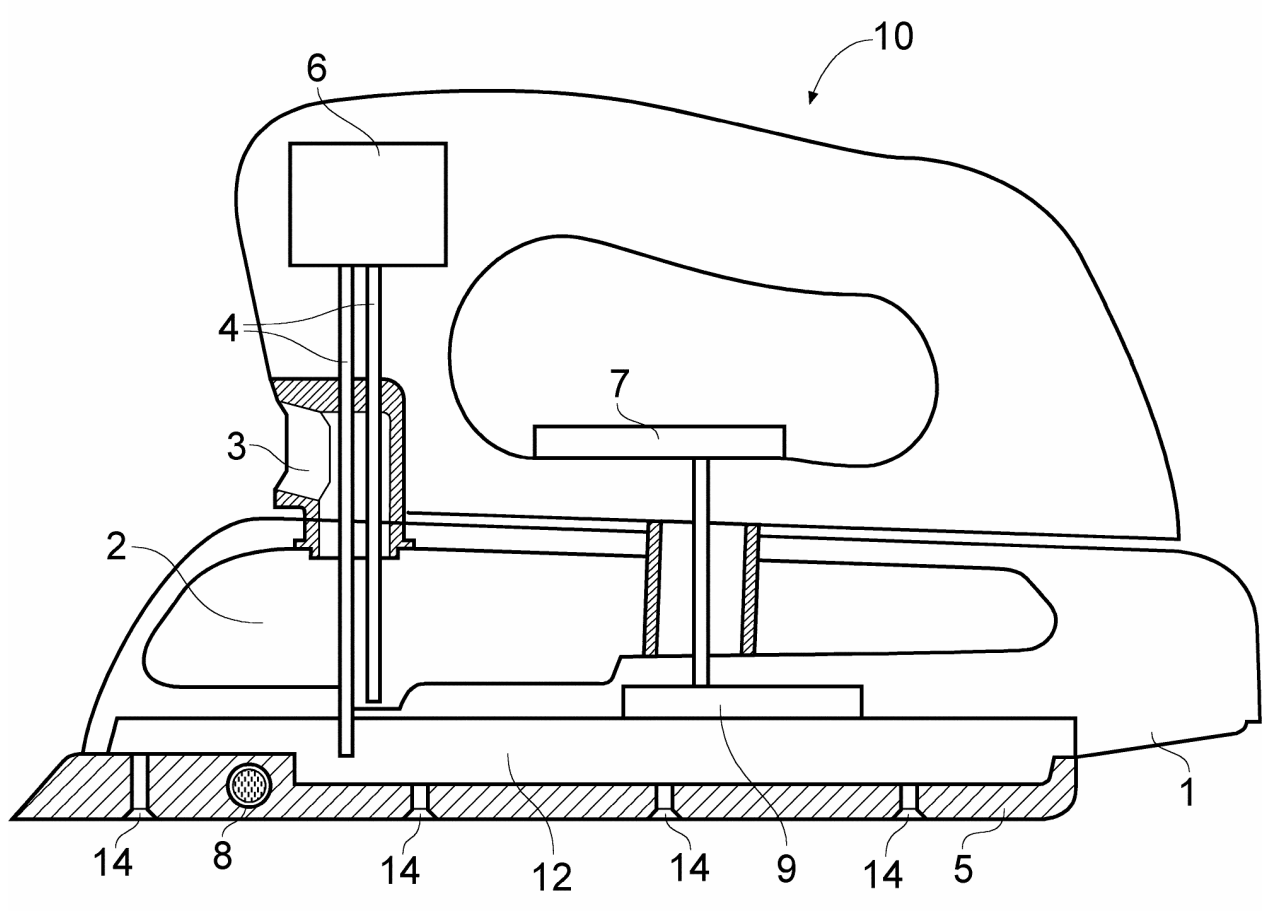

Fig. 1

DRAWINGS OF THE APPLICATION

2/2

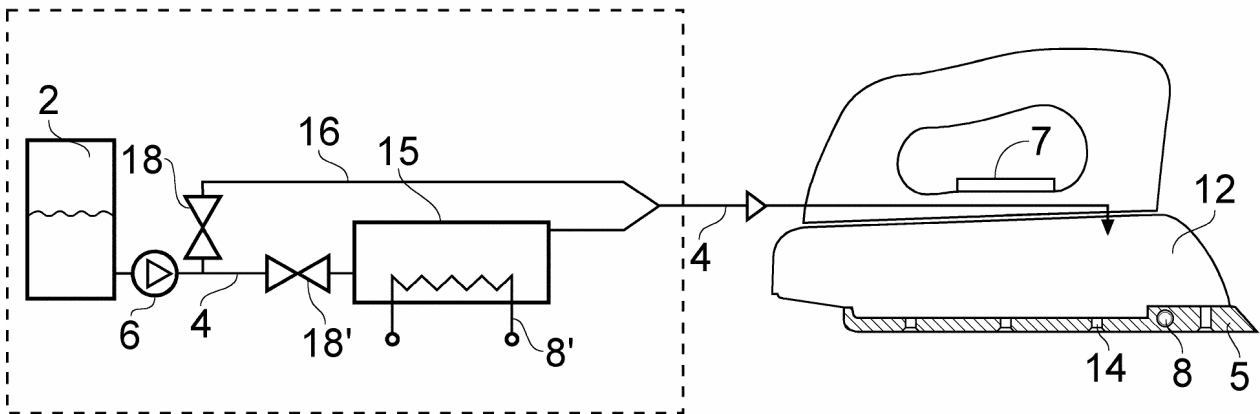
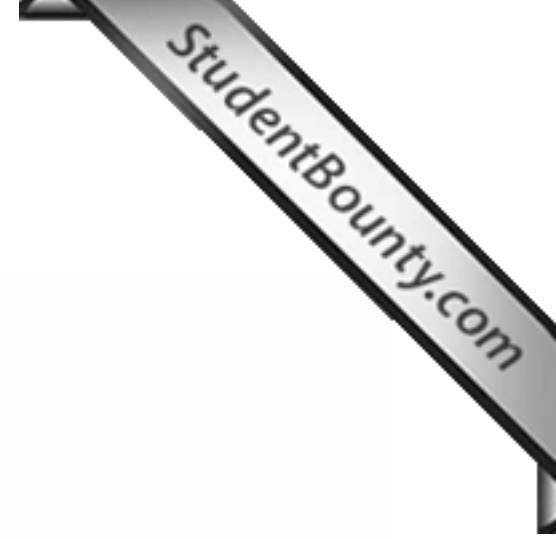

Fig. 2A

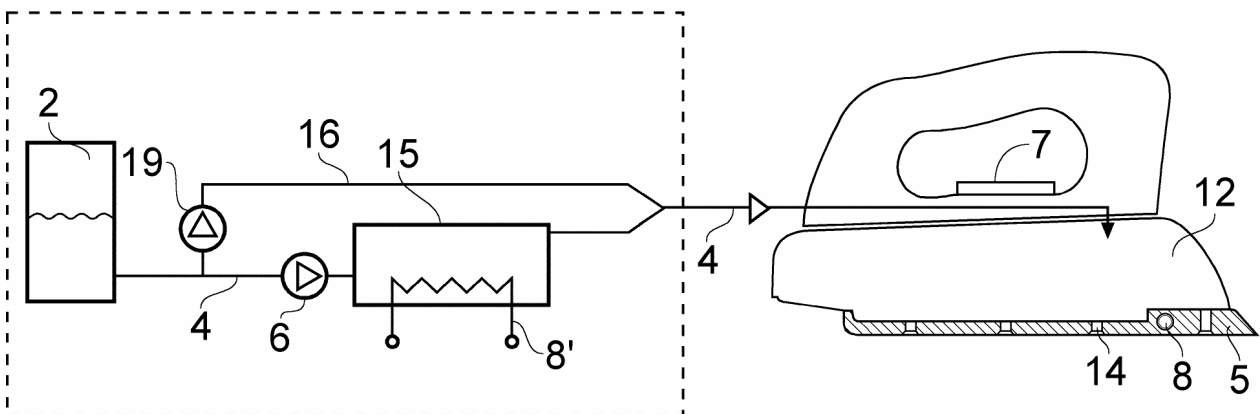

Fig. 2B

Communication

1. D1 and D2, which were both published before the priority date of the present application, are referred to in this communication.
2. Claim 1 is not allowable under Art. 52(1) EPC since its subject matter is not new in the sense of Art. 54(1) EPC with respect to D1. D1 discloses (figure 1) a steam ironing system comprising a heatable sole plate (2) with an ironing surface for contacting fabric to be ironed, a water tank (14), an evaporation chamber (18) and a supply conduit (20) for conveying water from the water tank (14) to the sole plate (2) via the evaporation chamber (18), wherein the evaporation chamber (18) is in contact with the sole plate (2) and is connected to openings (22) in the ironing surface of the sole plate (2) for allowing steam to exit, wherein the steam ironing system comprises a pump (16) in the supply conduit (20).
3. The subject matter of claim 2 does not meet the requirements of Art. 52(1) EPC since it is not new in the sense of Art. 54(1) EPC, for the following reasons: D1 also discloses a pre-evaporation chamber located as defined in claim 2, (D1, penultimate paragraph: pre-heating chamber).
4. The subject matter of claim 3 does not meet the requirements of Art. 52(1) EPC since it lacks inventive step as defined in Art. 56 EPC for the following reasons: The closest prior art is considered to be D1. The subject-matter of claim 3 differs from D1 in that a bypass conduit which bypasses the pre-evaporation chamber is claimed. The problem to be solved is to provide a steam ironing system which can humidify the fabric to be ironed. D2 discloses a bypass conduit (20), bypassing a boiler (8) which solves the above problem. The boiler (8) has its own heating resistor and is not in contact with the sole plate (3). The boiler (8) therefore fulfils the same function as the pre-evaporation chamber of D1. In order to solve the above problem

the person skilled in the art would incorporate the bypass conduit known from D1 into the steam ironing system of D1 and thereby arrive at the subject matter of claim 3 without having made an inventive step.

5. The subject-matter of claim 4 does not meet the requirements of Art. 52(1) EPC since it lacks inventive step as defined in Art. 56 EPC for the following reasons: The arrangement of the pump and the valve according to claim 4 is also known from D2 (see the pump 17 in Fig. 1 and the switching valve 22 in Fig. 2A and 2B of D2).
6. The subject-matter of claim 5 seems not to be anticipated by the available prior art.
7. The applicant is requested to submit an amended set of claims, which takes account of the above comments. The applicant should also indicate and justify in the letter of reply, on the one hand, the difference of the subject-matter of the new independent claim vis-à-vis the state of the art and, on the other hand, the inventive significance thereof.
8. The newly submitted independent claim should use the two-part form (R. 29(1) EPC).
9. The applicant is requested to identify clearly in the letter of reply all amendments made in the claims and their basis in the application as filed and to provide additional explanation where necessary.

DOCUMENT D1 (State of the Art)

The invention relates to a steam iron as shown in the appended figure 1. The steam iron comprises a sole plate 2 and a steam generator which converts water into steam. The steam generator comprises a steam chamber 18 which has a bottom wall formed by the sole plate 2. The steam produced in the steam chamber 18 exits through openings 22. The openings 22 are connected to the steam chamber 18 via channels.

For ironing, the user can select a sole plate temperature by turning a knob 8. The sole plate 2 is heated by an electric heating resistor 4. When the user changes to a lower temperature, it takes a considerable time until the sole plate 2 is cooled down to this lower selected temperature, particularly when the steam iron rests on a tray or in heel rest position.

The object of the present invention is to provide a steam iron with reduced cool-down time when a lower temperature has been selected.

To obtain the above object, the steam iron is provided with a control means 10 for comparing the actual temperature of the sole plate 2, sensed by a temperature sensor 6, to the selected temperature. If the actual temperature is higher than the selected temperature, the control means 10 generates an activation signal for a pump 16, which feeds water from a water tank 14 through a feeding line 20 into the steam chamber 18.

The conversion of water to steam in the steam chamber 18 requires large amounts of energy and thereby rapidly cools down the sole plate 2.

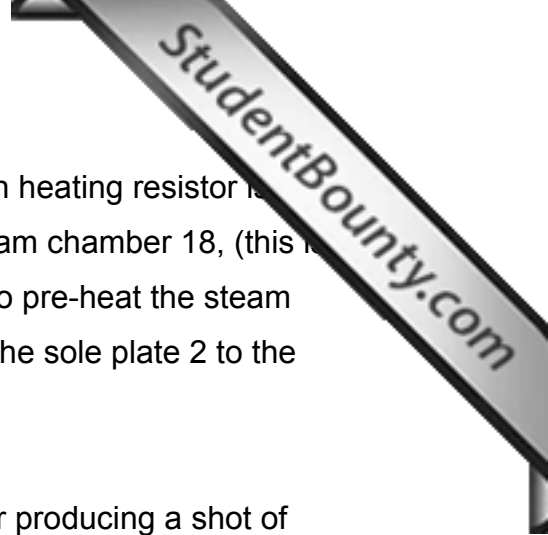

In a further embodiment a pre-heating chamber having its own heating resistor is located in the feeding line 20 between the water pump 16 and the steam chamber 18, (this is shown in Fig. 1). The pre-heating chamber generates steam to pre-heat the steam chamber 18, thereby reducing the time necessary to heat up the sole plate 2 to the selected temperature.

The steam generator can also be used for steam ironing or for producing a shot of steam. The control means 10 sends activation signals of suitable duration to the water pump 16 depending on the amount of steam required. The steam chamber 18 ensures that substantially the same amount of steam is supplied to each of the openings 22.

DRAWING DOCUMENT D1

1/1

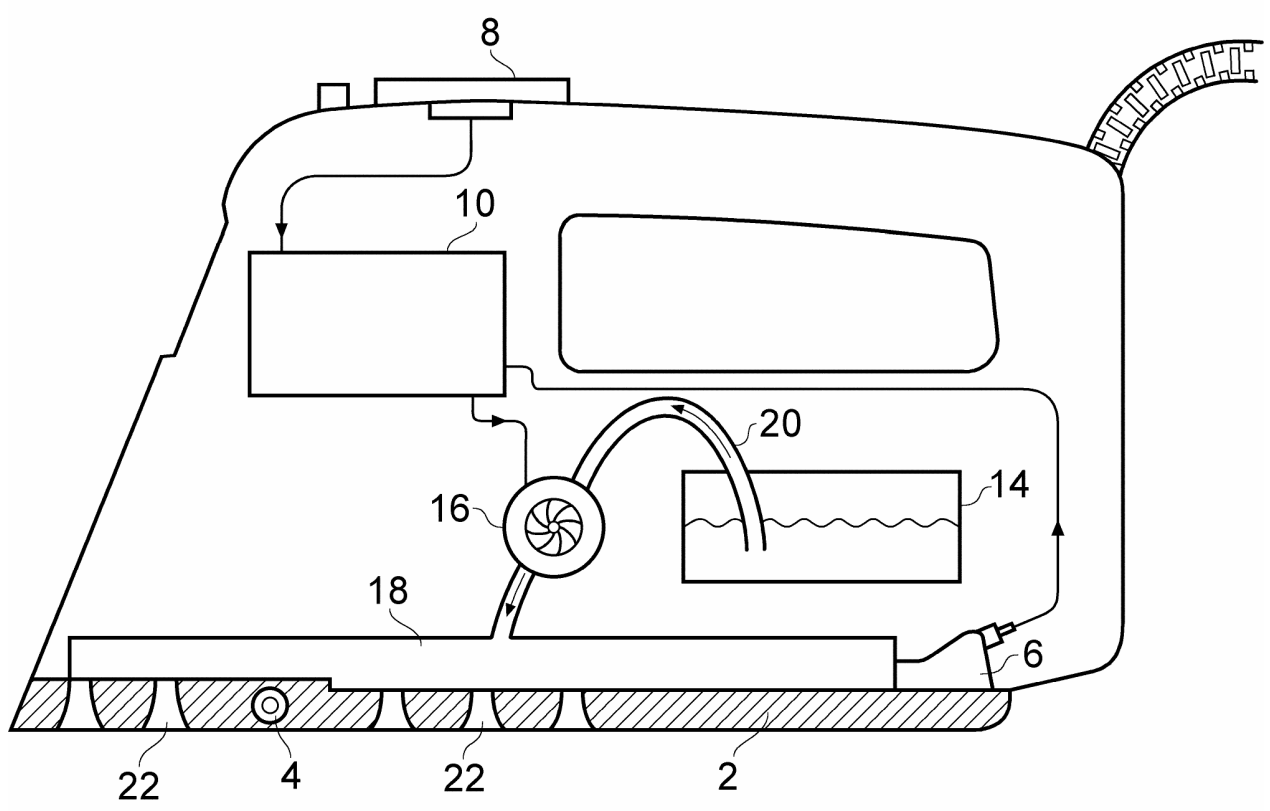

Fig. 1

DOCUMENT D2 (State of the Art)

The appended Fig. 1 shows a steam ironing system. A steam iron 2 has a sole plate 3 heated with an electric heating resistor to a desired temperature. Water 14 from a water tank 12 is delivered to a boiler 8 by a pump 17. Steam generated in the boiler 8 passes through a steam conduit 6 and leaves the steam iron 2 through openings 9 and 9' in the sole plate 3. The boiler 8 has its own electric heating resistor and can generate a large amount of steam.

10 The boiler 8 and the water tank 12 are shown in Fig. 1 as being external to the housing of the steam iron 2. However, the boiler 8 and/or the water tank 12 may also be located inside the housing whilst still achieving the advantages of the present steam ironing system.

15 In the steam ironing system a water conduit 20 bypasses the boiler 8. As shown in Fig. 1, the water conduit 20 starts downstream of the pump 17 and feeds into the front part of the sole plate 3.

20 Fig. 2A and 2B show details of the front part of the sole plate 3. The foremost opening 9' can be connected either to the water conduit 20 or to the steam conduit 6 by means of a switching valve 22. In its initial state, as shown in Fig. 2A, valve 22 is positioned such that it exclusively allows supply of steam to the foremost opening 9' via the steam conduit 6.

25 A button 4, provided on the housing, may be activated to switch the valve 22 into the position shown in Fig. 2B. In this position, the valve 22 exclusively allows the supply of water to the foremost opening 9'. Depending on the temperature of the sole plate 3, the water may partially vaporise in the sole plate 3 at the foremost opening 9'. Thus the fabric to be ironed can be humidified at the front part of the sole plate 3. This is particularly useful for ironing areas of the fabric which are only accessible by the front part of the sole plate 3, e.g. the inside of pockets.

30

DRAWING DOCUMENT D2

1/1

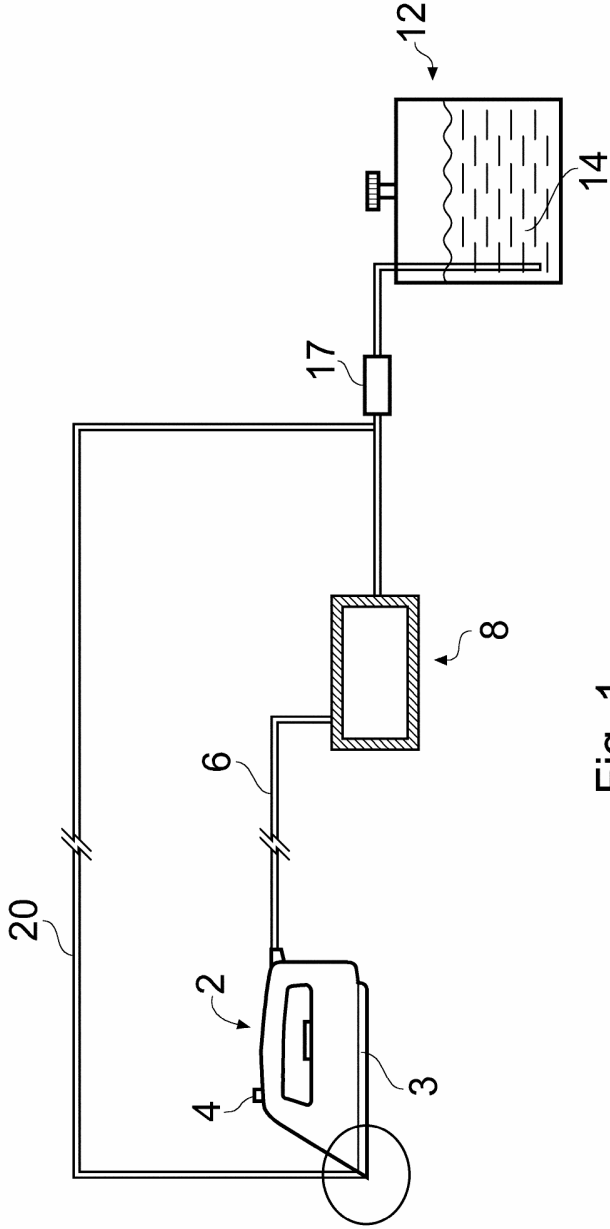

Fig. 1

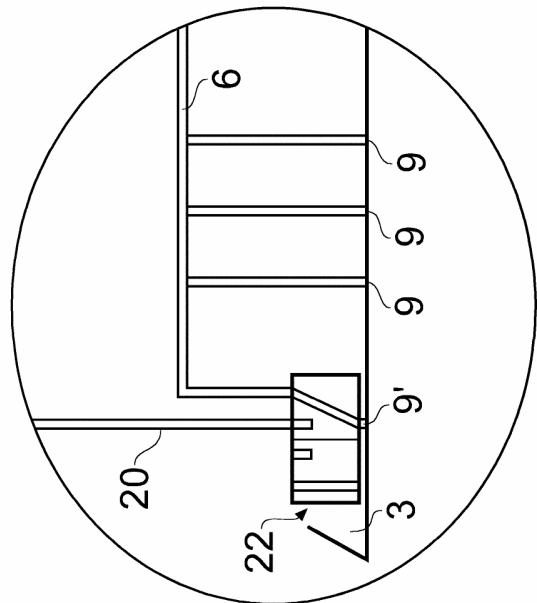

Fig. 2A

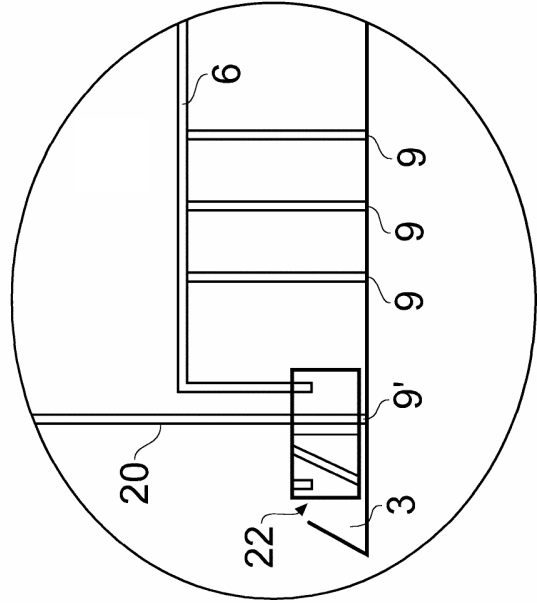
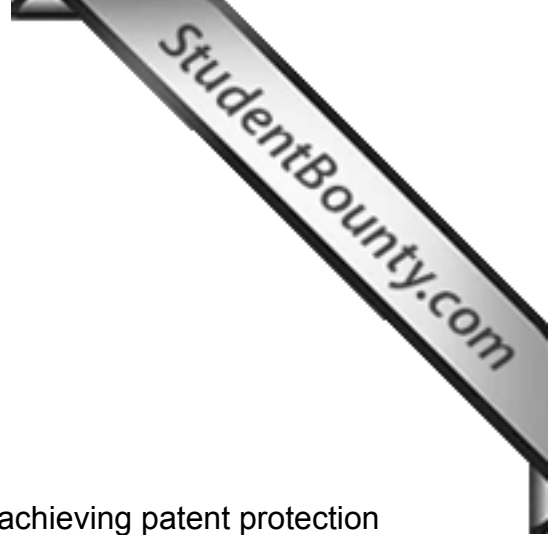

Fig. 2B



CLIENT'S LETTER

Dear Madam/Sir,

In reply to your letter we confirm that we are still interested in achieving patent protection for our new steam iron, despite the communication of the European Patent Office.

Our steam iron produces large quantities of humidified steam and therefore achieves an improved ironing effect. This improved effect has been remarked upon by our test persons with very positive comments.

Our Research and Development department is currently investigating which of the described embodiments is best. Therefore, please take all the necessary steps to achieve the broadest possible protection for our invention.

Yours sincerely,

Mr V.A. Pour
S-Team Ltd.