EUROPEAN QUALIFYING EXAMINATION 2001

PAPER B ELECTRICITY / MECHANICS

This paper comprises:

- | | |
|---|---------------------|
| * Description of the Application | 2001/B(E/M)/e/1-4 |
| * Claims | 2001/B(E/M)/e/5 |
| * Drawings of the Application | 2001/B(E/M)/e/6-7 |
| * Communication | 2001/B(E/M)/e/8-9 |
| * Client's Letter | 2001/B(E/M)/e/10 |
| * Document DI (State of the Art) | 2001/B(E/M)/e/11 |
| * Drawings of Document DI
(State of the Art) | 2001/B(E/M)/e/12 |
| * Document DII (State of the Art) | 2001/B(E/M)/e/13-14 |
| * Drawings of Document DII
(State of the Art) | 2001/B(E/M)/e/15 |
| * Document DIII (State of the Art) | 2001/B(E/M)/e/16-17 |
| * Drawings of Document DIII
(State of the Art) | 2001/B(E/M)/e/18 |

DESCRIPTION OF THE APPLICATION

This invention relates to switches and particularly to a switch control device.

DI describes a resilient switch control device that provides a tactile feedback to the operator. The switch control device includes upper and lower collapsible portions that enable two distinct phases
5 of movement. The two phases of movement contribute to providing the tactile feedback. However, the height of the device, which results from the arrangement of upper and lower collapsible portions, means that the arrangement is not suitable for applications where a low profile is needed.

The aim of the invention is to provide a low profile switch control device.

10

The invention provides a switch control device comprising first and second annular spring portions. One of the annular spring portions is configured to activate before the other. The second annular spring portion is arranged coaxially around the first.

15 The use of first and second annular spring portions that operate at different instances and are arranged coaxially with respect to one another, enables the provision of good tactile feedback in a low profile configuration. The coaxial arrangement of the first and second spring portions also facilitates the manufacture of an integral switch control device from an elastomeric moulding.

20 By arranging the first and second spring portions coaxially with respect to a protrusion, a stable switching action can be provided, without lateral movement of the control device. An annular locating abutment between the first and second spring portions is arranged to contact a base layer during operation. Reliable switching is ensured by a snap switching action. The invention also provides a push button switch and a keyboard.

The invention will be more particularly described by reference to the accompanying drawings, which:

5 Figures 1a, 1b, 1c, 1d and 1e are partial sectional views of an embodiment of a switch control device according to the invention, shown in progressive stages of axial depression;

Figure 2 depicts a sectional view of a switch assembly including a switch control device; and

Figure 3 is a perspective view of an elastomeric pad having multiple switch control devices integrally joined together for use in a keyboard.

10 In its rest, ie non-depressed position, the switch control device shown at 10 in Fig. 1a is formed of a generally dome-shaped elastomeric moulding including a central portion 12, a first annular spring portion 14 and a second annular spring portion 16. The switch control device 10 is also provided with a lower marginal flange portion 18 to facilitate mounting in a switch assembly. The
15 switch control device 10 is preferably formed from a suitable elastic polymeric material (herein described as "elastomeric") such as natural or synthetic rubber or thermoplastic elastomers, eg silicone rubber, polyurethane, etc. The switch control device 10 is preferably integrally formed using any suitable fabrication process such as compression moulding or injection moulding.

20 The central portion 12 of the control device is provided with movable switch actuation means such as a protrusion 22. The protrusion 22 extends downwardly from a planar portion 24 to the extent desired. The central portion 12 may also be provided with an upstanding ring 26 on which a key 46 is mounted, as shown in Figure 2.

25 Attached to the central portion 12, and arranged coaxially therewith, is a first annular spring portion 14, which deforms in the shape of an S during operation to provide a snap action, resulting in a tactile sensation to the operator and a predefined switching pressure. The first spring portion 14 may have any shape that provides a snap action upon axial depression of the control device.

Attached to the first spring portion 14, and coaxially arranged therewith, is second annular spring portion 16. This second spring portion 16 has an outer wall 28 that extends substantially vertically forming a cylinder about the axis of the control device, and a portion 30 having a cross-section with an inverted U-shape. The connection of the first and second annular spring portions preferably forms an annular abutment 20 shown in Figure 1a and further defines a groove 29a. The outer wall 28 is thus able to support, via portion 30, the first annular spring portion 14 and the central portion 12 in a stable fashion to prevent lateral movement of the control device 10.

A representative assembly of a switch 35 including the control device of the invention in an associated switch housing 42 is shown in Figure 2. This includes a key 46 that operates on the ring 26. The key 46 is retained within the switch housing 42 by means of a flange 48. Also represented in Figure 2 is an example of a contact in the form of a capacitive, membrane switch. The capacitive, membrane switch comprises a support plate 54. A first dielectric membrane 55 is arranged on the support plate 54, having a pair of electrically conductive areas 56, 57 formed on opposite sides of the membrane 55. A second dielectric membrane 58 with a conductive area 59 is arranged such that the conductive area 59 is placed over the conductive area 57 and spaced from this by a spacer sheet 60. An aperture 61 is formed in spacer sheet 60 allowing the conductive areas 57 and 59 to make contact when the switch control device is activated. The conductive areas 56, 57 and 59 form plates of a capacitor of which the outer plates are connected to electrical detection circuitry (not shown). By depression of the key 46, the conductive areas 57 and 59 come into contact and thereby change the capacitance, which is registered by the detection circuitry.

The operation of the switch control device will be described hereinafter.

Figure 1a shows the rest, ie non-depressed state of the switch control device. When a user depresses the key 46, the central portion 12 of the switch control device will be displaced axially downwardly as illustrated in Fig. 1b. This causes wall 28 and portion 30 to progressively deform as shown in Figs. 1b-1d.

When the switch control device reaches the state shown in Figure 1d, the annular abutment is brought into contact with the top surface 32 of membrane 58 shown in Figure 2.

As the key is further depressed from the state shown in Figure 1d, the sidewall of first spring portion 14 flexes and undergoes a snap transformation, the result of which is shown in Figure 1e. During the snap transformation, the spring portion 14 causes a downward movement of central portion 12 with protrusion 22. At the same time, annular abutment 20 moves upwards. The snap transformation thereby ensures a predetermined minimum switching force. This force acts downwardly on the membrane 58 of the switch. This minimum switching force is chosen so as to provide reliable switching action, by ensuring that the membrane is sufficiently depressed. During the snap transformation, the resistance force felt by the operator suddenly diminishes as the central portion 12 is displaced. This indicates to the operator that contact is being made.

After activation of the switch, lessening pressure from the finger of the operator allows the switch control device to revert to its original position, as shown in Figure 1a.

Although Figures 1 and 2 show a single device, multiple such devices can be integrally formed in an elastomeric pad 19 as shown in Figure 3. Such a pad 19 finds particular application in the manufacture of keyboards.

Claims

1. A switch control device (10) comprising first and second annular spring portions (14, 16), wherein one of the annular spring portions is configured to activate before the other, characterized in that the second annular spring portion (16) is arranged coaxially around the first annular spring portion (14).
2. A switch control device according to claim 1, comprising a protrusion (22), the first and second annular spring portions being arranged coaxially with respect to the protrusion.
3. A switch control device according to claim 2, further comprising an annular abutment (20) arranged between the first and second annular spring portions.
4. A switch control device according to any preceding claim, configured to provide a snap switching action.
5. A push button switch comprising a membrane switch, and a switch control device (10) according to any preceding claim for operating the membrane switch.
6. A keyboard comprising a plurality of switch control devices (10) according to any one of claims 1 to 4.

DRAWINGS OF THE APPLICATION

1/2

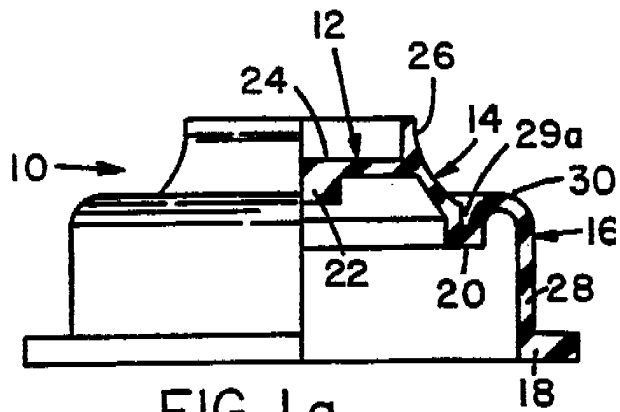

FIG. 1 a

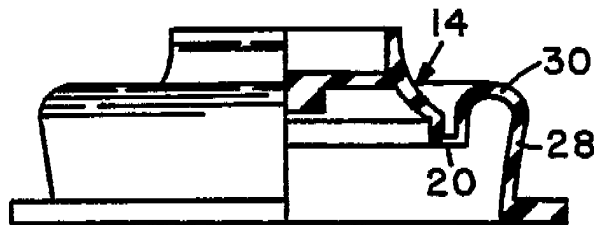

FIG. 1 b

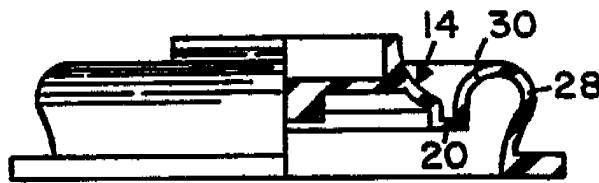

FIG. 1 c

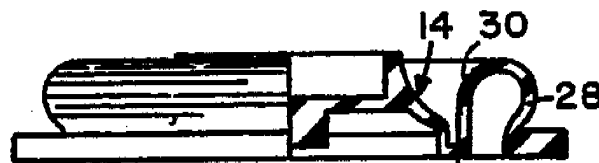

FIG. 1 d



FIG. 1 e

DRAWINGS OF THE APPLICATION

2/2

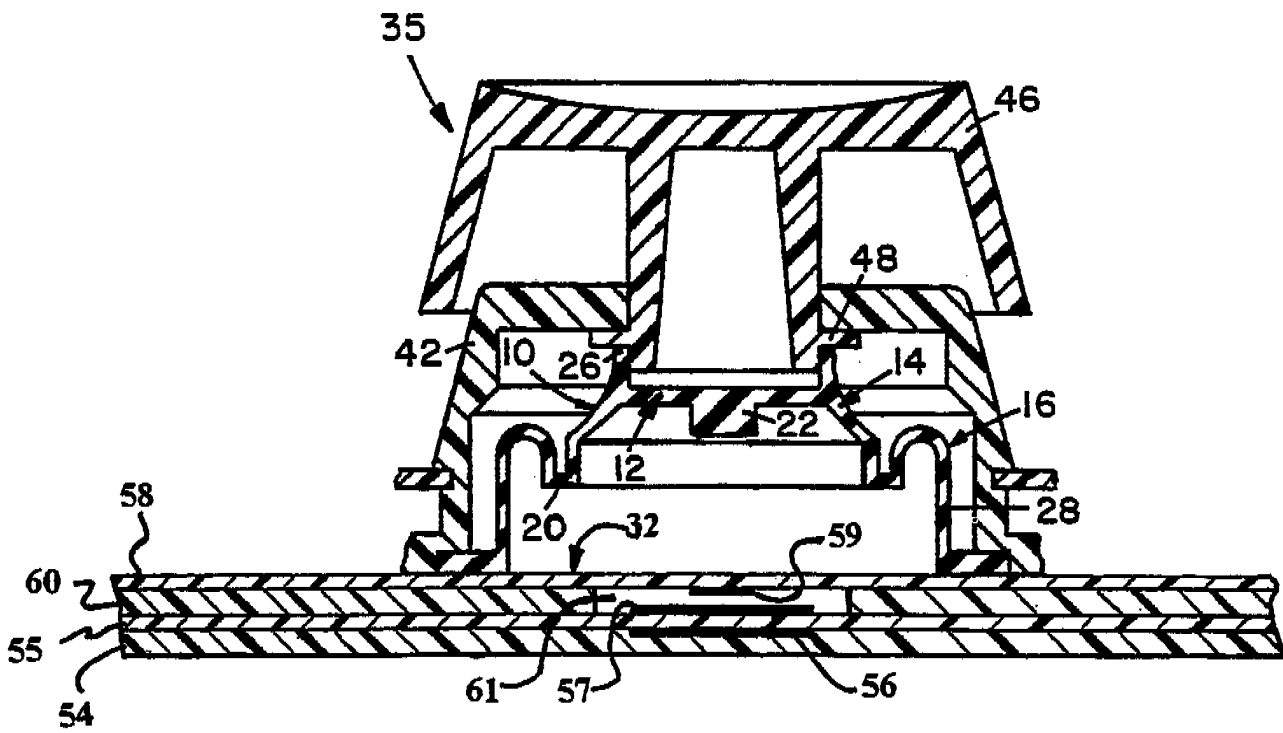

FIG. 2

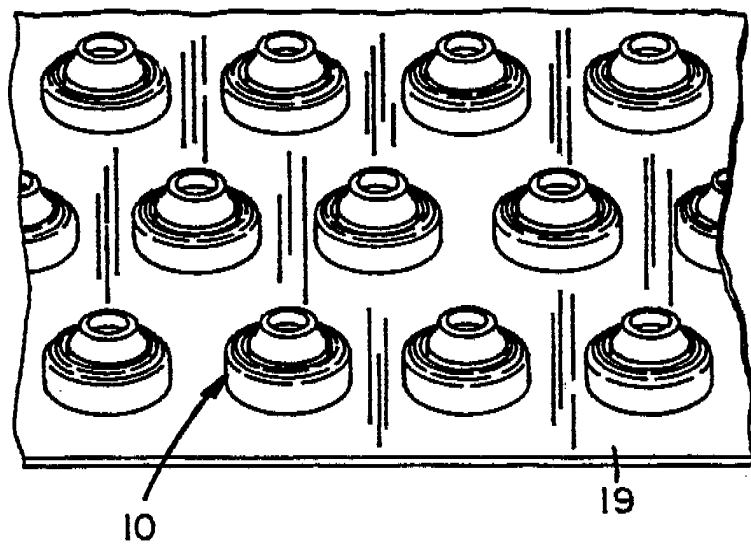

FIG. 3

COMMUNICATION UNDER ARTICLE 96(2) AND RULE 51(2) EPC

The examination is being carried out on the application documents as originally filed.

1. The following pre-published documents are mentioned in this communication:
Document DII; and
Document DIII.
2. The present application does not meet the requirements of Articles 52(1) and 54(1)(2) EPC because the subject matter of claim 1 lacks novelty with respect to both DII and DIII.
3. DII discloses a switch control device with first and second annular spring portions (44, 37). One spring portion (37) is activated before the other one (44). The second spring portion (37) is arranged coaxially around the first spring portion (44).
4. DIII also discloses a switch control device with first and second annular spring portions (16, 17). One spring portion (17) is activated before the other one (16). The second spring portion (17) is arranged coaxially around the first spring portion (16).
5. The subject-matter of claims 2 and 3 lacks novelty with respect to DII, as this also discloses the further features defined in those claims.
6. DIII describes a snap switching action. The subject matter of claim 4, when directly dependent on claim 1, thus lacks novelty with respect to DIII. As it would be obvious to modify the DII switch device to provide the advantages described in DIII, the subject matter of claim 4 does not involve an inventive step (Arts. 52(1) and 56 EPC) in the light of DII and DIII, for all other claim dependencies.

-
7. DII describes a capacitive, membrane switching assembly. The subject matter of claim 6 therefore lacks either novelty or does not involve an inventive step.
 8. DIII describes a keyboard with a plurality of switch control devices. Accordingly, the subject matter of claim 6 also lacks either novelty or does not involve an inventive step.
 9. It is not at present apparent which part of the application could serve as a basis for a new, allowable claim. Should the applicant nevertheless regard some particular matter as patentable, an independent claim including such matter should be filed. The applicant should also indicate and justify in the letter of reply, on the one hand, the difference of the subject matter of the new claims vis-à-vis the state of the art and, on the other hand, the inventive significance thereof.

CLIENT'S LETTER

We have reviewed the examiner's communication. We believe that the reliable switching action of our switch control device is a significant factor in the success of our invention. Please do your best to obtain as broad a protection as possible for this.

DOCUMENT DI

This document describes a switch element such as is used in keyboards of an electrical or electronic apparatus. Figure 1 is a section through a switch element in a rest position. Figure 2 is a section with the switch element in a contacting position.

5 A switch element 1 includes a base foil 2 and an integral resilient section 3 formed from an elastomer (eg silicone rubber). The base foil 2 lies on a base plate 4 formed by an insulator carrying a printed circuit. The switch element 1 lies above a contact position of the circuit. An array of such switch elements 1 forms a keyboard contact pad. The base foil 2 has grooves 5 to enable air to escape on operating the switch element 1.

10

The section 3 includes resilient walls 7 and a pressure plate 8. The pressure plate 8 carries a contact plate 9 for closing contacts (not shown) on the base plate 4, after traversing the distance a between its rest position shown in Figure 1 and the surface of the base plate 4.

15 A hollow body 10 having resilient walls 11 is formed integrally with and above the pressure plate 8. The hollow body 10 encloses a hollow space that is covered by a button 13. The button has an annular element 14 lying against a keyboard cover 15. A protrusion 16 on the button 13 lies at a distance b from the pressure plate 8 in the rest position shown in Figure 1.

20 The stroke of the button 13 thus includes two partial strokes represented by the distances a and b. Figure 2 illustrates the switch element 1 in the contact position. On pressing the button 13, the hollow body 10 firstly deforms (partial stroke b) into the position shown dashed in Figure 1. A somewhat greater force is then needed to deform the resilient section 3 (partial stroke a). The force profile can be varied, for example by giving a particular shape to the hollow body 10 or to
25 the resilient section 3.

DRAWINGS OF DOCUMENT DI (State of the Art)

1/1

Fig. 1

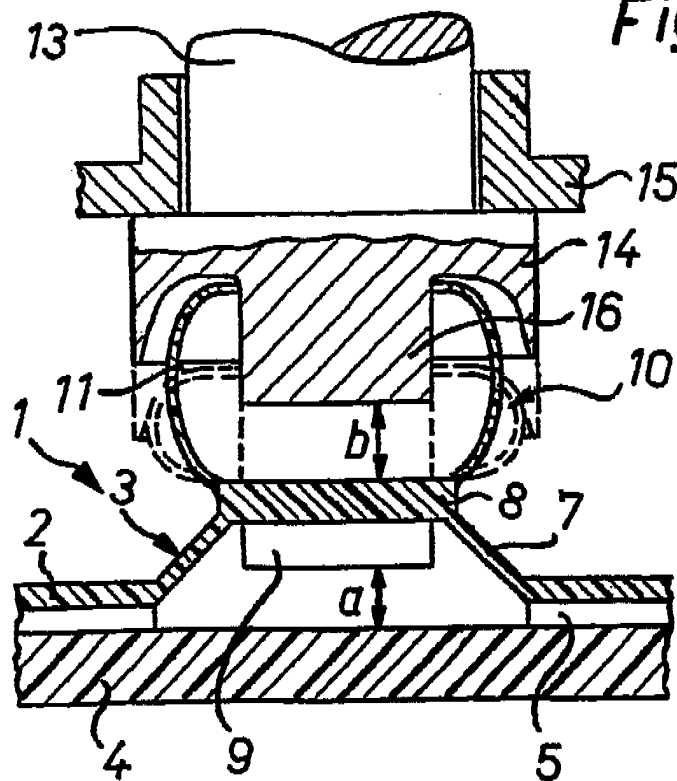
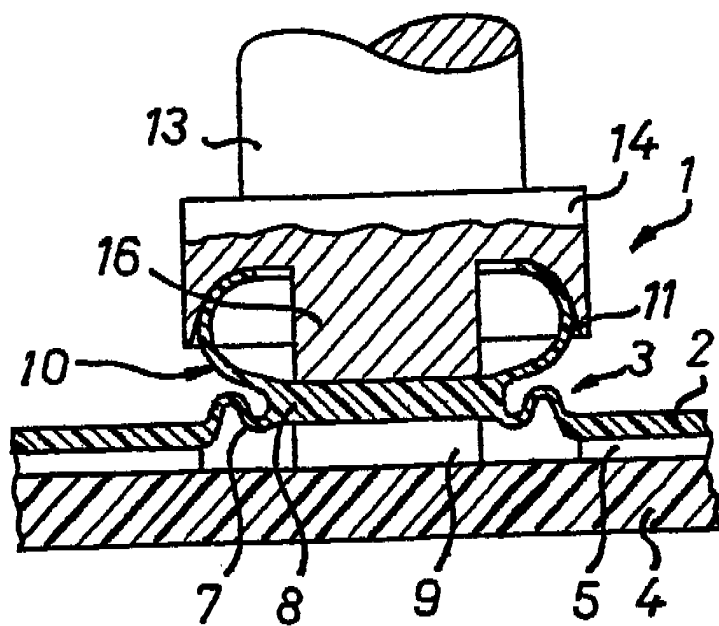

Fig. 2



DOCUMENT DII

Figure 1 is a plan view of an elastomeric push button element 30. Figures 2 and 3 are sectional views in elevation of the element 30 in a rest position and a depressed position, respectively. As well as the element 30, Figures 2 and 3 also represent a push button cap 12 and a base structure which carries a capacitive membrane switching assembly 13.

5

The element 30 is of a generally circular configuration, symmetrical about an axis 27 and comprises a flange 31 having an annular outer portion 32 to be held against the upper surface of the switching assembly 13 by a housing (not shown). The flange 31 also includes a radial web 33 of reduced thickness, created by a groove 34 in the upper surface of the flange.

10

A cylindrical tubular section 35 is connected at its lower end to the web 33. The web 33 is more flexible than the tubular section 35. To achieve this, the wall thickness of the tubular section 35 may be greater than the thickness of the web 33.

15 A hollow frustum section 37 is joined at junction area 38 to the end of the tubular section 35 remote from web 33. A crown comprising a tubular wall 39 sized to fit into an aperture in the cap 12 is formed at the small end of the frustum section 37.

20 An annular stop member 42 that extends downwards a short distance is formed in the frustum section 37. Within stop member 42 and joined to wall 39 is a cup shaped section 44 having a downward projecting actuator 46 at its centre. At rest the actuator 46 projects downwards further than the stop member 42. Thus, as the push button cap 12 is depressed, the actuator 46 comes into contact with the upper surface of the switching assembly 13 before the stop member 42.

25 During pressing of the push button, the element 30 undergoes a number of changes in a predefined order.

1. Firstly, as the user presses the push button cap 12, the junction area 38, the frustum section 37, and the web 33 deform as the actuator 46 moves downward.

2. After the actuator 46 has reached the membrane switching assembly 13, and while user continues to press the push button, the cup-shaped section 44 also deforms, which increases the resistance experienced by the user.
 - 5 3. The downward movement of the push button is stopped when the stop member 42 reaches the switching assembly. This state is represented in Figure 3. At this time, at least a minimum contact pressure, provided by force applied by the user pressing the button, is applied to the membrane switching assembly 13. The minimum contact pressure is defined by the force applied by the user to cause deformation of the frustum section 37 and the cup-shaped section 44.
- 10

Passageways 48 act as vents for the interior of element 30.

DRAWINGS OF DOCUMENT DII (State of the Art)

1/1

Fig. 1

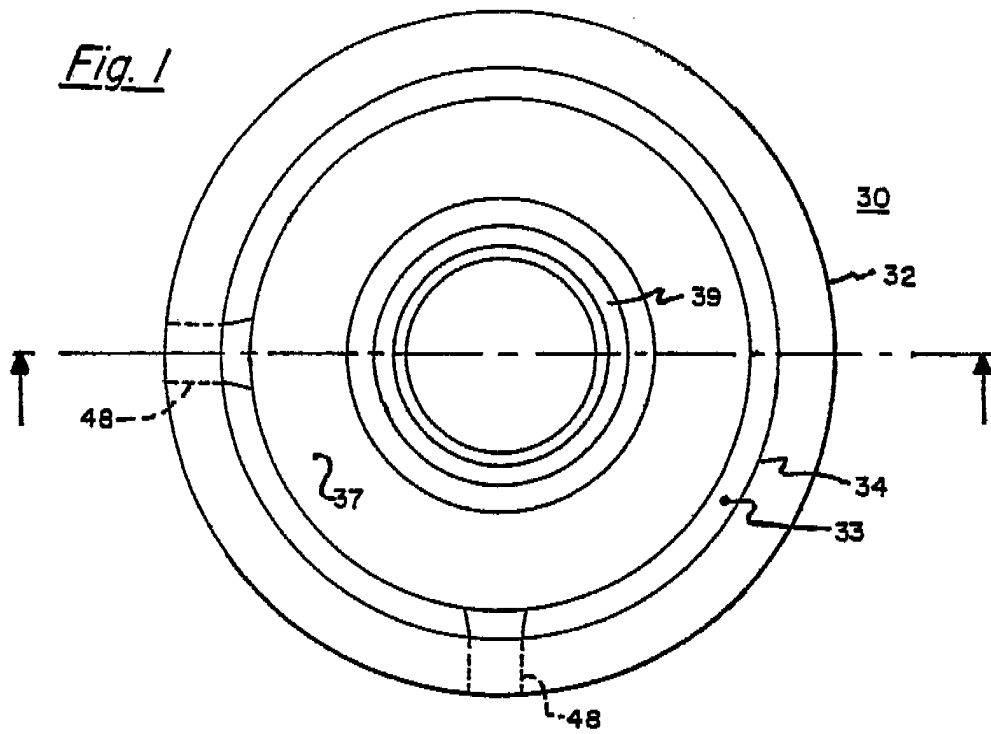

Fig. 2

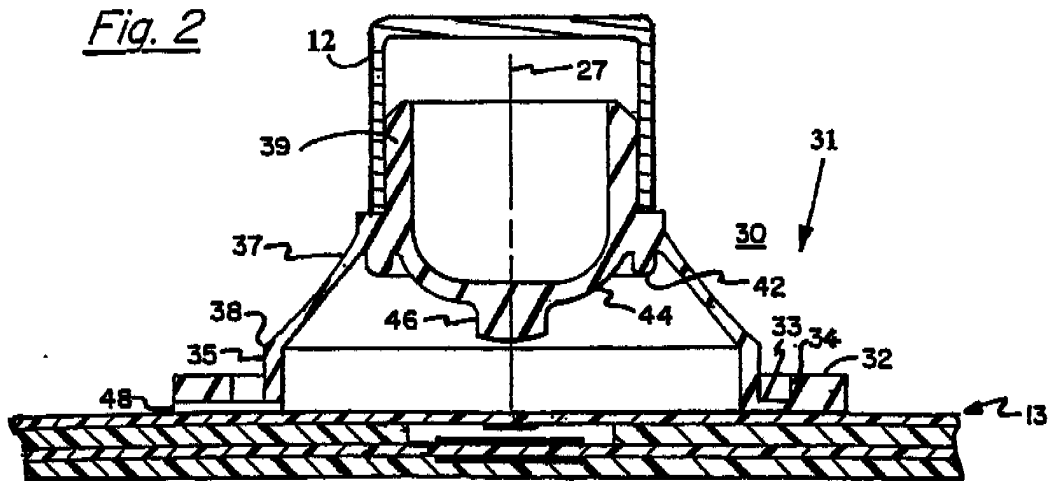
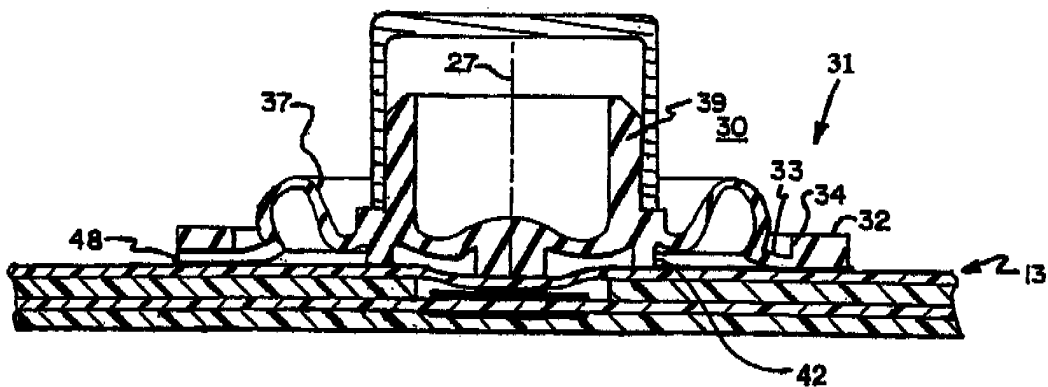

Fig. 3



DOCUMENT DIII

This document describes a push button switch for closing an electrical circuit as the button is depressed by a finger and for opening the circuit as the button is released. The push button is intended for use in a calculator keyboard or the like. It is important for such an application that the push-button switch be simple and inexpensive to manufacture, and capable of being formed
5 as an array of switch elements with a low profile.

A particular aim of this switch design is to provide a reliable switching that minimizes the possibility of contact bounce (ie of multiple contacts on a single actuation).

10 Figures 1a-1e form cross sectional views of an example of the present push button switch during various stages of operation. The push-button switch in Figures 1a-1e comprises a base plate 18 with a pair of fixed contact points 19, 19'. An elastomeric diaphragm cover 11 has a structure including a circular inner zone 16 with a central dished portion 13. A ring-shaped contact zone 14
15 surrounds the circular inner zone 16. On the underside of the ring-shaped contact zone 14 a contact ring 15 is formed from a conductive metal. A ring-shaped outer zone 17 is formed between the contact zone 14 and a peripheral flat portion 12. The inner zone 16 and the outer zone 17 are configured to form spring zones with different resistances to flexing, as will become apparent from the following description. The cover 11 is bonded to the base plate 18 in the area of the peripheral flat portion 12.

20 The various stages of movement during operation of the switch will now be described with reference to Figures 1a-1e.

Figure 1a shows a rest state in which the push-button switch is not depressed.

25 Figure 1b shows a first stage in the operation of the switch in which, following the application of initial downward pressure by a finger on the inner zone 16, the outer zone 17 flexes so that the contact ring 15 makes contact with the contact points 19, 19' on the base plate 18, closing the contact between those contact points 19, 19'.

As shown in Figure 1c, following the application of further downward pressure by a finger on the inner zone 16, the inner zone 16 flexes in turn. By a suitable configuration of the inner zone 16 and the outer zone 17, the strains within both zones and the effect of the air pressure under the cover 11 cause the outer zone 17 to snap upwards. As the outer zone 17 snaps upwards, the contact ring 15 separates away from the contact points 19, 19', opening the circuit between the contact points 19, 19'. At the same time the user feels a momentary slight reduction in the resistance to the applied pressure.

Figure 1d shows a further stage in the operation of the switch, at which the user has depressed the inner zone 16 as far as it can go, so that the underside of the dished portion 13 contacts the base plate 18. It can be seen that during the further depression of the inner zone 16, the contact ring 15 is held away from the contact points 19, 19' maintaining circuit open.

Figure 1e shows a further stage in the operation of the switch, following the finger being removed from the inner zone 16. The inner zone 16 is shown part way during its rise back to the initial position shown in Figure 1a. It can be seen that here also, the contact ring 15 is held away from the contact points 19, 19', thus maintaining the circuit open.

It will be appreciated from the above that the snap action of the outer zone 17 following contact, reduces the risk of contact bounce (ie multiple contacts).

Although Figures 1a-1e show only one switch, it will be appreciated that rows and/or columns of such switches can be readily made in an integrated manner to form a keyboard.

DRAWINGS OF DOCUMENT DIII (State of the Art)

1/1

FIG. 1a

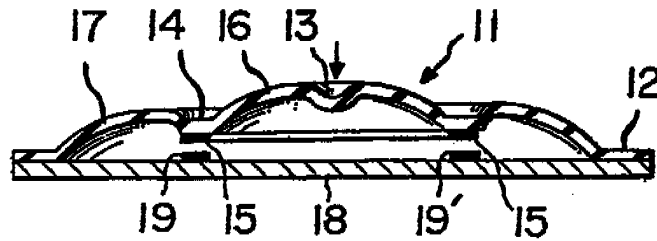

FIG. 1b

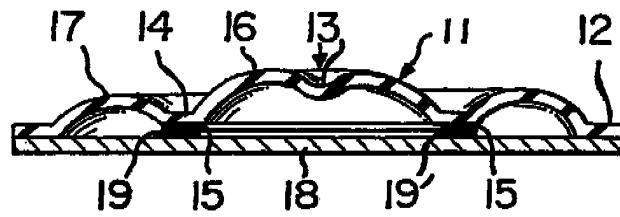

FIG. 1c

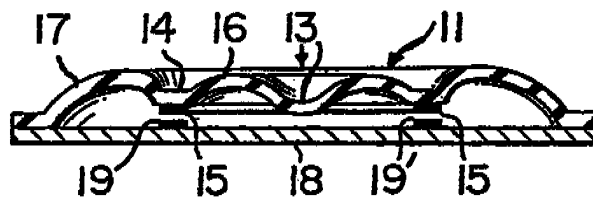

FIG. 1d

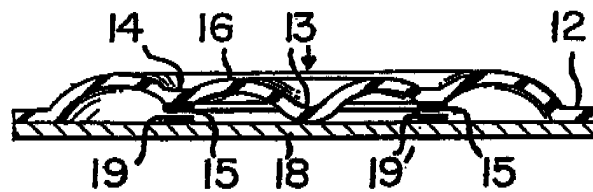

FIG. 1e

