



Europäisches  
Patentamt

European  
Patent Office

Office  
français  
de  
brevets

Europäische  
Eignungsprüfung

European  
qualifying examination

Examen eu-  
ropéen de  
qualification

Prüfungssekretariat

Examination Secretariat

Secrétariat d'examen

StudentBounty.com

## EUROPEAN QUALIFYING EXAMINATION 2000

### PAPER B ELECTRICITY / MECHANICS

THIS PAPER COMPRISES:

- |  |                     |
|--|---------------------|
| * DESCRIPTION OF THE APPLICATION                 | 2000/B(E/M)/E/1-4   |
| * CLAIMS   | 2000/B(E/M)/E/5     |
| * DRAWINGS OF THE APPLICATION                    | 2000/B(E/M)/E/6-8   |
| * COMMUNICATION                                  | 2000/B(E/M)/E/9-10  |
| * DOCUMENT DI (STATE OF THE ART)                 | 2000/B(E/M)/E/11-12 |
| * DRAWING OF DOCUMENT DI<br>(STATE OF THE ART)   | 2000/B(E/M)/E/13    |
| * DOCUMENT DII (STATE OF THE ART)                | 2000/B(E/M)/E/14-15 |
| * DRAWINGS OF DOCUMENT DII<br>(STATE OF THE ART) | 2000/B(E/M)/E/16-17 |
| * CLIENT'S LETTER                                | 2000/B(E/M)/E/18-19 |

## DESCRIPTION OF THE APPLICATION

The invention relates to a mixing device which can be rolled on the ground. It is primarily designed for mixing concrete, but may also be used for mixing other wet or dry materials such as seeds, soil mixes or paint.

- 5 DI describes a concrete mixer according to the preamble of claim 1. This known apparatus has an aperture at one end through which the mixer is filled and emptied. The open construction of the apparatus according to DI is disadvantageous in that the useable volume of the mixer drum is severely limited, since excess mix escapes through the aperture during mixing. Thus the mixer of DI can produce only small batches of concrete relative to the drum volume. Moreover, mixing small batches in a large volume drum does not ensure a continual separation and recombination of the mix during rotation. Hence the mixer of DI is also inefficient.

Another problem with the mixer of DI is that its mixing ribs are fabricated from wooden elements attached by screws to the drum wall. Ground-rolled mixers are subject to extremely rough operating conditions, such as kicking by foot. After prolonged use, parts of the wooden ribs break away from their fixings and contaminate the mix.

The object of the invention is to provide a robust and efficient ground-rolled mixer which, relative to its size, is capable of producing a large well-mixed batch.

This object is achieved by the features of claim 1. Advantageous embodiments of the mixer are described in the dependent claims.

- 25 The mixer drum is a one-piece, blow moulded plastic body with integral mixing ribs. A lid is provided to close the drum aperture. The mix quantity can thereby be significantly increased. Moreover a fully closed drum allows the use of helical mixing ribs, which improve the mixing process by transporting and distributing the mix along the entire length of the drum.

The drawings illustrate an embodiment of the invention.

Fig. 1 is a side elevation of an embodiment of the mixing drum of the invention.

5 Fig. 2 is a side elevation of an embodiment of the lid of the invention.

Fig. 3 is a plan view of the lid of Fig. 2.

Fig. 4 is a cross section on line BB of Fig. 1.

10

Fig. 5 is a simplified perspective view of the embodiments of Figs. 1 and 2.

Fig. 6 shows the elements of Fig. 5 assembled and in use.

The mixing device of Figs. 1-4 comprises a hollow drum 1 with a cylindrical wall 13, the drum being closed at one end 2 and open at the other end 3. Closed end 2 may be slightly concave, as indicated in Fig. 1. The drum is filled in an upright position through open end 3. Open end 3 is closed by a lid 4. The lid has a peripheral rim 9. A thread (not shown) on the lid 4 co-operates with a thread 5 on the cylindrical wall 13 of the drum 1.

The lid 4 may be injection moulded from high density polyethylene. The drum 1 is blow moulded from either polypropylene or high density polyethylene, producing a strong and robust drum with good impact resistance.

25 Mixing ribs 8 are formed on the interior surface of the drum. During rotation of the drum 1, these ribs 8 cause the drum contents to be tumbled and moved in a direction generally towards an end 2,3 of the drum 1, ensuring very efficient mixing. The drum 1 and ribs 8 form a one-piece blow moulded plastic body. The recesses 14 formed by the ribs 8 in the exterior cylindrical wall 13 of the drum are dimensioned to provide hand-holds for rotating the drum by hand, and also for gripping the drum  
30 during emptying. These hand-holds are capable of accommodating four adult fingers up to at least the middle of the finger.

To facilitate entry and extraction of the fingers, the recesses are preferably smooth-walled tapered so that each recess becomes narrower in a direction towards the centre of the drum.

Suitable values for the recess dimensions shown in Fig. 4 are  $D = 50$  mm,  $W_1 = 30$  mm and  
5  $W_2 = 20$  mm.

The drum must be of a size and weight such that it is easily moveable by manual operation alone. Suitable sizes for the drum height (the distance between ends 2 and 3) are about 400-1000 mm, and for the drum diameter about 300-600 mm, although the height should always be greater than the  
10 diameter.

At least one and preferably two, three, four or more mixing ribs 8 are provided. For optimisation of both their mixing and hand-hold functions, the ribs 8 are generally evenly distributed about the circumference and extend along a substantial length of the drum, from the end 2 to a point within about 50 mm from a shoulder 7. At this shoulder 7 a small rebate 10 of about 20 mm extends to the threaded part 5. This rebate accommodates the rim 9 of the lid 4, and allows it to lie flush with the drum wall 13. In that this rebate is small, it also allows easy access to the drum interior for cleaning purposes.

The figures show an embodiment with two ribs 8, each rib having a generally helical form. However, the ribs can be of any suitable configuration, subject to the comments above regarding the recesses. For example, four equally-spaced helical ribs, each having a pitch of four times the height of the drum (i.e. the helix describes one revolution over a distance of four drum heights) have been found to provide particularly satisfactory mixing results. Such an arrangement also presents hand-holds around  
25 the entire external circumference of the drum. This is useful when rotating the drum by hand, particularly when more than one person is involved. An alternative rib/recess configuration that also works, is to have a number of axially-aligned ribs/recesses arranged around the cylindrical wall of the drum.

As mentioned above, the lid 4 provides a rim 9 which when joined to the drum becomes the rebate 10. The rim 9 leads to an upper surface 11 which in a preferred embodiment includes a concavity 12 (indicated in Fig. 2) in its central portion. This concavity can be used to provide a measure for a certain quantity of water. Spanning the concavity 12 is a handle 15. This handle may be strengthened by a connection between the handle and the bottom of concavity 12. An O-ring seal may be provided on the underside of the lid to provide a seal with the drum body of the mixer.

In use the drum is set upright on end 2, filled with the contents to be mixed, and the lid engaged with the drum. The mixer is then placed on its side on the ground, and rolled by hand (as in Fig. 6) or kicked by foot, preferably in alternating directions. The ribs 8 create a tumbling movement, whereby the contents of the drum are lifted, relocated along the length of the mixer, dropped and redistributed. Depending on the drum size, it has been found in tests that high quality concrete is obtained within 1-12 minutes. The mixing can take place on substantially any surface, whether it is rough or smooth. Once the mixing has been completed the drum is stood upright again and the lid 4 removed. The contents may then be emptied. As a result of the drum interior's smooth surfaces and few recesses, cleaning is particularly easy, and may be carried out by a simple hosing operation.

## Claims

1. A mixer comprising a drum (1) having a cylindrical wall (13), an open end (3), a closed end and at least one helical mixing rib (8), there being further provided a lid (4) for closing the open end (3) of the drum (1).
2. A mixer according to claim 1 adapted to be rolled manually on the ground.
3. A mixer according to claim 1 or 2, wherein said lid (4) and drum (1) have co-operating threads.
4. A mixer according to any preceding claim , wherein the lid (4) has a concavity (12) in its central portion, and a seal is provided between said lid (4) and said drum (1).
5. A mixer according to claim 4, wherein the seal is an O-ring.

DRAWINGS OF THE APPLICATION

FIG 1

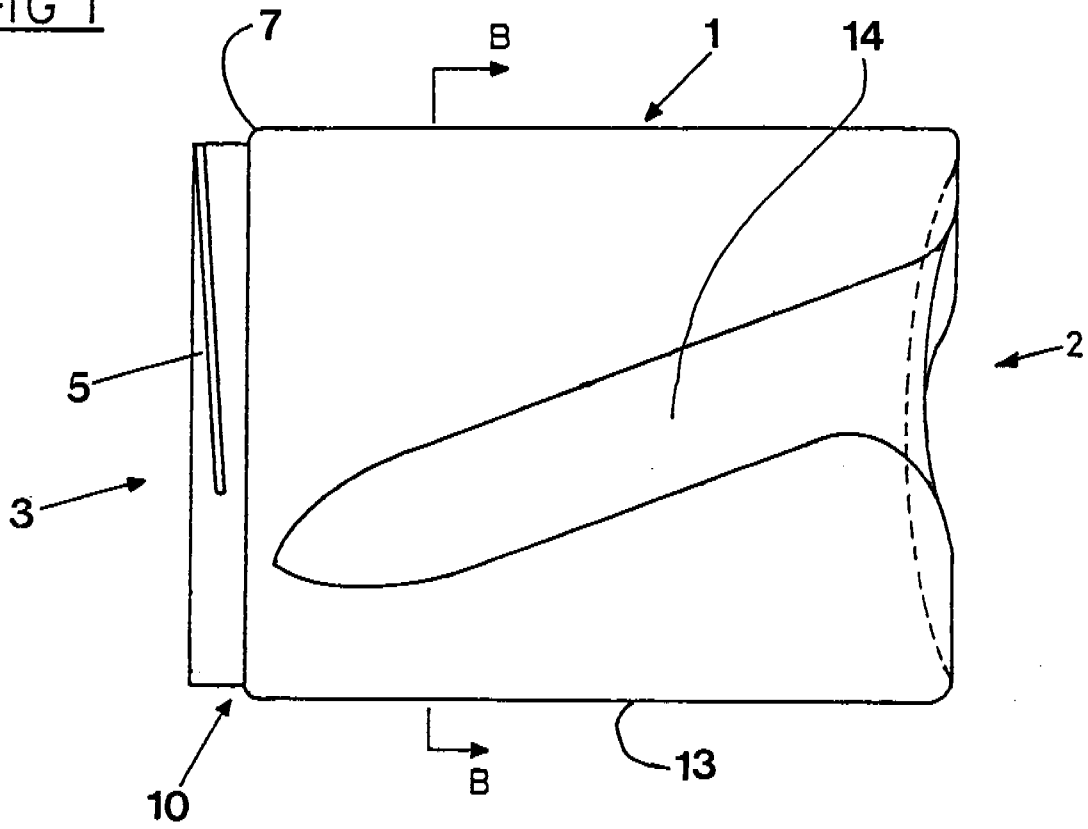
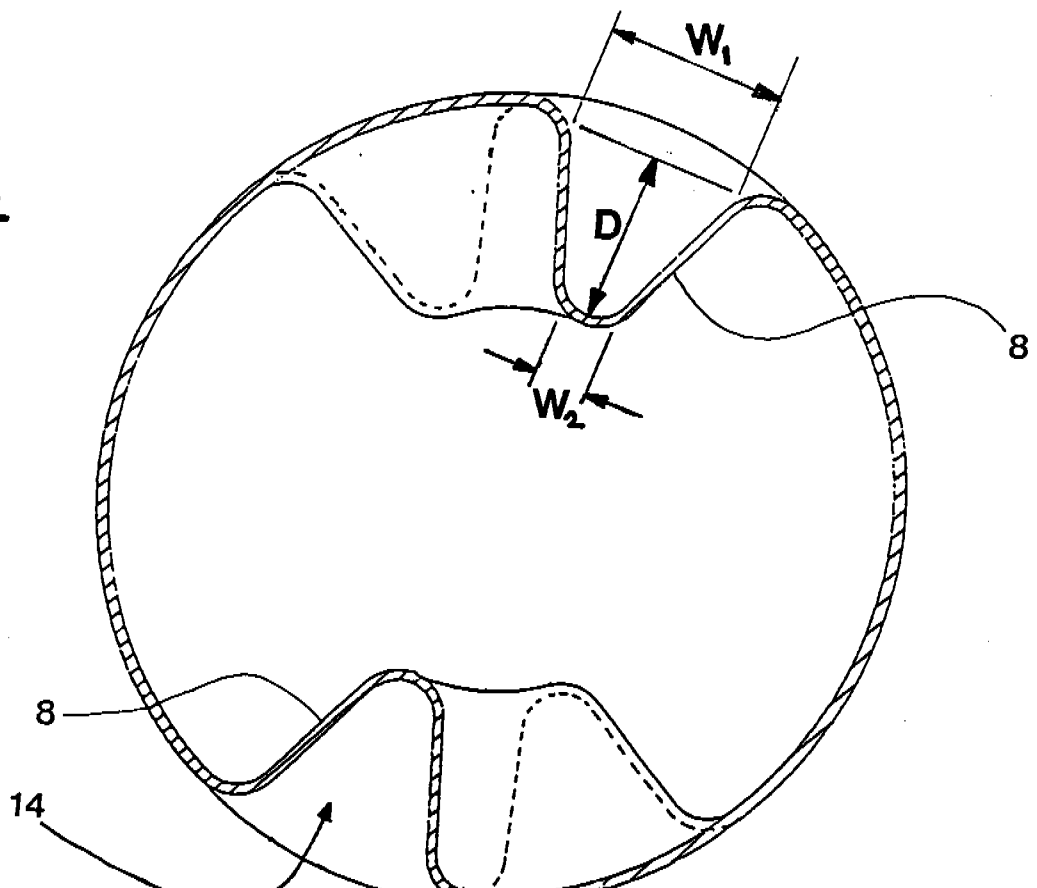

FIG 4



DRAWINGS OF THE APPLICATION

2/3

FIG 2

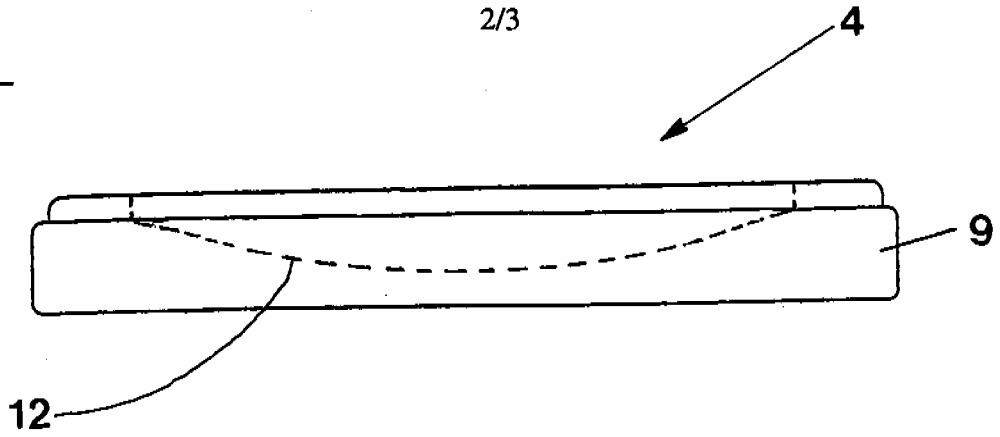
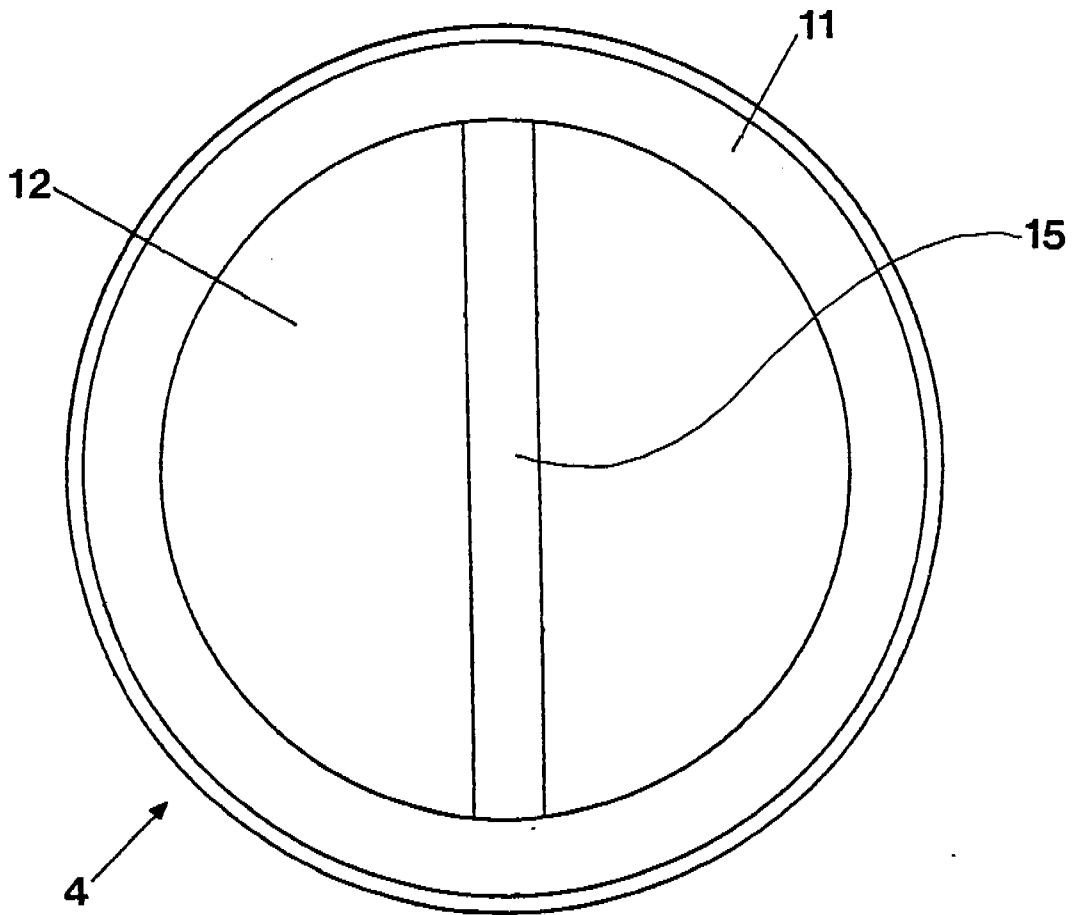

FIG 3





DRAWINGS OF THE APPLICATION

3/3

FIG 5

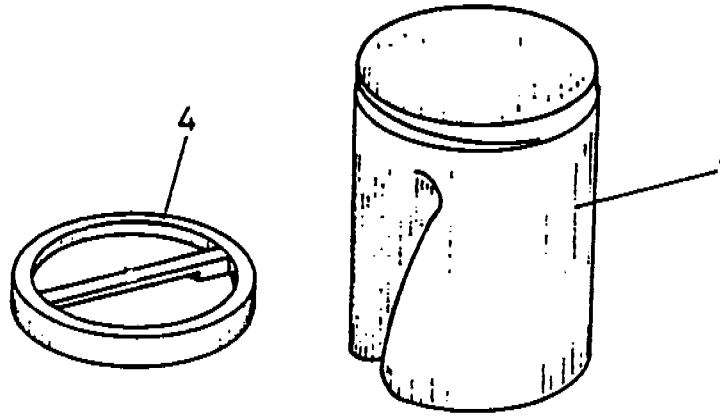
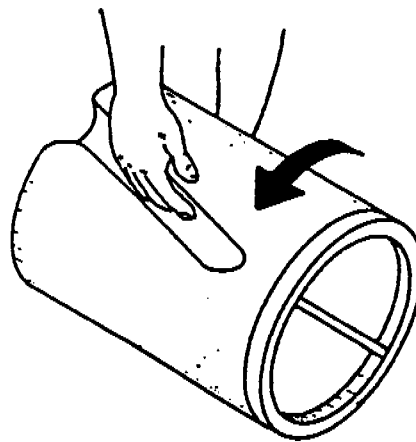

FIG 6



**COMMUNICATION UNDER ARTICLE 96(2) AND RULE 51(2) EPC**

The examination is being carried out on the application documents as originally filed

\*\*\*\*\*

1. The following pre-published documents are mentioned in this communication; the numbering used will be retained in the subsequent proceedings:

Document DI and

Document DII.

2. The present application does not meet the requirements of Articles 52(1), 54(1),(2), EPC, because the subject matter of claim 1 is not new.
3. From DII (to which the following reference signs refer) a mixer is known which comprises a drum (30) with a cylindrical wall, an open end (left side of drum of Fig. 1), a closed end (right side of drum of Fig. 1), at least one helical mixing rib (32), and a lid (15) for closing the open end of the drum.
4. Since the entire subject matter of claim 1 is already known from DII, this claim is not allowable.
5. Claim 2 does not meet the clarity requirement of Article 84 EPC as it does not specify technical features but only a result to be achieved. Furthermore the mixer of DII is clearly capable of (i.e. adapted to) being placed on the ground and rolled manually by use of handles (11). Claim 2 therefore lacks novelty. Motivation for using the mixer of DII in this way can be found in DI.
6. DII also discloses a twist-and-lock mechanism for fixing the lid (15) to the drum (30). Cooperating threads are an extremely common form of a twist and lock mechanism. Claim 3 is therefore unable to provide an inventive (Art. 56 EPC) basis for a newly drafted independent claim.

7. The lid (15) of DII is intended to "tightly close and seal" the open end of the drum (30). Incorporation of an O-ring seal into the lid constitutes an obvious way, to the skilled man, of achieving this. Furthermore, lid (15) has an external concave recess. Thus none of the features of claims 4 or 5 are able to form the basis for an inventive independent claim that would meet the requirements of Articles 52(1) and 56 EPC.
8. It is not at present apparent which part of the application could serve as a basis for a new, allowable claim. Should the applicant nevertheless regard some particular matter as patentable, an independent claim including such matter should be filed. The applicant should also indicate and justify in the letter of reply, on the one hand, the difference of the subject-matter of the new claim vis-à-vis the state of the art and, on the other hand, the inventive significance thereof.
9. Any newly submitted independent claim(s) should use the two-part form (Rule 29(1) EPC).

**DOCUMENT DI (State of the Art)**

The following article for aid workers in developing countries is taken from issue 127 (May 1996) of the monthly magazine of the "Eradicate Poverty Organisation" (EPO).

**Constructing a Simple Concrete Mixer For Use In Rural Areas**

In areas with no power supply for electric motors or fuel for internal combustion engines, concrete must be mixed manually. Usually the concrete is mixed in small batches on the ground or in a wheelbarrow, using a spade or shovel to mix the ingredients. Such mixing is slow, tiring, and results in batches of unequal quality. In this article we show you how to make a simple mixer which can be rolled on the ground by foot or by hand.

The starting point for the mixer is a cylindrical water or oil barrel. Wooden ribs are fixed to its inside surface. Metal or plastic barrels may be used. However, metal barrels are prone to corrosion, since any protective layer (e.g. galvanization) will eventually be abraded and removed during use. In view of this, the newer type of blow moulded, plastic barrel is preferable.

Any manageable size of barrel may be used, but it is recommended that the height does not exceed 75 cm and that the diameter is in the range 40-55 cm. This allows the cutting of an entry hole having a diameter of about 25 cm or greater, which has been found to be a convenient size both for filling and emptying the mix, and for gaining access to the interior of the barrel during fitting of the mixing ribs.

The mixer is made in 4 simple stages:

- 20 **Stage 1**: Cut a circular hole in the top of the barrel. The hole should have a diameter roughly 60% of the diameter of the top, thus leaving an adequate lip for retaining the mix in the barrel. The hole must also be concentric with the top of the barrel. Any other holes remaining in the barrel should be permanently sealed.

Stage 2: Prepare wooden ribs for fitting longitudinally (i.e. parallel to the axis of the barrel) on the interior wall of the barrel. The ribs fulfil both a mixing and reinforcing function, and should run the entire length of the barrel. Experience shows that there should be at least 4 ribs, equally spaced within the barrel, otherwise agglomeration of the mix occurs each time the barrel stops. The dimensions of the ribs may be adjusted to suit the locally available wood, but it is recommended that they have a minimum cross-section of 4 cm x 4 cm. The ribs should be slightly rounded on their upper surface.

Stage 3: Install the ribs. The ribs are secured on the inside of the barrel by any suitable wood screws penetrating from the outside, using a spacing of 10 cm between screws. Glue may be applied between the ribs and the barrel to strengthen the connection.

Stage 4: Now add additional reinforcing elements between the ribs. These elements help to support the longitudinal ribs as they carry the concrete mix upwards during rotation, and also reinforce the barrel. They are built up from thick strips cut from lorry tyres, or any similar resilient material that will conform to the curvature of the barrel. The strips are cut into appropriate lengths and fixed to the interior of the barrel in the same way as the ribs.

In use the barrel is filled with cement, sand and (optionally) aggregate through the top hole. It is then turned on to its side and rolled. The number of revolutions required must be established by trial and error, but the author has found that good results are generally obtained after about 100 fairly rapid revolutions. On completion of the mixing, the barrel is gradually tilted and finally lifted into the air, until all of the concrete has been emptied. After emptying, the mixer must be thoroughly washed. Particular care must be taken to remove all traces of concrete from the cavities between the ribs and the additional reinforcing elements, and from behind the lip at the top of the barrel.

**DRAWING OF DOCUMENT DI (State of the Art)**

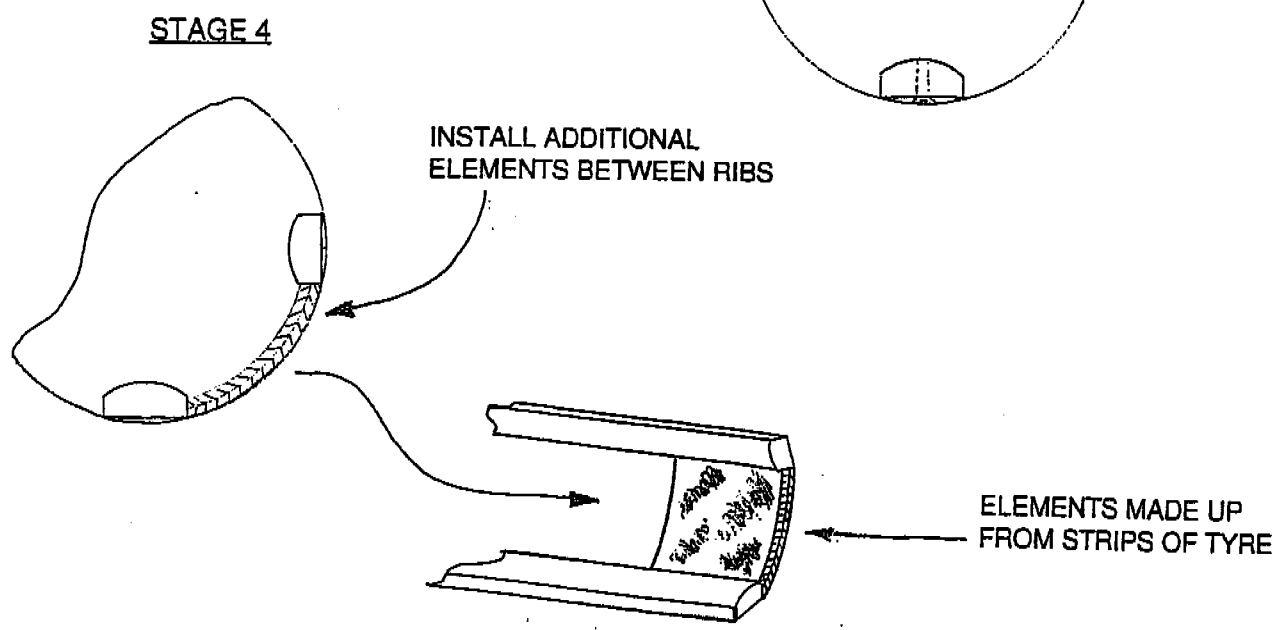
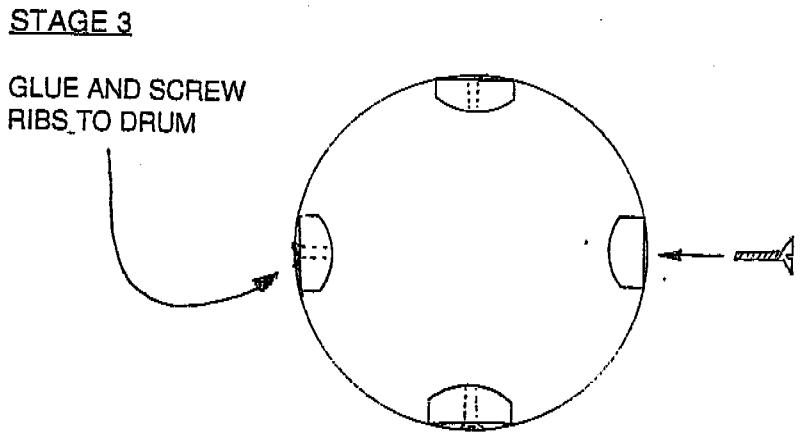
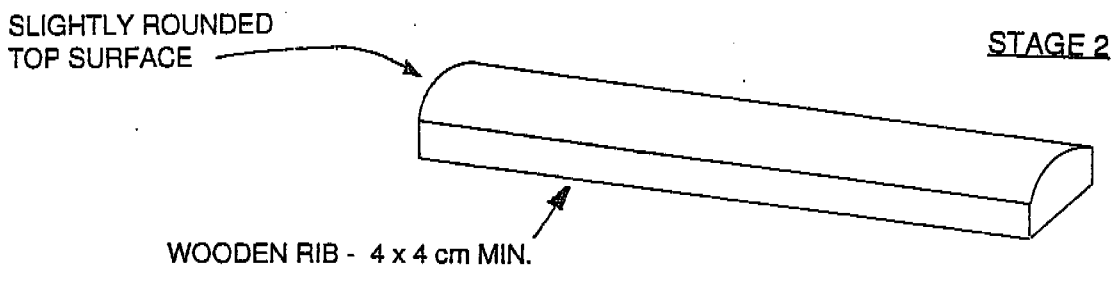
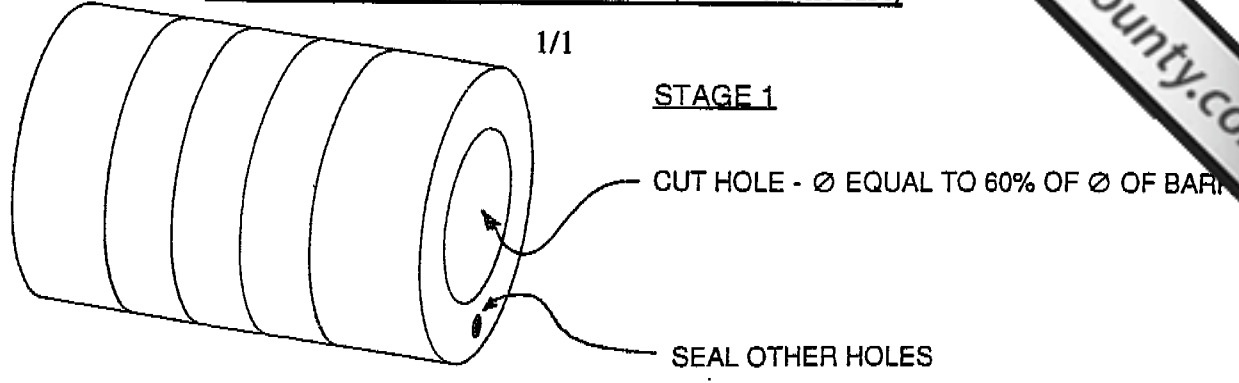

**DOCUMENT DII (State of the Art)**

The invention relates to an apparatus for mixing small quantities of paint.

Fig. 1 shows a side perspective of the mixing vessel and its drive arrangement.

5 Fig. 2 shows a front elevation, together with hidden detail, of the mixing vessel.

Fig. 3 shows a series of side elevations of the mixing vessel during mounting into its drive arrangement.

Paint mixing is often carried out discontinuously in small batches. After completion of each batch, the mixing vessel must be thoroughly cleaned before a new paint batch of different colour and type may be mixed. This process is time-consuming. The present invention overcomes this problem by providing a single drive arrangement to which numerous different mixing vessels may be exchangeably mounted. Mixing vessels may therefore be dedicated to a particular paint type and colour, and need not be so exhaustively cleaned as before.

Fig. 1 shows a frame 10 supporting a cylindrical drum carrier 12 which rotates in a bearing 14 about an axis inclined to the horizontal. The carrier is driven by motor 16 via belts 18. At two diametrically opposite points of the carrier 12 are a pair of inwardly projecting drive pins 26. The carrier supports a cylindrical mixing drum 30, the drum having a capacity of 2 litres and a diameter of approximately 11 cm. In the cylindrical wall of the drum 30 are two coarse-pitched, helical grooves. Each groove is 5 mm wide. As shown in Figs. 2 and 3, each groove 28 forms an internal rib 32 which projects into the drum 30. Helical ribs 32 serve to agitate and distribute the contents as the drum rotates. Each helical groove 28 opens through the plane of the base of the drum so that it can receive a drive pin 26  
25 when the drum is introduced into carrier 12.

The drum 30 has handles 11 for lifting the drum into and out of the carrier. It also has a lid 12 which is fixed on the drum 30 by use of a twist and lock mechanism so as to tightly close and seal the drum at one end. The lid is turned by use of a grip (not shown) set in an external concave recess.

- 5 In use the drum is kept in place by the drive pins 26 and the inclination of the axis of rotation of the carrier.



DRAWINGS OF DOCUMENT DII (State of the Art)

StudentBounty.com

FIG. 1.

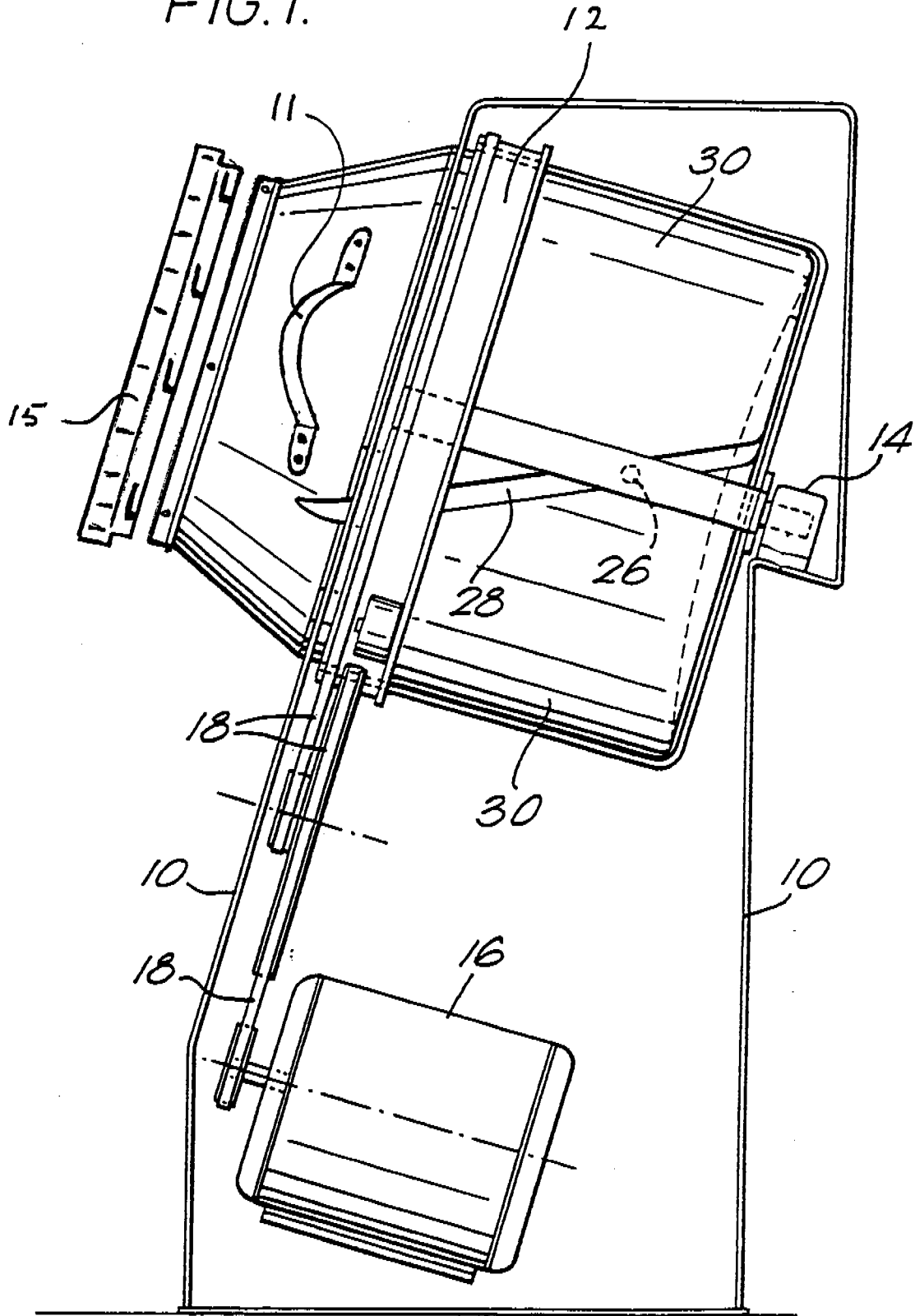

DRAWINGS OF DOCUMENT DII (State of the Art)

2/2

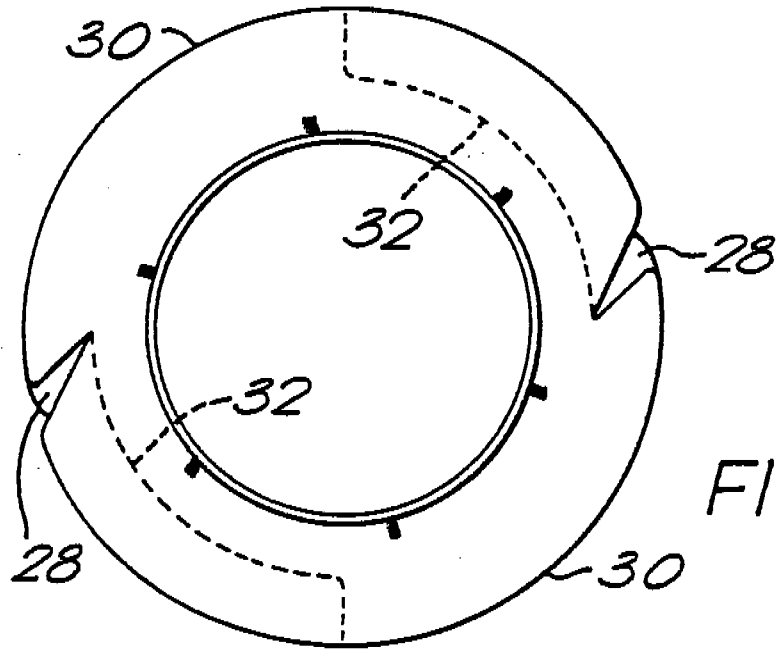

FIG. 2

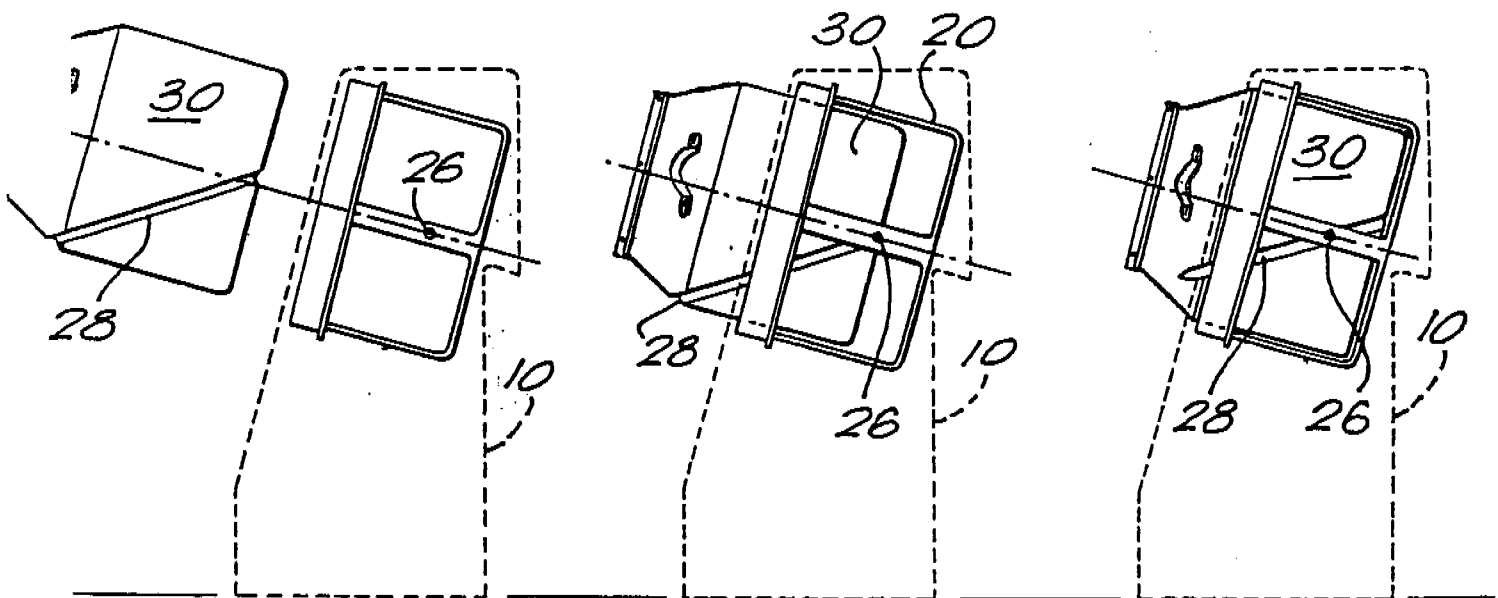

FIG. 3

CLIENT'S LETTER

# MAESTROMIX

Fax from: I. Wobblon, Maestromix Technical Developments

To: A. Turney; Smuggit, Turney and Partners

Dear Mr. Turney,

Thanks for your fax concerning the examiner's communication with respect to our application for the ground-rolled mixer. Please prepare a response to the communication from the examiner. However, in drawing up your reply, please try to cover, as far as possible, the further developments described below, taking care not to put our application at risk.

We are presently developing commercial models of the mixer, and have a number of different options under trial. One particularly interesting version is based on a frustro-conical (non-cylindrical) drum, which rolls approximately in a circle. A drum of this shape has the advantage that the user can roll it around in a circle, thus requiring less space. We are also working on improving the mixing effectiveness, and seem likely to adopt an arrangement of staggered linear mixing ribs/recesses, which are proving very effective at preventing agglomeration of the mix without compromising the hand rolling aspects. A simple sketch of a mixer incorporating both of these features is shown below:

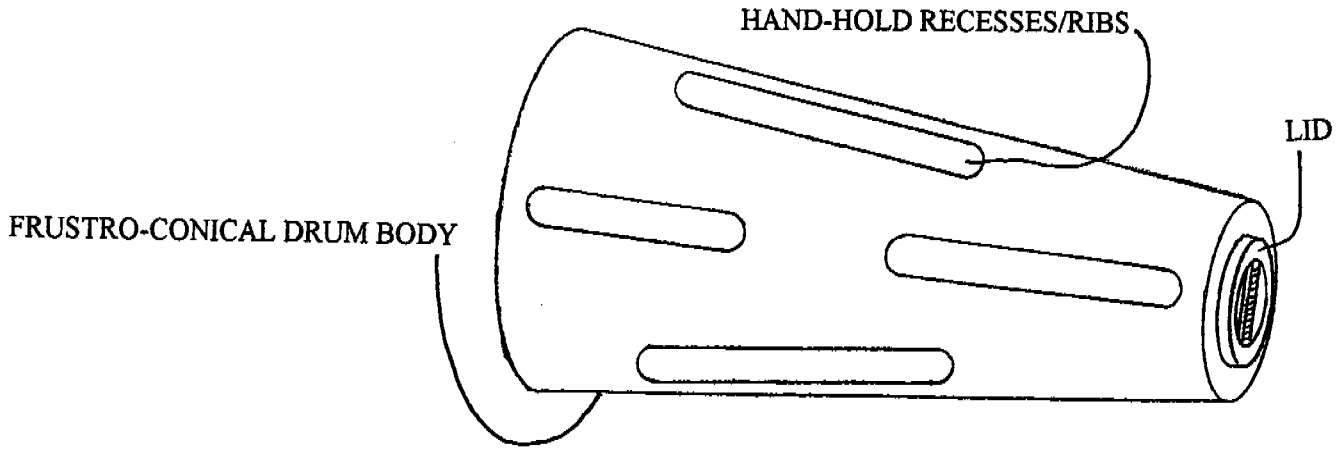

Best regards,

Ivor Wobblon