

EUROPEAN QUALIFYING EXAMINATION 1999

PAPER B ELECTRICITY / MECHANICS

THIS PAPER COMPRISES:

- | | |
|---|-------------------|
| * DESCRIPTION OF THE APPLICATION | 99/B(E/M)/E/1-4 |
| * CLAIMS | 99/B(E/M)/E/5 |
| * DRAWINGS OF THE APPLICATION | 99/B(E/M)/E/6-8 |
| * COMMUNICATION | 99/B(E/M)/E/9-10 |
| * DOCUMENT DI (STATE OF THE ART) | 99/B(E/M)/E/11 |
| * DRAWINGS OF DOCUMENT DI
(STATE OF THE ART) | 99/B(E/M)/E/12-13 |
| * DOCUMENT DII (STATE OF THE ART) | 99/B(E/M)/E/14 |
| * DRAWING OF DOCUMENT DII
(STATE OF THE ART) | 99/B(E/M)/E/15 |
| * DOCUMENT DIII (STATE OF THE ART) | 99/B(E/M)/E/16 |
| * DRAWINGS OF DOCUMENT DIII
(STATE OF THE ART) | 99/B(E/M)/E/17-18 |
| * CLIENT'S LETTER | 99/B(E/M)/E/19 |

DESCRIPTION OF THE APPLICATION

The invention relates to an amusement apparatus as defined in the preamble of claim 1.

Such an amusement apparatus is known from document DI. In this known apparatus the gondola remains horizontal at all times. The motion effects obtainable by such apparatus no longer fulfil the present day
5 expectations of passengers of such amusement apparatuses.

The object of the invention is to create an amusement apparatus with new motion effects.

This object is achieved by the characterising features of claim 1. Advantageous embodiments of the
10 amusement apparatus are described in the dependent claims.

As a result of the compensating means, the arms can be rotated not only in phase as known from DI, but also out of phase. When the arms are rotated in phase, the passenger gondola describes a path corresponding to the circumference of an imaginary circular cylinder, i.e. remaining always parallel to the
15 cylinder's longitudinal axis. When the arms are rotated out of phase, the passenger gondola is tilted with respect to the longitudinal axis of the cylinder, thereby producing novel motion effects.

Examples of embodiments of the invention are illustrated in the drawings.

20 Fig. 1 is a schematic front view of an embodiment of the amusement apparatus, in a first mode of operation,

Fig. 2 is a side view of the amusement apparatus according to Fig. 1,

25 Fig. 3 shows a second mode of operation of the apparatus of Fig. 1,

Fig. 4 shows a part of the passenger gondola of a further embodiment of the amusement apparatus.

The amusement apparatus of Fig. 1 comprises a pair of upright supports 4, 5 and a passenger gondola 17 suspended from the supports by means of two arms 10, 10a.

The supports 4, 5 are designed as foldable masts and are carried by chassis 1, 2 provided with wheels 3.

- 5 The chassis 1, 2 are set up in parallel alignment with a predetermined spacing between one another and are secured together by spacing elements 6, 7. In a set-up state, the supports 4, 5 are stabilised by struts 18, 19, as shown in Fig. 2 for support 4.

Each arm 10, 10a has an extension 13, 13a to the end of which a counterweight 14, 14a is attached.

10

The arms 10, 10a are rotatably mounted on the supports 4, 5 about respective horizontal axes 9, 9a and each end 16, 16a of the gondola 17 is freely rotatable by means of a bearing 26, 26a provided on the free end of the respective arm 10, 10a.

- 15 Each arm 10, 10a is driven about its respective rotational axis 9, 9a by means of an electric or hydraulic motor (not shown). The two motors are independent and can be controlled to rotate the arms 10, 10a in the same or opposite directions with the same or different speeds.

20 If both arms 10, 10a are rotated in the same direction and at the same speed, the gondola 17 generally moves along a path 20 corresponding to the circumference of a circular cylinder, (see Figs. 1 and 2), i.e. continuously remaining parallel to the cylinder's longitudinal axis which coincides with the rotational axes 9, 9a. The centre of gravity of the gondola 17 is well below the bearings 26, 26a to ensure that the gondola itself does not roll over, i.e. that it always hangs downwards during operation.

- 25 If the two arms 10, 10a are rotated independently of each other, the gondola 17 will no longer move along the cylindrical path 20, i.e. the gondola 17 does not remain parallel to the rotational axes 9, 9a (see Fig. 3). As a consequence, the geometry of the arrangement changes and it is necessary to compensate for these changes.

It is either necessary to:

- a) provide a mechanism to maintain the distance between the bearings 26, 26a substantially constant,
- 5 b) provide a mechanism which enables the effective length of the gondola 17 to be varied.

A compensating mechanism of the kind referred to in a) above is shown in Figs. 1 and 3 in the form of two pivotal joints 30, 30a, each provided between a support 4, 5 and its respective arm 10, 10a. The axis 11, 11a of each pivotal joint 30, 30a is perpendicular to both the longitudinal axis of the arm and the
10 rotational axis 9, 9a.

In this way, the arms 10, 10a may rotate in the same direction at different speeds. An instantaneous impression of such an operating state is shown in Fig. 3, where one end 16 of the gondola 17 is in a lower position and the other end 16a is in a higher position, so that the gondola 17 extends at an angle through
15 the imaginary cylinder. This, of course, can also be achieved by rotating the arms 10, 10a in opposite directions or by varying the rotational speeds of the two arms 10, 10a.

Shock-absorbing elements 12, 12a are provided to dampen the pivoting motion of the arms 10, 10a about the axes 11, 11a.

20

Fig. 4 shows a compensating mechanism of the kind referred to in b) above. This figure shows a part of a passenger gondola 17 which comprises two segments 17a, 17b. Segment 17a has supporting tubes 21, 22 disposed below its floor. Segment 17b has supporting beams 23, 24 disposed below its floor, the beams extending beyond the end wall 25 of segment 17b and being telescopically received in the supporting tubes
25 21, 22. Consequently, segments 17a and 17b can be moved toward and away from each other in the direction of the double arrow 31, so that the effective length of the gondola 17 may vary.

The amusement apparatus shown in Figs. 1 and 3 has a further compensating mechanism in addition to the above described compensation mechanism of the kind a). In this further compensating mechanism the
30 bearings 26, 26a are in the form of sliding bearings. Each sliding bearing is constituted by a shaft 27, 27a

carried by the arm 10, 10a and a sleeve 28, 28a mounted on the respective end 16, 16a of the shaft 27, 27a, the sleeve being slidably received on the shaft for movement in the direction of the double arrow 29, 29a. The shafts 27, 27a are connected with the arms 10, 10a by means of universal joints 15, 15a.

- 5 Although the amusement apparatus described with reference to Figs. 1 and 3 comprises two different kinds of compensating mechanisms it is to be understood that only one kind may be used. If only sliding bearings are to be used then the shafts 27, 27a have to be suitably longer to provide the required compensation.

- 10 It will also be understood that compensating mechanism does not have to be provided on both sides of the amusement apparatus.

CLAIMS

1. Amusement apparatus comprising at least two supports (4, 5), an arm (10, 10a) mounted on each support for rotation about a respective rotational axis (9, 9a), and a passenger gondola (17) connected with each arm (10, 10a) at a distance from the respective axis (9, 9a), characterised in that compensating means are provided which permit the arms (10, 10a) to be independently rotatable around the axes (9, 9a).
2. Amusement apparatus according to claim 1, in which a separate motor is provided for each arm (10, 10a).
3. Amusement apparatus according to claim 1 or 2, in which at least one arm (10, 10a) is pivotable about a pivot axis (11, 11a) perpendicular to the associated rotational axis (9, 9a).
4. Amusement device according to any preceding claim, in which at least one sliding bearing (26, 26a) is provided.
5. Amusement apparatus according to any preceding claim, in which the compensating means are provided on at least one end (16, 16a) of the passenger gondola (17).
6. Amusement apparatus according to any preceding claim, in which the passenger gondola (17) is telescopic.
7. Amusement apparatus according to claim 6, in which the passenger gondola (17) comprises segments (17a, 17b) which are slidable toward and away from each other.
8. Amusement apparatus according to any preceding claim, in which the passenger gondola (17) is rotatably mounted on the arms (10, 10a).

DRAWINGS OF THE APPLICATION

StudentBounty.com

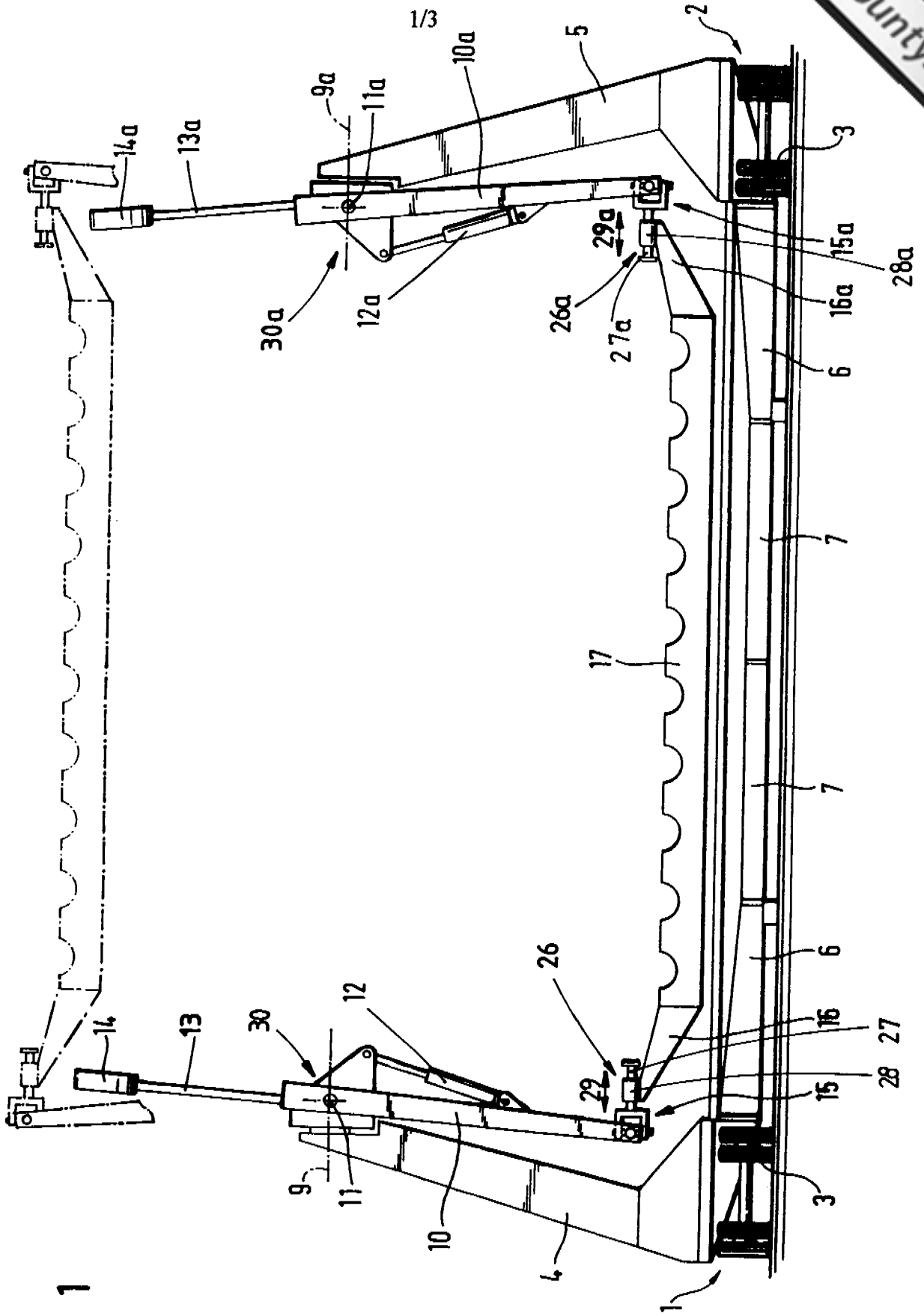

Fig. 1

2/3

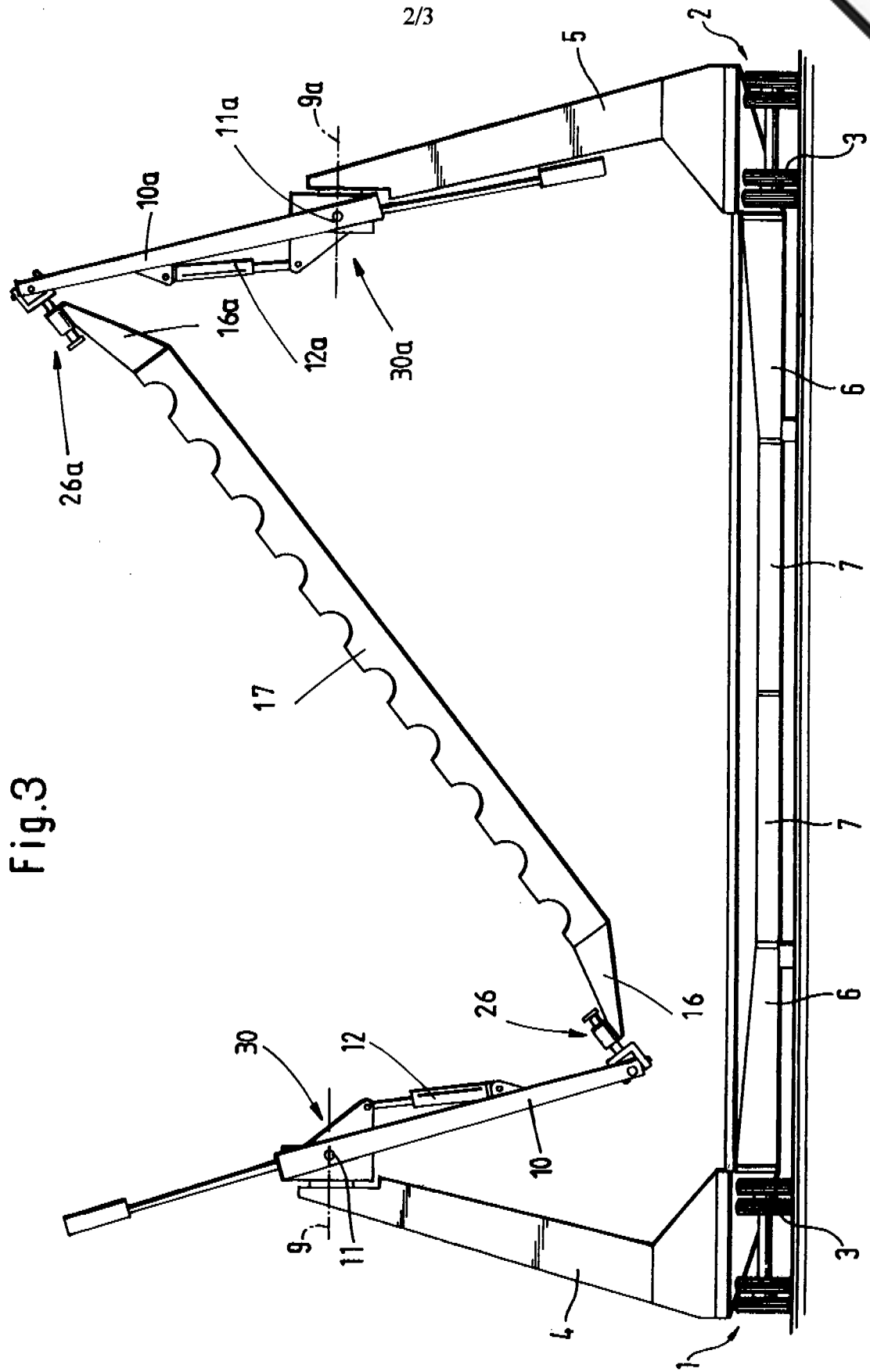

Fig.3

Fig. 2

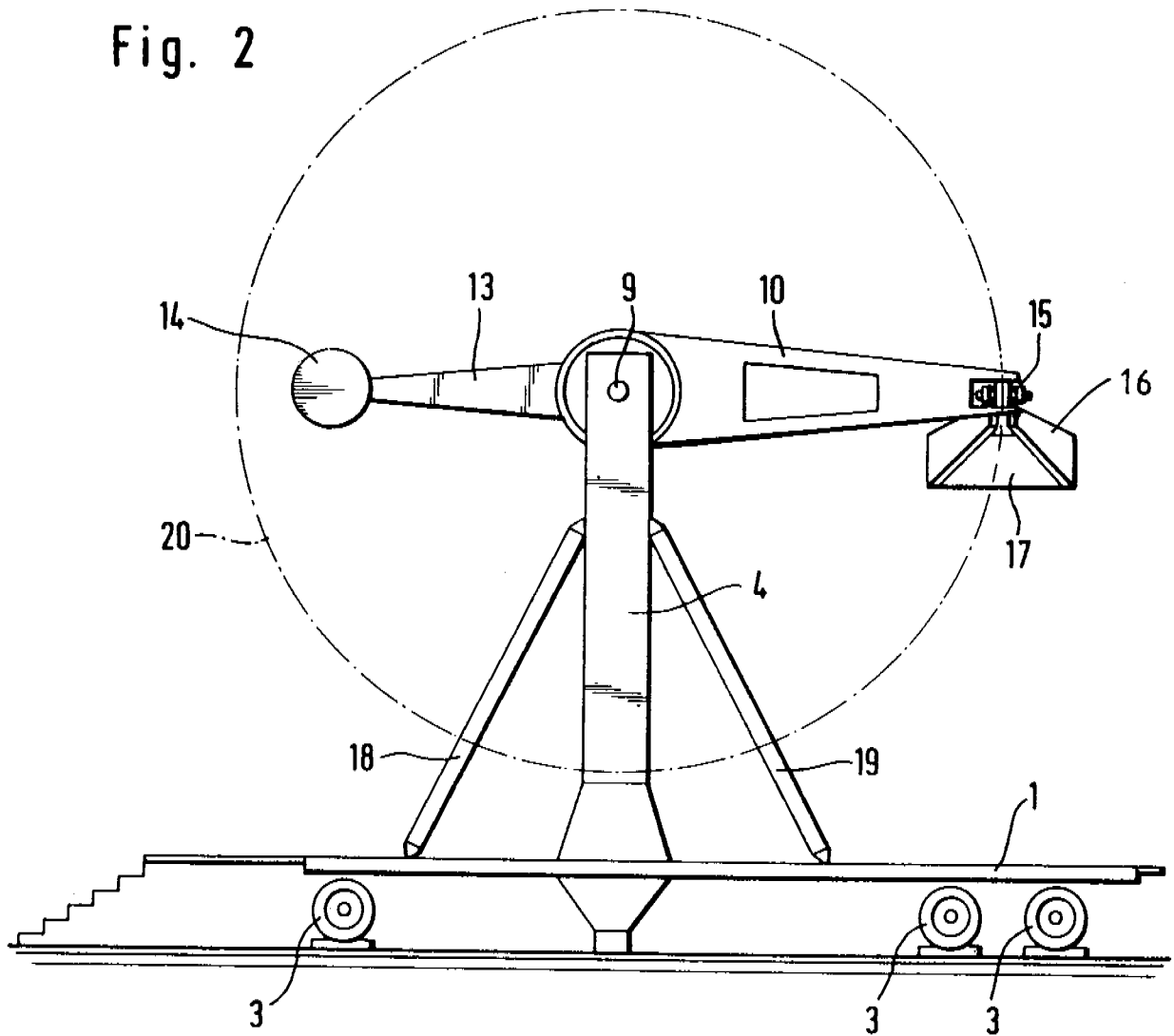
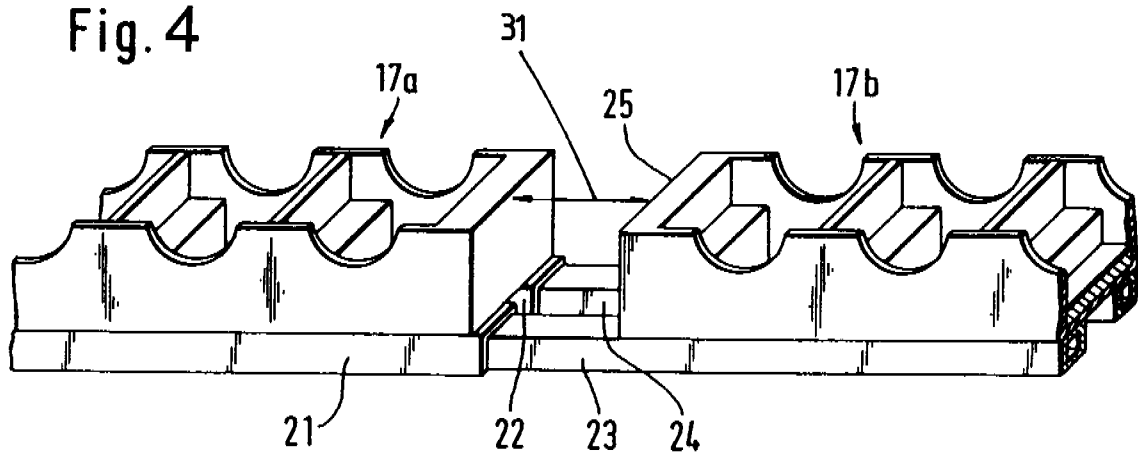

Fig. 4



COMMUNICATION UNDER ARTICLE 96(2) AND RULE 51(2) EPC

The examination is based on the application documents as filed.

1. The following pre-published documents are mentioned in this communication; the numbering used will be retained in the subsequent proceedings:

Document DI,
Document DII, and
Document DIII.

2. The present application does not meet the requirements of Articles 52(1) and 54(1), (2) EPC, because the subject-matter of claims 1 and 2 is not new.

- 2.1 From DII (to which the following reference signs refer) an amusement apparatus is known which has at least two supports 1, 2, an arm 3, 4 mounted on each support for rotation about a respective rotational axis 5, 6, a passenger gondola 11 connected with each arm 3, 4 at a distance from the respective axis 5, 6, and compensating means 14 which permit the arms to be independently rotatable around the axes 5, 6.

DII also discloses the provision of a separate motor 15, 16 for each arm 3, 4.

- 2.2 Since the subject-matter of claims 1 and 2 is already known in the prior art, these claims are not allowable.
3. Dependent claims 3-8 do not appear to contain any additional features which, in combination with the features of any claim on which they depend, could lead to subject-matter which is new and involves an inventive step.

3.1 The additional features of these claims are known from:

Claims 3, 5: DIII (see in particular last paragraph and Fig. 1: reference sign 16);

Claims 4, 5: DII (see reference sign 14 and paragraph 6);

Claims 6, 7: DII (see in particular paragraphs 2, 5 and the figure);

Claim 8: DI (see paragraphs 7 and 8), DII (see reference signs 9, 10), DIII (see reference signs 11, 11').

3.2 Should the applicant wish to use these features to limit the scope of the subject-matter of claim 1, it is pointed out that the resultant subject-matter would at least lack the required inventive step (Articles 52(1) and 56 EPC). The features mentioned in point 3.1 are disclosed in these documents in such a way that a person skilled in the relevant art would readily recognise their advantages. It would therefore be obvious to the skilled person to use these features in the amusement apparatus of DII.

4. It is not at present apparent which part of the application could serve as a basis for a new, allowable claim. Should the applicant nevertheless regard some particular matter as patentable an independent claim including such matter should be filed taking account of Rule 29(1) EPC. The applicant should also indicate and justify in the letter of reply, on the one hand, the difference of the subject-matter of the new claim vis-à-vis the state of the art and, on the other hand, the inventive significance thereof.

DOCUMENT DI (State of the Art)

The invention relates to an amusement apparatus.

The object of the invention is the further development of an amusement apparatus in such a way that it provides a more interesting ride.

5

Fig. 1 is a front view of the amusement apparatus according to the invention in a set-up state.

Fig. 2 is a side view of the amusement apparatus in various operating conditions.

10 The apparatus has an elongated base structure 1, provided with two upright supports 2.

Rotatably mounted at the top ends of the supports 2 are hubs 5 to which arms 6 are fixed. The two hubs 5 are connected by a main shaft 7 extending parallel to the longitudinal axis of the base structure 1. Each support 2 has an electric motor (not shown) for rotating the associated hub 5.

15

A passenger gondola 8 has a shaft 9 which is rotatably mounted at its ends on the arms 6. The arms 6 have extensions 12 which carry counterweights 13.

20 The passenger gondola 8 extends over nearly the whole length of the base structure 1 and is connected rigidly above its centre of gravity with the gondola shaft 9. The latter passes through a roof 15 of the passenger gondola 8.

In operation, the passenger gondola 8 is set in a swinging motion around the rotational axis of the main shaft 7 by the electric motors. After a certain number of swinging movements, the passenger gondola
25 performs complete rotations around this rotational axis. The passenger gondola 8 can also be halted at the point furthest from the ground by operating the electric motors accordingly.

DRAWINGS OF DOCUMENT DI (State of the Art)

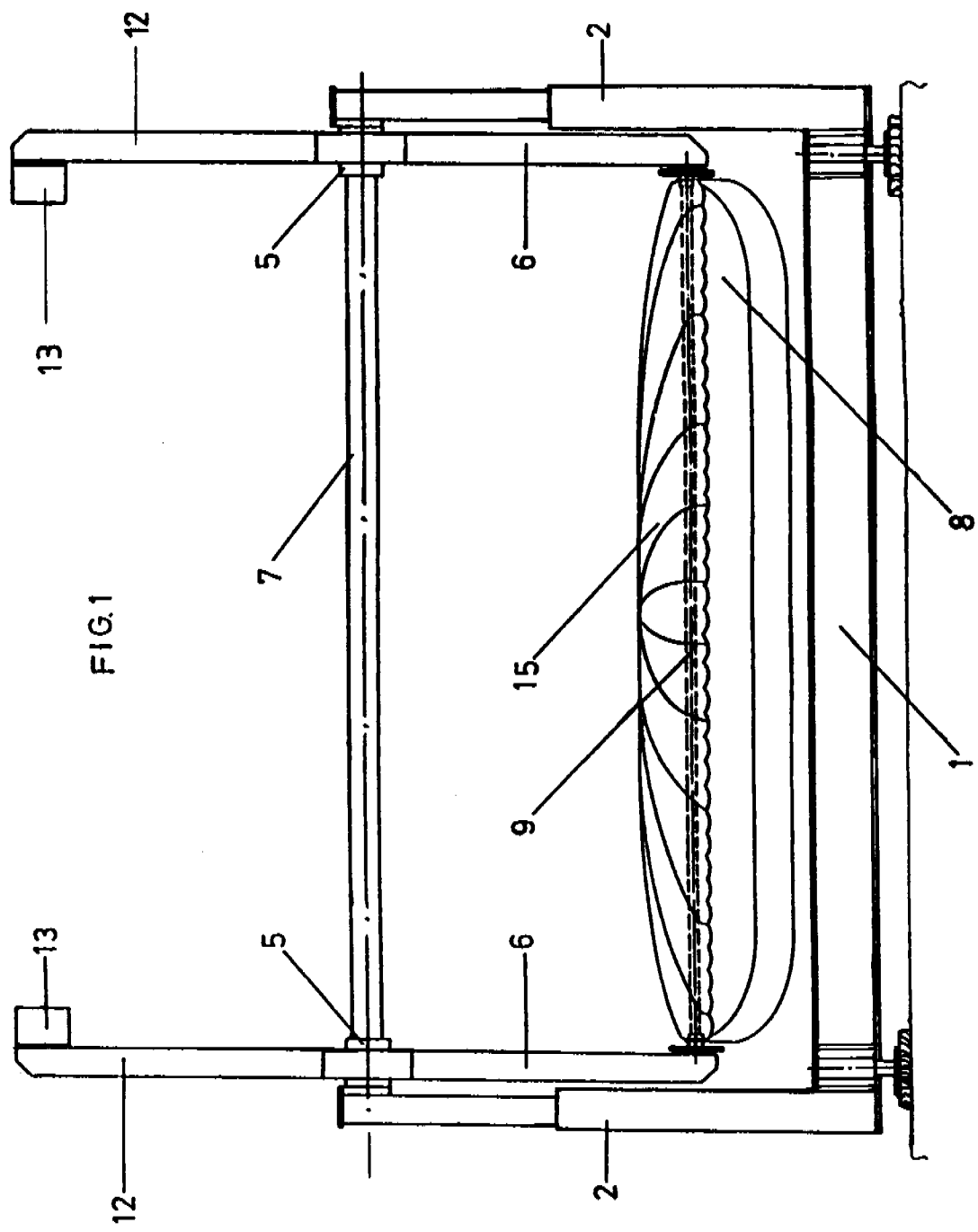

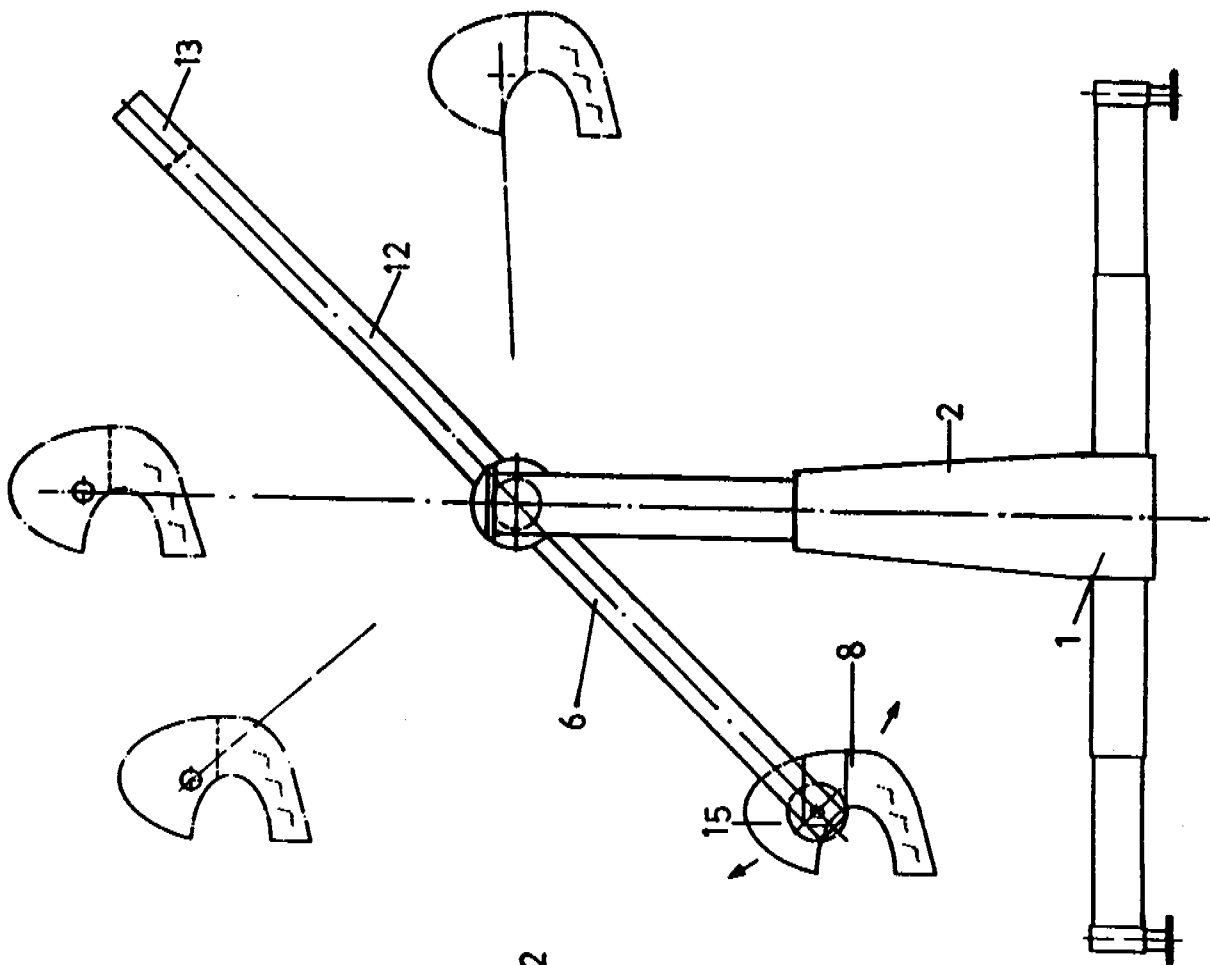

FIG. 2

DOCUMENT DII (State of the Art)

The apparatus shown in the drawing comprises two support pillars 1, 2. Two carrier arms 3, 4 are mounted for rotation on the support pillars by means of shafts 5, 6. Each arm 3, 4 is provided at one end with a counterweight 7, 8. The other end of each arm 3, 4 is connected to one end of a gondola 11 by means of a universal joint 9, 10.

5

The gondola 11 comprises two segments 12, 13 connected by a sliding mechanism 14. This enables the two parts of the gondola to slide towards and away from each other.

10 The shafts 5, 6 of the arms 3, 4 are driven by electric motors 15, 16 which can be operated independently of each other.

When the two motors 15, 16 are driven in a synchronised manner the two carrier arms 3, 4 can rotate in phase, i.e. the gondola 11 suspended between the carrier arms 3, 4 will then proceed to swing or rotate with the gondola remaining horizontal.

15

20 However, when the two motors 15, 16 are not driven in a synchronised manner, the carrier arms 3, 4 will be out of phase with one another. The sliding mechanism 14 compensates in this case for the variations in the distance between the universal joints 9, 10 which occur during operation. Depending on the control of the two motors 15, 16, the gondola is capable of performing spectacular movements in a cylindrical, three-dimensional space.

It is also possible to provide the sliding mechanism 14 at one or both ends of the gondola, so that the compensation of variations in distance takes place between the arm or arms 3, 4 and the gondola 11, instead of between the two segments 12, 13 of the gondola.

25

A specific situation, where the carrier arms 3,4 are 180° out of phase is shown in the drawing. The gondola 11 is then inclined to the horizontal.

DRAWING OF DOCUMENT DII (State of the Art)

1/1

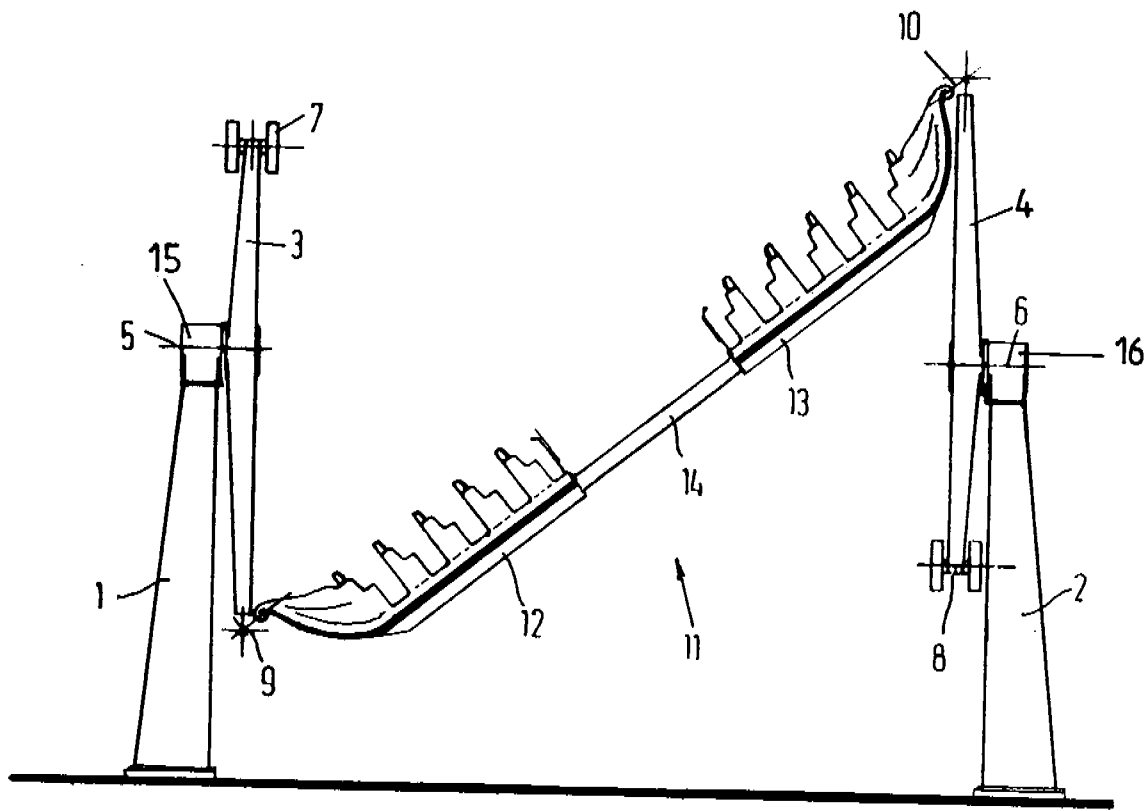

Fig. 1

DOCUMENT DIII (State of the Art)

This invention relates to an improvement of an amusement apparatus of the kind disclosed in DI.

In such apparatus the arms, supports and gondola must be exactly positioned relative to one another so as to prevent any stressing, or indeed jamming, of the arm hubs in the supports and/or the gondola shaft bearings in the arms. However, when the apparatus is being set up, for example at mobile funfairs, there is often a need for haste, which can lead to imprecise positioning of the parts. In the worst case, incorrect positioning of these parts can result in failure of the entire apparatus.

The object of the invention is to overcome the above disadvantages.

10

Fig. 1 and 2 illustrate an embodiment of the invention. Fig. 2 represents a cross-section along II-II of Fig. 1.

Fastened to a base structure 1 are two vertical supports 2, 2'. A pair of arms 5, 5' are rotatably mounted at the upper ends of the supports 2, 2' by means of hubs 4, 4'. The hubs and therefore the arms can be rotated in either direction and with a regulated speed by means of electric motors 6, 6'. The two hubs 4, 4' are connected with one another by means of a shaft 7 so as to ensure synchronised rotation of the arms.

The arms 5, 5' have extensions 8, 8' to which counterweights 9, 9' are attached.

20

The passenger gondola 10 is freely rotatably mounted in bearings 11, 11' at the ends of the arms 5, 5'.

In accordance with the invention at least one of the arms 5 is formed in two parts 5a, 5b connected together by means of a pivotal joint 16 for pivotal movement about an axis 15 perpendicular to the rotational axis and the longitudinal axis of the arm. In this way the stresses caused by improper positioning are prevented from arising. The location of the pivotal joint 16 on the arm 5 is to be so chosen as to completely compensate for any incorrect positioning that might occur. Therefore, the pivotal joint 16 could be located on the arm 5 closer to the shaft 7 than is shown in the figure.

DRAWINGS OF DOCUMENT DIII (State of the Art)

Fig. 1

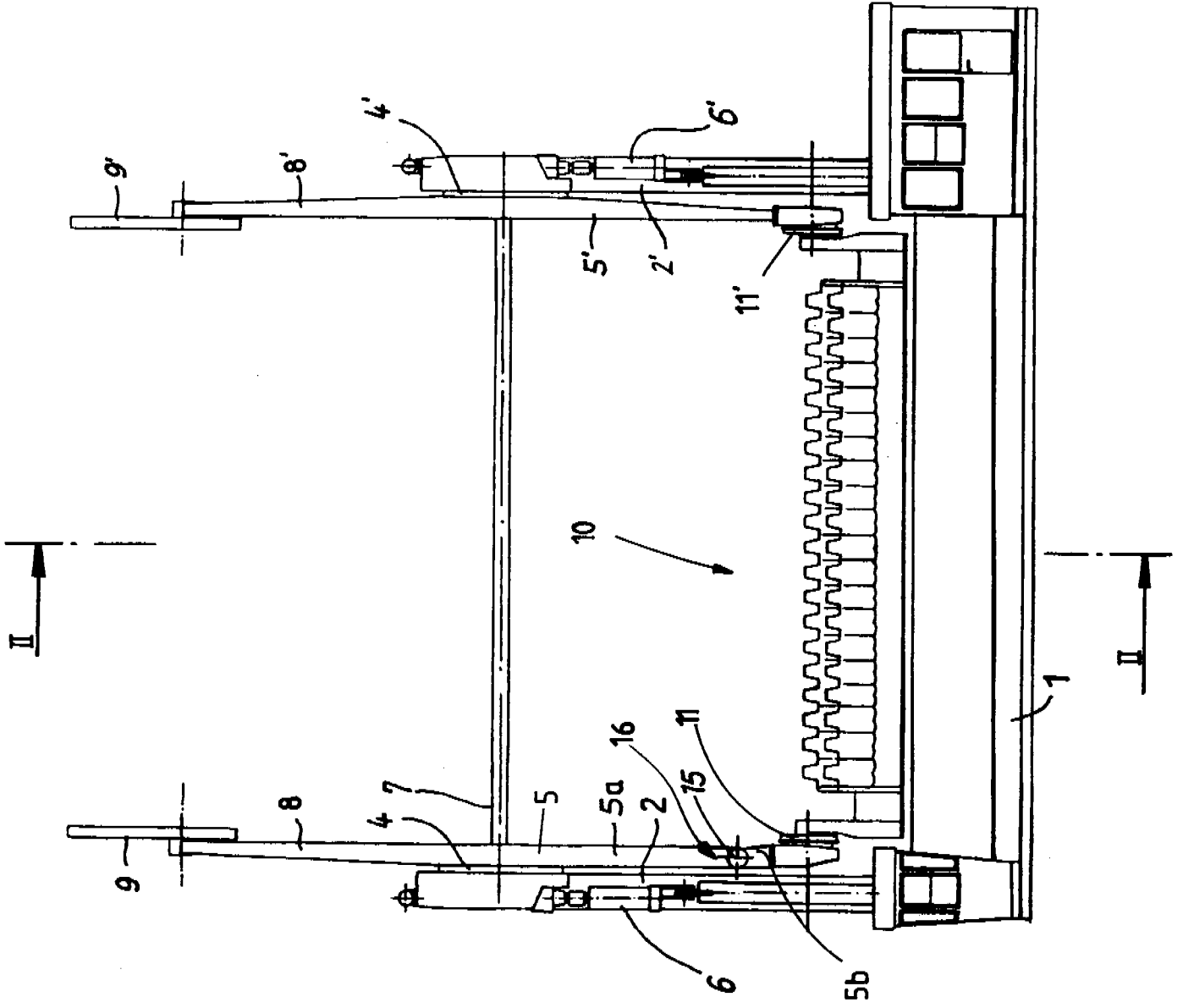

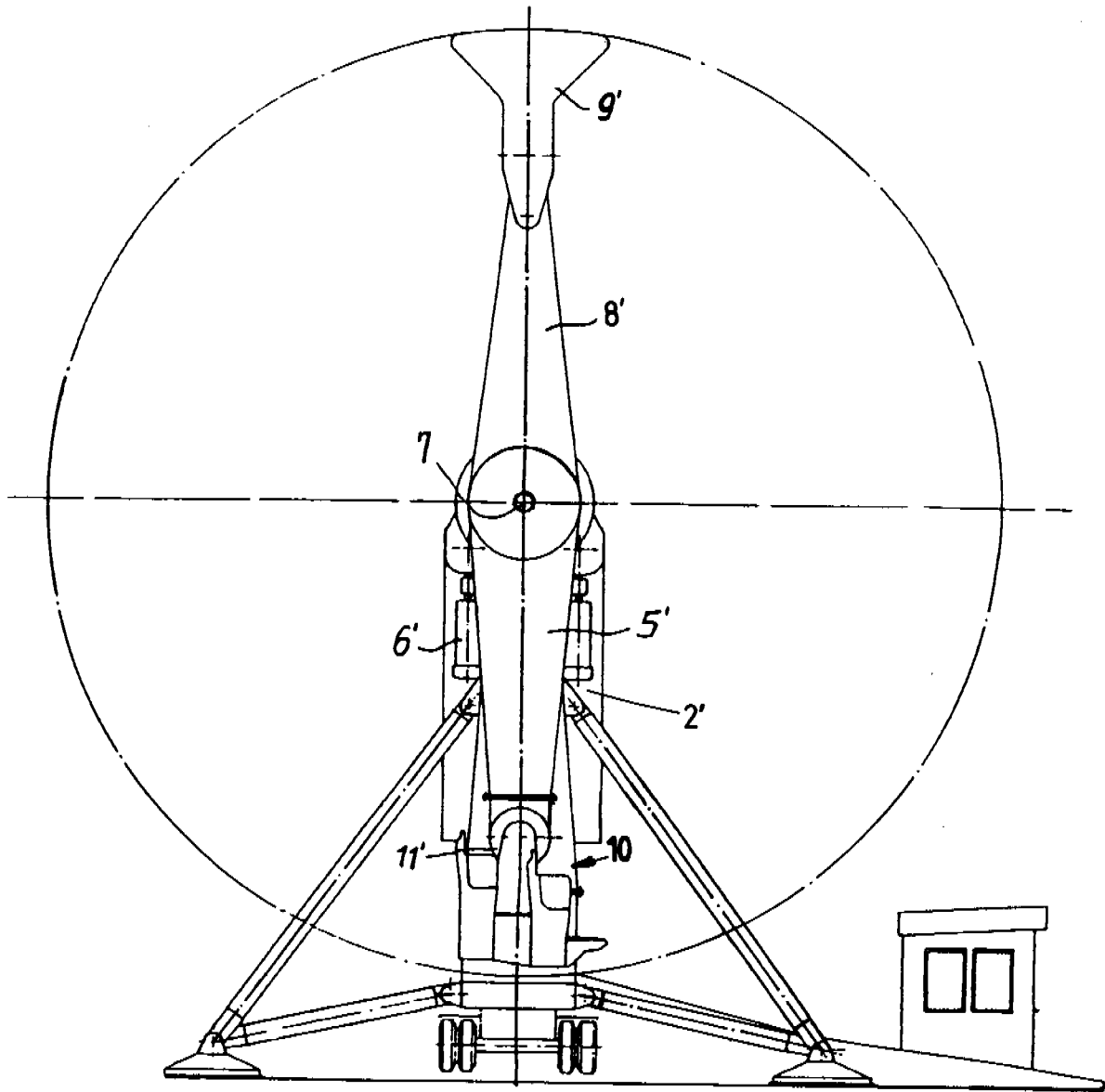

Fig. 2

CLIENT'S LETTER

Thank you for your letter, and the copies of the communication from the European Patent Office and the documents DI, DII and DIII.

In view of these prior art documents, we accept that it is necessary to restrict the scope of protection, but we would ask you to limit the subject-matter only in as much as is absolutely necessary.

Schlaumeier & Co.