

EUROPEAN QUALIFYING EXAMINATION 1997

PAPER B ELECTRICITY/MECHANICS

This paper comprises:

- | | |
|--|-------------------|
| * Instructions to Candidates | 97/B(E/M)/e/1 |
| * Description of the Application | 97/B(E/M)/e/2-6 |
| * Claims | 97/B(E/M)/e/7 |
| * Drawings of the Application | 97/B(E/M)/e/8-10 |
| * Communication | 97/B(E/M)/e/11-12 |
| * Document I (State of the Art) | 97/B(E/M)/e/13-14 |
| * Drawing of Document I (State of the Art) | 97/B(E/M)/e/15 |
| * Document II (State of the Art) | 97/B(E/M)/e/16 |
| * Drawing of Document II (State of the Art) | 97/B(E/M)/e/17 |
| * Document III (State of the Art) | 97/B(E/M)/e/18-19 |
| * Drawing of Document III (State of the Art) | 97/B(E/M)/e/20 |
| * Client's Letter | 97/B(E/M)/e/21 |

INSTRUCTIONS TO CANDIDATES

In this paper, you should assume that a European patent application for all the Contracting States comprising the appended documents(*) has been filed and that the European Patent Office has issued the annexed official communication. The paper may include a client's letter containing instructions about the way your client wishes to prosecute the European patent application.

You should accept the facts given in the paper and base your answers upon such facts. Whether and to what extent these facts are used is your responsibility.

You should not use any special knowledge you may have of the subject-matter of the invention, but are to assume that the prior art given is in fact exhaustive.

Your task is now to draft a full response to the official communication. The response should be a letter to the EPO, accompanied, if appropriate, by an amended set of claims. No amendments to the description should, however, be made.

The claims should afford the broadest protection possible while meeting the requirements of the Convention. In your letter of response you should set out your arguments in support of the patentability of the independent claim(s).

If you consider that any part of the application ought to be made the subject of one or more divisional applications, you should in a note, clearly identify the subject-matter of the independent claim of such divisional application(s), for example, by referring to selected portions of your claims. However, it is not necessary to draft the wording of the independent claim for the or each divisional application.

In addition to your chosen solution, you may - but this is not mandatory - give, in a note, the reasons for your choice of solution, for example, why you selected a particular form of claim, a particular feature for an independent claim, a particular piece of prior art as starting point or why you rejected or preferred some piece of prior art. Any such note should however be brief.

It is assumed that you have studied the examination paper in the language in which you have given your answer. If this is not so, please indicate on the front page of your answer in which language you have studied the examination paper. This always applies to candidates who - after having filed such a request when enrolling for the examination - give their answer in a language other than German, English or French.

(*) These documents do not necessarily constitute the only or best solution to the task set in Paper A.

DESCRIPTION OF THE APPLICATION

The present invention relates to a dry shaver comprising a motor having a rotor, a reciprocating cutter and a drive mechanism connecting the rotor to the reciprocating cutter and converting rotary motion to reciprocating motion.

- 5 The cutter has a plurality of cutter blades which reciprocate immediately behind a shear foil having openings therethrough, through which hairs to be shaved off extend so as to be cut by the cutter blades.

Single phase synchronous motors are widely used in such domestic appliances owing to their low cost and practically frictionless operation, owing to the absence of brushes in contact with the rotor of the motor. These motors rotate at a constant speed which corresponds to the ac mains frequency. In order to achieve a satisfactory cutting action with the above defined dry shaver, it is necessary that the reciprocating cutter has a sufficiently high speed of movement with respect to the openings in the shear foil. In view of the size of the appliance, a high movement speed of the reciprocating cutter can only be obtained by means of high frequency movement of the cutter. The speed of rotation of single phase synchronous motors is too low to achieve the necessary cutting action with high frequency movement of the cutter when the rotation of the motor is directly converted into a reciprocating movement by means of a simple crank. Higher speed motors are too bulky and expensive for use in such appliances and it is therefore necessary to ensure that the frequency of movement of the cutter is higher than the frequency of rotation of the single phase synchronous motor.

Document I discloses a dry shaver according to the preamble of claim 1. The drive mechanism comprises a first gear wheel, which is driven by the rotor and which meshes with a second rotatably mounted gear wheel. A first lever is pivotably connected to the second gear wheel by means of a pin eccentrically mounted on the second gear wheel. A second lever is connected to the first lever by means of a hinge and is pivotably mounted to the housing of the appliance. The free end of the second lever is connected to a reciprocating cutter element which is mounted in such a manner as to be able to reciprocate between two extreme positions. This appliance suffers from the problem

that it is noisy, owing to the meshing gear wheels which are required to achieve the necessary
of movement of the cutter.

According to the invention, this problem is overcome in that the drive mechanism comprises a cam
5 having a cam surface coupled to the rotor and a cam follower cooperating with the cam surface and
coupled to the reciprocating cutter. In this way, the frequency multiplying function of the drive
mechanism is achieved without the use of meshing gear wheels which are inevitably noisy.

Preferred features of the invention are the subject of dependent claims.

10

In the accompanying drawings:-

Fig. 1 is a plan view of a first embodiment of the drive mechanism of a dry shaver in accordance with
the invention;

15

Fig. 2 is a plan view of a second embodiment of the drive mechanism of a dry shaver in accordance
with the invention;

20

Figs. 2a and 2b show a cam and part of a cam follower forming part of the embodiment of Fig. 2 in
different positions; and

Figs. 3 and 4 show alternative embodiments of the cam of the drive mechanism of Fig. 2.

25

Fig. 1 shows the drive mechanism mounted on a wall 1 forming part of the housing of the shaver.
The remainder of the housing is not shown for the sake of clarity. The drive mechanism is driven by a
synchronous motor 2 which comprises a permanent magnet rotor 3 rotatably mounted in an air gap 4
between two pole pieces 5. An exciter coil 6 is mounted on each pole piece and the pole pieces are
connected by a stator iron 7.

30

A drive shaft 8 projects from the rotor 3 out of the plane of the drawing. The drive shaft 8 carries a
substantially elliptical cam 9 having a circumferential cam surface 10. A cam follower 11 is pivotably
mounted about a pivot 16 and comprises a lever having first and second arms 14 and 15 rigidly

connected to each other, and a wheel 12 which is journaled in a bearing 13 on the first arm 11. In virtue of the shape of the elliptical cam, that is, a cam having two lobes, the cam follower makes two excursions with each rotation of the cam. The cam follower thus oscillates at twice the frequency of rotation of the rotor 3.

5

The wheel 12 is provided with an elastic ring or tyre 26 and is biased into contact with the cam surface 10 by means of a compression spring 17. Optionally, the elastic ring or tyre may be omitted. The initial force of the spring 17 is adjustable by means of a set screw 18. This enables the desired biasing force to be set in the factory prior to shipping of the completed appliance. The desired force will depend on the frequency of the ac mains supply in the country in which the appliance is to be used, a higher frequency and thus a higher rotational speed of the motor necessitating a higher spring force in order to retain the cam follower 11 in contact with the cam 9.

15 The axis 19 of the spring 17 extends essentially through the axes of the wheel 12 and the rotor 3 and perpendicularly to the line 20 connecting the pivot 16 and the bearing 13.

The free end of the second arm 15 is provided with a driving member 21 which engages with a gripping member 22 of a cutter 23. Guide means 24 restrain the cutter 23 to reciprocating movement in the direction indicated by arrow 25.

20

Thus, as the cam 9 is rotated by the motor 2, the cam follower 11 undergoes a reciprocating movement which is transmitted to the cutter which reciprocates in the direction indicated by the arrow 25 at twice the frequency of rotation of the rotor.

25 Reference is now made to Fig. 2. The features of the embodiment of Fig. 2 which are identical to the corresponding features of the embodiment of Fig. 1 are allocated the same reference numerals and will not be further described in detail. In the embodiment of Fig. 2 it is not necessary to exert force on a wheel by means of a spring in order to maintain it in contact with the cam surface.

30 The cam follower 41 differs from that of the embodiment of Fig. 1 in that it has first, second and third arms 42, 43 and 44 rigidly connected to each other, first and third arms 42 and 44 each having a wheel 45 and 46 rotatably mounted thereon. Each wheel is provided with an elastic ring or tyre 26 in contact with the cam surface 10. As illustrated in Figs. 2a and 2b, both wheels remain constantly in

contact with the cam surface 10. Figure 2 illustrates the centre position of the cam follower which the wheels 45,46 are symmetrically disposed on each side of the long axis of the cam. Fig. 2a shows the wheel 46 in contact with the portion of the cam having the greatest diameter and the wheel 45 in contact with the portion of the cam having the smallest diameter. In this position, the cam follower drives the cutter 23 to its extreme leftmost position as indicated by the orientation of the second arm 43. Fig. 2b shows the wheel 45 in contact with the portion of the cam having the greatest diameter and the wheel 46 in contact with the portion of the cam having the smallest diameter. In this position, the cam follower drives the cutter 23 to its extreme rightmost position as indicated by the orientation of the second arm 43. The geometry of the mechanism is such that each wheel in each position of the cam prevents the other wheel from losing contact with the cam surface.

As an alternative to the provision of elastic rings or tyres 26, one or both of the first and third arms 42,44 may be elastic. As a further alternative, the bearings of one or both of the wheels may be elastically mounted on the respective arm.

15

In the embodiment of Fig. 3, the elliptical cam of Figs. 1 and 2 is replaced by a substantially triangular cam 59 having a cam surface 60, that is, a cam having three lobes. The use of such a cam means that the cutter reciprocates in the direction of the arrow 25 at three times the frequency of rotation of the rotor. As in the case of the elliptical cam, the geometry of the mechanism is such that each wheel in each position of the cam prevents the other wheel from losing contact with the cam surface.

20

In the embodiment of Fig. 4, a substantially square cam 69 having a cam surface 70 is used, that is, a cam having four lobes. Thus, the cutter reciprocates at four times the frequency of rotation of the rotor. As in the case of the other cams, the geometry of the mechanism is such that each wheel in each position of the cam prevents the other wheel from losing contact with the cam surface.

25

It is thus possible to attain various frequency multiplications merely by the selection of the appropriate cam.

List of reference numerals used

- 1 wall
- 2 motor
- 3 rotor
- 4 air gap
- 5 pole pieces
- 6 exciter coils
- 7 stator iron
- 8 drive shaft
- 9 elliptical cam
- 10 elliptical cam surface
- 11 cam follower
- 12 wheel
- 13 bearing
- 14 first arm
- 15 second arm
- 16 pivot
- 17 compression spring
- 18 set screw
- 19 spring axis
- 20 centre line of arm
- 21 driving member
- 22 gripping member
- 23 cutter
- 24 guide means
- 25 arrow
- 26 elastic ring or tyre

- 41 cam follower
- 42 first arm
- 43 second arm
- 44 third arm
- 45 first wheel
- 46 second wheel

- 59 substantially triangular cam
- 60 substantially triangular cam surface

- 69 substantially square cam
- 70 substantially square cam surface

CLAIMS

1. A dry shaver comprising a motor (2) having a rotor (3), a reciprocating cutter (23) and a drive mechanism connecting the rotor to the reciprocating cutter and converting rotary motion to reciprocating motion, characterised in that the drive mechanism comprises a cam (9; 59; 69) having a cam surface (10; 60; 70) coupled to the rotor and a cam follower (11; 41) cooperating with the cam surface and coupled to the reciprocating cutter.
2. A dry shaver as claimed in claim 1, wherein the motor is a single phase synchronous electric motor.
3. A dry shaver as claimed in either of claims 1 and 2, wherein the cam surface is substantially elliptical.
4. A dry shaver as claimed in any of claims 1 to 3, wherein the cam follower comprises a pivotable lever having a first arm (14;42) mounting a wheel (12;45) in contact with the cam surface, and a second arm (15;43) coupled to the reciprocating cutter.
5. A dry shaver as claimed in claim 4, wherein the wheel is biased into contact with the cam surface by means of a spring (17).
6. A dry shaver as claimed in claim 5, wherein the spring is a compression spring whose initial force is adjustable by means of a set screw (18).
7. A dry shaver as claimed in claim 4, wherein the pivotable lever further comprises a third arm (44), the first and third arm each mounting a wheel (45,46).
8. A dry shaver as claimed in any of claims 4 to 7, wherein the surface of the or each wheel which is in contact with the cam surface is made of an elastic material (26).
9. A dry shaver as claimed in any of claims 4 to 8, wherein at least the first arm is elastic.
10. A dry shaver as claimed in any of claims 4 to 9, wherein the or each wheel is elastically mounted on the respective arm.

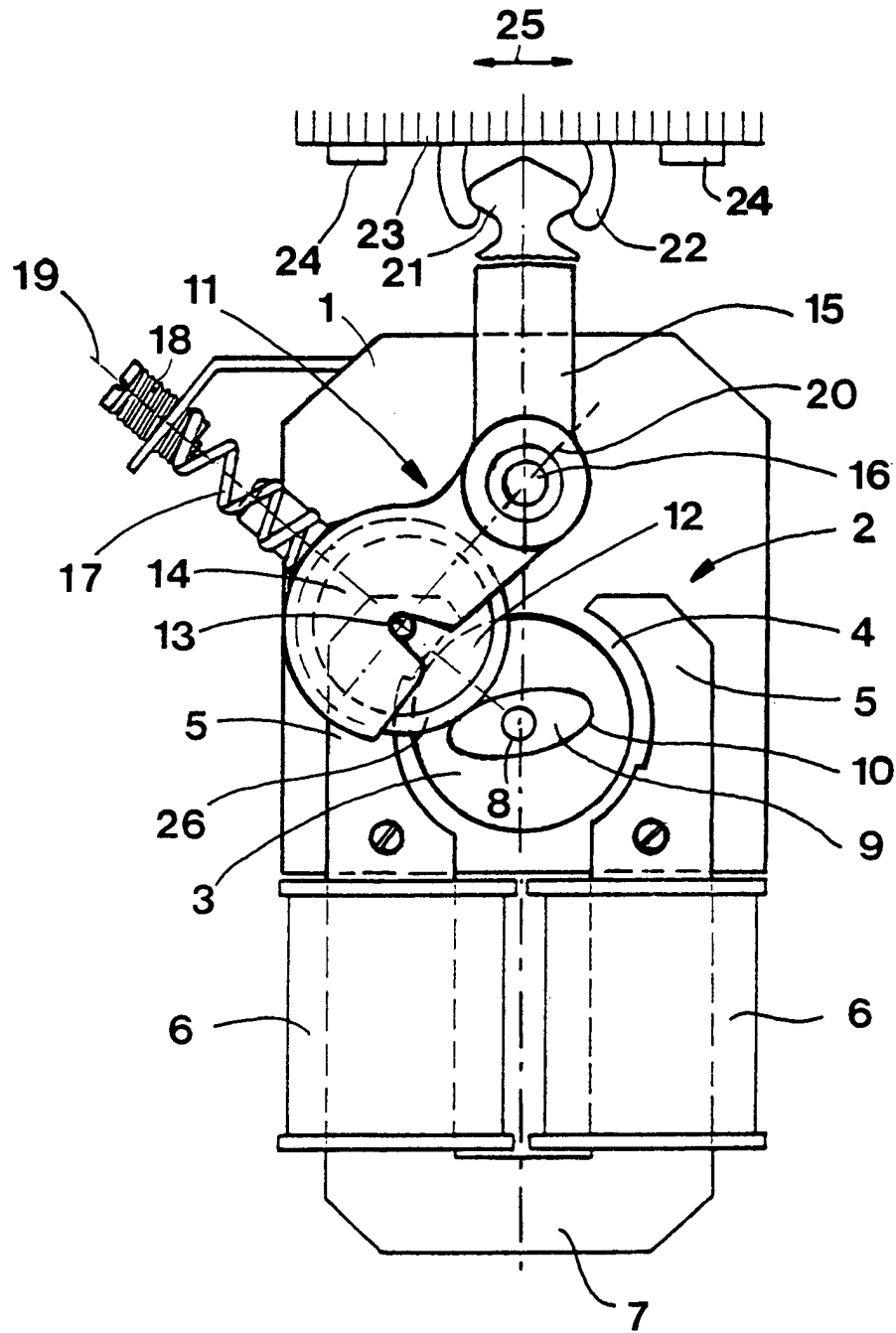

Fig. 1

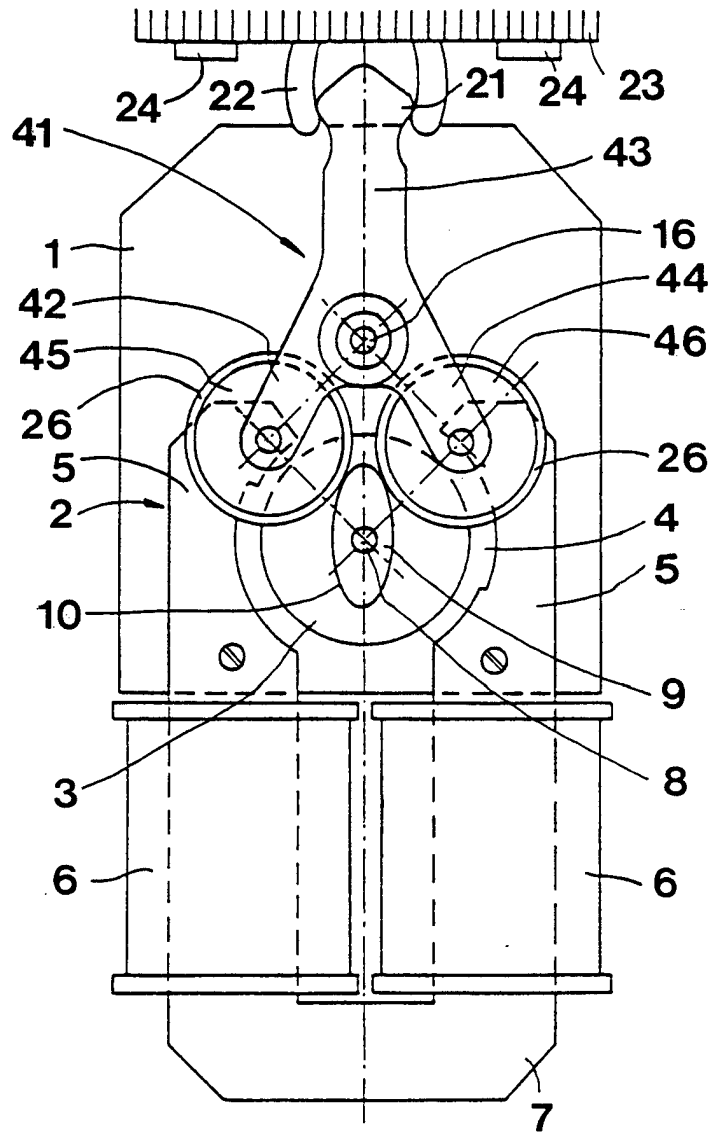

Fig. 2

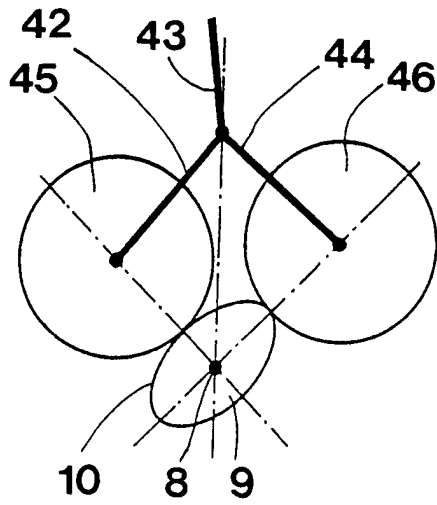

Fig. 2a

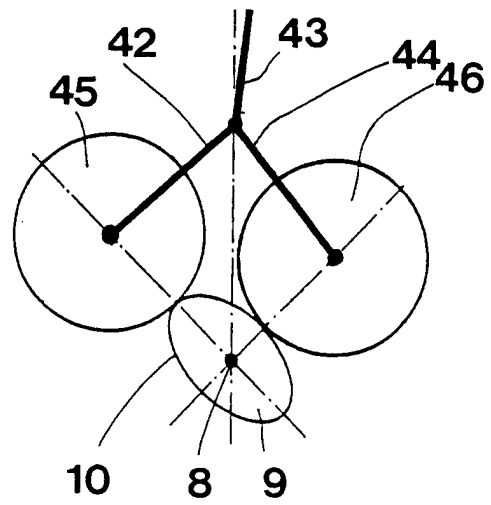

Fig. 2b

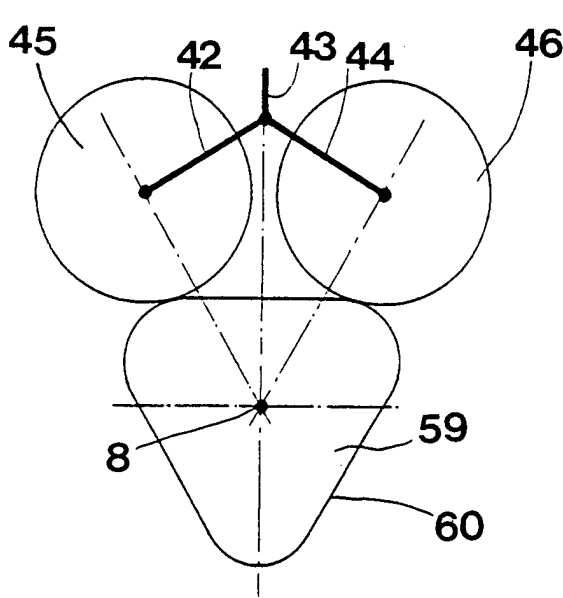

Fig. 3

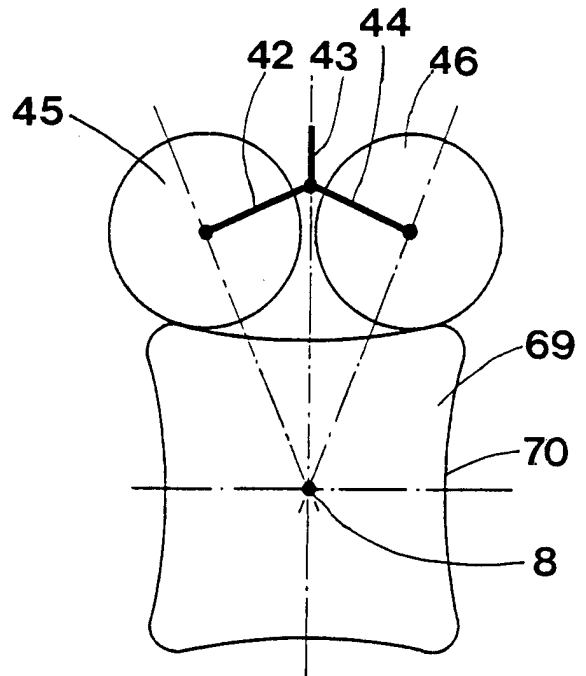

Fig. 4

COMMUNICATION

The examination is being carried out on the following application documents:
the examination documents as originally filed.

- 1) Documents II and III, both published before the filing date of the present application, are referred to in the present communication.
- 2) Using the terminology of claim 1 of the present application, Document II discloses (the reference numerals are those of Document II) a dry shaver comprising a motor (1) having a rotor (2), a reciprocating cutter (17) and a drive mechanism connecting the rotor to the reciprocating cutter and converting rotary motion to reciprocating motion, wherein the drive mechanism comprises a cam (7) having a cam surface (8) coupled to the rotor and a cam follower (9) cooperating with the cam surface and coupled to the reciprocating cutter. The subject-matter of claim 1 thus lacks novelty and the claim is not allowable in view of Articles 52(1) and 54 EPC.
- 3) In a dry shaver, in order to achieve the necessary cutting action, it is necessary to reciprocate the cutter at a sufficiently high speed. Such a speed is not directly obtainable from single phase synchronous motors. Accordingly, it is an essential feature of the claimed device that the cam surface is such as to cause the cam follower to oscillate at at least twice the frequency of rotation of the rotor. However, claim 1 is silent about this feature. Claim 1 therefore does not satisfy the requirements of Article 84 EPC.

It may be noted that claim 1 would nevertheless lack novelty in view of Document II even if this feature was incorporated therein.

- 4) The subject-matter of claims 2, 3, 5, 6 and 8 is also known from Document II, so that these claims are similarly not allowable in view of Articles 52(1) and 54 EPC.

- 5) The cam follower (9) of Document II has a wheel (12) mounted thereon which is in contact with the cam surface (8) and is further coupled to the reciprocating cutter (17). The arm (11) of the cam follower of Document II is the mechanical equivalent of two arms, and, indeed, the arm (11) could be replaced by two separate arms, one mounting the wheel (12) and the other being coupled to the reciprocating cutter (17) without affecting the functioning of the device. The subject-matter of claim 4 thus adds nothing inventive to the claims to which it is appendant.
- 6) Document III discloses a dry shaver in which the cam follower comprises three arms (9,10,16), two of which mount a respective wheel (11,12). Thus, the person skilled in the art, faced with the problem of adjustment of the initial force of the spring (13) of the appliance of Document II, would readily find the solution to this problem in Document III, according to which a spring is not necessary in view of the provision of a second wheel on the cam follower. The subject-matter of claim 7 thus adds nothing inventive to the claims to which it is appendant.
- 7) According to the teaching of Document II, it is desirable either to make the wheel itself of an elastic material or to provide an elastic ring or tyre around the wheel. To make the arm on which the wheel is mounted elastic, or to mount the wheel in an elastic manner, is an obvious mechanical equivalent to these measures which comes within the scope of customary practice followed by persons skilled in the art. Whichever arrangement is chosen, the effect will be the same, that is, a certain degree of resilience is provided in the drive mechanism to ensure that the wheels remain in contact with the cam surface. The subject-matter of claims 9 and 10 thus adds nothing inventive to the claims to which they are appendant.
- 8) The subject-matter of claims 4, 7, 9 and 10 thus does not involve an inventive step and these claims are not allowable in view of Articles 52(1) and 56 EPC.
- 9) In view of the above, none of the claims as filed are allowable. If, however, you are of the opinion that the present application includes patentable subject-matter, you are invited to file your observations and arguments, together with any amendments to the claims.

DOCUMENT I (State of the Art)

(This document is identical to Document I in Paper A)

The invention relates to a dry shaving apparatus for connection to an ac mains source.

Such dry shavers are generally powered by a single phase synchronous motor. The motor comprises a rotor in the form of a permanent magnet and a stator in the form of a U-shaped ferrous core having two pole pieces, one on each side of the rotor and separated therefrom by an air gap. Each pole piece is provided with a coil fed with single phase ac mains current, which has a frequency of 50 Hz in Europe and 60 Hz in the United States. The continuous reversal of the direction of current flow causes the rotor to rotate at the ac frequency, since it requires one positive and one negative half wave to cause a 360° turn of the permanent magnet rotor. Thus, at 50 Hz, the motor will run at 50 revolutions per second. The constant speed makes the provision of a speed regulator unnecessary.

Such single phase synchronous motors are comparatively cheap, but have a long working life, in view of the fact that it is not necessary to supply any current to the rotor, so there is no necessity for the provision of brushes or other contacts which cause friction and wear over time. A disadvantage of such motors is that the motor speed is not fast enough to reciprocate the cutter element of a dry shaver sufficiently quickly.

The present invention overcomes this problem by the provision of a drive mechanism utilising such a single phase synchronous motor, but which is capable of reciprocating a cutter element at whatever speed is desired. The ac mains frequency varies from country to country, and the present invention permits a simple modification of the drive mechanism to select the desired reciprocation speed.

In the single Figure of the accompanying drawing, there is shown a plan view of a dry shaving apparatus according to the invention with a part of the housing removed.

A synchronous motor 1 comprises a permanent magnet rotor 2 rotatably mounted in an air gap 3 between two pole pieces 4. An exciter coil 5 is mounted on each pole piece and the pole pieces are connected by a stator iron 6. The exciter coils are connected to a socket 24 to enable them to be

connected to an ac mains source. The motor drives a first gear wheel 7 by means of a drive shaft 8. The first gear wheel 7 meshes with a second gear wheel 9, which is rotatably mounted on a spindle 10 in a housing 10 by means of a spindle 11. A first lever 12 is pivotably connected to the second gear wheel 9 by means of a pin 13 eccentrically mounted on the second gear wheel 9. A second lever 14 is connected to the first lever 12 by means of a hinge 15 and is pivotably mounted to the housing 10 by means of a bearing 16.

The free end of the second lever 14 is connected to a cutter element 17 by means of a ball 18 provided on the free end of the second lever, which is received in a sleeve 19 forming part of the cutter element 17. The cutter element 17 is mounted on the housing 10 by means of springs 20 which extend between the cutter element and blocks 21 formed on the housing, which permits the cutter element to reciprocate between two extreme positions. A stainless steel foil 22 (shown partly removed) is positioned over the cutter element and mounted in a shaving head 23 detachably mounted on the housing 10.

15

By the selection of gear wheels 7 and 9 having an appropriate gear ratio, the speed of rotation of the second gear wheel, and hence the rate of reciprocation of the cutter element, can be varied. For use in countries with a 50 Hz mains source, it is necessary to at least double the speed of rotation of the first gear wheel 7, so that the second gear wheel 9 should have at most half the number of teeth of the first gear wheel 7.

20

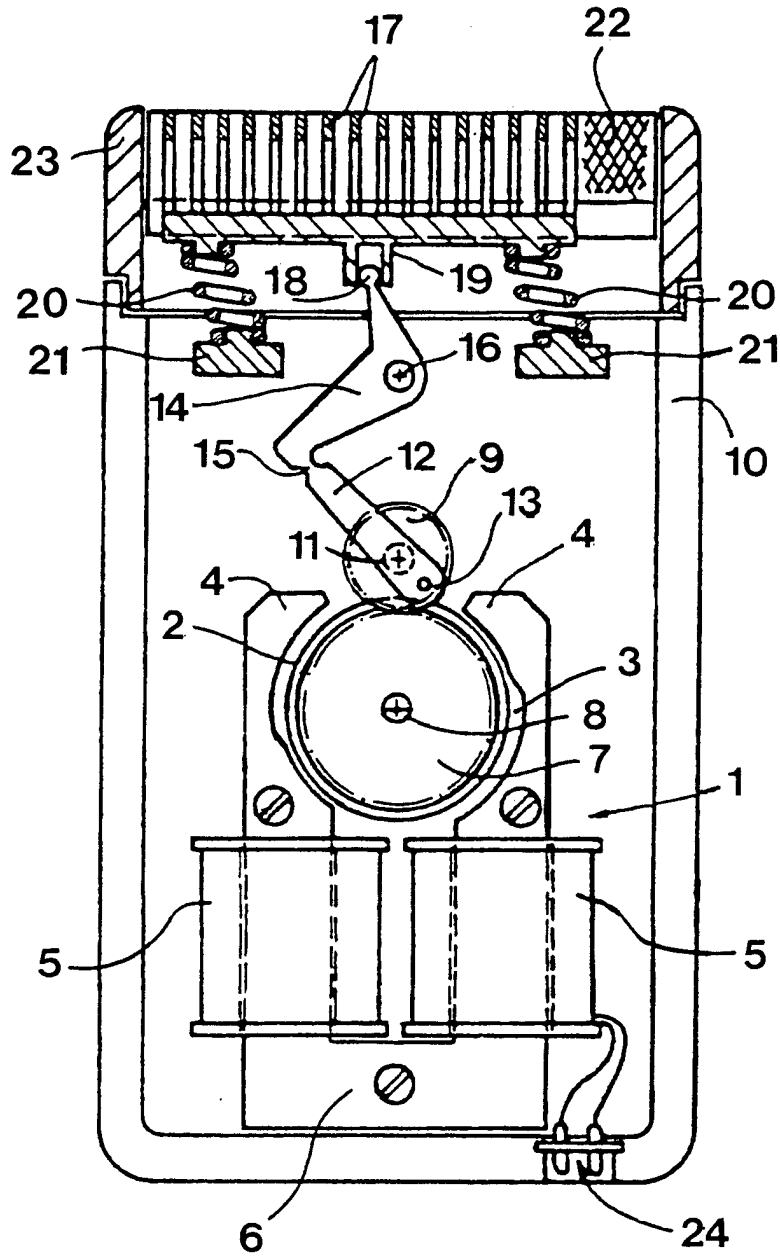

DOCUMENT II (State of the Art)

This invention relates to a drive mechanism for a dry shaver or other domestic appliance in which the rotary motion of a motor is converted into reciprocating motion.

It is desirable for such domestic appliances to be compact and to fit comfortably in the hand of a user. The configuration of the drive mechanism according to the present invention enables its use in a compact appliance.

The invention will become apparent from a reading of the subsequent description in conjunction with the accompanying drawing, in which:-

the single Figure is a plan view of a preferred embodiment of the drive mechanism in accordance with the invention.

A synchronous motor 1 comprises a permanent magnet rotor 2 rotatably mounted in an air gap 3 between two pole pieces 4. An exciter coil (not shown) is mounted on each pole piece and the pole pieces are connected by a stator iron 5.

A drive shaft 6 projects from the rotor 2 and carries a cam 7 having a cam surface 8. A cam follower 9 is pivotably mounted about a pivot 10 and comprises a lever 11 on which a wheel 12 is rotatably mounted. The wheel is preferably made of an elastic material in order to reduce wear and to reduce noise. Alternatively, the wheel 12 may be provided with an elastic ring or tyre. The wheel is biased into contact with the cam surface 8 of the cam 7 by means of a compression spring 13. The initial force of the spring 13 is adjustable by means of a set screw 14.

The free end of the lever 11 is provided with a driving member 15 which engages with a gripping member 16 of a cutter 17. Guide means 18 restrain the cutter 17 to movement in the direction indicated by arrow 19.

Thus, as the cam 7 is rotated by the motor 1, the cam follower 9 undergoes a reciprocating movement which is transmitted to the cutter 17 which reciprocates in the direction of the arrow 19.

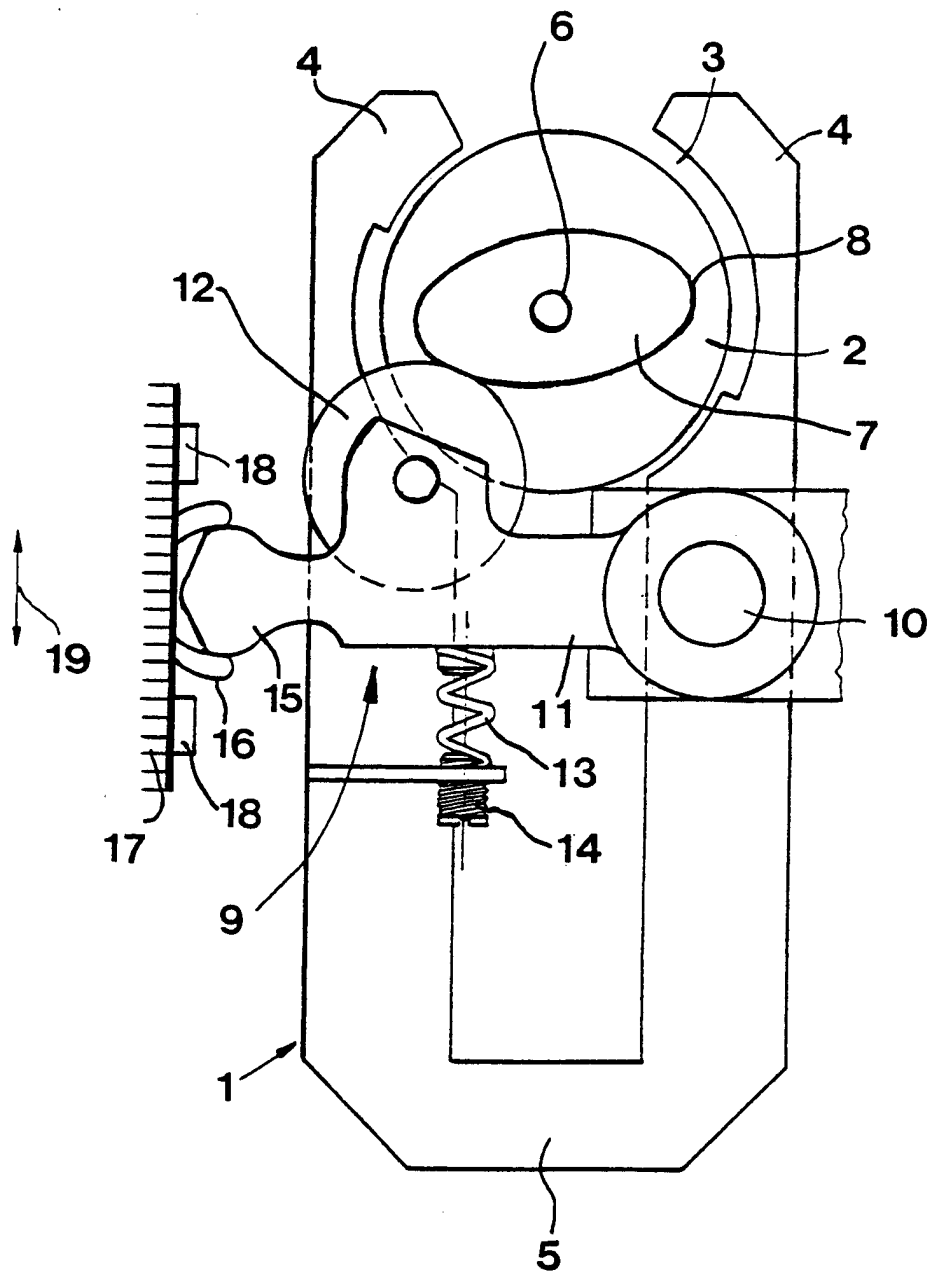

DOCUMENT III (State of the Art)

This invention relates to electric dry shavers.

It is an object of the present invention to provide a shaver which is powered by a single-phase synchronous motor.

5

The sole Figure of the accompanying drawing shows a plan view of an embodiment of the present invention, with a part of the housing removed.

The shaver comprises a housing 1 in which a single-phase synchronous motor 2 is mounted. Such
10 motors are well known to the person skilled in the art, and will not be described here in detail.

The rotor 3 of the motor 2 drives a shaft 4, on which are mounted two elliptical cams 5,6 at right angles to one another. The shaft extends out of the plane of the drawing, and the cam 5 is mounted on the shaft 4 above the cam 6, so that the two cams do not lie in the same plane.

15

A cam follower 7 comprises a plate 15 on which a bridge 8 having two arms 9,10 is rigidly mounted. A wheel 11,12 is mounted on each of the arms 9,10. The wheel 11 is in contact with the cam 6 and the wheel 12 is in contact with the cam 5. In the illustrated position of the shaver, the cam follower is in its extreme left hand position, owing to the fact that the wheel 11 is in contact with the portion of
20 cam 6 having the greatest diameter and the wheel 12 is in contact with the portion of cam 5 having the smallest diameter. It will be appreciated that, as the shaft 4, together with the two cams 5,6 rotates from its illustrated position, the cam follower 7 will be moved towards the right. Each wheel is thus retained in contact with its respective cam without the use of springs.

25 The plate 15 is mounted on the housing 1 by means of guide means 13,14 and mounting blocks 21 so that the entire cam follower 7 is constrained to oscillate in the direction indicated by arrow 24.

There is further provided an arm 16 on the plate 15, the free end 17 of which is received in a sleeve 18 mounted on a cutter member 19. The cutter member 19 is mounted on the housing 1 by
30 means of two coil springs 20 which connect the cutter member to the two mounting blocks 21

forming part of the housing. A shear foil 22 is mounted in a shaver head 23 so as to cooperate with the cutter member when the shaver head 23 is mounted on the housing 1.

Oscillatory movement of the plate 15 is thus transmitted to the cutter member 19 which cooperates with the shear foil 22 so as to cut hairs.

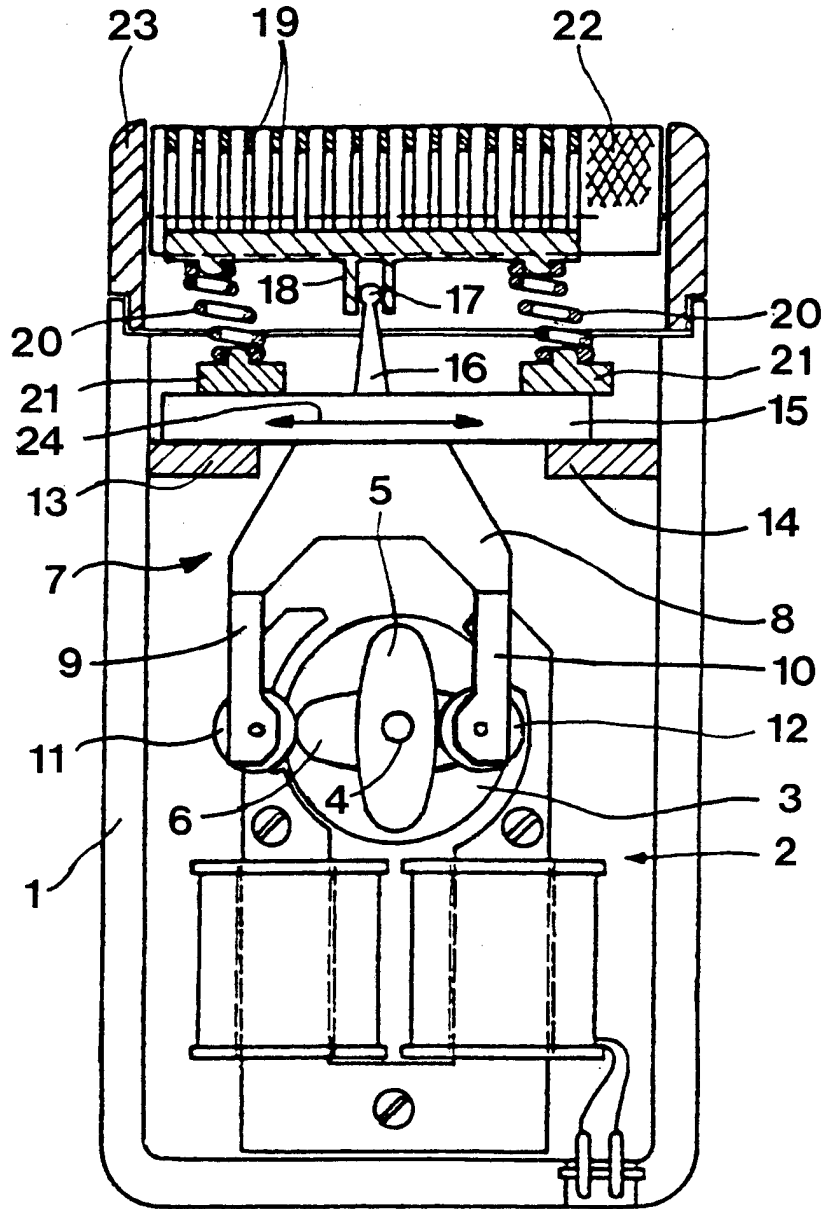

CLIENT'S LETTER

Thank you for your letter forwarding a copy of the official communication from the European Patent Office as well as the Documents II and III.

It does appear that the examiner is partially correct, insofar as our basic idea of using a cam arrangement with a spring-biassed cam follower is already known. If this means that we cannot obtain protection for the arrangement shown in Figure 1 of our application, then so be it. The need to adjust a set screw on each appliance as its comes off the assembly line is really inconvenient, and we are thinking of dropping this concept from our product range.