

EUROPEAN QUALIFYING EXAMINATION 1996

PAPER B ELECTRICITY/MECHANICS

This paper comprises:

- | | |
|---|-------------------|
| * Instructions to Candidates | 96/B(E/M)/e/1 |
| * Client's Letter | 96/B(E/M)/e/2 |
| * Description of the Application | 96/B(E/M)/e/3-11 |
| * Claims | 96/B(E/M)/e/12 |
| * Drawings of the Application | 96/B(E/M)/e/13-17 |
| * Communication | 96/B(E/M)/e/18-19 |
| * Document I (State of the Art) | 96/B(E/M)/e/20-21 |
| * Drawings of Document I (State of the Art) | 96/B(E/M)/e/22 |
| * Document II (State of the Art) | 96/B(E/M)/e/23-24 |
| * Drawings of Document II (State of the Art) | 96/B(E/M)/e/25-26 |
| * Document III (State of the Art) | 96/B(E/M)/e/27-28 |
| * Drawings of Document III (State of the Art) | 96/B(E/M)/e/29 |

INSTRUCTIONS TO CANDIDATES

In this paper, you should assume that a European patent application for all the Contracting States comprising the appended documents(*) has been filed and that the European Patent Office has issued the annexed official communication. The paper may include a client's letter containing instructions about the way your client wishes to prosecute the European patent application.

You should accept the facts given in the paper and base your answers upon such facts. Whether and to what extent these facts are used is your responsibility.

You should not use any special knowledge you may have of the subject-matter of the invention, but are to assume that the prior art given is in fact exhaustive.

Your task is now to draft a full response to the official communication. The response should be a letter to the EPO, accompanied, if appropriate, by an amended set of claims. No amendments to the description should, however, be made.

The claims should afford the broadest protection possible while meeting the requirements of the Convention. In your letter of response you should set out your arguments in support of the patentability of the independent claim(s).

If you consider that any part of the application ought to be made the subject of one or more divisional applications, you should in a note, clearly identify the subject-matter of the independent claim of such divisional application(s) and the justification for this. However, it is not necessary to draft the wording of the independent claim for the or each divisional application.

In addition to your chosen solution, you may - but this is not mandatory - give, in a note, the reasons for your choice of solution, for example, why you selected a particular form of claim, a particular feature for an independent claim, a particular piece of prior art as starting point or why you rejected or preferred some piece of prior art. Any such note should however be brief.

It is assumed that you have studied the examination paper in the language in which you have given your answer. If this is not so, please indicate on the front page of your answer in which language you have studied the examination paper. This always applies to candidates who - after having filed such a request when enrolling for the examination - give their answer in a language other than German, English or French.

(*) These documents do not necessarily constitute the only or best solution to the task set in Paper A.

CLIENT'S LETTER

Thank you for your letter forwarding a copy of the official communication from the European Patent Office as well as the Documents II and III.

We have shown the communication to the inventors and they admit that the examiner's comments in paragraph 4 of the communication are correct. It would be difficult to pretend that it would require an inventive step to use contactless detecting means such as those disclosed in the application in place of the brushes of the device of Document II.

On the other hand, we are still interested in the subject of the present application which is very successful and, incidentally, profitable. In particular, we are of the opinion that our transducers are superior to those of the known devices. In the case of the device of Document III, the form of the signals produced by the encoder discs necessitates the use of a complicated signal processor.

We would therefore be grateful if you could take the necessary steps to obtain the best patent protection for our invention whilst avoiding unnecessary expense.

DESCRIPTION OF THE APPLICATION

The present invention relates to cursor control devices for use with computers and more particularly personal computers (PCs). In many computer systems, software options can be executed by selecting corresponding graphic representations displayed on the screen of a monitor. Such graphic representations are generally called "icons". A particular software option represents a task or program which can be executed by the computer system. By selecting one or several of the software options, the computer system can be operated in a desired manner.

A particular software option can be selected by moving a cursor displayed on the screen such that it indicates the corresponding icon. By providing an execution command, the selected software option will be executed by the computer system. The cursor generally takes the form of a short line, a patch or an arrow displayed on the screen.

For displacing the cursor on the screen an operator may use the four "arrow" keys provided on a conventional computer keyboard, that is, two keys for moving the cursor up and down, and two keys for moving the cursor to the left and right. The "enter" key of the keyboard may be used for providing the execution command.

However, the use of such keys has proven not to be efficient in cases wherein a user has to choose repetitively software options. For this purpose, cursor control devices in the form of mouse and trackball devices have been developed.

A typical computer mouse comprises a freely rotatable ball which rotates as the mouse is moved over a support surface, such as a desktop surface or a table. The ball is associated with first and second potentiometers which produce electrical signals which control the position of the cursor on the screen. The ball and the potentiometers are contained in a housing which has an opening through which the ball partly projects.

By moving the mouse in a desired direction, the ball is caused to roll on the support surface, which changes the electrical signals from the potentiometers. These electrical signals are converted into a corresponding position of the cursor on the screen. Accordingly, the cursor can be displaced on

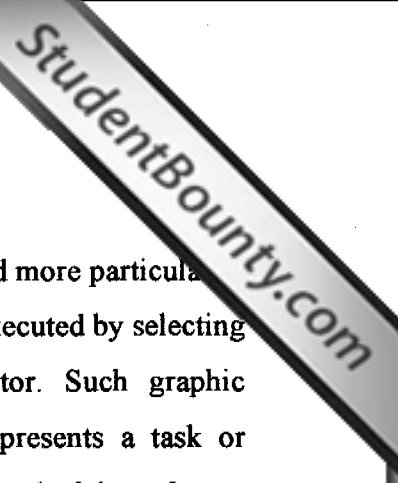

the screen by a corresponding displacement of the mouse over the support surface. By a button mounted on the housing of the mouse, the user can command the computer to execute a software option which corresponds to the icon indicated by the cursor.

5 Trackball devices have a somewhat similar construction to a mouse. However, instead of the housing being moved by the user, the ball is rotated directly by the user while the housing remains stationary, for example, fixedly attached to the computer housing.

Document I discloses a cursor control device for a computer, the cursor control device comprising
10 a housing containing a freely rotatable ball and first and second transducers associated with the ball, the housing having an opening through which the ball partly projects. The transducers are in the form of potentiometers. This device, however, suffers from the problem that it has a limited reach, i.e. when the device is moved such that the wiper of the potentiometer reaches an end position, the
15 cursor cannot be moved further in that particular direction. In addition, potentiometers are inherently inaccurate, which inaccuracy becomes worse over time due to the penetration of dust and wear.

According to the invention, these problems are overcome in that each transducer comprises means for translating rotation of the ball into at least one signal comprising a number of pulses corresponding to the amount of rotation of the ball.

20 Preferred features of the invention are the subject of dependent claims.

In the accompanying drawings:

25 Fig. 1 is a perspective view of a computer system including a cursor control device in the form of a mouse in accordance with the present invention;

Fig. 2 is a schematic view illustrative of the principle of operation of the cursor control device of the present invention;

30 Fig. 3 is a perspective view of the mouse of Fig. 1 with the cover raised;

Fig. 4 is a top view of part of the internal structure of the mouse of Fig. 3, with the cover thereof removed;

Fig. 5 is a schematic illustration, on an enlarged scale, of part of a transducer used in the mouse of Fig. 3;

Fig. 6 is a schematic illustration of part of an alternative form of transducer which may be used in the mouse of Fig. 3;

Fig. 7 is a top view of a trackball device according to the present invention, with the cover thereof removed;

Fig. 8 is a view in vertical section of the trackball device of Fig. 7 taken along the line VIII-VIII, with the cover in place; and

Fig. 9 is a diagram showing signals produced by the transducer of either Fig. 5 or Fig. 6.

In the drawings, corresponding parts are indicated by the same reference numeral.

The computer system 1 illustrated in Fig. 1 comprises a processor 2 and a screen 3, both mounted in a housing 4 positioned on a table 5. The computer system 1 includes a keyboard 6 and a cursor control device according to the present invention in the form of a mouse 7. The keyboard 6 and the mouse 7 are connected to control inputs of the processor 2 via cables 8,9, respectively.

In operation, the mouse 7 is operated by a user on a support surface 10 placed on the table 5. The movement of a cursor 11 in the form of an arrow on the screen 3 is governed by the movement of the mouse 7. That is to say, the mouse 7 generates electrical signals controlling the movement of the cursor 11 in such a manner that the displacement of the cursor 11 on the screen 3 corresponds to the displacement of the mouse 7 in a desired direction over the support surface 10.

During use, the processor 2 generates signals that define graphic representations or icons 12 corresponding to particular software options to be executed by the computer system 1. Such software

options occur during the execution of, for example, a file management program, a print program or a word processing program. By positioning the cursor 11 on a particular icon 12 on screen 3, the corresponding software option can be executed by actuating a button 13 provided in the housing 14 of the mouse 7.

5

The principle of operation of the cursor control device of the invention will be described with reference to Fig. 2.

10 A ball 15 is biased against first and second rollers 16,17 by a biasing roller 18. The first and second rollers 16,17 are supported for rotation about first and second axes 19,20 respectively which are schematically illustrated by dash-dot lines. The axes 19,20 extend perpendicularly to each other and the first and second rollers 16,17 are in contact with the surface of the ball 15. Rotation of the ball 15 causes a corresponding rotation of one or both of the rollers 16,17.

15 The biasing roller 18 is located on a straight line 21 passing through a point P where the axes 19,20 intersect and the centre O of the ball 15 for biasing the ball 15 against the first and second rollers 16,17 under equal forces. The biasing roller 18 is rotatably supported by a holder 22 biased by a spring 23 supported by the housing 14 for resiliently biasing the ball 15 against the first and second rollers 16,17.

20

The first and second rollers 16,17 have shafts 24,25 on which first and second transducers 26,27 are mounted, respectively. When the ball rotates, the first and second transducers 26,27 translate the angles through which the shafts 24,25 rotate into corresponding electrical signals. These signals are indicative of the x- and y- components of the movement of the mouse in a Cartesian coordinate system.

25

Figs. 3 and 4 show in more detail the mouse 7 of Fig. 1. The housing 14 of the mouse has a cover 28 and a base 29 upon which the elements shown in Fig. 2 are disposed.

30 A frame 30 is provided which includes a dome 31 containing the ball 15 and having three apertures 32,33,34. The planes of the apertures 32,33 are disposed at 90 degrees with respect to one

another, and aperture 34 is oriented symmetrically opposite the other apertures 32,33, for
line 21 of Fig. 2.

The frame 30 is mounted on a printed circuit board 35 carrying electrical components 36 of the
5 mouse. The connection cable 9 is connected with the printed circuit board through an electrical
connector 37.

As illustrated in Fig. 4, two pairs of photo-emitters 40a,40b are mounted on the frame 30.
Similarly, two pairs of photo-detectors 41a,41b are mounted on the frame 30, opposite the photo-
10 emitters 40a,40b such that the photo-emitters 40a face the photo-detectors 41a and the photo-
emitters 40b face the photo-detectors 41b.

Between the photo-emitters 40a,40b and photo-detectors 41a,41b, encoder discs 42,43 are provided,
axially coupled to the shafts 24, 25, respectively. Each encoder disc 42,43 is provided with a plural-
15 ity of radially disposed slots 44, such that a light beam generated by a photo-emitter 40a,40b and
directed to the corresponding photo-detector 41a,41b is passed or interrupted when the corresponding
encoder disc 42,43 rotates. The shafts 24,25 are coupled to the first and second rollers 16,17,
respectively. The first roller 16 is positioned in front of the aperture 32 and the second roller 17 is
20 positioned in front of the aperture 33, such that part of the circumferential surface of the first and
second rollers 16,17 extends within the interior of the dome 31. The facing photo-emitters 40a,40b
and photo-detectors 41a,41b and the encoder discs 42,43 form the transducers 26,27 of Fig. 2.

The ball 15 is disposed within the dome 31 of the frame 30. The ball 15 is maintained in contact
with both the first and second rollers 16, 17 through the biasing roller 18.

25 Different from the arrangement shown in Fig. 2, the biasing roller 18 is mounted on a flexible
shaft 50 and extends through the aperture 34 into the interior of the dome 31 to make contact with
the ball 15. The flexible shaft 50 is supported by bosses 48,49 and provides a biasing effect on the
ball 15.

As shown in Fig. 3, the button 13 extends through the cover 28 of the housing 1 to a switch 51. The switch 51 can be actuated by pushing the button 13.

Each encoder disc 42,43 interrupts two light-beams respectively from the photo-emitters 40a,40b. When, as illustrated in Fig. 5, the light-beam from the photo-emitter 40a is fully transmitted through a slot 44 of an encoder disc 42,43, the light-beam from the photo-emitter 40b is partially blocked. In the preferred embodiment, the photo-emitters and detectors operate in the infrared region. However, it will be appreciated that any suitable light wavelength may be used.

The light-beam interruptions from the rotation of an encoder disc are detected by the photo-detectors 41a,41b which produce signals in the form of pulses. The form of these pulses is shown in Fig. 9 which shows the voltage of the signals plotted against time. A first signal 70 is produced by the photo-detector 41a. A second signal 71 is produced by the photo-detector 41b. At the instant 72, the signal 70 is at its maximum intensity, corresponding to the light beam being fully transmitted as illustrated in Fig. 5, whilst the second signal 71 lags behind the first signal, the light beam being only partially transmitted. The number of pulses, i.e. the number of times the light beam is transmitted or interrupted, is a measure of the amount of rotation of the encoder disc and hence the distance which the mouse is displaced over the support surface. From the order in which the light-beams of the photo-emitters associated with a particular encoder disc are interrupted, the direction of rotation of the encoder disc may also be determined. It will be appreciated that this effect could not be obtained if the arrangement was such that the pulses were either simultaneous or equally spaced from one another.

It may further be noted that it would be possible to arrange a single photo-emitter such that the photo-detectors 41a,41b receive the light beams from the single photo-emitter.

From Fig. 5 it will be appreciated that during a clockwise rotation of the encoder disc 42 the light-beam of photo-emitter 40a will be interrupted a short time before the light beam of photo-emitter 40b, so that the photo-detectors 41a,41b produce the signals 70,71 as illustrated in Fig. 9. During an anti-clockwise rotation, the light beam of photo-emitter 40b will be interrupted a short time before the light beam of photo-emitter 40a, so that signal 71 precedes signal 70. Thus, the

Fig. 7 shows an embodiment of the cursor control device according to the present invention in the form of a trackball device 60. The device includes a ball 15, first and second rollers 16,17, a biasing roller 18, arranged as shown in Fig. 2. Encoder discs 42,43 coupled with the first and second rollers 16,17 and photo-emitter/detector combinations 40,41 form the transducers 26,27. The several parts are mounted in a housing 62 having a bottom part 63 and a cover 64 (as shown in Fig. 8).

As can be seen from the vertical section of Fig. 8, beneath the shaft 61 of the biasing roller 18, the housing 62 is provided with a cylindrical bore 65 which extends substantially perpendicularly to the shaft 61 and receives therein a helical spring 66. The helical spring 66 imposes a biasing force on the ball 15 via the roller 18, to urge the ball 15 into contact with the first and second rollers 16,17.

In operation, the trackball device 60 is positioned as shown in Fig. 8.

List of reference numerals used

1	computer system	30	frame
2	processor	31	dome
3	screen	32,33,34	apertures
4	housing	35	printed circuit board
5	table	36	electrical components
6	keyboard	37	electrical connector
7	mouse	40,40a,40b	photo-emitters
8,9	cables	41,41a,41b	photo-detectors
10	support surface	42,43	encoder discs
11	cursor	48,49	bosses
12	icons	50	flexible shaft
13	button	51	switch
14	housing of the mouse	54	toothed encoder disc
15	ball	55a,55b	inductive detectors
16	first roller	56	permanent magnet
17	second roller	57	coil
18	biassing roller	58	teeth
19	first axis	60	trackball device
20	second axis	61	shaft
21	straight line	62	housing of trackball
22	holder	63	bottom part
23	spring	64	cover
24	first shaft	65	cylindrical bore
25	second shaft	66	helical spring
26	first transducer	70	first signal
27	second transducer	71	second signal
28	cover	72	instant
29	base		

CLAIMS

1. A cursor control device for a computer, the cursor control device comprising a housing (14) containing a freely rotatable ball (15) and first and second transducers (26,27) associated with the ball, the housing having an opening through which the ball partly projects, characterised in that each transducer comprises means for translating rotation of the ball into at least one signal (70,71) comprising a number of pulses corresponding to the amount of rotation of the ball.
2. A device as claimed in claim 1, wherein each transducer comprises a roller (16,17) in frictional contact with the ball, the axes (19,20) of the rollers being mutually perpendicular.
3. A device as claimed in claim 2, further comprising means (18) for biasing the ball towards the intersection of the axes of the rollers.
4. A device as claimed in any preceding claim, wherein each transducer comprises an encoder disc (42,43,54) arranged so as to rotate when the ball rotates and detecting means (40a,40b,41a,41b;40,41,44;56,57,58) for detecting rotation of the encoder disc and for generating a signal comprising a corresponding number of pulses.
5. A device as claimed in claim 4, wherein the detecting means comprises a photo-emitter (40a,40b) and a photo-detector (41a,41b) and the encoder disc has a plurality of radially disposed slots or apertures (44) arranged so that a light beam emitted by the photo-emitter and directed to the photo-detector is periodically interrupted when the encoder disc rotates.
6. A device as claimed in claim 4, wherein the encoder disc has a plurality of teeth (58) and the detecting means comprises a permanent magnet (56) and a coil (57), the teeth of the encoder disc causing variation in the magnetic field produced by the permanent magnet during rotation of the encoder disc, whereby a pulsed electromotive force is induced in the coil.
7. A device as claimed in any of claims 4 to 6, wherein the encoder disc is such that, in use, the at least one signal generated by each transducer is indicative of the direction of rotation of the encoder disc.

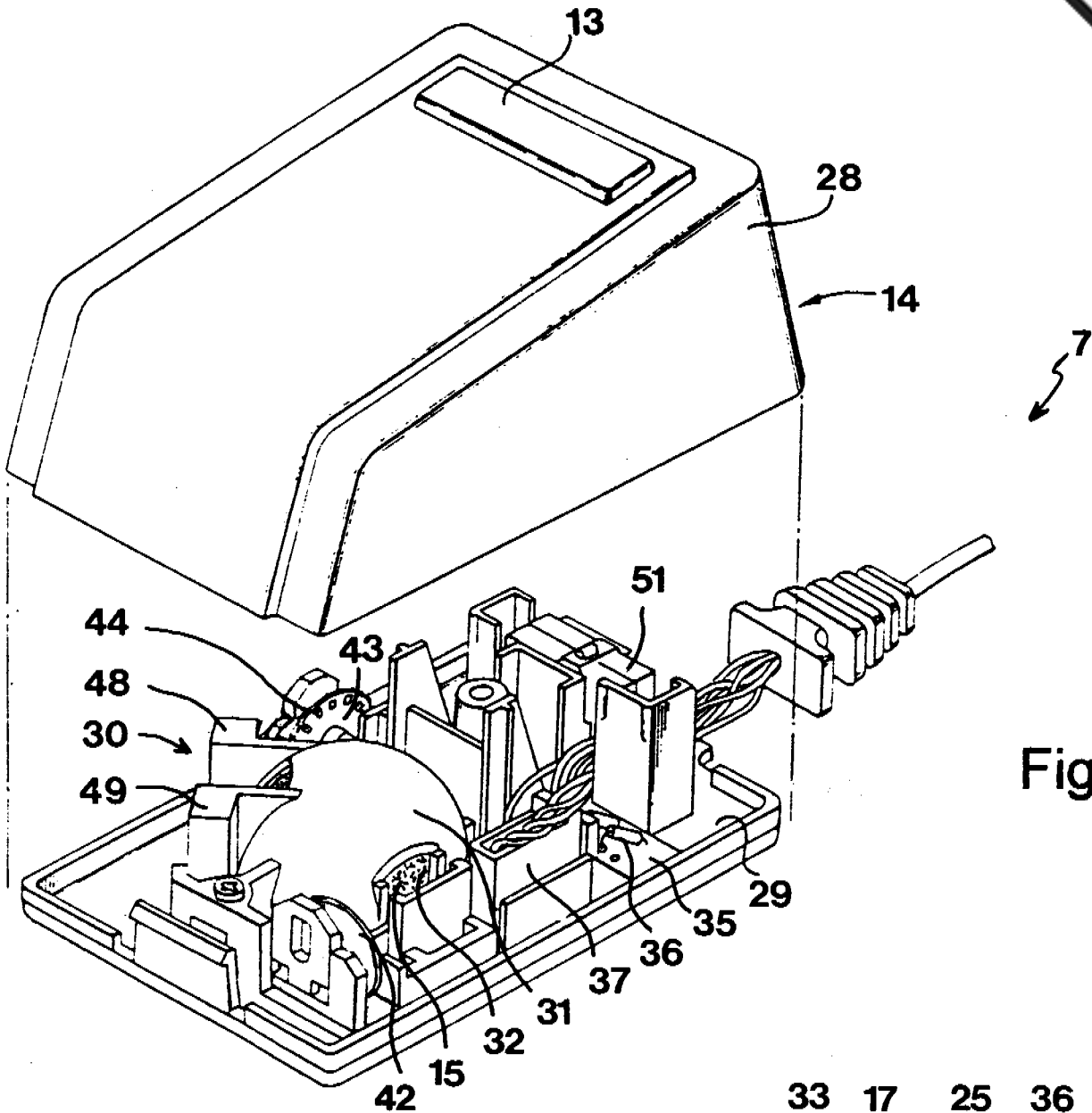

Fig. 3

Fig. 4

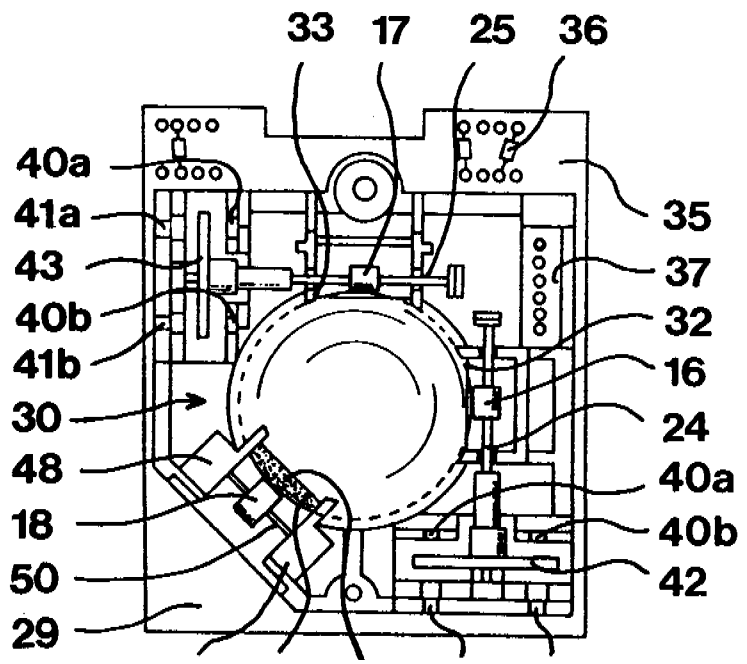

Fig. 5

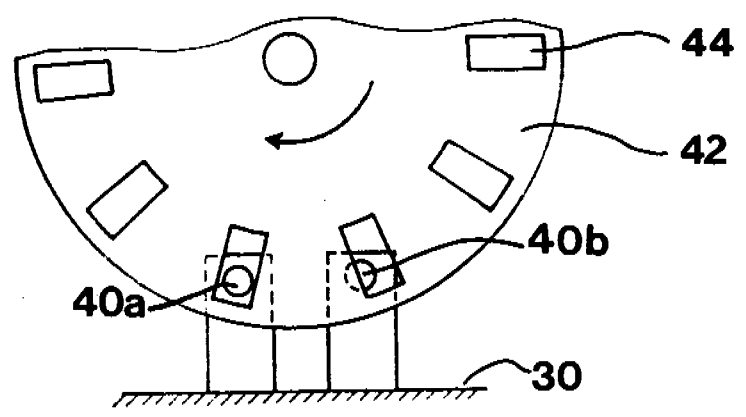
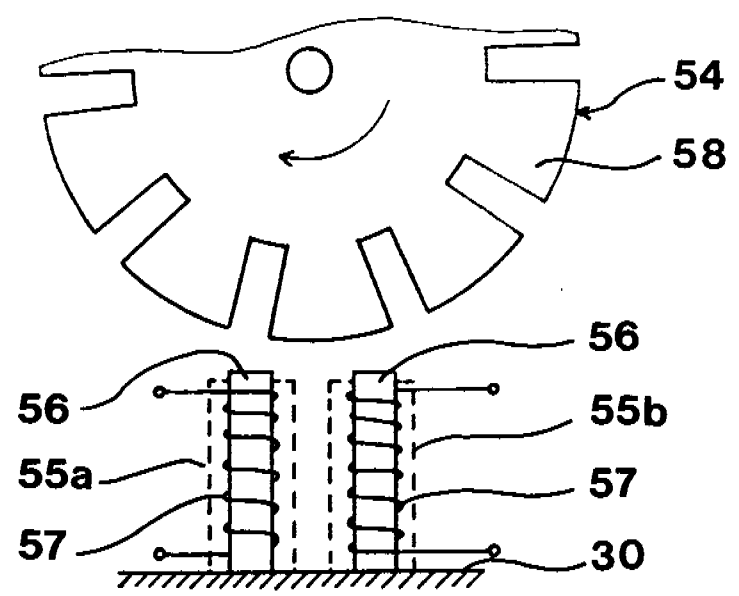
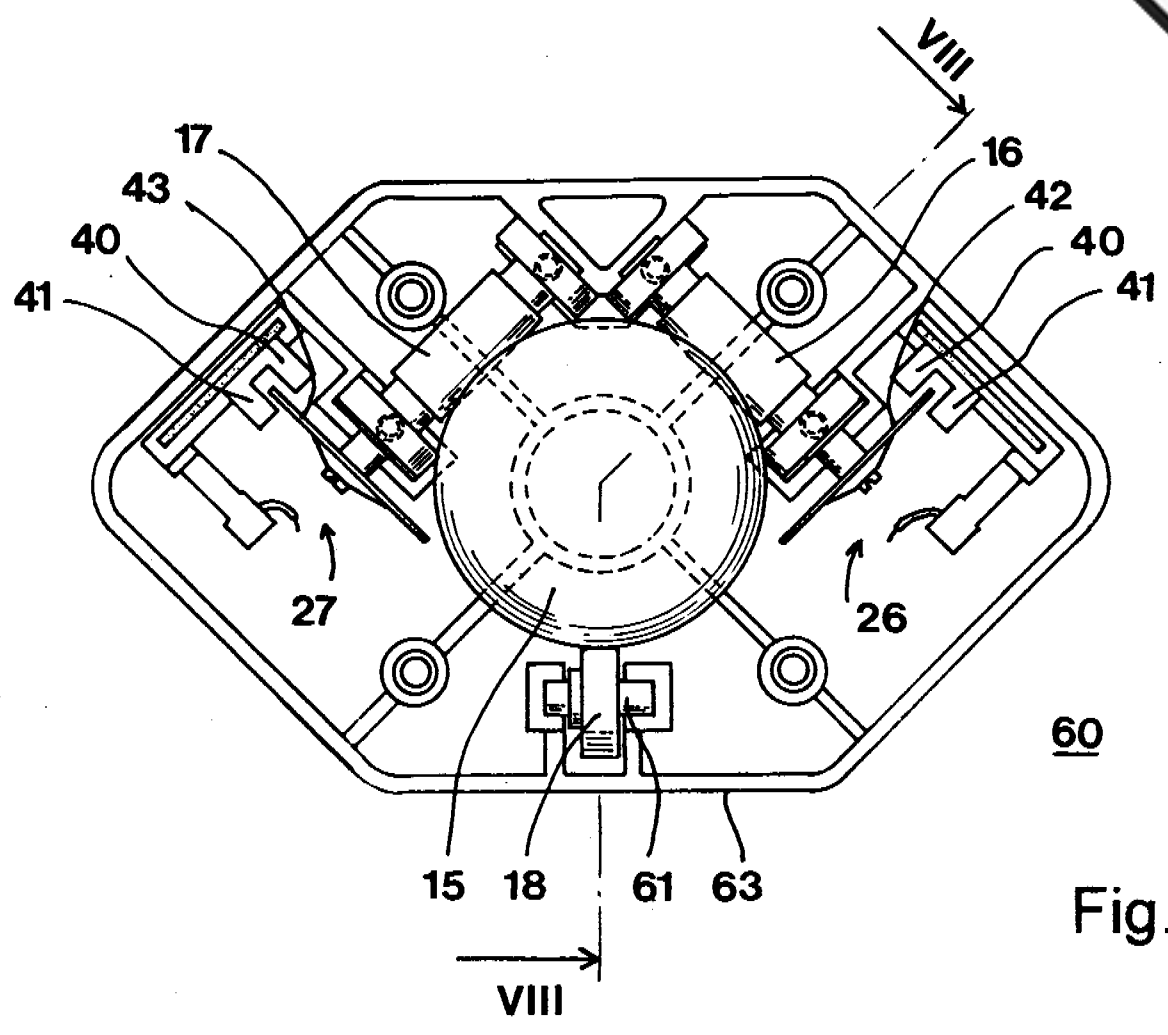

Fig. 6





60

Fig. 7

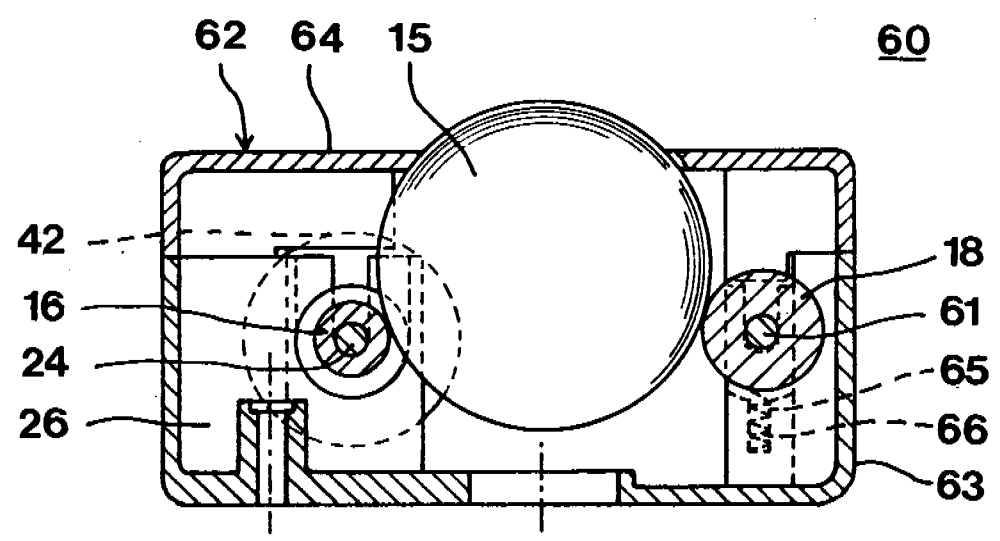

60

Fig. 8

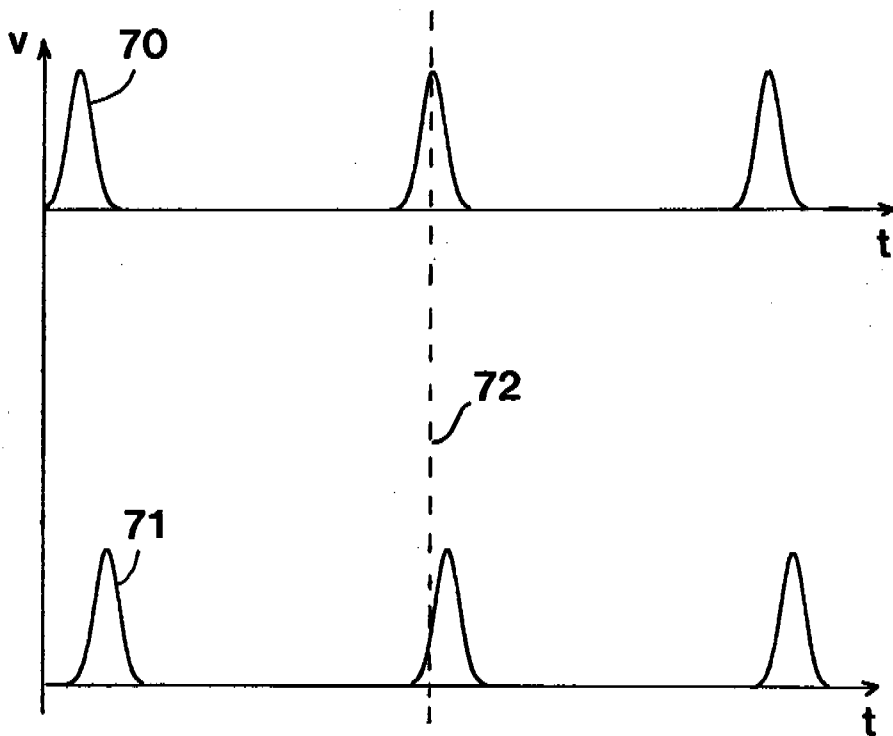
**Fig. 9**

COMMUNICATION

The examination is being carried out on the application documents as originally filed.

1) Documents II and III, both published before the filing date of the present application, are referred to in the present communication.

2) Using the terminology of claim 1 of the present application, Document II discloses (the reference numerals are those of Document II) a cursor control device for a computer, the cursor control device comprising a housing (2) containing a freely rotatable ball (3) and first and second transducers (4,5) associated with the ball, the housing having an opening through which the ball partly projects, wherein each transducer comprises means for translating rotation of the ball into at least one signal (17) comprising a number of pulses corresponding to the amount of rotation of the ball. The subject-matter of claim 1 thus lacks novelty and the claim is not allowable in view of Articles 52(1) and 54 EPC.

3) The subject-matter of claims 2 to 4 is also known from Document II, so that these claims are similarly not allowable in view of Articles 52(1) and 54 EPC. In the case of claims 2 and 3, it is pointed out that the force sensor (11) of Document II functions as a biasing means which biases the ball towards the intersection of the axes of the shafts (6,7) which function as rollers.

4) It is well known to the person skilled in the art that brush contacts can be replaced by contactless detecting means such as the optical transducer specified in claim 5, and disclosed, for example, in Document III, or the inductive detector specified in claim 6. The subject-matter of claims 5 and 6 thus adds nothing inventive to claim 4 and these claims are not allowable in view of Articles 52(1) and 56 EPC.

5) The device of Document II is rendered complicated and hence expensive by the provision of directional detectors (19,20) for indicating the direction of rotation in addition to the encoder disc

arrangement for indicating the amount of rotation. A solution to this problem is, however, disclosed in Document III, according to which the encoder disc (10,20) is such that, in use, the signal generated by the transducer is indicative of the direction of rotation of the encoder disc. The subject-matter of claim 7 thus adds nothing inventive to claims 4 to 6 and this claim is also not allowable in view of Articles 52(1) and 56 EPC.

6) In view of the above, none of the claims as filed are allowable. If, however, you are of the opinion that the present application nevertheless includes patentable subject-matter, you are invited to file your observations and arguments together with any amendments to the claims.

DOCUMENT I (State of the Art)

(This document is identical to Document I in Paper A)

The invention relates to display systems and, more particularly, to a position indicator device for controlling a cursor on a visual display, e.g. a monitor.

The invention will be better understood from the following description in conjunction with the
5 accompanying drawings.

Fig. 1 is an elevation partly in section of the position indicator device according to the present invention.

10 Fig. 2 is a top view partly in section of the position indicator device of Fig. 1.

Fig. 3 shows an electrical circuit forming part of the position indicator device of Figs. 1 and 2.

Referring to Fig. 1, the position indicator device 1 comprises a housing 2 which partly encloses a
15 ball 5. The housing has a dome-shaped cover part 3 which connects to a flat bottom part 4. A portion of the ball 5 extends through an aperture 6 in the bottom part 4. In use, this portion of the ball 5 is in contact with a support surface such a desk top (not shown).

A bearing 8 mounted on one side of a plate 9 embedded in the housing 2 restricts the movement
20 of the ball 5 in the upward direction viewed in the plane of Fig. 1. The ball 5 is constrained horizontally by wheels 10-13, which are rotatably mounted on respective housing flanges 14-17. Bearings 18-21 are disposed on the bottom part 4 of the housing 2 to prevent any undesired contact of the housing with the support surface.

25 A switch 22 is mounted on the other side of the plate 9 which can be actuated by a push button 23 slidably mounted in the cover part 3. The switch 22 may be used to command a processing device (not shown) to execute a software option corresponding to a position of the cursor.

As shown in Fig. 2, the wheels 10,13 are each connected to a respective potentiometer 24,25, that
30 is, a variable resistance as explained in more detail below, via rotatably mounted shafts 26,29. As

can be seen from Fig. 2, the shafts 26,29 are perpendicular to each other. The wheels 10,13 are mounted on shafts 26,29 and serve as supports for the ball 5 and rotate about shafts 27,28, respectively. The shafts 26-29 are supported by the respective housing flanges 14-17. The ball 5 and the wheels 10-13 may be of any material which ensures stable dimensions and avoids slippage between the wheels 10,13 and the ball 5.

The wheels 10,13 are position wheels, the position of which represents Cartesian x and y coordinates. As the position wheels 10,13 rotate upon a rotation of the ball 5 as a consequence of a movement of the position indicator device 1 over the support surface, the shafts 26,29 rotate, thus varying the resistances of the respective potentiometers 24,25.

As can be seen from Fig. 3, a voltage +V is connected via a supply terminal 30 to a first end terminal of each of the two potentiometers 24,25. A second end terminal of each potentiometer 24,25 is connected to a ground terminal 31. The wipers 36,37 of the potentiometers 24,25 are connected to output terminals 32,33, which provide x and y control signals respectively for controlling the position of the cursor in the x-y directions on the display, according to the movement of the position indicator device 1. The resistances of the potentiometers 24,25 measured between the wipers 36,37 and the second end terminals are indicated with reference numerals 34,35, respectively.

The wipers 36,37 are coupled to the shafts 26,29 of the potentiometers 24,25, respectively. Rotation of the shafts 26,29 causes the wipers 36,37 to move between a first end position, at which the wipers 36,37 connect directly to the supply terminal 30, and a second end position at which the wipers 36,37 connect directly to the ground terminal 31. The voltages at the output terminals 32,33 measured relative to the ground terminal 31 vary between +V and ground potential, and are dependent on the actual positions of the wipers 36,37. These voltages thus depend on the actual values of the resistances 34,35 of the potentiometers 24,25, respectively, and hence on the position of the position indicator device 1 on the support surface.

It should be noted that the user could also rotate the ball 5 by a finger or the thumb of the hand, so as to control the movement of the cursor on the display.

DOCUMENT II (State of the Art)

This invention relates to visual display systems and, more particularly, to devices for altering position of a cursor on the display.

A preferred embodiment of the invention in the form of a trackball device is shown in the accompanying drawings, in which:-

Figure 1 is a schematic view of the device, partly in section;

Figure 2 shows a transducer forming part of the device of Figure 1;

Figure 3 shows a force sensor also forming part of the device of Figure 1 and;

Figure 4 shows the output signals from an encoder disc and a directional transducer also forming part of the transducer of Figure 2.

As shown in Figure 1, a trackball device 1 comprises a housing 2 in which is provided a ball 3 which is freely rotatable by a user in any direction. First and second transducers 4,5 are provided for detecting rotation of the ball 3 in the x-y directions respectively. Each transducer comprises a shaft 6,7 in frictional contact with the ball 3 so as to be rotatably driven thereby. Each shaft 6,7 has a respective encoder disc 8,9 fixedly mounted thereon for generating signals 17 (see Figure 4) corresponding to the amount of rotation of the shaft 6,7. Each shaft 6,7 further has a directional detector 19,20 fixedly mounted thereon, each of which provides a signal 14 (see Figure 4) to a processor 10 upon rotation of the corresponding shaft 6,7. The signal 14 has a first value (for example 0) when the rotation is in a clockwise direction and a second value (for example 1) when

the rotation is in the opposite direction. By combining the signals 17 from the encoder disc 8 and the signals 14 from the directional detectors 19,20, the processor 10 generates signals representing a desired change of location of the cursor on the display.

5 The ball 3 is also movable in the z direction so as to actuate a force sensor 11 acting as a selection switch through a resiliently mounted bearing 12 in contact with the ball 3 as shown in Figure 3. In this way, a desired software option can be selected.

Referring now to Figure 2, a portion of the first transducer 4 is schematically illustrated, the second transducer 5 being similar. The encoder disc 8 has a circumferential track 13 of electrically conductive patches 15 (only some of which are fully shown). A brush 16 divided into two parts is connected to the processor 10. When the encoder disc 8 rotates in either direction as indicated by the arrow 18, the two parts of the brush 16 are connected by the patches 15 and a pulsed signal 17 is generated, each contact of the brush 16 with one of the patches 15 producing a pulse. The number of pulses generated is indicative of the amount of rotation of the encoder disc. From this information, together with the information regarding the direction of movement generated by the directional detector 19, can be derived the amount and direction of rotation of the ball in the x direction. When this information is combined with that obtained from the second transducer 5 relating to the amount and direction of rotation in the y direction, the processor 10 can calculate a desired change of location of the cursor on the display.

The person skilled in the art will appreciate that various modifications to the illustrated device could be made. Thus, for example, the directional detectors could be incorporated into the encoder discs.

Fig. 1

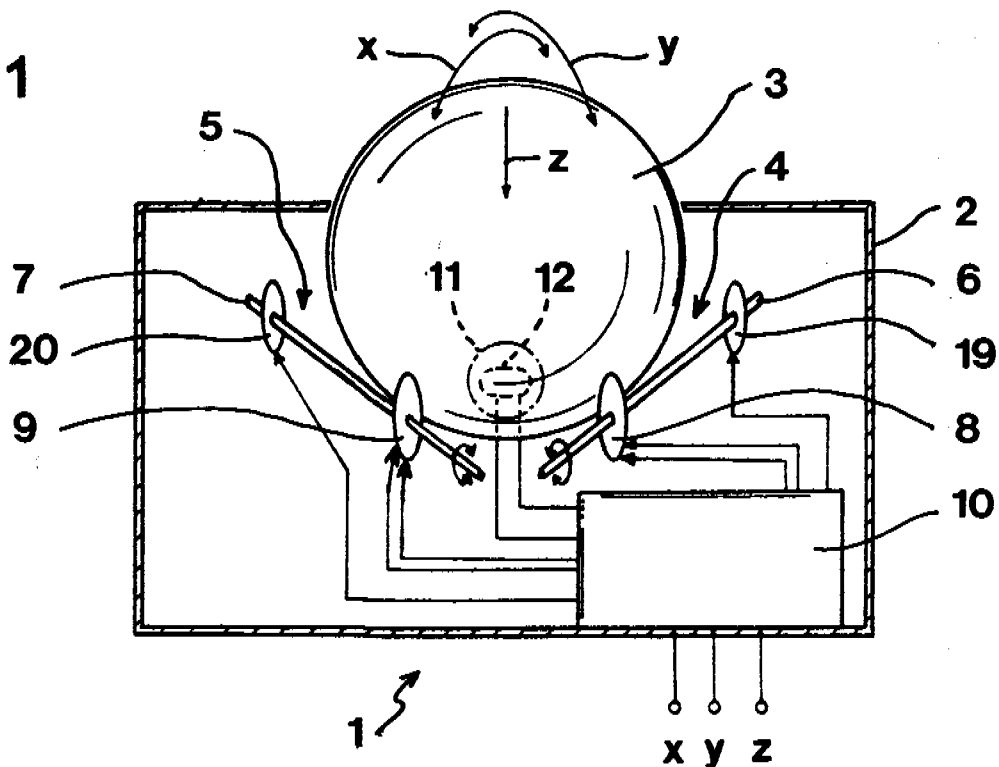
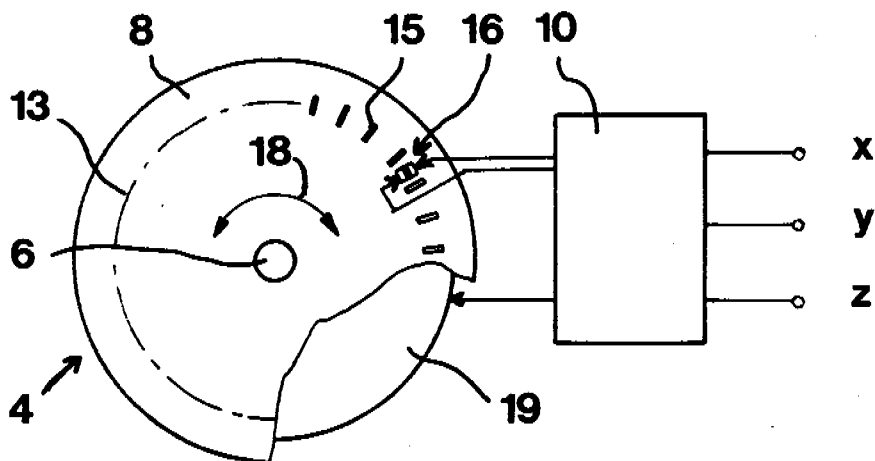

Fig. 2



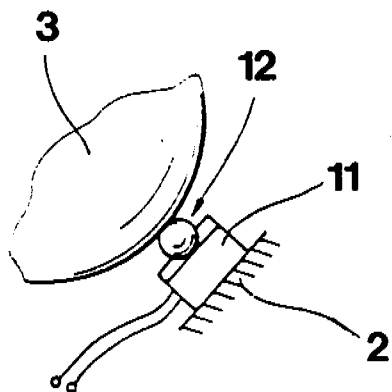

Fig. 3

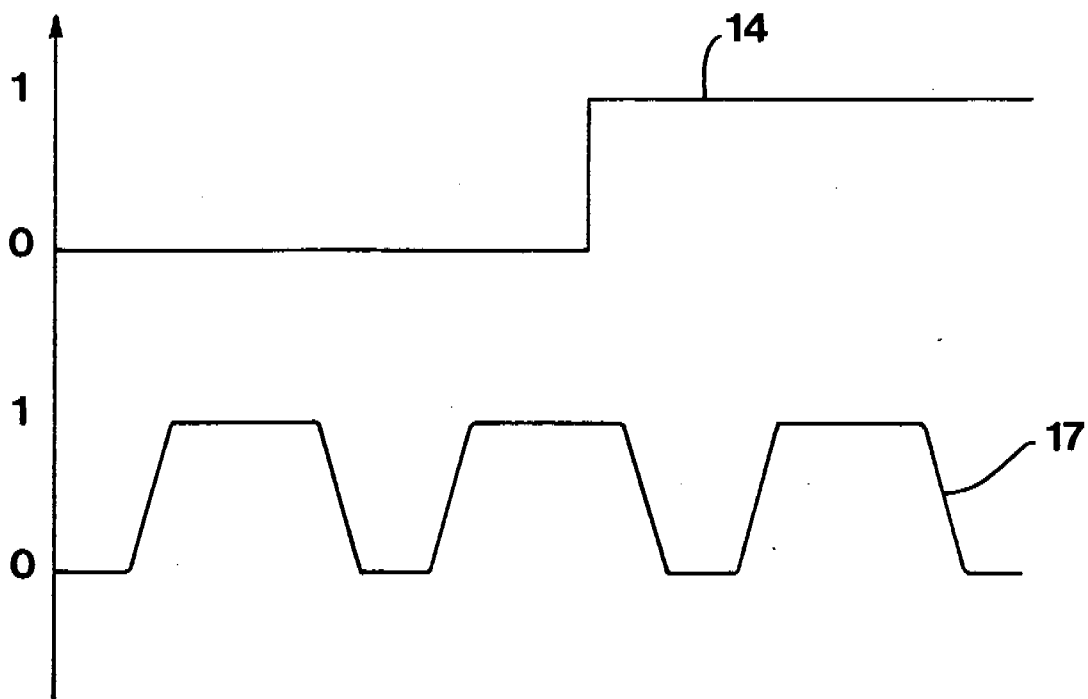

Fig. 4

DOCUMENT III (State of the Art)

This invention relates to an encoder disc for detecting the amount and direction of rotation of a shaft, for example in a computer mouse.

Encoder discs are well known and typically have a series of either teeth or slots or cut-outs arranged circumferentially around the encoder disc which serve to alternately permit or prevent the transmission of a light beam during rotation of the encoder disc.

A problem with existing encoder discs is that they only provide information regarding the amount of rotation and not about the direction of rotation. For this reason, it is generally necessary to provide in addition an arrangement for indicating the direction of the detected rotational movement. Such arrangements are well known and can take the form of a clutch or pawl device which produces a signal which varies according to the direction of rotation. Such known arrangements are, however, complicated and comparatively unreliable.

An object of the present invention is to provide a modified encoder disc which produces a signal or signals which not only contain information regarding the amount of rotation, but also the direction of rotation of the shaft.

This object is achieved by providing the encoder disc with teeth or slots of varying size, so that the signal generated by the interruption of the light beam contains pulses of differing lengths. In this way, the order in which these pulses are produced provides an indication of the direction of rotation of the shaft.

In the accompanying drawings:-

Figure 1 shows a part of the circumference of a first encoder disc according to the invention; and

Figure 2 shows a part of the circumference of a second encoder disc according to the invention.

As shown in Figure 1, an encoder disc 10 comprises a plurality of slots 11 all having the same width around its entire circumference. During rotation of the encoder disc, during the period when a slot 11 is aligned with a photo-emitter 12, as shown in the drawing, a pulse of light is transmitted

to a photo-detector (not shown). Between the slots 11 are provided teeth 13,14,15 of increasing width, the teeth 15 being wider than teeth 14 which in turn are wider than the teeth 13. The series of teeth in the order 13,14,15 is repeated around the entire circumference of the encoder disc. In this way, as the encoder disc rotates clockwise in the direction of the arrow 16, the intervals in which no light is transmitted to the photo-detector will occur in the order: long, medium, short. When the encoder disc rotates in the opposite direction, the intervals between the pulses will occur in the opposite sequence: short, medium, long.

The encoder disc 20 of Figure 2 is similar to that of Figure 1, except that the teeth 21 are of the same size and the slots 23,24,25 between the teeth are of varying widths. In this way it is the pulse width rather than the interval between the pulses which repetitively varies in the generated sequence of pulses.

Other embodiments of the invention may be envisaged having both varying tooth width and varying slot width.

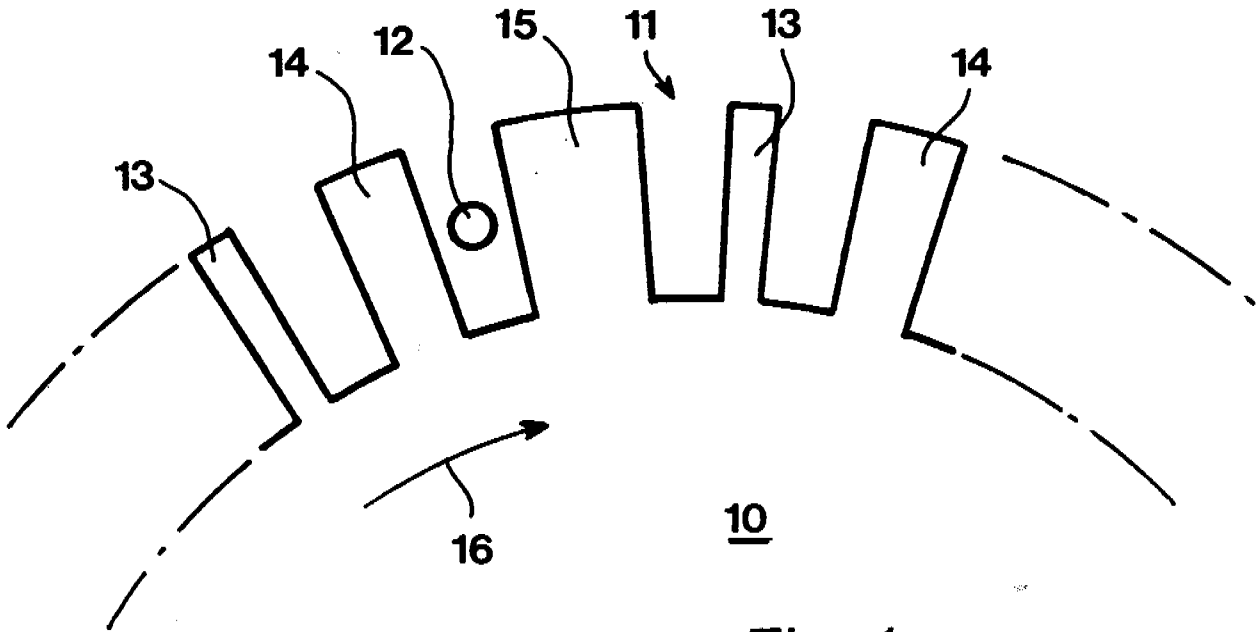

Fig. 1

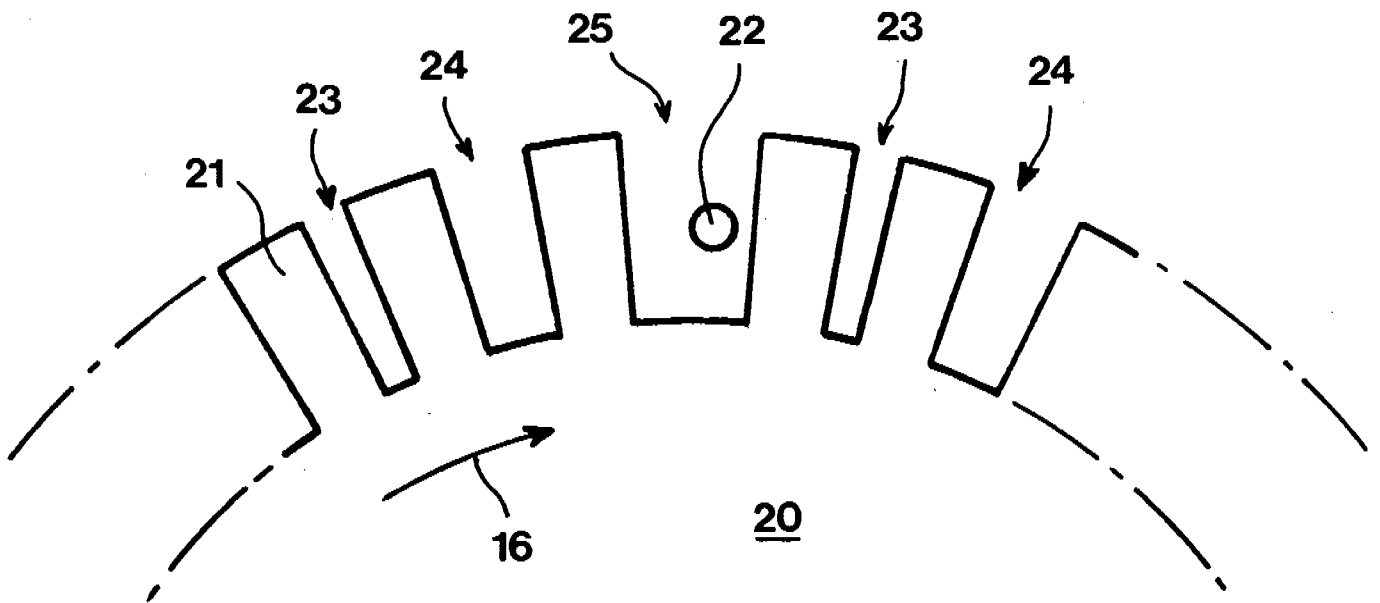

Fig. 2