

EUROPEAN QUALIFYING EXAMINATION 1992

PAPER B ELECTRICITY / MECHANICS

This paper comprises:

- Instructions to Candidates 92/B(E/M)/e/1
- Description of the Application 92/B(E/M)/e/2-10
- Claims 92/B(E/M)/e/11-12
- Drawings of the Application 92/B(E/M)/e/13-14
- Communication 92/B(E/M)/e/15-17
- Document I (State of the Art) 92/B(E/M)/e/18-19
- Drawings of Document I (State of the Art) 92/B(E/M)/e/20
- Document II (State of the Art) 92/B(E/M)/e/21-22
- Drawings of Document II (State of the Art) 92/B(E/M)/e/23-24

INSTRUCTIONS TO CANDIDATES

In this paper, you should assume that a European patent application for all the Contracting States comprising the appended documents* has been filed and that the European Patent Office has issued the annexed official communication.

You should accept the facts given in the paper and base your answers upon such facts. Whether and to what extent these facts are used is your responsibility.

You should not use any special knowledge you may have of the subject-matter of the invention, but are to assume that the prior art given is in fact exhaustive.

Your task is now to draft a full response to the official communication. The response should be a letter to the EPO, accompanied, if appropriate, by an amended set of claims. No amendments to the description should, however, be made, even if such amendments would be appropriate.

The claims should afford the maximum protection while meeting the requirements of the Convention. In your letter of response you should at least set out your arguments in support of the patentability of the independent claim(s).

If your response includes a proposal to make any part of the application the subject of divisional application(s), you should suggest a text for at least the independent claim(s) thereof and also include your arguments in support of the patentability of such claim(s).

In addition to your elaborated solution, you may - but this is not mandatory - give, on a separate sheet of paper, the reasons for your choice of solution, for example, why you selected a particular form of claim, a particular feature for an independent claim, a particular piece of prior art as starting point or why you rejected or preferred some piece of prior art. Any such statement should however be brief.

It is assumed that you have studied the examination paper in the language in which you have given your answer. If this is not so, please indicate on the front page of your answer in which language you have studied the examination paper. This always applies to candidates who - after having filed such a request when enrolling for the examination - give their answer in a language other than German, English or French.

*These documents do not necessarily constitute the only or best solution to the task set in Paper A (Electricity/Mechanics).

Description of the Application

The invention relates to electrical lighting fittings comprising a support structure to be suspended, for example from the ceiling of a room, such that an axis of suspension thereof extends in a vertical direction and at least one arm for carrying an electrical lamp, the or each arm being releasably mountable to the support structure. The invention relates in particular to chandeliers.

A known problem with chandeliers is that they occupy a lot of space when assembled, which makes their packaging, storing and shipment in the assembled condition expensive. To solve this problem, chandeliers with arms releasably (i.e. removably) mountable to the support structure thereof have been proposed in document I. This makes it possible to pack the chandeliers in a disassembled condition and thereby to reduce the storage and shipping costs. Such chandeliers are assembled by first suspending the support structure from the ceiling of the room and thereafter mounting the arms on the already suspended support structure. Since the arms are releasably mountable on the support structure, it is even possible to remove them when the chandelier is in place, thereby facilitating cleaning of the chandelier.

The chandeliers of document I have a support structure including first electrical connector means for cooperating with second electrical connector means provided on each of the arms. The first electrical connector means are so disposed on the support structure that, when the support structure is suspended, the second electrical connector means of an arm have to be inserted vertically. This is quite difficult because the first electrical connector means are not readily accessible to the person mounting the arms.

The object of the invention is to improve the known electrical lighting fittings such that it is easier to mount the arms to the support structure.

According to the invention this object is achieved in that the first and second electrical connector means are arranged for mutual insertion in a direction substantially perpendicular to the suspension axis of the support structure.

5 Thus, with the lighting fitting of the invention, when the support structure is suspended electrical connection between an arm and the support structure is established by horizontal insertion. This horizontal insertion is much easier to execute than the vertical
10 insertion required with the prior art.

The mutual engagement of the first and second electrical connector means provides some mechanical support for the arms. It is however advantageous to further provide the support structure and the or
15 each arm with mutually cooperating mechanical support means.

The mechanical support means can comprise a support member forming part of the support structure and displaced axially with respect to the first electrical connector means, the support member engaging
20 the or each arm.

Advantageously the support member comprises a wall extending parallel to the suspension axis and having at least one notch formed therein, the or each arm having a hook for cooperation with
25 a notch of the support member. With such mechanical support means the hook of an arm is first engaged with the support member and the electrical connection is established thereafter.

By contrast, mounting an arm is a much more difficult task in the
30 case of the prior art chandelier shown in Figure 1 of document I. This prior art chandelier has arms which are releasably attached to the support structure at two vertically displaced positions. Each of the arms of this known chandelier is provided with two hooks which engage respective notches formed in the vertical walls of two
35

vertically displaced support members of the support structure
mount such an arm it is necessary to lower the arm vertically so
that both hooks simultaneously engage the respective support
members while the electrical connector means of the arm are
5 inserted into the corresponding electrical connector means of the
support structure.

Particularly in the case of a lighter lighting fitting without an
upper support member it is desirable that the mechanical support
10 means releasably lock the or each arm in place. For this purpose
the mechanical support means can include a protrusion on the
support structure and a recess on the or each arm, the protrusion
being resiliently urged into the recess.

15 To enable the insertion in a direction substantially perpendicular
to the suspension axis of the support structure, the first elect-
rical connector means may comprise first and second electrically
conductive elements each extending perpendicularly to the suspen-
sion axis. In this case the second electrical connector means on
20 the or each arm comprise first and second contact pins each
cooperating with a respective one of said conductive elements.

An insulating spacer can be arranged between the conductive ele-
ments to separate and insulate them. This spacer can be made of a
25 resilient material.

A connector arrangement which is particularly simple to manufacture
can be obtained by providing that each contact pin of the or each
arm is inserted between the insulating spacer and one of the
30 conductive elements.

To facilitate the mutual insertion of the first and second elect-
rical connector means, the first electrical connector means can be
contained within a housing having at least one opening which
35 defines an insertion position for an arm.

Embodiments of the invention are described hereinafter with reference to the appended drawings, in which:

Figure 1 is an elevation view of a chandelier, shown partially in 5 section, the chandelier having upper and lower support members;

Figure 2 is an exploded perspective view of a connector arrangement of the chandelier of Figure 1;

10 Figure 3 is a partial cross-section of the connector arrangement of Figure 2; and

Figure 4 is a partial cross-section of a connector arrangement used in a lighter chandelier without the upper support member.

15

The chandelier, which is partially shown in Figure 1, includes an elongate rigid central support structure 1 and six arms 2, each of which is removably supported at two positions on the central support structure. In the assembled condition of the chandelier the 20 support structure 1 is suspended vertically from the ceiling of a room and each arm 2, only one of which is shown in Figure 1, occupies a vertical plane extending radially from the suspension axis 11 of the support structure.

25 The support structure 1 comprises an upper support member 12, a rigid stem 13 and a lower support member 14, the lower support member 14 also serving as electrical connector means. The upper support member 12 has a cylindrical outer wall 15 in whose upper edge six notches 16 are formed. The lower support member 14 has a 30 cylindrical wall 17 in which are formed six openings 18. Each notch 16 is vertically aligned above one of the openings 18. Two insulated electric supply wires 19 extend through the stem 13.

35

As shown in Figure 1 each arm 2 carries a lamp 21. In its lower portion 2a the arm 2 includes an electric connector plug 22 comprising two parallel flat metallic contact pins 23 which, when the arm is mounted on the support structure, extend horizontally towards the axis 11 of the support structure. The contact pins 23 are connected to the lamp 21 by insulated conductors not shown in Figure 1.

In its upper portion 2b each arm 2 has a hook 24 which is adapted to engage one of the notches 16. The hook 24 is provided on both sides with a vertically extending slot thereby forming a neck 25 of reduced cross-section. The neck 25 is received within one of the notches and is sufficiently wide at its upper portion to accommodate comfortably the cylindrical wall 15 of the upper support member. The neck 25 widens further towards its lower end so that, when the hook 24 is received in one of the notches 16, the arm 2 may be pivoted slightly about the hook in a vertical plane.

To mount an arm the hook 24 is first engaged with a notch 16 and then the arm 2 is pivoted towards the support structure 1 to insert the connector plug 22 in a substantially horizontal direction into the corresponding opening 18. In this way it is easy to attach an arm 2 to the support structure 1.

Figures 2 and 3 illustrate the internal construction of the lower support member 14, which includes the electrical connector means for receiving the connector plugs 22 of the arms 2.

The connector means include two identical electrically conductive plates 30, 31, which are preferably made of a copper alloy. The plates 30, 31 are separated by an insulating spacer 32, made of a resilient material, having a generally cylindrical configuration. The axis of the spacer 32 coincides substantially with the suspension axis 11 of the support structure 1.

35

The spacer 32 is formed with a peripheral rim 33, 34 on each upper and lower surfaces. Pairs of radially extending recesses are formed in the rims 33, 34 and the upper and lower surfaces of the spacer 32 for receiving the contact pins 23 of respective
5 plugs 22.

The spacer has an axial central opening. A locating slot 36 is formed in the periphery of the spacer 32 about midway between two adjacent pairs of recesses 35. A locating and access slot 37 formed
10 opposite the slot 36 communicates with the central opening.

The plate 30, which is located at the upper surface of the spacer 32, has a central opening and the outer circumferential edge of the plate 30 is bent slightly upwards. The plate 31 is located
15 at the lower surface of the spacer 32 with its bent edge directed downwards. The plate 31 also has a central opening.

The lower support member 14 comprises an upper housing portion 38 and a lower housing portion 39, both made of an insulating material. The housing portions 38, 39 enclose the spacer 32 and the
20 plates 30, 31.

As best seen on Fig. 2 the upper housing portion 38 comprises a downwardly extending pedestal 40 with a circumferential groove 41. Beyond the groove 41 the circumferential edge of the pedestal 40 is
25 inclined to fit within the peripheral rim 33 of the spacer 32. In the inclined edge of the pedestal 40 there are formed a pair of diametrically opposed positioning notches 42.

30

35

The lower housing portion 39 includes a circular base integrated with the circumferential cylindrical wall 17 in which are formed the openings 18 of the lower support member 14. In the center of the lower housing portion 39, on its upper side, there is formed a raised pedestal 43 having a circumferential groove 44 similar to the pedestal 40 and the groove 41 of the upper housing portion 38. A pair of diametrically opposed walls 45 are provided in the lower housing portion 39, the walls 45 being located midway between adjacent openings 18 and extending in a radial direction.

10
During the assembly of the lower support member 14 the upper housing portion 38 is secured to the lower end of the stem 13 by a nut 46. After the supply wires 19 have been soldered to the plates 30 and 31, the plates 30, 31 are located on the upper and lower surfaces respectively of the spacer 32. The wire for the plate 31 is inserted into the central opening of the spacer 32 using the access slot 37. The slots 36, 37 of the spacer 32 receive the opposed walls 45 to locate the spacer 32 and prevent rotation thereof. The positioning notches 42 of the upper housing portion 38 engage with the opposed walls 45. Screws 47 pass through holes in the notches 42 into the opposed walls 45 to fasten the lower housing portion 39 to the upper housing portion 38.

As shown in Figure 3, in the assembled condition of the lower support member 14, the upturned edge of the plate 30 extends freely into the groove 41. In similar fashion the downturned edge of the plate 31 extends freely into the groove 44. As the plug 22 of an arm 2 is inserted into one of the openings 18, the flat contact pins 23 enter a pair of recesses 35 in the insulating spacer 32 forcing the plates 30, 31 slightly apart. With the plug fully inserted, the plates 30, 31 are forced into tight engagement with the pedestals 40, 43 respectively. A substantial length of each contact pin 23 is then in contact with the surface of a plate and a slight vertical space appears between each plate 30, 31 and the insulating spacer 32 as shown in Fig. 3.

The floating relationship of the plates 30, 31 to the spacer 32 insures smooth making and breaking of electrical contact, and also solves a problem of manufacturing tolerances which might otherwise exist. By the use of a resilient spacer, improved electrical and mechanical connection is achieved.

In the chandelier illustrated with reference to Figures 1 to 3 both an upper support member 12 and a lower support member 14 are provided for supporting the arms 2. It is not always necessary however to provide two vertically displaced support members. With a lighter, less ornate arm the necessary support for the arm may be provided from a single support member which receives the connector plug of the arm for establishing the electrical connection. Figure 4 illustrates a support member for such a case.

The chandelier of Figure 4 includes a central support structure which is suspended along an axis 51 and has a single support member 52 to which a plurality of arms 60 are releasably attached. The arms 60 are lighter than the arms 2 of Fig. 1, including neither an upper portion (cf. 2b, Fig. 1) nor a hook (cf. 24, Fig. 1).

The support member 52 is substantially the same as the lower support member 14 shown in Figures 1 to 3. However the support member 52 is additionally provided with a locking member 53 which cooperates with the arms 60 to lock them securely in place. The locking member 53 is preferably formed of a resilient plastics or like material and has the configuration of a disc 54 with a downwardly protruding flange 55 and a handle 56 extending above the disc 54. The handle 56 has a central threaded opening therein and is screwed upon the rigid stem 57 which is threaded. Before inserting the arms 60 in the support member 52 the locking member 53 is screwed down onto the upper housing portion.

It will be seen in Figure 4 that each of the arms 60 has a transverse recess 61 formed in the inclined upper surface of a connecting plug 62. When an arm 60 is inserted into the support member 52, due to the resiliency of the locking member 53 the protruding flange 55 rides over the top of the plug 62 and latches in the recess 61. Thus, by resiliently urging the protruding flange 55 into the recesses 61, the arms 60 can be releasably secured in place. The arms 60 are precluded from twisting outwardly from the support member 52 by the action of the flange 55 on the upper part of each plug 62.

To release a single arm the locking member 53 can be urged locally upwards, for example using a screwdriver, to retract the flange 55 from the recess 61 of that arm. To release all of the arms the locking member 53 can be screwed upwards to simultaneously retract the flange 55 from the recesses 61 of all the arms 60.

It will be noted that in the chandelier of Figure 4 the contact pins 63 of the plug 62 provide both electrical connection and a certain amount of mechanical support for the arm 60. The bottom of each opening formed in the lower housing portion is moreover adapted to provide a support 58 under the plug 62.

Of course a locking member as described above can also be added to the lower support member 14 of the chandelier shown in Figure 1.

30

35

Claims

1. An electrical lighting fitting comprising a support structure (1; 50) to be suspended such that an axis (11; 51) of suspension thereof extends in a vertical direction and at least one arm (2; 60) for carrying an electrical lamp (21), the or each arm being releasably mountable to the support structure, the support structure (1; 50) including first electrical connector means (14; 52) for cooperating with second electrical connector means (22; 62) provided on the or each arm (2; 60), characterised in that the first and second electrical connector means (14, 22; 52, 62) are arranged for mutual insertion in a direction substantially perpendicular to the suspension axis (11; 51) of the support structure (1; 50).
2. A lighting fitting as defined in claim 1, characterised in that the support structure (1; 50) and the or each arm (2; 60) comprise mutually cooperating mechanical support means (12, 24; 53, 61).
3. A lighting fitting as defined in claim 2, characterised in that the mechanical support means include a protrusion (55) on the support structure (50) and a recess (61) on the or each arm (60), the protrusion being resiliently urged into the recess to releasably lock the arm in place.
4. A lighting fitting as defined in claim 2 or 3, characterised in that the mechanical support means comprise a support member (12) forming part of the support structure (1) and displaced axially with respect to the first electrical connector means (14), the support member (12) engaging the or each arm (2).

5. A lighting fitting as defined in claim 4, characterised in that the support member (12) comprises a wall (15) extending parallel to the suspension axis (11) and having at least one notch (16) formed therein, the or each arm (2) having a hook (24) for cooperation with a notch (16) of the support member (12).
6. A lighting fitting as defined in any one of claims 1 to 5, characterised in that the first electrical connector means (14; 52) comprise first and second electrically conductive elements (30, 31) each extending perpendicularly to the suspension axis (11; 51) and the second electrical connector means (22; 62) on the or each arm comprise first and second contact pins (23; 63) each cooperating with a respective one of said conductive elements (30, 31).
7. A lighting fitting as defined in claim 6, characterised in that the first electrical connector means (14; 52) includes an insulating spacer (32) arranged between the conductive elements (30, 31).
8. A lighting fitting as defined in claim 7, characterised in that each contact pin (23; 63) of the or each arm is inserted between the insulating spacer (32) and one of the conductive elements (30, 31).
9. A lighting fitting as defined in any one of claims 1 to 8, characterised in that the first electrical connector means (14; 52) are contained within a housing (38, 39) having at least one opening (18) which defines an insertion position for an arm.

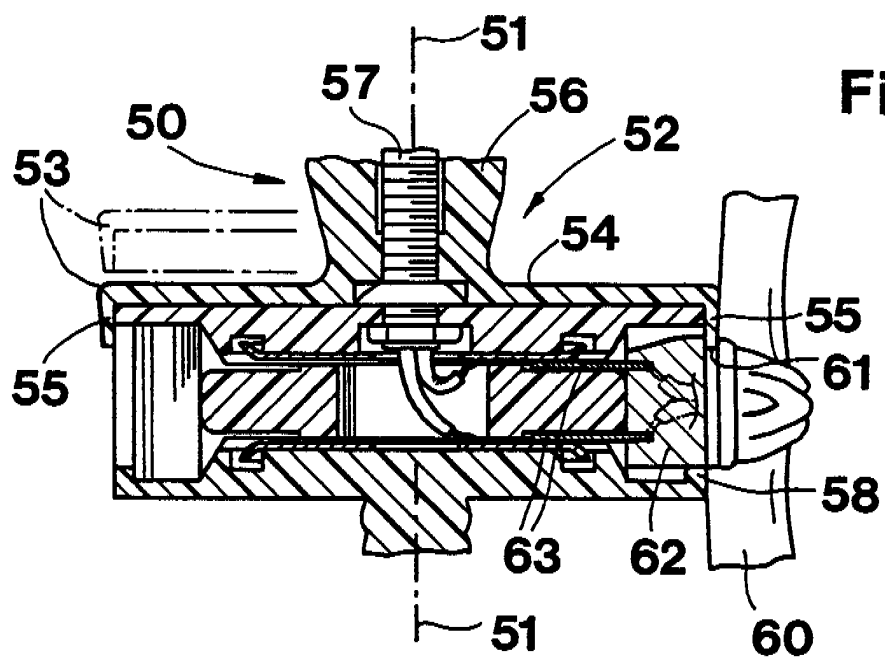
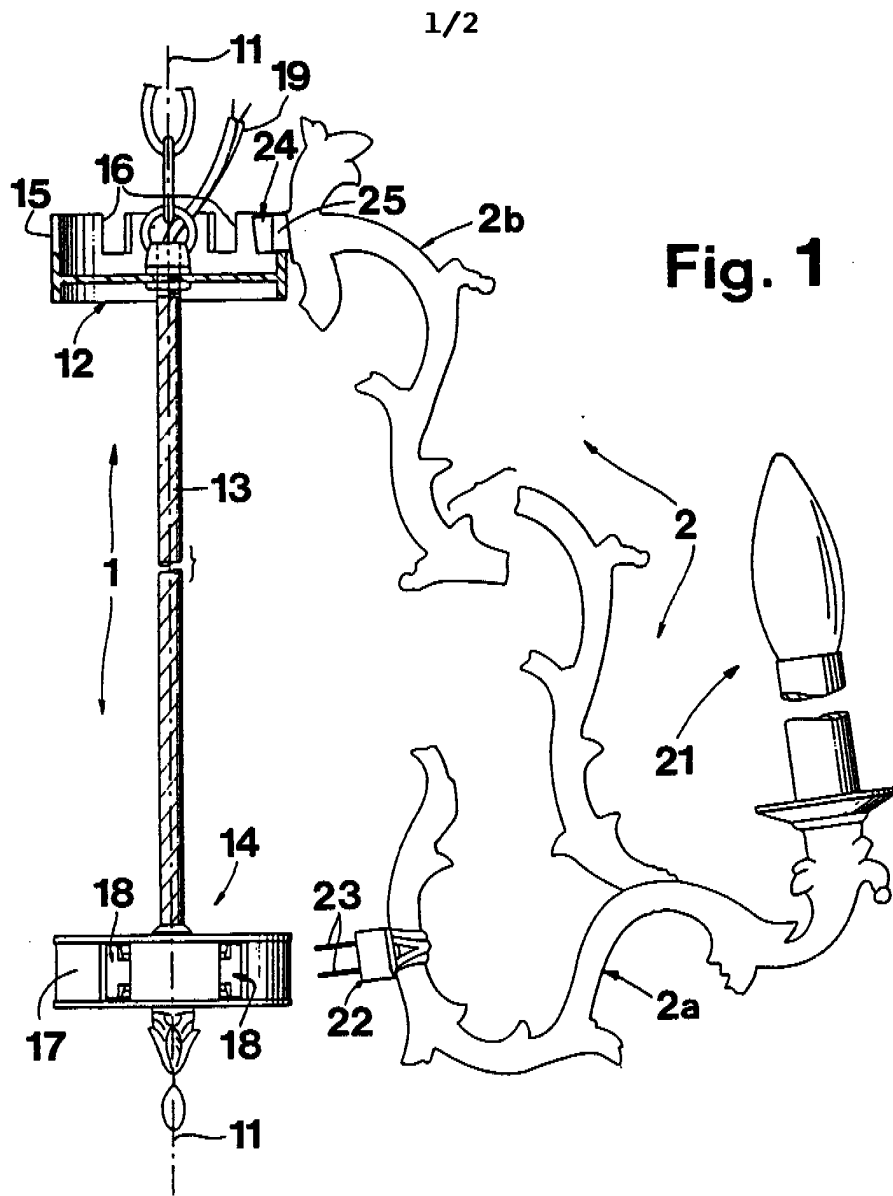

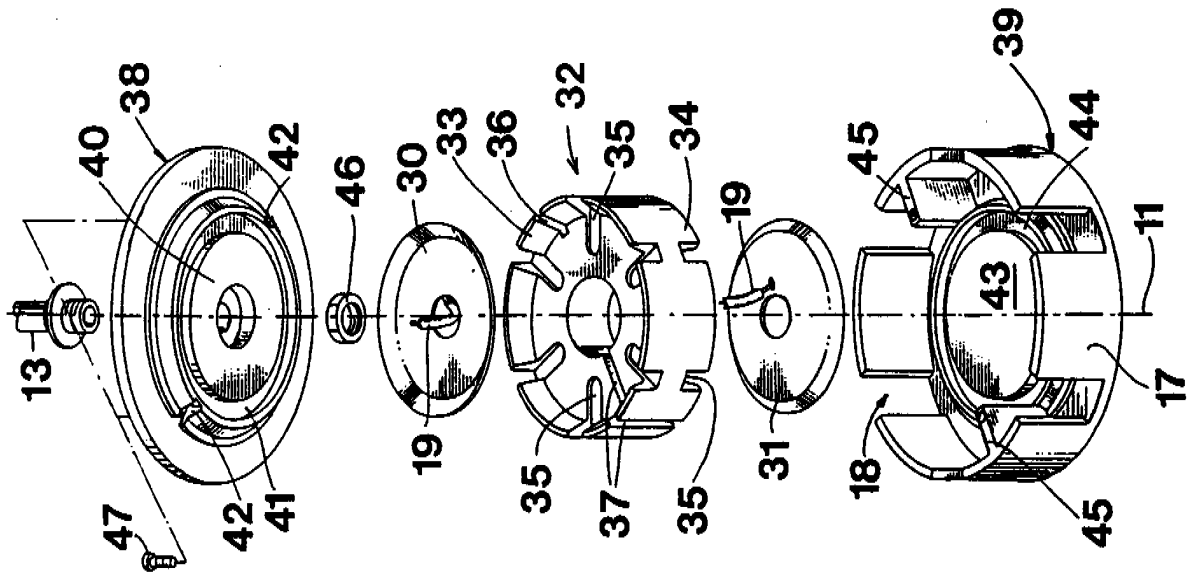

Fig. 2

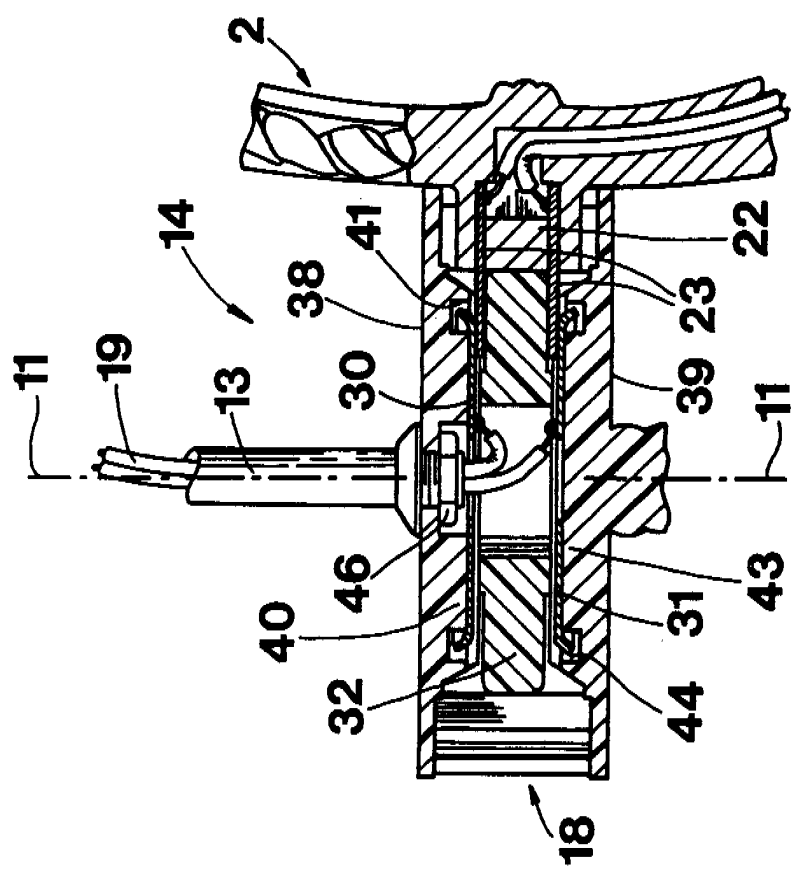

Fig. 3

Communication

Examination of the application has shown that it does not meet the requirements of the European Patent Convention for the reasons set out below.

1. The subject-matter of claim 1 lacks novelty with respect to document II, which is cited for the first time in this Communication.

Document II discloses a suspended electrical lighting fitting with a support structure (1) and a plurality of removable arms (5). The support structure and the arms include respective electrical connector means (2, 6) arranged for mutual insertion in a direction perpendicular to the suspension axis of the support structure.

2. The subject-matter of claim 2 also lacks novelty with respect to document II which discloses mechanical support means (recesses 28 of the support structure; pins 26, springs 27 and screws 21 of the arms) cooperating to support the arms on the support structure.
3. The features of claim 3 are an obvious inversion of the mechanical support means of document II in that the positions of the protrusion and the recess are interchanged.
4. The further features of claims 4 and 5 are disclosed in document I cited in the application. The lighting fitting of document I comprises a support structure (F) with a support member (10) displaced axially with respect to electrical connector means (30). The support member (10) comprises a wall (11) extending parallel to the suspension axis of the support structure and has notches (12) formed therein. Each arm (A) has a hook (61) cooperating with a notch (12) of the support member (10) to support the arm.

It is considered obvious for the skilled person to provide lighting fitting of the general type shown in Fig. 1 of document I with a horizontal electrical connection arrangement as disclosed in document II.

5. The subject-matter of each of claims 6 and 7 lacks novelty when dependent on claims 1 and 2 only, and lacks inventive step otherwise, as the further features specified in claims 6 and 7 are also disclosed in document II.

According to document II each of the arms (5) carries a pair of contact pins (22), each pin cooperating with one of two annular conductive elements (9, 13) of the support structure. The annular conductive elements (9, 13) extend perpendicularly to the suspension axis of the support structure (1) and are separated by an insulating spacer (11).

6. In view of document II the features specified in claim 8 do not add anything inventive to the subject-matter of claim 7.

According to document II each of the conductive elements (9, 13) has a groove. It is clearly apparent to the skilled person that it is sufficient to establish electrical contact with only one side of the groove. It is therefore obvious to the skilled person to omit one of the sides of the groove and thereby to arrive at the subject-matter of claim 8.

7. The subject-matter of claim 9 lacks an inventive step when dependent on one of claims 3, 4, 5 and 8 and lacks novelty otherwise as the further features specified in claim 9 are also disclosed in document II (note the openings (4) in the housing shown in Figure 2).

8. Consequently none of the claims are allowable owing to an absence of novelty or inventive step (Articles 52(1), 54 and 56 EPC).

If nevertheless you wish to continue with the application you are requested to file your observations and arguments, together with any amendments to the claims.

DOCUMENT I (State of the Art)

This document refers to modular chandeliers which can be packed, stored and transported in a space saving manner. They can quickly and easily be assembled and disassembled. In the drawings:

- 5 Fig. 1 is an elevation view of one embodiment of a modular chandelier;
Fig. 2 is a cross-sectional view taken along the line 2 - 2 of Fig. 1; and
Fig. 3 is an exploded perspective view showing the electrical
10 connection of one of the chandelier arms.

The chandelier shown in Fig. 1 includes a rigid central frame F and three radially extending arms A (of which only one is shown). The central frame F includes an upper support 10, a rigid stem 20 and a
15 lower support 30. The upper support 10 has a cylindrical outer wall 11 in whose upper edge three notches 12 are formed. The lower support 30 has a cylindrical wall 31 which is generally identical to the wall 11 and in which three notches 32 are formed.

20 A supply cable 40 passes through the hollow stem 20 of the frame F into the interior of the lower support 30. Within the lower support there are electrical contacts which will be described later.

Each of the arms A carries a lamp 50. Each arm has an upper por-
25 tion 60 with a hook 61 and a lower portion 70 with a hook 71. Each hook has a vertically extending neck which is received in a corresponding notch 12, 32.

As can best be seen from Fig. 3 each arm A also has a pair of male
30 electrical contacts 75 extending downwardly from the lowermost end

of the hook 71. A cable 80 connects the contacts 75 to the
of the arm.

Fig. 2 shows that the lower support 30 includes three pairs of
5 female electrical contacts, the first pair being identified by
references B1 and B2. The three pairs of female contacts are
connected to the cable 40 so that each pair can supply electrical
current to a respective arm.

10 Each notch 32 in the wall 31 and the associated pair of female
contacts cooperate with the hook 71 and the male contacts 75 of an
arm, respectively. Each notch 12 in the wall 11 receives a respec-
tive upper hook 61.

15 The assembly of the chandelier is made as follows. After having
suspended the central frame F from the ceiling, the first arm is
placed in a vertical plane such that the two hooks 61 and 71 are
disposed over the respective notches 12 and 32. Then the arm is
moved vertically downwards so that both hooks engage simultaneously
20 with their respective notches. This also results in the male
contacts 75 being inserted into the female contacts, thereby
completing the electrical connection to the lamp 50. The same
procedure is then followed for each of the remaining arms. A
cover 92 is then screwed over the lower support 30 by means of a
25 thread on the stem 20 in order to prevent dust collecting in the
lower support.

In an alternative embodiment which has lighter arms comprising the
lower portion 70 only of the arm A, only the lower support is
30 provided, the upper support being omitted.

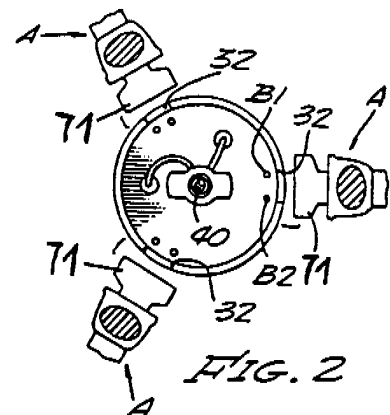
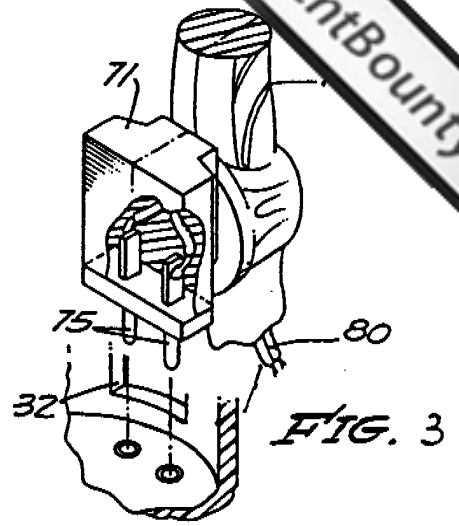
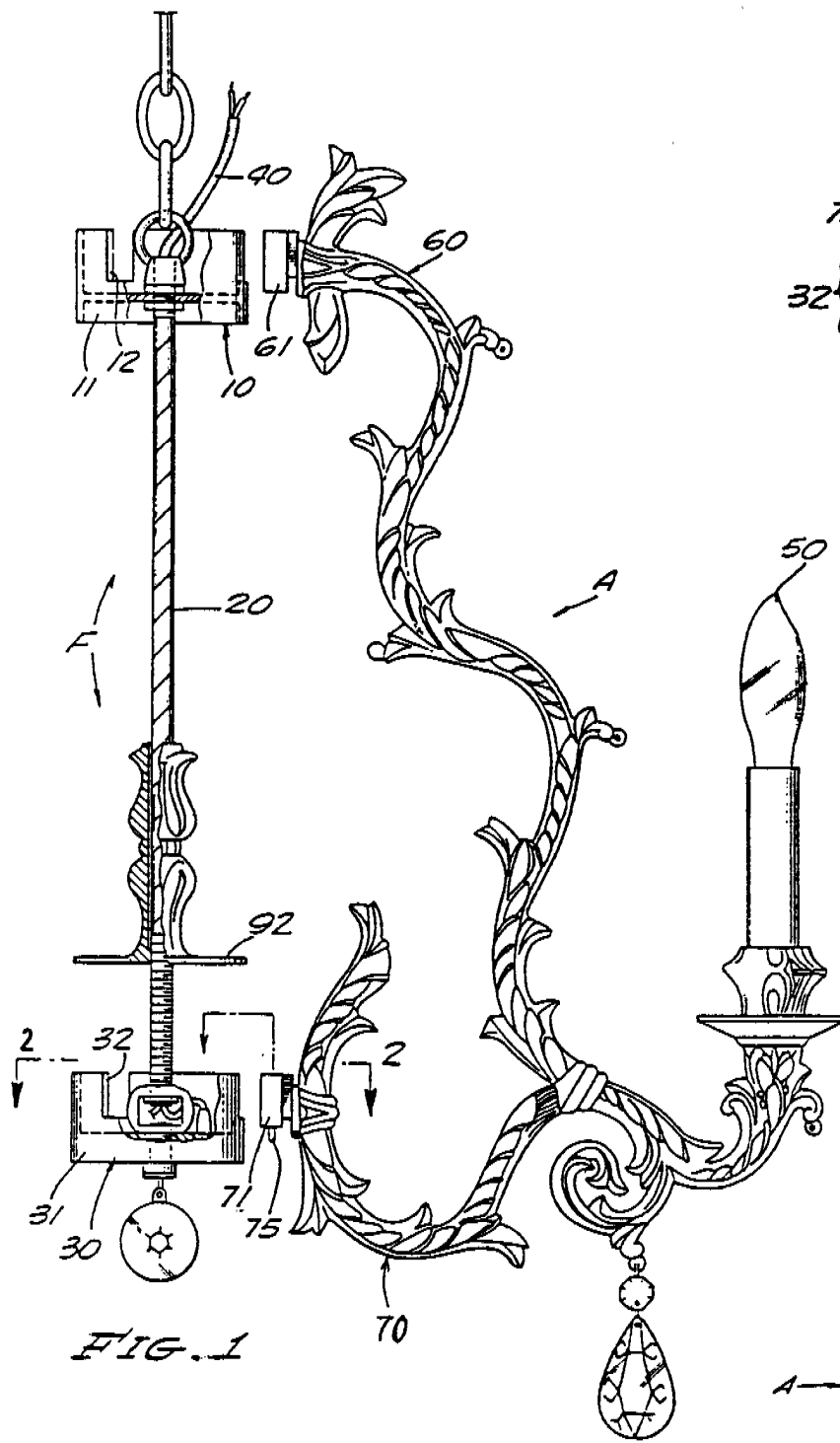

DOCUMENT II (State of the Art)

The invention relates to a chandelier having a plurality of discrete arms each of which carries an electric lamp at one of its ends.

5 One embodiment of the invention is illustrated in the drawings in which:

- Fig. 1 is a perspective view of the chandelier;
- Fig. 2 is an exploded perspective view of a carrying element;
- 10 Fig. 3 is a partial vertical cross-section through the carrying element, one chandelier arm being inserted therein; and
- Figs. 4 and 5 are partial vertical cross-sections of a plug associated with an arm, whereby in Fig. 5 the plug is inserted into the carrying element.

15 The chandelier comprises a body 1, the lower part of which is provided with a cylindrical carrying element 2 which has along its outer wall 3 a series of notches 4, one for each arm of the chandelier. Each arm 5 carries at one of its ends a plug 6, which
20 serves as an electrical connector as well as a mechanical locking means.

As can be seen from Figs. 2 and 3, the carrying element 2 includes:

- 25 - a first electrically insulating element 8 carrying at its periphery a first electrically conducting ring 9 with an outwardly facing groove 10,
- an electrically insulating intermediate disc 11 provided with a radial cut 12 for the supply wires 17, and
- 30 - a second electrically insulating element 15 carrying a second electrically conducting ring 13 with an outwardly facing groove 14, an upper portion of the element 15 forming a cover for the carrying element.

35 The whole assembly is secured by means of two nuts 29 to a threaded tube 7. The conducting rings 9 and 13 are sandwiched between the

insulating elements 8, 15 and the insulating disc 11 and are thereby electrically insulated with respect to each other. Each conducting ring is connected to a respective supply wire 17 which extends through the tube 7.

5

The bottom of each of the notches 4 is provided with two recesses 28 (Fig. 2) for cooperation with the plugs which will be described in the following by means of Figs. 4 and 5.

10 As can be seen from Fig. 4, which is a partial cross-section along the vertical plane of symmetry of an arm, the plug 6 consists of a support 19 carrying at one end a block 20 of electrically insulating material. In this block there are provided two contacts 22 which each consist of two blades with sloping faces at their outer
15 ends. The contacts are connected by means of two screws 23 to the ends 24 of an electric cable leading to the lamp on the arm.

Each plug 6 also comprises two mechanical locking elements, each of which is located on a respective side of the contacts 22. One of
20 these elements is shown in Fig. 5, which is a partial cross-section of a plug 6 when inserted in the carrying element 2. The cross-section of Fig. 5 lies in a vertical plane parallel to that of Fig. 4, but passing through one of the screws 21 which can be seen in Fig. 2. Each mechanical locking element comprises a pin 26, a
25 spring 27 and a screw 21 housed in a vertical bore in the block 20. Each pin cooperates with a respective recess 28 at the bottom of one of the notches 4.

As the chandelier described above is assembled, the arms 5 are
30 inserted into the carrying element 2. Thereby the two blades of each contact 22 are inserted into the respective grooves 10 and 14 of the conductor rings 9 and 13. When the final position is reached, the pins 26 lock into the respective recesses 28 in the carrying element. In this way both a good electrical contact and a
35 reliable mechanical connection between the arms and the carrying element is made.

1/2

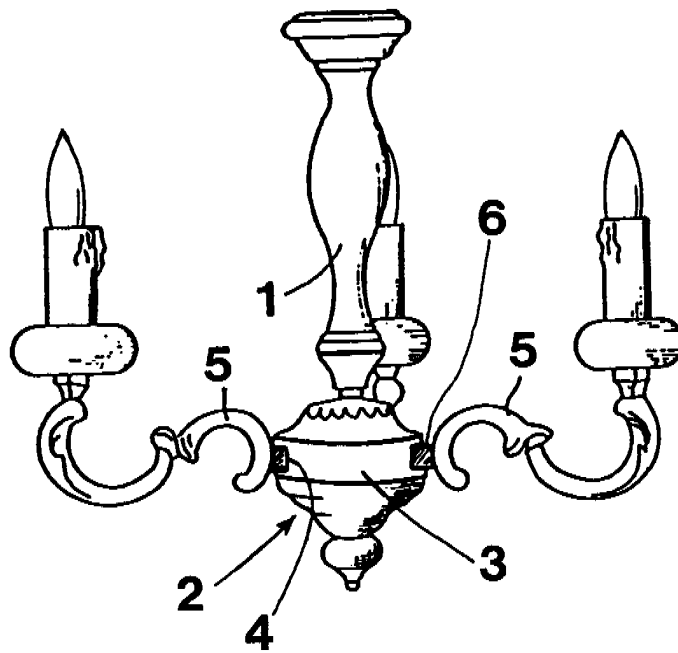

Fig. 1

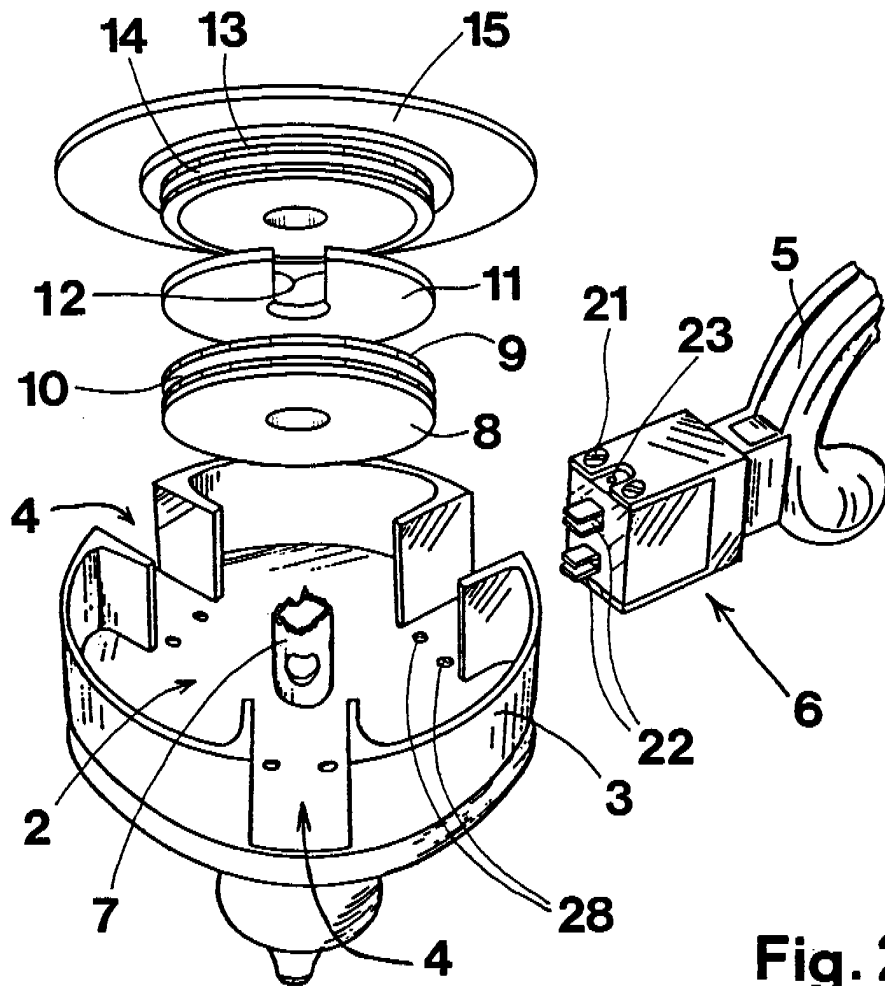

Fig. 2

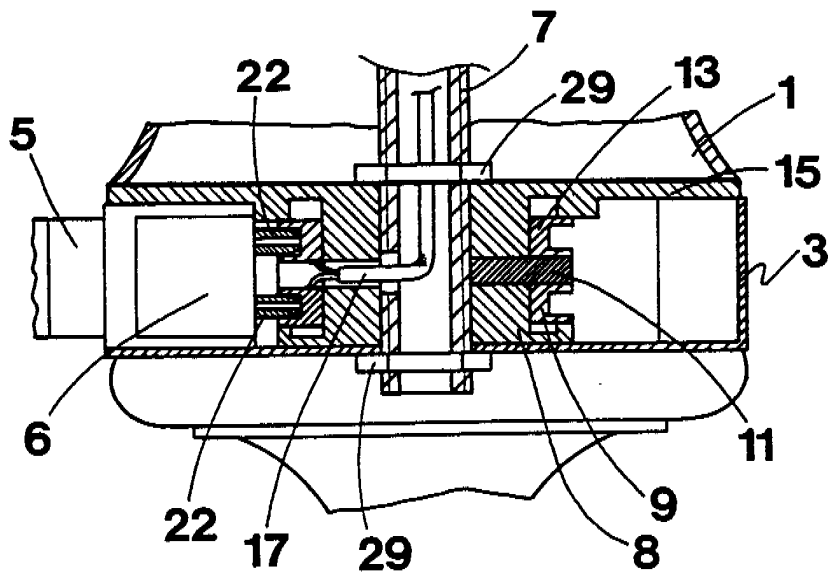

Fig. 3

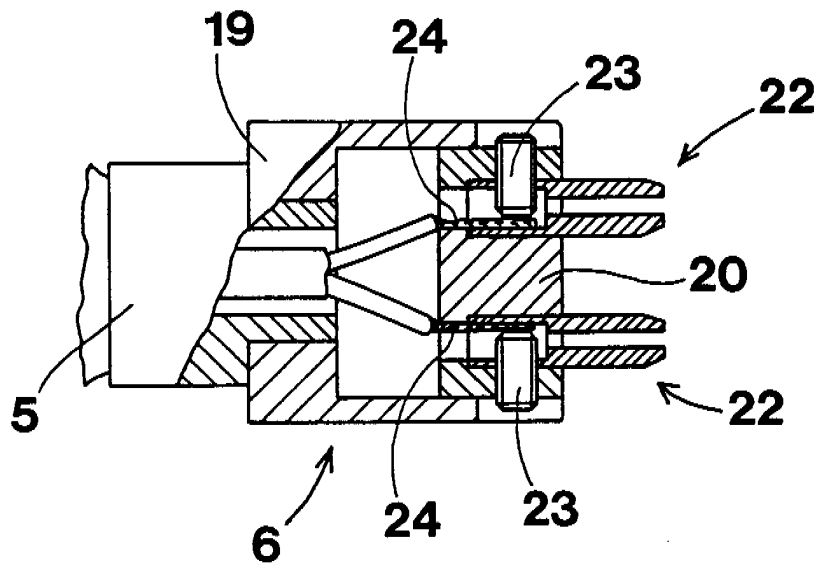

Fig. 4

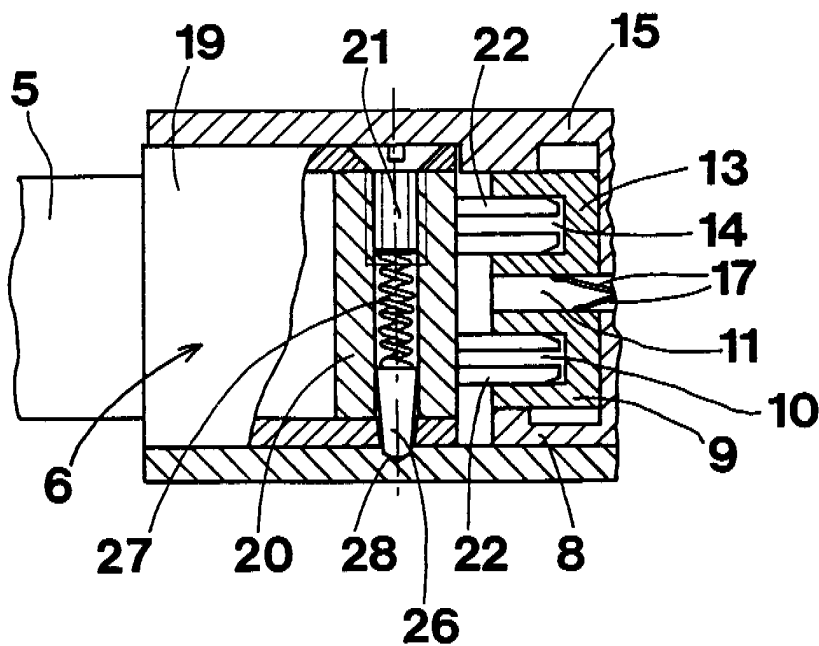

Fig. 5