

**EUROPEAN QUALIFYING EXAMINATION 1991**

**PAPER B  
ELECTRICITY / MECHANICS**

**This paper comprises:**

- |  |                   |
|--|-------------------|
| • Instructions to Candidates                 | 91/B(E/M)/e/1-2   |
| • Description of the Application             | 91/B(E/M)/e/3-11  |
| • Claims                                     | 91/B(E/M)/e/12-13 |
| • Drawings of the Application                | 91/B(E/M)/e/14-15 |
| • Communication                              | 91/B(E/M)/e/16-18 |
| • Text of Document I (State of the Art)      | 91/B(E/M)/e/19-20 |
| • Drawing of Document I (State of the Art)   | 91/B(E/M)/e/21    |
| • Text of Document II (State of the Art)     | 91/B(E/M)/e/22-23 |
| • Drawings of Document II (State of the Art) | 91/B(E/M)/e/24-25 |

## INSTRUCTIONS TO CANDIDATES

In this paper, you should assume that a European patent application comprising the appended documents\* has been filed and that the European Patent Office has communicated the annexed official letter.

You should accept the facts given in the paper and base your answers upon such facts. Whether and to what extent these facts are used is your responsibility.

You should not use any special knowledge you may have of the subject-matter of the invention, but are to assume that the prior art given is in fact exhaustive.

Your task is now to draft a full response to the official letter. The official letter may or may not necessitate amendment of the description or claims or both and may or may not require arguments, for example as to the relevance of the prior art. You should bear in mind, in drafting your response, that the claims should afford the maximum valid protection. The response should be a letter to the EPO, but no particular form is mandatory. Any amendments should be clearly stated as insertions or deletions in the response or set out in a separate document. In any case, the amendments proposed should be sufficient to meet the requirements of the Convention as to both claims and description.

---

\* These documents do not necessarily constitute the only or best solution to the task set in Paper A (Electricity/Mechanics).

If your response includes a proposal to make any part of an application the subject of a divisional application, you should suggest a text for at least the main claim of the divisional application and also indicate, where appropriate, your grounds for considering such claim to be acceptable. You need not however propose an introduction for any divisional application.

In addition to your elaborated solution, you may - but this is not mandatory - give, on a separate sheet of paper, the reasons for your choice of solution, for example, why you selected a particular form of claim, a particular feature for an independent claim, a particular piece of prior art as starting point or why you rejected or preferred some piece of prior art. Any such statement should however be brief.

It is assumed that you have studied the examination paper in the language in which you have given your answer. If this is not so, please indicate on the front page of your answer in which language you have studied the examination paper. This always applies to candidates who - after having filed such a request when enrolling for the examination - give their answer in a language other than German, English or French.

Description of the Application

Device for melting and dispensing thermoplastic material

The invention relates to devices for melting and dispensing thermoplastic material such as adhesives. In a preferred form, the invention relates to a hot melt glue gun.

5 Such a glue gun melts a solid adhesive which is supplied to it in the form of a rod. The molten adhesive or glue is then dispensed by applying pressure to the adhesive rod to advance the rod and force the molten glue out of the gun. A known problem with these hot-melt glue guns is that drooling occurs, i.e. the glue  
10 continues to come out when the pressure applied to the adhesive rod is released. To solve this problem the hot-melt glue gun described in Document I had already been developed. To prevent drooling in this device when the pressure on the solid rod of adhesive is released, the adhesive rod is pushed back by means of  
15 a spring, and the resulting reduced pressure in the melting chamber causes the molten glue to be sucked back. This principle has proved successful in overcoming the problem of drooling.

The invention concerns an improvement to this device designed to  
20 eliminate certain drawbacks that have emerged in its use.

In the known device only the forward portion of the spring is in the region of the heating device and therefore, at the beginning of the heating process, the rear portion of the spring is still  
25 embedded in solid adhesive and only the forward portion can be compressed. Consequently, at the start of the heating process the spring exerts an inadequate return force on the adhesive rod.

The object of the present improvement was therefore to create a similar gun for meltable adhesives with a return motion device that is fully effective from the outset.

5 This is achieved by the features of claim 1.

The known hot-melt glue gun has resistance heating with a thermostat to prevent a preset maximum temperature from being exceeded. This resistance heating is located directly on the  
10 melting chamber, where the adhesive must be sufficiently fluid. This arrangement does not enable the required operating temperature to be reached at the same time in all areas. This results in undesirable delays before the glue gun can function fully.

15

It has also been found that, when the rod is advanced too rapidly into the heated melting chamber, the temperature drops so far that a delay occurs before the adhesive once more comes up to its operating temperature. This leads to uneven liquefaction of the  
20 adhesive.

In the invention, the heating device was therefore also redesigned to make the hot melt glue gun ready for use more quickly and to avoid differences in the viscosity of the emerging  
25 adhesive.

For this purpose a PTC heating resistor is used.

This is a resistor with a positive temperature coefficient, this  
30 means that the resistance increases considerably with temperature, for example, linearly or according to an exponential law. Such a PTC heating resistor at constant supply voltage maintains a substantially constant operating temperature as a drop in temperature produces a higher current flow through the  
35 resistor and thus a higher heat production, and vice versa. Sintered material has proved suitable for the PTC heating resistors.

The PTC heating resistor extends a relatively large distance parallel to the longitudinal axis of the heating tube.

The PTC heating resistor can take the form of one or more PTC wires or one or more discrete PTC resistor elements.

The PTC wires can be linear and located on or in the body to be heated. Alternatively, the wires can be wound like a coil around the body.

10

A further improvement to the heating device which allows different operating temperatures to be obtained comprises several strings of series-connected PTC resistor elements connected in parallel in a heating cartridge with the individual parallel strings selectively connectable. When the resistor strings are in parallel, the total resistance of the heating cartridge is lower than the resistance of a single string, therefore, at a constant supply voltage, an increase occurs in the current supplied and thus in the heating cartridge output, which is proportional to the square of the current. In this way, different, self-stabilising operating temperatures can be achieved at a constant supply voltage, e.g. 220 volts, by selectively switching parallel PTC resistor strings. This enables adhesives with different melting points to be used in the same gun.

25

The heating device, and in particular the heating cartridge, can also be manufactured and sold separately from the glue gun.

.../...

Preferred features of the invention are set out in the dependent claims.

In the drawings:-

5

Figure 1 shows a side view of a hot-melt glue-gun;

Figures 2 and 3 show an axial section through the melting device, in a first and second operating state respectively;

10

Figure 4 shows an axial section through a heating cartridge;

Figures 5 and 6 each show a cross-section along the line A-A of Figure 4 with parallel resistor strings and a single resistor string respectively.

15

Figure 1 is a diagrammatic view of a hot-melt glue gun. In it a melting device 40 is held in place by two positioning rings 51 and 37 made of resilient heat-resistant material. The gun's plastic housing consists of two half-shells joined by screws (not shown).

20

The gun comprises a heating tube 10 (Figures 2 and 3), which is of a very good heat-conducting material, which is associated with a heating device which is described below. The heating tube has a through bore having a cylindrical portion 12 which houses a melting chamber 16 in an axially slideable manner. The melting chamber 16 is heated by the surrounding heating tube 10 until the thermoplastic adhesive inserted into the melting chamber 16 melts. The melting chamber has an inlet 17 through which the thermoplastic rod of adhesive 50 (Figure 1) is pressed, and an outlet 19 (Figures 2 and 3) from which the molten adhesive passes via the bore 13 of an intermediate piece 14 into a nozzle assembly 22 having an outlet end 20.

30



By means of its external thread 28 the intermediate piece 14 is screwed into an internal thread 27 provided at the melting chamber outlet 19, with the interposition of a heat-resistant metal seal 24. Thus the intermediate piece 14 is rigidly fixed to the melting chamber 16 and slides with it in the heating tube 10. The free end of the intermediate piece 14 is located in a cylindrical central bore 23 in the nozzle assembly 22. This bore 23 in the nozzle assembly has a diameter only slightly larger than the external diameter of the free end of the intermediate piece 14. The intermediate piece can slide inside the bore 23 in the nozzle assembly 22, there being provided an O-ring seal 25 of the heat resistant material therebetween.

Between the nozzle assembly 22 and the melting chamber 16, which is slideably mounted in the heating tube 10, is a coil spring 26 which forces the melting chamber 16 rearwardly away from the nozzle assembly 22 in the direction opposite to the feeding direction of the adhesive rod indicated by the arrow 31. A shoulder 21 in the heating tube 10 limits the rearward movement of the melting chamber 16. Thermal coupling between the melting chamber 16 and the heating tube 10 is achieved by means of a lubricant which is a good conductor of heat such as a graphite/silver/oil emulsion. The inside of the melting chamber 16 has axial heating fins 11. The cross-section of these fins increases in size towards the outlet 19, so that a larger area is available adjacent the outlet for heat transmission to the adhesive.

Figure 2 shows the melting device before the spring 26 is compressed by the insertion of a rod of adhesive, i.e. with the melting chamber in its rearward position of rest. If a rod is pressed into the melting chamber 16 through the inlet 17, the spring 26 is compressed and the melting chamber takes up the



forward position shown in Figure 3. As long as the rod continues to exert pressure on the melting chamber, the latter remains in this position.

5 The heating tube 10 has on its forward end an internal thread 47 into which the nozzle assembly 22 is screwed. The free internal diameter of this internal thread 47 is at least the same as or greater than the outer diameter of the melting chamber 16 and of the intermediate piece 14 attached thereto. If the nozzle  
10 assembly is unscrewed, the intermediate piece 14 along with the melting chamber 16 attached to it can be removed from the heating tube. This is a great advantage if a new adhesive is to be used which cannot be mixed with or has a considerably different melting point from the first one. In such cases the change of  
15 material can be effected quickly, cleanly and smoothly using a second melting chamber and intermediate piece.

The heating tube 10 has evenly distributed around its circumference three housings 39 for heating cartridges 45. Each  
20 of these housings has a bore running parallel to the axis of the heating tube. The heating cartridges, which are described in detail below, are inserted in the housings 39 in such a manner that a good heat transmission is provided between the cartridge and the heating tube.

25

Figure 4 shows a heating cartridge with at least one series-connected resistor string consisting of resistor elements R1, R2 and R3. The heating cartridge 45 has an electrically-insulating, heat-resilient, and preferably resilient sleeve 70. Inside the  
30 sleeve the elongated PTC resistor elements R1, R2 and R3 are received between respective pairs of thermally-conductive contact bodies 61, 71, 62, 72, 63 and 73. Leaf springs 81, 82 and 83 are provided between the resistor elements and contact bodies so as to provide a force fit of the whole arrangement in the sleeve.  
35 This heating device can therefore be assembled extremely easily.

The leaf springs produce not only a tight force fit inside the sleeve 70 but also constant contact pressure between the PTC resistor elements and the contact bodies even in the event of wide fluctuations in temperature, the leaf springs automatically  
5 compensating for dimensional changes in the individual elements and thus ensuring constant thermal resistance.

Even ageing of the material of the heating cartridge's individual elements has no detrimental effect on the thermal contact of the  
10 PTC resistor elements with the rest of the cartridge. If for example, the sleeve material becomes harder and less resilient, with the possible result that its interior becomes slightly enlarged, this is compensated by the leaf spring which is able to curve slightly. The sleeve advantageously consists of a mixture  
15 of silicon with one or more metal oxides.

Although the heating cartridge could in theory be designed in a number of different ways, it has proved particularly advantageous to give the sleeve interior a circular cross-section and to make  
20 the contact bodies more or less semi-circular in cross-section. The circular cross-section ensures that the arrangement consisting of the PTC resistor elements, the contact bodies and the leaf springs are compressed evenly from all sides and hence at the same time ensures uniformly distributed transmission of  
25 heat to the the housing 39 and the heating tube 10.

Various designs are also possible for the PTC resistor elements. They may, for example, be of square, oblong or semicircular cross-section, entailing appropriate variations in the design of  
30 the contact bodies and the leaf springs. In the embodiments considered here the PTC resistor elements are of oblong cross-section.

The heating cartridge has one or more strings of series-connected PTC resistor elements. Between each pair of adjacent resistor elements is a thermally and electrically insulating disc 66 whose external diameter corresponds approximately to the internal diameter of the sleeve 70 and which has a central bore 65 for electrical connection between the resistor elements.

Figure 5 depicts a cross-section through the heating cartridge 45 corresponding to the line A-A of Figure 4, with three resistor strings which can be connected in parallel. This enables different operating temperatures to be set with one and the same heating cartridge using an appropriate switching means. The contact bodies 61 and 71 have a more or less semicircular cross-section and, together with the respective PTC resistor elements R1a, R1b and R1c, of the three resistor strings, form a virtually circular cross-section.

For each of the three resistor strings a recess 76a, 76b and 76c is provided in the sleeve 70 for the respective return conductor 75. Between the contact body 61 and the corresponding oblong PTC resistor elements are inserted leaf springs 81a, 81b and 81c. The three resistor elements R1a, R1b, and R1c are made of different PTC materials with a different temperature-dependence. These resistor elements are electrically insulated from each other by insulating leaves 69. The resistor elements are thus identical within a single string, but differ from string to string.

Figure 6 is a cross-section through an alternative embodiment where instead of a number of resistor strings being operated in parallel connection the heating cartridge contains only a single resistor string R1', which allows only a single operating temperature at a constant supply voltage.

When the adhesive rod is introduced into the melting chamber it is in contact with the heating fins 11 and its forward portion begins to melt. To dispense the molten adhesive pressure is applied to the rear end of the adhesive rod by the user's thumb, 5 whereby the solid part of the advancing rod expels the molten adhesive from the nozzle assembly 22 in the manner of a piston. When the pressure on the rod is released, the return force of the spring 26 pushes the melting chamber 16 back into its position of rest where it contacts the shoulder 21. This rearward movement 10 of the melting chamber causes the molten adhesive to be sucked back from the region of the nozzle assembly thereby preventing drooling.

When the adhesive rod is advanced, a relatively cool portion of 15 the rod enters the rear part of the melting chamber 16 and causes a temperature drop therein. This temperature drop is transmitted firstly to that section of the heating cartridge 45 in which the resistor element R3 is located. This considerably reduces the resistor element's resistance value and at constant supply 20 voltage there is a consequent increase in the current taken by the resistor string. This increase in current causes an increase in the heat production of the resistor string. As a consequence the heat production is adapted to the speed of advancement of the adhesive rod and thereby the amount of adhesive dispensed.

Claims

1. A device for melting and dispensing thermoplastic material, comprising a heating means (45), a melting chamber (16) with an inlet (17) for the unmelted material which is fed in under pressure and an outlet (19) for the molten material, and a resilient element (26) which exerts a return force on the material against the feeding direction, characterised in that the melting chamber (16) is slideably arranged in the device, and that the return force of the resilient element (26) acts on the melting chamber.
2. A device as claimed in claim 1, characterised in that the melting chamber (16) can slide axially in a heating tube (10) on which the heating means (45) is provided, and that the melting chamber is thermally coupled with the heating tube.
3. A device as claimed in claim 1 or 2, characterised in that the melting chamber (16) is fitted with heating fins (11) which are arranged lengthwise and protrude into the chamber and whose heat transmission surface increases continuously towards the outlet (19).
4. A device as claimed in any one of claims 1 to 3, characterised in that the resilient element is a coil spring (26).
5. A device as claimed in any one of claims 1 to 4, characterised in that the heating means is electric and has at least one PTC resistor element.



6. A device as claimed in claim 5, characterised in that the heating means has a series connection of PTC resistor elements (R1, R2, R3) which are arranged along the length of the melting chamber (16).
7. A device as claimed in claim 6, characterised in that a number of series-connections are selectively connectable in parallel.
8. A device as claimed in any one of claims 5 to 7, characterised in that the PTC resistor elements are integrated in a heating cartridge (45) which has an electrically insulating, heat-resistant and preferably resilient sleeve (70), and the PTC resistor elements are arranged in a force fit between at least two contact bodies (61, 71; 62, 72; 63, 73) to provide thermal coupling, leaf springs (81, 82, 83) being provided between the PTC resistor elements and the contact bodies.
9. A hot-melt glue gun having a device as claimed in any one of the preceding claims.

1/2

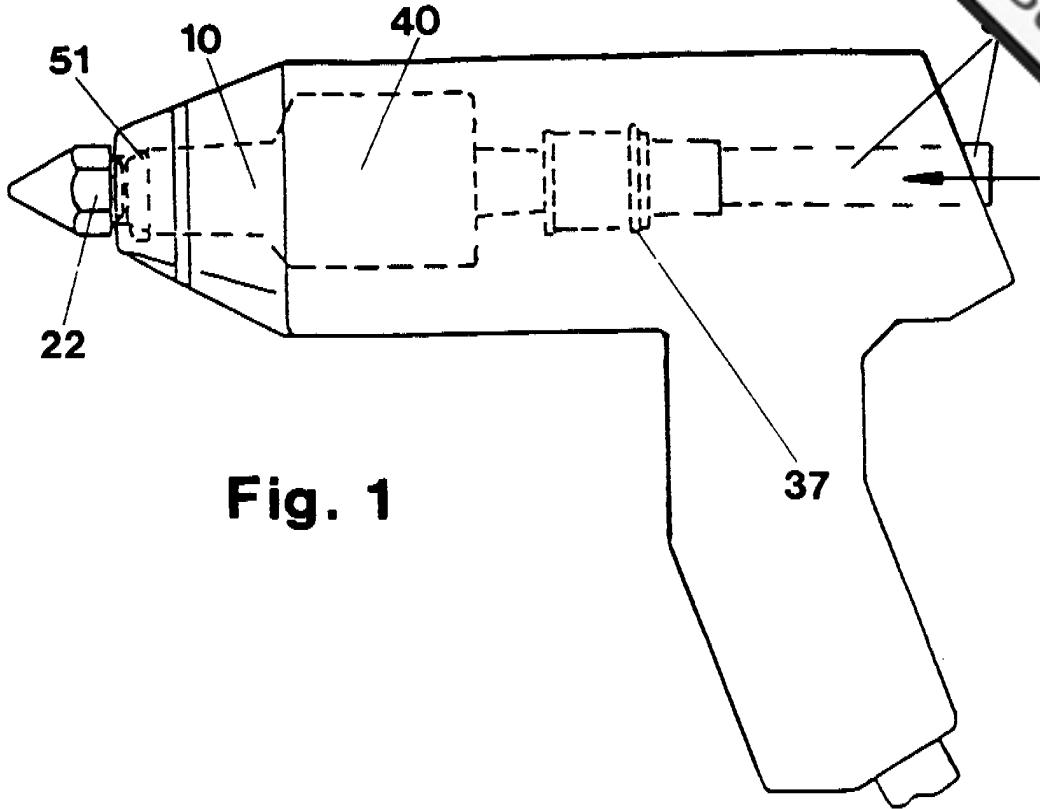

**Fig. 1**

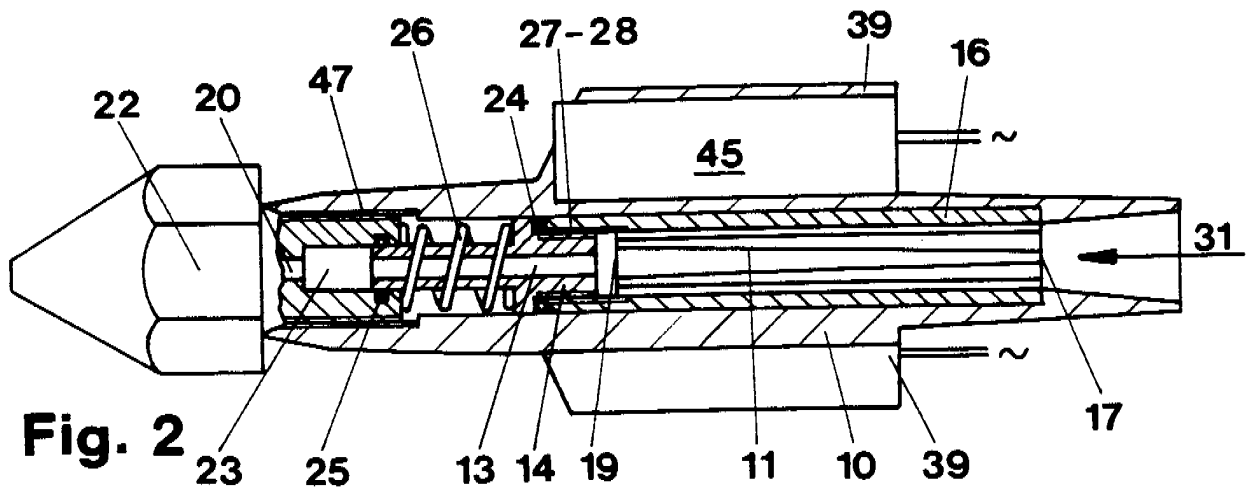

**Fig. 2**

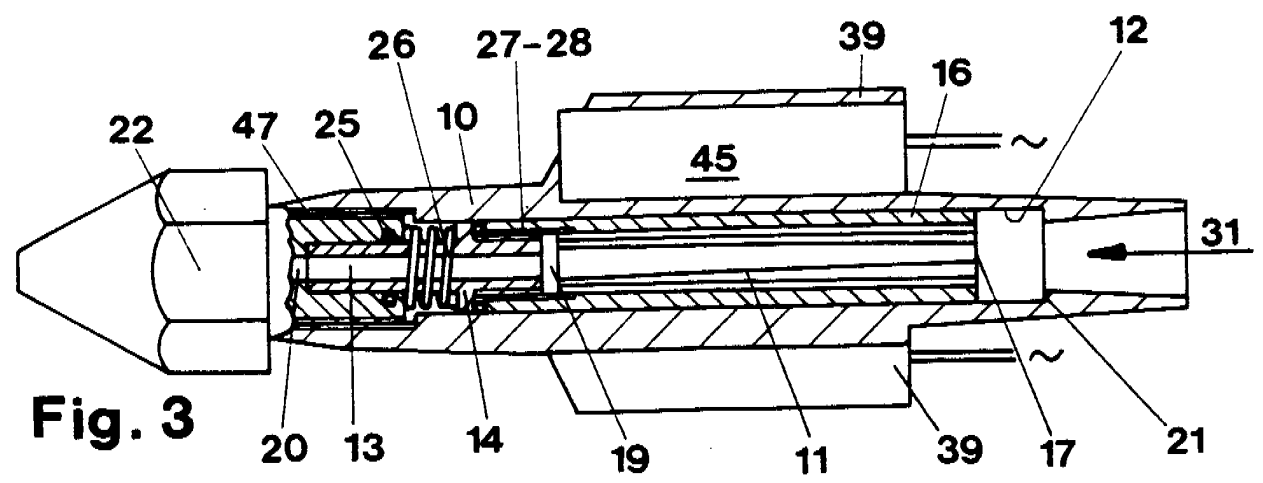

**Fig. 3**



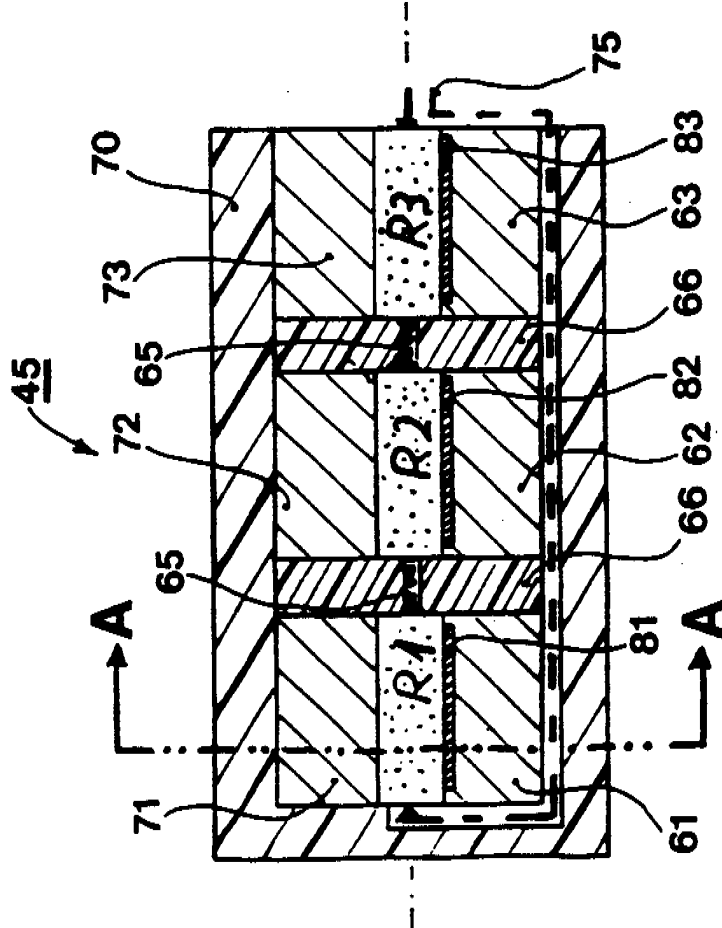

Fig. 4

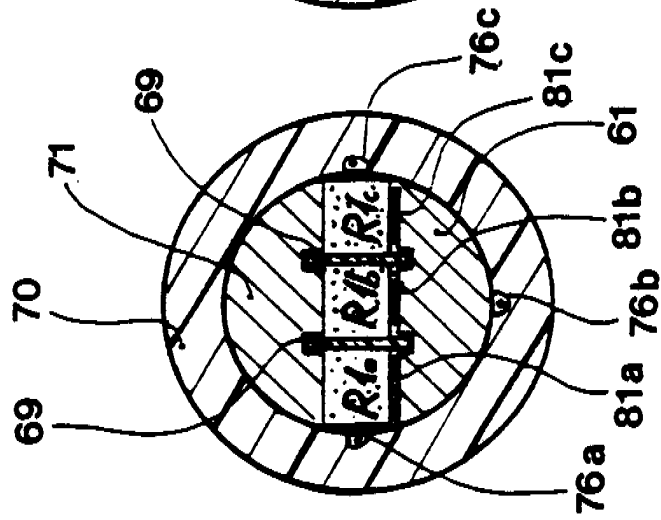

Fig. 5

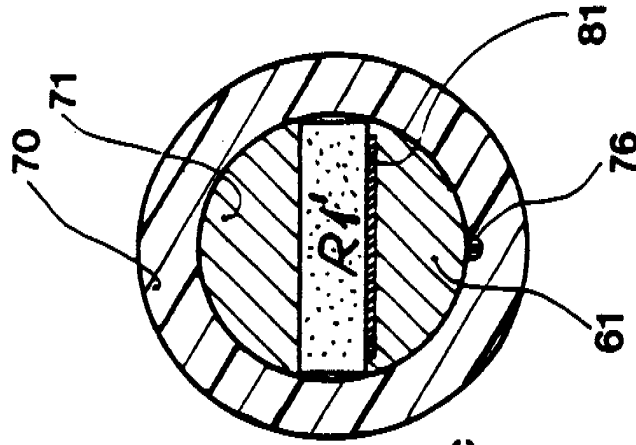

Fig. 6

### Communication

Examination of the application has shown that it does not meet the requirements of the European Patent Convention for the reasons set out below.

If nevertheless you wish to continue with the application you are requested to file your observations and arguments, together with any amendments to the application documents.

1. Document II, cited for the first time in this Communication, discloses a device for melting and dispensing thermoplastic material having a heating means (22), a melting chamber (the ribbed heating element) slideably mounted in the device and with an inlet and an outlet for the unmelted and molten material respectively, and a resilient element (14) whose return force acts on the melting chamber.

The subject-matter of claim 1 accordingly lacks novelty.

2. In the known device the melting chamber can, furthermore, slide axially in a heating tube (the heater sleeve 10) on which the heating means is located, the melting chamber being in thermal contact with the heating tube. The melting chamber has inwardly projecting heating fins (27) arranged lengthwise whose heat transfer surface increases continuously towards the outlet. The heating means is electric and has a PTC resistor.

The subject-matter of claims 2, 3 and 5 accordingly also lacks novelty in view of Document II.

3. Claim 4 relates to the design of the resilient element as a coil spring. Since the use of a coil spring as a resilient element is known from Document I for a device of the same type and to solve the same problem (to exert a return force on the thermoplastic material fed in under pressure in solid form when the pressure is released), it was obvious to the person skilled in the art to replace the metal bellows known from Document II by a coil spring which is a clear technical equivalent in terms of the problem to be solved.

The subject-matter of claim 4 does not therefore involve an inventive step.

4. The PTC resistor of the device known from Document II, which also extends along the length of the melting chamber (ribbed heating element) since it consists of a resistor wire wound helically along the coaxially disposed heating tube (heater sleeve 10), is regarded as being equivalent to the series connection of the resistor elements as claimed in claim 6. As the parallel connection claimed in claim 7 has also already been considered as a possibility in Document II (page 2, paragraph 2), the subject-matter of these claims is considered to represent mere design features that can be expected of the skilled person without involving an inventive step.
5. The heating cartridge design as claimed in claim 8 also does not involve any special features but concerns merely principles for successful heat transfer generally known to the

skilled person with due regard for electrical insulation requirements. No surprising effect is achieved by this design and accordingly it cannot be considered inventive.

6. The subject-matter of claim 9 also cannot be regarded as inventive, since such melting devices are conventionally used in hot-melt glue guns, as the cited documents show.
7. Consequently, none of the claims are allowable owing to an absence of novelty or inventive step, Articles 52(1), 54 and 56 EPC.
8. In the opinion of the Examining Division the application as a whole does not contain subject-matter on which grant of a patent might be considered.

Should you, however, wish to file new claims in spite of the above objections, the independent claim or claims should be correctly delimited with respect to the most relevant prior art, Rule 29(1) EPC.

The description should if necessary be adapted to meet the requirements of Article 84 and Rule 27 EPC.

Text of Document I (State of the Art)

The device shown in the drawing is used in a hot-melt glue gun. With such guns it is vital to avoid the drooling of molten material from the nozzle orifice when application of the adhesive is terminated.

5

The device shown in the Figure has a body 10 made of material which is a very good conductor of heat and having a melting chamber 12 with a conical interior surface 14 and a hollow cylindrical part 16. In the hollow cylindrical part 16 of the melting chamber 12 is a coil spring 26 which is fixed at its front end to a shoulder of the melting chamber. The rear end of the spring acts on the front end of a rod of adhesive 11 inserted in the device.

15 In a housing 34 of the device there is provided a thermostat-controlled electric heating device 36 for heating the melting chamber 12. Attached to the inlet 18 of the body 10 is a resilient silicone rubber tube 28 which forms an extension of the hollow cylindrical part 16 of the body, the tube having an inlet 20 30. The silicone rubber tube 28 has on its inside, adjacent to the inlet 30, a resilient lip 32 of circular cross-section. When a rod of adhesive 11 inserted through the inlet 30 into the silicone rubber tube, it is gripped and held by the lip 32.

25 When the device described is used in a hot-melt glue gun, a rod of adhesive 11 is pushed under pressure through the inlet 30 against the coil spring 26 into the melting chamber 12 where the rod is melted.

30 The liquid adhesive emerges from the nozzle assembly orifice 22 via a one-way ball valve 24. When application of the adhesive is terminated by releasing the pressure exerted on the rod, the coil

spring 26 acts on the unmelted part of the rod 11 and pushes rod back. This removes the pressure on the molten adhesive in melting chamber 12. As a result of the reduced pressure thereby produced, some liquid adhesive is sucked in a rearwards direction  
5 from the melting chamber, and consequently drooling from the nozzle assembly orifice 22 is prevented when application of the adhesive is terminated.

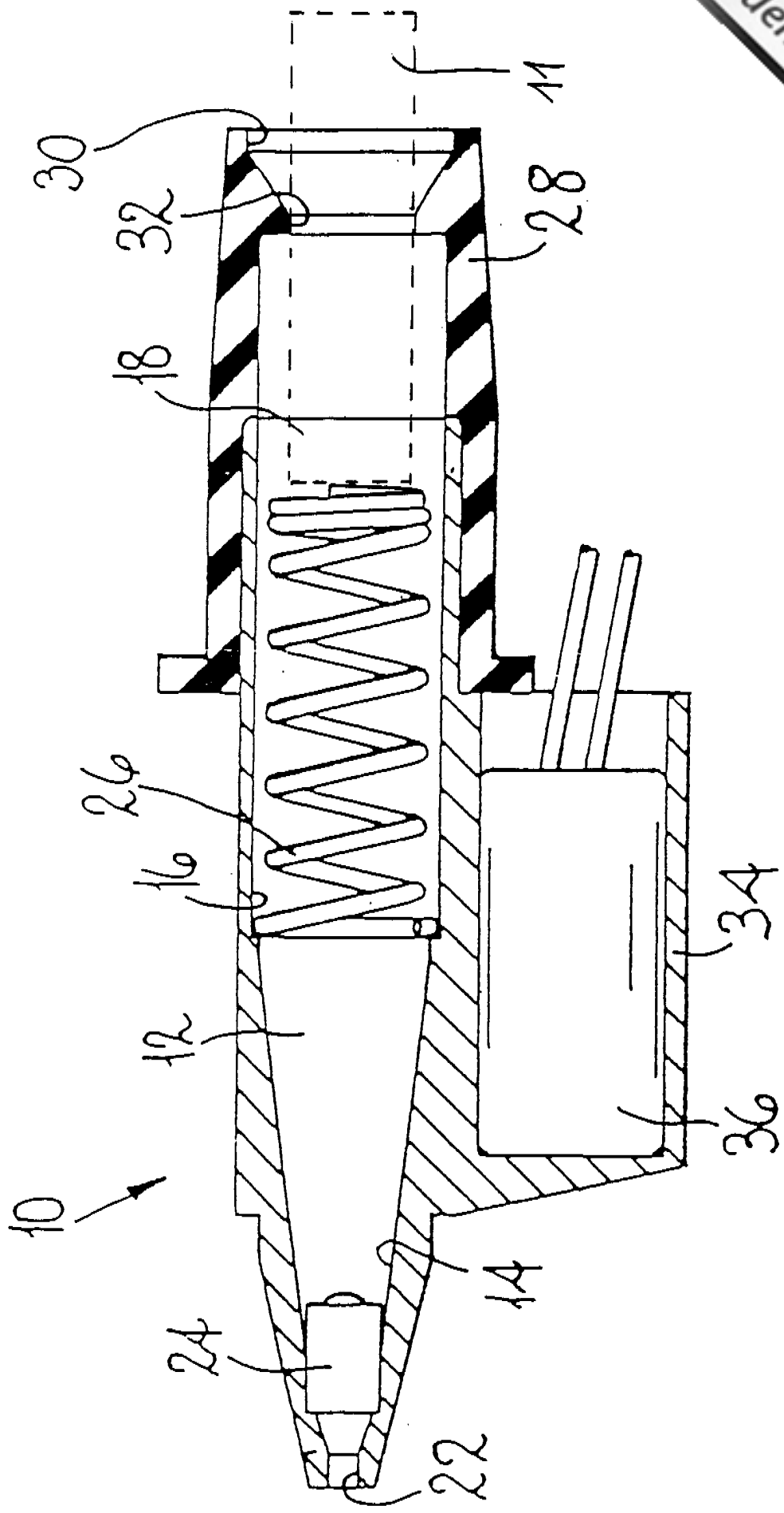



Text of Document II (State of the Art)

The invention relates to a device in the form of a gun used for the delivery of small quantities of fusible thermoplastic compounds such as adhesives.

5 The device consists of a heater sleeve into which a rod of the fusible thermoplastic compound is introduced. The sleeve is surrounded by a resistor with a positive temperature coefficient, which with an increase in temperature causes a reduction in the output of heat from the resistor to the heater sleeve at a  
10 constant supply voltage. The heater sleeve and resistor are additionally surrounded by an insulating sleeve. A constant temperature of the heating sleeve is thus achieved in use of the device without the need for an additional temperature adjustment.

15

In the drawings:-

Figure 1 shows a diagrammatic longitudinal section through the plane of symmetry of a gun-type device for thermoplastic  
20 adhesives;

Figure 2 shows a view of the free end of the heater sleeve of the device shown in Figure 1;

25 Figure 3 shows a section taken on line III-III of Figure 2.

The device has a gun-shaped housing. The gun butt is connected to the sheath of an electrical supply line.

30 A heater sleeve 10 made of a light metal alloy, shown in detail in Figures 2 and 3 and extending inside the gun-shaped housing, has a cylindrical inlet end 11, the outside of which has lugs 12 which engage in corresponding recesses 13 of the housing.

The part of the heater sleeve 10 outside the housing has an end flange 18 which engages the front end of an insulating sleeve 20 whose back end engages in a recess 21 in a mounting 8.

- 5 A heating resistor 22 with a positive temperature coefficient, consisting of a single wire winding or a number of wire windings connected in parallel, is arranged on the heater sleeve 10 in the space between the heater sleeve and insulating sleeve 20.
- 10 The front of the heater sleeve 10 has a nozzle assembly 24.

As shown clearly in Figures 2 and 3, the inlet 11 and the front orifice of the heater sleeve communicate via an initially cylindrical and then tapered bore 26 containing a ribbed heating element with four longitudinal ribs 27. The ribbed heating element can be moved axially by a resilient metal bellows 14, one end of which is soldered to the ribbed heating element. The other end of the metal bellows is soldered to the inlet 11.

20 The individual ribs 27 are of triangular cross-section, as shown in Figure 2, and end at the bottom of the tapered bore in a cruciform orifice 28. The tapered bore in the heater sleeve 10 creates good heat transfer from the heater sleeve to the ribbed heating element when a rod of adhesive is pushed into the ribbed heating element. The ribbed heating element is thereby moved in the feed direction of the rod with consequent expansion of the metal bellows 14, until the ribbed heating element achieves a close fit with the tapered part of the bore 26 of the heater sleeve 10.

30 If the pressure on the rod is relaxed, the metal bellows contracts and pulls the ribbed heating element together with the unmelted part of the rod back against the feed direction of the rod. As a result of the vacuum thus produced in the outlet area of the heater sleeve, molten thermoplastic material is sucked back and in this way drool from the gun is prevented at the end of the cycle.

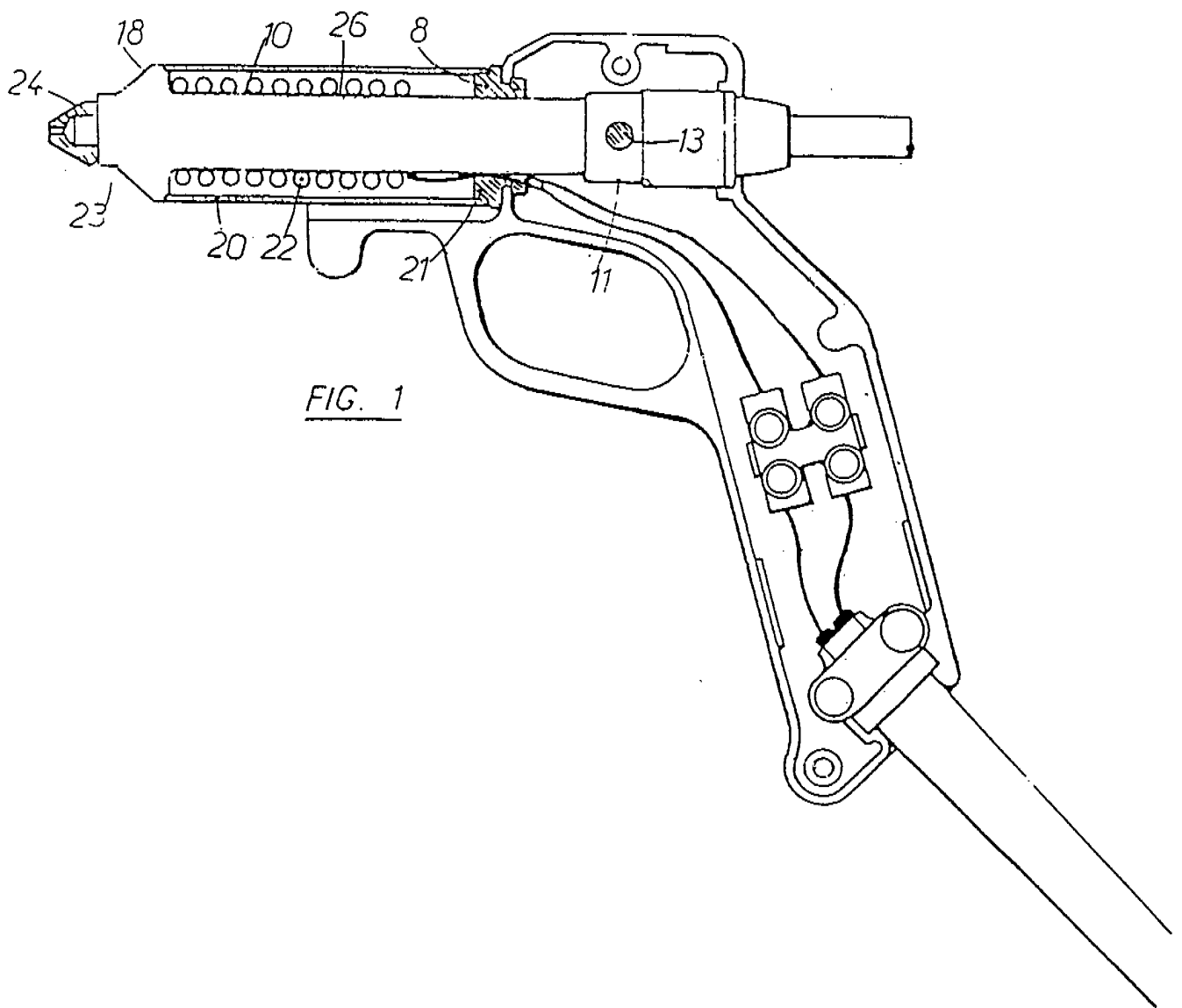

FIG. 1

