

EUROPEAN QUALIFYING EXAMINATION 1990

**PAPER B
ELECTRICITY / MECHANICS**

This paper comprises:

- Instructions to Candidates 90/B(E/M)/e/1-2
- Description of the Application 90/B(E/M)/e/3-12
- Claims 90/B(E/M)/e/13-14
- Drawings of the Application 90/B(E/M)/e/15-17
- Communication 90/B(E/M)/e/18-20
- Text of Document I (State of the Art) 90/B(E/M)/e/21-22
- Drawings of Document I (State of the Art) 90/B(E/M)/e/23
- Text of Document II (State of the Art) 90/B(E/M)/e/24-25
- Drawings of Document II (State of the Art) 90/B(E/M)/e/26

INSTRUCTIONS TO CANDIDATES

In this paper, you should assume that a European patent application comprising the appended documents* has been filed and that the European Patent Office has communicated the annexed official letter.

You should accept the facts given in the paper and base your answers upon such facts. Whether and to what extent these facts are used is your responsibility.

You should not use any special knowledge you may have of the subject-matter of the invention, but are to assume that the prior art given is in fact exhaustive.

Your task is now to draft a full response to the official letter. The official letter may or may not necessitate amendment of the description or claims or both and may or may not require arguments, for example as to the relevance of the prior art. You should bear in mind, in drafting your response, that the claims should afford the maximum valid protection. The response should be a letter to the EPO, but no particular form is mandatory. Any amendments should be clearly stated as insertions or deletions in the response or set out in a separate document. In any case, the amendments proposed should be sufficient to meet the requirements of the Convention as to both claims and description.

* These documents do not necessarily constitute the only or best solution to the task set in Paper A (Electricity/Mechanics).

If your response includes a proposal to make any part application the subject of a divisional application, you should suggest a text for at least the main claim of the divisional application and also indicate, where appropriate, your grounds for considering such claim to be acceptable. You need not however propose an introduction for any divisional application.

In addition to your elaborated solution, you may - but this is not mandatory - give, on a separate sheet of paper, the reasons for your choice of solution, for example, why you selected a particular form of claim, a particular feature for an independent claim, a particular piece of prior art as starting point or why you rejected or preferred some piece of prior art. Any such statement should however be brief.

It is assumed that you have studied the examination paper in the language in which you have given your answer. If this is not so, please indicate on the front page of your answer in which language you have studied the examination paper. This always applies to candidates who - after having filed such a request when enrolling for the examination - give their answer in a language other than German, English or French.

Description of the Application

Induction Furnace

The present invention relates to an induction furnace comprising a furnace hearth, at least one channel communicating at both ends with the hearth and an induction heater, the induction heater generating a magnetic flux
5 intersecting a portion of the channel so as to heat metal in the channel by magnetic induction. Particularly, but not exclusively, the invention relates to such a furnace adapted for use as a zinc coating bath; such baths are used in industry for zinc coating items
10 as diverse as fence posts and car bodies by dipping them in the bath.

The traditional zinc bath consists of a general purpose furnace for melting metal, for example a refractory pot
15 or hearth in which the solid metal is heated up from cold by a gas heater, usually mounted below the pot; once the zinc is liquid and the bath is ready for use the gas must be switched off as the coating process produces dross, oxide and other impurities which sink to
20 the bottom of the bath. If the bath were heated during dipping these impurities would rise by convection into the dipping zone. It is therefore important to keep the bottom portion of the bath undisturbed so that impurities may settle there.

25

The traditional bath has the disadvantage that plating has to be interrupted at regular intervals, firstly to reheat the zinc, which of course cools with time, and secondly to allow the impurities to be removed or to re-
30 settle after the heating. A zinc coating bath which overcomes this disadvantage is known from Document I, which makes use of induction heating.

In induction heating the zinc is exposed to an intense alternating magnetic field by passing a current through an electromagnet winding surrounding a portion of the bath; this field induces circulating electrical currents 5 in the zinc which heat it up. The electromagnet winding can be considered as the primary winding of a transformer, the molten metal constituting a short-circuited secondary winding. The "secondary winding" has a finite resistance and is heated by the current.

10

In the Document I bath an induction heater is mounted on the side of the hearth and is connected to the hearth by channels which permit convective flow of hot molten metal from the heater to the hearth and return of cooler 15 metal in the opposite direction. The channels communicate with the hearth near its open top, so that the impurities which accumulate at the bottom of the hearth are largely left undisturbed. Since the zinc is heated directly its temperature can be accurately controlled.

20

The Document I bath, although a major advance on the traditional bath, does have certain disadvantages, particularly in the start-up phase. The position and construction of the heater are such that it cannot easily 25 melt solid zinc from cold; the hearth must first be charged with molten zinc, up to and including the heater channels, and even then cannot melt subsequently added solid zinc within a reasonable time because of the slow convection in the relatively long channels joining the 30 heater with the hearth. It is therefore necessary to provide a separate furnace to melt the zinc before charging the entire bath. The channels must initially

be kept free of solid zinc, which could slow down convection during start-up, and after use the molten zinc must be drained by means of the plugs shown in Fig 2 of Document I, as otherwise restarting would be slowed by the solidified zinc. Since heated zinc is supplied by the heater to the top of the bath and there is little convection, a substantial temperature gradient exists which can adversely affect the quality of coated products.

10

The invention accordingly has as its object the provision of a furnace using an induction heater, the furnace requiring a minimal charge of molten metal and being usable as a zinc coating bath in which impurities are hindered from rising into the coating zone and an even temperature is maintained in this zone.

In accordance with the invention the channel and induction heater are located under the hearth. In consequence, it is no longer necessary to charge the whole hearth before the channel can be charged.

The channel may consist of a single loop and the induction heater may comprise a transformer core passing through the loop and an induction winding on the core. Alternatively, the channel may consist of two loops, and the induction heater comprise a transformer core passing through both loops and at least one induction winding on the core. The two loops can share a common channel over part of their lengths. The two-loop embodiment is particularly suitable if the furnace of the invention is used as a zinc coating bath as for a given throughput the speed of flow is slower.

In use of the furnace of the invention as a zinc coating bath additional precautions are preferably taken to control the speed of convection in order to prevent impurities from reaching the dipping zone, whilst maintaining an even temperature in this zone. In one embodiment, the induction winding is arranged to generate a magnetic field which rotates with respect to the core axis. The rotating magnetic field can regulate the speed of flow through the heater in accordance with the working parameters of the hearth.

The or each loop can be provided with a non-uniform cross-section along its length. In one such arrangement the or each loop has a constant cross-sectional area and the loop width in a direction parallel to the core axis decreases linearly with distance from the hearth, whereby the loop cross-section is elongate adjacent the hearth and square at its point furthest from the hearth. This arrangement avoids a problem which arises in induction heaters, the so-called magnetic pinch effect.

Whenever current flows in a conductor, the magnetic field which is set up exerts a compressive effect on the conductor perpendicular to the direction of the current; in a liquid conductor this effect may be great enough to cut the conductor and thereby break the continuity of the circuit. This can be disastrous in a bath as the result is to send a series of shock waves through the molten metal as the circuit through the metal is interrupted and the current collapses; once the current has collapsed the pinch effect ceases and the circuit is re-established so that the process repeats itself. The resultant shock waves can damage the sensitive refractory lining of the furnace and can be dangerous to the operating personnel. By use of the above-mentioned cross-section the pinch effect can be avoided and a higher power input to the heater enabled.

The cross-sectional area may alternatively increase early from one end of the loop to the other, whereby unidirectional circulation is established in the loop.

5 Finally, in a further modification a plug is provided at the lowest point of the loop or loops and by turning off the power to the induction windings at regular intervals, the impurities can be allowed to settle and be drained off.

10

The furnace of the invention is as noted above particularly suitable for use as a zinc coating bath.

A detailed explanation of the invention can be found in
15 the accompanying description and drawings.

In the drawings:-

Fig. 1 is a part sectional view of a first zinc coating
20 bath according to the invention;

Fig. 2 is a part sectional view of a second zinc coating bath according to the invention;

25 Fig. 3 shows the use of a rotating magnetic field to control flow speed and direction in the Fig. 1 embodiment;

Fig. 4 shows the use of two magnetic fields rotating in
30 opposite directions to control flow in the Fig. 2 embodiment; and

Fig. 5 shows in section a modification of the Fig. 1 bath, whilst Figs. 5a and 5b respectively show a section
35 taken on the line V-V in Fig. 5 and cross-sections of the channel at differing locations.

The zinc coating bath shown in Fig. 1 comprises a cylindrical hearth 1 whose walls are made in known manner of a refractory layer of substantial thickness. The refractory layer has a flat bottom 1a to which a channel 2 with refractory walls 3 is mounted, the channel forming a loop in a vertical plane and communicating with diametrically opposite sides of the hearth bottom. The channel has a constant circular cross-section over most of its length but at its ends flares outwardly towards the hearth, the hearth and channel walls cooperating to minimise turbulence in the flow of the molten zinc. The refractory walls of the hearth and channel can be formed in known manner of, for example, refractory bricks, the rigidity of the assembly being assured by rings of concrete 5 with an additional outer metal casing 4 adjacent the channel.

An induction heater is located below the hearth. The heater includes a transformer core 6 of circular cross-section passing through the middle of the loop formed by channel 2. Transformer yokes 8,9 extend around the exterior of the channel assembly and, together with the core 6, form a closed magnetic circuit for the magnetic flux generated by induction windings 10 mounted on the core. Cooling means (not shown) surround the windings and serve to prevent the build-up of excessive heat.

The windings serve to generate an axial magnetic field which permeates the transformer core and yokes; this axial field penetrates the molten metal and in known manner induces heating currents in it. The windings also generate a rotating magnetic field which serves to regulate the circulation of the molten zinc inside the channel. Referring to Fig. 3, it will be seen that the

rotating field is analogous to that of a bar magnet rotating about the axis of the core 6. This rotating field exerts a force F on the molten metal in the channel 2 analogous to that exerted on the armature of an electric motor. By controlling the speed of rotation of the rotating field the speed of the molten metal can be controlled.

The rotating and axial fields can in principle be generated by two independent sets of windings but it has been found convenient in practice to provide a single set of windings for both. In consequence, the rotating field rotates at a predetermined fixed speed which is a function of the supply frequency and the winding configuration. The manner of winding to provide a rotating field component, and the necessary control circuitry, are well known in the electrical motor art and will not be described further.

In use, the channel is charged with a sufficient quantity of molten zinc to fill it completely and power is gradually applied to the heater. The power applied in the warm-up phase is controlled to avoid the pinch effect and to prevent overheating of the zinc, which circulates poorly until the entire hearth contents are fully molten. Zinc is continuously added either in molten or powdered form until the hearth is fully charged, at which time full power can be applied. The molten zinc is thereafter maintained at a predetermined operating temperature by means of a thermostatic control loop of known kind (not shown). The rotating field ensures that the flow of zinc in the channel is unidirectional and of predetermined speed. The speed is kept

sufficiently low to ensure that impurities are not carried into the dipping zone at the top of the hearth, but sink back under their own weight before reaching this zone, whilst nevertheless maintaining a constant temperature throughout the dipping zone.

In Fig. 1 the bath is provided with a single channel; however a plurality of channels with respective windings may be provided. Such an arrangement is useful in zinc coating because it has the advantage that for a given throughput of molten zinc the speed of flow and thus the convection is slower. Fig. 2 shows an example of such an arrangement, elements which have the same construction or function as in Fig. 1 bearing the same reference numerals. In this embodiment two outer channels 2a, 2b are located in a common plane and share an inner channel 2c. The channels have respective cores 6 and windings 10, the cores being joined by yokes 8 to form a common magnetic circuit. The windings 10 are arranged in such a way as to generate magnetic fields rotating in opposite senses, as shown in Fig. 4, such that the molten metal enters through the outer channels 2a, 2b and flows back to the hearth by way of the common inner channel 2c. The Fig. 2 bath is used in a similar manner to that of Fig. 1. Because two channels are provided the speed of flow in each channel can be reduced in comparison with the Fig. 1 embodiment, thereby reducing the danger of impurities entering the dipping zone.

It will be understood that numerous modifications of above-described zinc coating baths are feasible. For example, considerable simplification of the induction heater windings is possible if the rotating field component is not required. Although full control of zinc flow in the channel(s) is thereby sacrificed, stability of flow both as regards speed of flow and the pinch effect can be provided by mechanical means as described below.

10

Figs. 5 shows a modification of the Fig. 1 arrangement in which a winding is used which does not give rise to the rotating field component. Like parts are designated by the same reference numerals as in Figs. 1 and 2. A channel is provided which has a constant cross-sectional area over its length but, as shown in Fig. 5a, has a width measured parallel to the core axis which decreases linearly from the hearth bottom to the lowest point of the channel, such that at the lowest point, see Fig. 5b, the channel cross-section is square whilst towards the hearth it is elongate. This channel has about half the cross-sectional area of that of the Fig.1 embodiment in order to reduce the flow rate; it has been found that the reduced flow rate and channel geometry serve to maintain convection at acceptable levels.

Because of the square cross-section the pinch force is strongest at the lowest point of the channel, at which point however the hydrostatic pressure exerted by the molten metal is also at a maximum. Closer to the hearth the pinch effect is reduced by reason of the elongate channel cross-section, which is balanced by the lower hydrostatic pressure. Thus, more power can be applied to the bath than if the channel were of the same cross-section throughout. The Fig. 5 channel

35

arrangement can moreover be used with a plurality of channels as in Fig. 2, and can be combined with the induction heater of Fig. 1, so as to provide a rotating field component, thereby enabling more power to be applied whilst maintaining flow control and avoiding the pinch effect.

In a further modification, not shown in Fig. 5, the cross-sectional area increases linearly from one channel end to the other. This ensures unidirectional circulation in the channel.

As shown in Fig. 5 a plug is preferably provided at the lowest point of the channel to enable drainage of molten metal and/or impurities. By turning off the power to the induction heater at regular intervals, the impurities can be allowed to settle and be tapped off. It will be understood that in the absence of such a plug impurities will tend to collect in the channel and obstruct the flow.

C l a i m s

- (1) An induction furnace comprising a furnace hearth (1), at least one channel (2;2a,2b,2c) communicating at both ends with the hearth, and an induction heater (6,8,9,10;6,8,10), the induction heater generating a magnetic flux intersecting a portion of the channel so as to heat metal in the channel by magnetic induction, characterised in that the channel and induction heater are located under the hearth.
- (2) An induction furnace as claimed in claim 1, characterised in that the channel consists of a single loop (2), and that the induction heater comprises a transformer core (6) passing through the loop and an induction winding (10) on the core.
- (3) An induction furnace as claimed in claim 1, characterised in that the channel consists of two loops (2a,2b,2c), and that the induction heater comprises a transformer core (6) passing through both loops and at least one induction winding (10) on the core.
- (4) An induction furnace as claimed in claim 3, characterised in that the two loops (2a,2b,2c) share a common channel (2c) over part of their lengths.
- (5) An induction furnace as claimed in any one of claims 2 to 4, characterised in that the induction winding is arranged to generate a magnetic field which rotates with respect to the core axis.

- (6) An induction furnace as claimed in any one of claims 2 to 4, characterised in that the or each loop is provided with a non-uniform cross-section along its length.
- (7) An induction furnace as claimed in claim 6, characterised in that the or each loop has a cross-sectional area which increases linearly from one end of the loop to the other.
- (8) An induction furnace as claimed in claim 6, characterised in that the or each loop has a constant cross-sectional area along its length and that the loop width in a direction parallel to the core axis decreases linearly with distance from the hearth, whereby the loop cross-section is elongate (21) adjacent the hearth and square (20) at its point furthest from the hearth.
- (9) An induction furnace as claimed in any preceding claim, characterised in that the or each loop has at its lowest point a plug (25) closing an opening through which molten metal and/or impurities may be drained.
- (10) A zinc coating bath comprising an induction furnace as claimed in any preceding claim.

Fig. 1

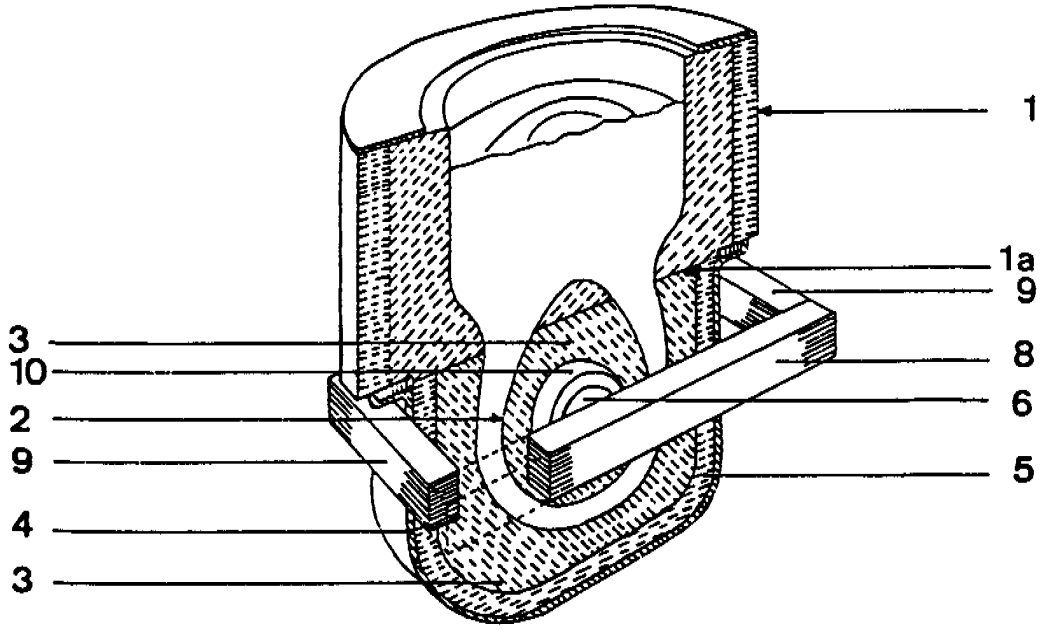

Fig. 2

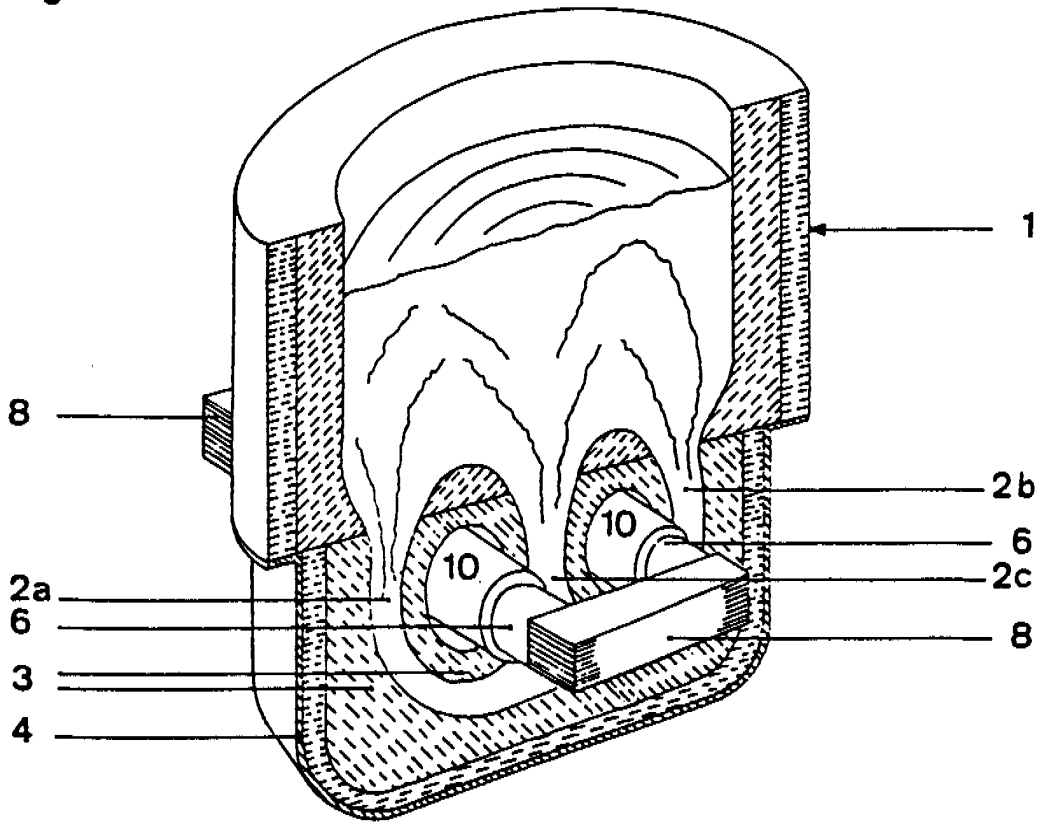

Fig.3

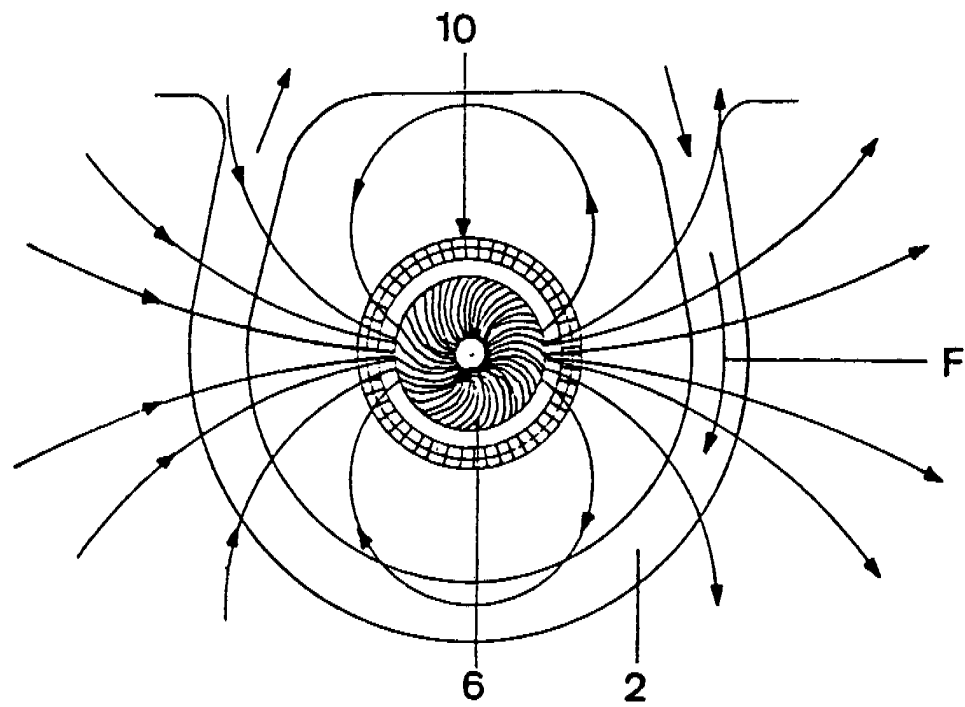

Fig.4

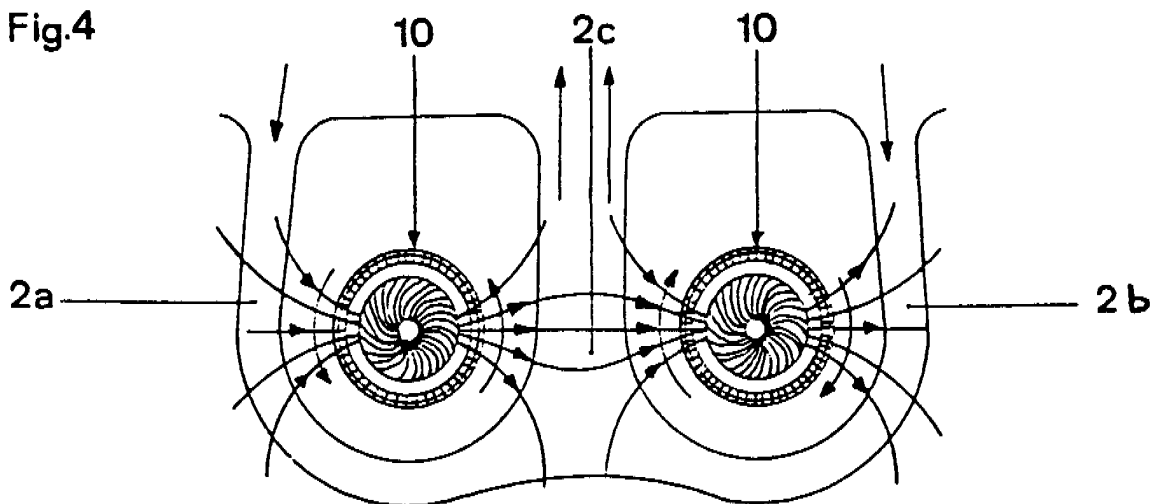

Fig. 5

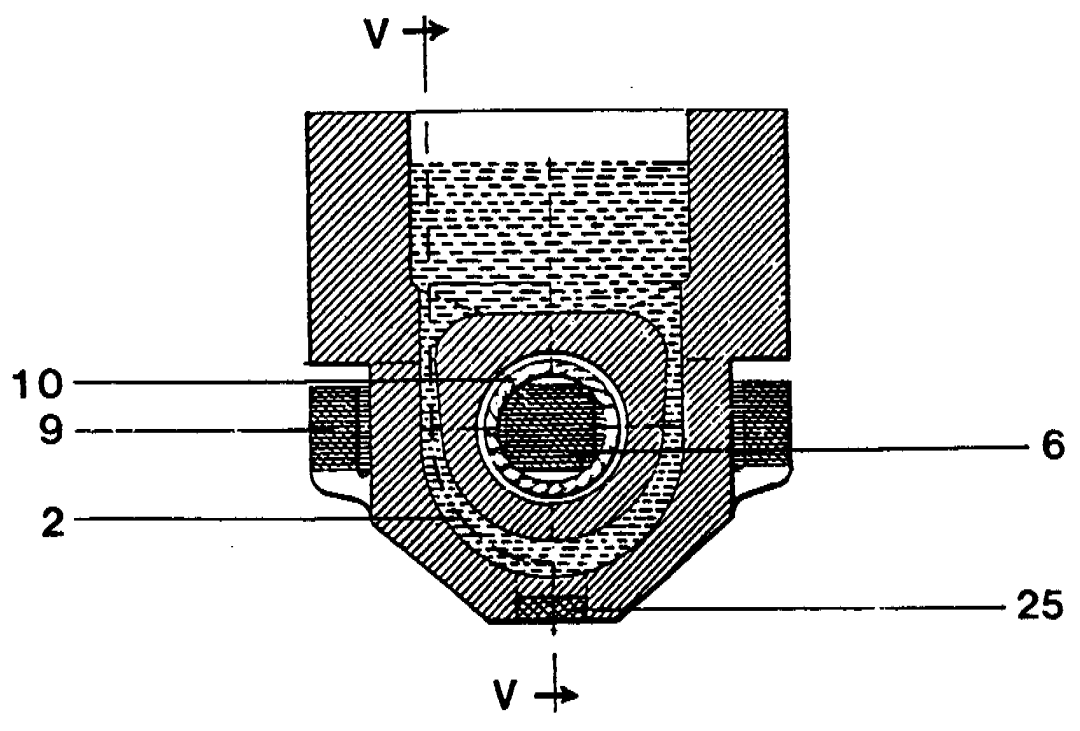
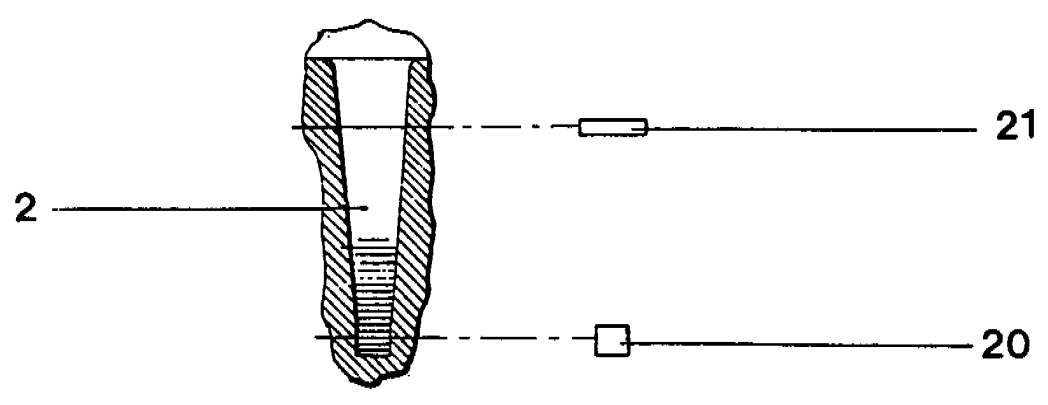

Fig. 5 a

Fig. 5 b



Communication

Examination of the application has shown that it does not meet the requirements of the European Patent Convention for the reasons set out below.

If nevertheless you wish to continue with the application you are requested to file your observations together with any amendments.

1. Document II discloses an induction furnace which can be seen from Fig. 1 to have a hearth and channels 8, 9 communicating at both ends with the hearth. The winding 10, 11 of an induction heater generates a magnetic flux intersecting the respective channels so as to heat the metal in the channels by magnetic induction. Both the channels 8, 9 and the windings 10, 11 are located under the hearth.

The subject-matter of claim 1 accordingly lacks novelty, Articles 52(1) and 54 EPC.

2. Document II discloses two single loops 8, 9 extending under the hearth and transformer cores 12, 13 on which respective induction windings 10, 11 are located.

The subject-matter of each of claims 2 and 3 accordingly lacks novelty.

3. The use of two loops sharing a common channel is known per se from Document I. It would be obvious to the skilled man that he could use the Document I loop arrangement in the furnace of Document II.

The subject-matter of claim 4 accordingly lacks an inventive step, Articles 52(1) and 56 EPC.

4. The generation of rotating electrical fields in order to effect rotation of a member is general knowledge in the electrical motor art. Induction furnace windings are generally constructed by electric motor manufacturers, so that the skilled man in the art would appreciate that he could provide rotational movement of the molten metal in the channel by the use of a rotating field as specified in claim 5.

The subject-matter of claim 5 does not therefore involve an inventive step.

5. In Document II each loop is flared, i.e. has a non-uniform cross-section along its length.

The subject-matter of claim 6 accordingly lacks novelty.

6. The provision of unidirectional circulation is implicit in Document I since the central channel 9 has the same cross-sectional area as each side channel 8, 10 but must handle twice the flow volume. Whether the provision of unidirectional circulation is by means of a step change in cross-section, as in Document I, or a linear change, as specified in claims 7 and 8, is inherently trivial. Moreover, with reference to claim 8, it can be seen in Document I that the cross-section is square in one part of the loop (channels 8, 9, 10) and elongate in another (bottom channel 21).

The subject-matter of each of claims 7 and 8 does not therefore involve an inventive step.

7. The use of drain plugs is known per se from Document I see Fig. 2. It would be obvious to the skilled man that he could provide such plugs in a furnace as known from Document II.

The subject-matter of claim 9 therefore also lacks an inventive step.

8. The subject-matter of claim 10 does not involve an inventive step. It would be obvious to the skilled man that he could modify the zinc coating furnace known from Document I to take account of the teaching of Document II.
9. In the opinion of the Examining Division the application as a whole does not contain subject-matter on which grant of a patent might be envisaged.

Should you, however, file new claims in spite of the above objections, the independent claim or claims should be correctly delimited with respect to the most relevant prior art, Rule 29(1) EPC.

The description should if necessary be adapted to meet the requirements of Rule 27 EPC.

TEXT OF DOCUMENT I (State of the Art)

In the drawings:-

Fig. 1 is a sectional view of a metal coating bath; and

5 Fig. 2 is a sectional view on line II-II of Fig. 1.

The bath 1 consists of a steel casing 2 which is provided with a refractory lining 3 enclosing the hearth 12; an inclined opening or passage 5 is provided in the
10 side wall 7, the passage 5 flaring out into the upper portion of the bath space.

A double-coil inductor unit 11 is attached to the wall 7 in such a manner that the inclination of the melting
15 channels 8, 9, 10 is in alignment with the wall opening or passage 5 and the metal flow only reaches the upper portion of the bath. The refractory lining 3 of the bath has an extension 6 for attachment to the inductor unit.

20

This replaceable inductor unit consists of a refractory block 13 which is surrounded by a steel casing 14. The unit contains two copper coils 15 on opposing sides of an iron core 16 which forms a closed magnetic path. The
25 magnetic flux generated by the coils intersects the melting loop, which is formed of a bottom channel 21 and the three melting channels, 8, 9, 10 connecting at their lower ends with the bottom channel and at their upper ends with passage 5. Channel 21 is closed by refractory
30 plugs 17, see Fig. 2.

The melting channels 8, 9, 10 of the inductor unit extend, as stated above, in the same inclined direction as

the passage 5; the inclination of the channels permits convective flow of hot molten metal from the inductor unit to the hearth and return of cooler metal in the opposite direction.

5

The metal, for example zinc or any other metal for which the impurities settle, is constantly heated in the inductor unit and enters into the upper portion of the bath; the bottom section therefore remains undisturbed.

10

Contamination of the metal in the upper portion of the bath is eliminated; the settling of dross, metal oxides and other impurities on the bottom of the bath is undisturbed. Because the centre axes 20 of the inclined channels extend towards the open top of the furnace and refractory plugs 17 are provided in the bottom channel 21, the melting channels of the inductor unit can be cleared of metal and can easily be reached and cleaned with cleaning tools.

15

20

In use of the bath, the lining 3 is pre-heated in a suitable manner. Molten metal is charged into the hearth 12 until the metal overflows into and fills the melting loop of the inductor unit; the current is gradually switched on until full power is reached and the hearth is filled to the level 18. The metal is continuously heated in the melting loop, from where it circulates into the upper working zone of the bath. Fresh metal may be charged into the hearth 12 as required. The articles to be coated are introduced from above in the usual manner.

25

30

The inductor unit 11 is detachable and can be easily replaced, if necessary. Since the furnace can be operated within an exactly controlled narrow temperature range wear is greatly reduced.

35

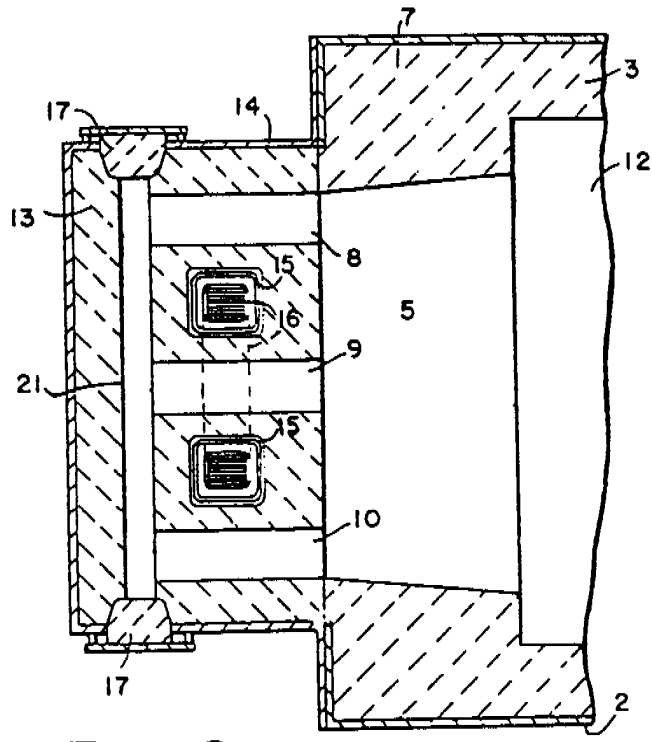
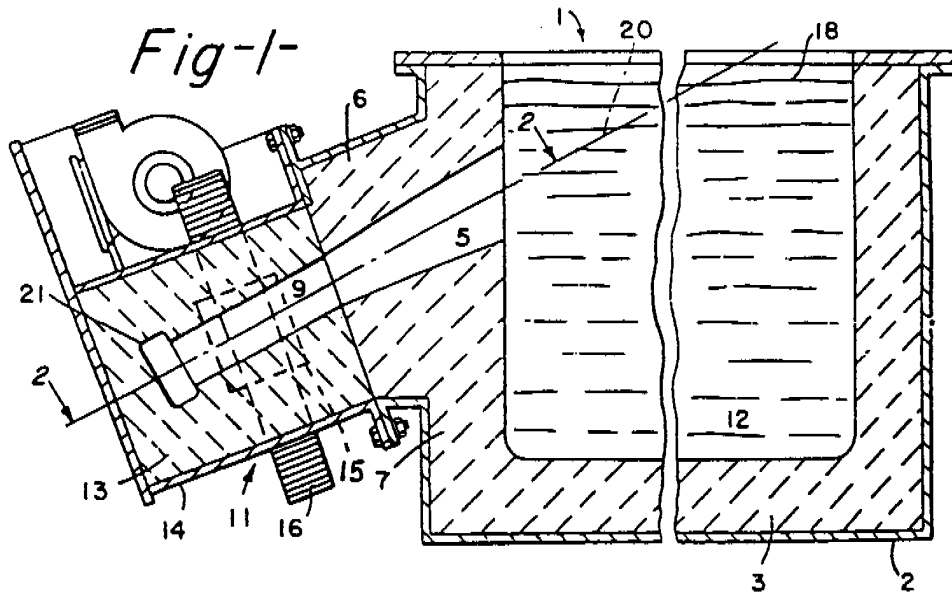

Fig-2-

TEXT OF DOCUMENT II (State of the Art)

My invention relates to improvements in metal furnaces and combines advantageous features of furnaces of the induction type and the electric arc type.

5 To start an induction furnace it is necessary first to fill the chamber with molten metal which, according to the present practice, is obtained from a fuel or other furnace. My invention overcomes the need for obtaining molten metal from an outside source by introducing into the furnace chamber one or
10 more electrodes for generating electric arcs which are used initially to melt sufficient metal to fill the induction loops; thereafter the furnace temperature is maintained by use of induction heating, although a combination of induction and arc heating could be used.

15

The furnace is designed to enable a wide range of metals to be melted. For example, it can be used for the manufacture of high grade alloy steel by removing the arcing electrodes after initial melting of the metal and providing a high power
20 input to the inductor windings so as to cause the so-called "pinch" effect in the molten metal; the resultant vigorous circulation helps dissolve the alloy components. For other metals and other uses a vigorous circulation may not be desired, in which case the power input to the induction wind-
25 ings is reduced.

In the drawings:-

Figure 1 represents in vertical section a furnace embodying
30 one specific form of my invention; and

Figure 2 is a section taken on line II-II of Figure 1.

The furnace here shown comprises, among other parts, a roof
35 1, side walls 2 and bottom 3, all of any suitable refractory

90/B(E/M)/e/24

.../.

material. The bottom 3 has two extensions 4 and 5 project downwardly from the bottom proper at an angle shown. These projections are pierced, respectively, by openings 6 and 7 causing the extensions to form two loops. In these loops are formed, respectively, channels 8 and 9, each channel following the arc of a circle at the lower end of the loop, and gradually expanding or widening upward where it merges into the chamber proper of the furnace. In cross section, these channels are oval-shaped, as shown in Fig.2. The openings 6 and 7 receive heating coils 10 and 11 wound on cores 12 and 13 provided, respectively, with laminated yokes 14 and 15.

Extending vertically through the roof of the furnace are three arcing electrodes 16, 17 and 18, connected to a suitable source of alternating current, indicated by the transformer winding 19. It is understood that any of the known means may be employed for supporting and imparting vertical movement to these electrodes.

The heating coils 10 and 11 are excited from two transformers 20 and 21. The magnetic field, in addition to the induction heating effect, is believed to cause a magnetic repulsion radially from the inductive cores such that the outer layers of metal in the inductive loops are forced upward and outward, and are replaced by metal flowing down the insides of the loops. This motive effect enables a rapid circulation of the metal when a high power input is supplied to the windings. The loop channels 8 and 9 gradually expand as they extend upward into the main chamber of the furnace.

The refractory material of the inductive loops is reinforced on the outside by a metallic casing 22.

