

EUROPEAN QUALIFYING EXAMINATION 2007

PAPER A ELECTRICITY / MECHANICS

This paper comprises:

- | | |
|------------------------|---------------------|
| * Client's Letter | 2007/A(E/M)/e/1-6 |
| * Client's Drawings | 2007/A(E/M)/e/7-11 |
| * Document D1 | 2007/A(E/M)/e/12-13 |
| * Drawings Document D1 | 2007/A(E/M)/e/14 |

Client's letter

From: Mr. Olaf Bergamot
T-4-U Co.

To: Earl Grey
European Patent Attorney

Dear Earl Grey,

Our company is specialised in the production of infusion packages for preparing infusion beverages such as tea. These infusion packages comprise substantially flat infusion bags. Two examples of conventional infusion packages 1 are shown in Figs. 1 and 2.

Fig. 1A is a plan view of the first example. Fig. 1B is a cross section along line B-B of Fig. 1A. To produce an infusion bag 2, tea or other infusible substance 9 is placed on a first sheet 5B of flexible liquid-permeable material and a second sheet 5A of the same material is laid on top so that it covers the infusible substance 9. The two sheets 5A, 5B are then bonded together at borders thereof such that a surrounding flange 4 is formed. In this way a closed infusion bag 2 is obtained. Bonding can for example be achieved by gluing or heat sealing. Subsequently a string 3 is stapled or glued to the flange 4. A tag 8 is fixed to the free end of string 3.

The second example is shown in Figs. 2A (plan view) and 2B (cross section along B-B of Fig. 2A). An infusion bag 2 is produced from a single sheet 5 of flexible liquid-permeable material. An infusible substance 9 and an end portion of a string 3 which is provided with a knot 6 are arranged on a first half of sheet 5. Then sheet 5 is folded such that its second half covers the infusible substance 9 and the end portion of string 3. The two superposed layers of sheet 5 are then bonded together such that the infusion bag 2 is closed along a flange 4. A narrow section of the flange is left unbonded to form a straight passageway for the string 3. The knot 6 prevents the end portion of string 3 from slipping out of the infusion bag 2. This way of manufacturing the infusion package is very convenient since the attachment of the string to the infusion bag is carried out during the production of the infusion bag. By contrast, in the first example (Figs. 1A and 1B), subsequent manufacturing steps are necessary to attach the string after the infusion bag has been made.

After an infusion beverage has been prepared in a cup, a teaspoon is normally used to squeeze the infusion bag between the teaspoon and the internal wall of the cup. This is done to extract maximum flavour and to avoid that liquid dripping from the infusion bag stains the table. The infusion bag may also be squeezed by placing it on the teaspoon and winding the string around it. In both cases, a certain skill is needed to do this without upsetting the cup or dropping the infusion bag.

In order to overcome these difficulties we developed infusion packages as shown in Figs. 3 and 4 which we have already been selling for some years. These infusion packages also comprise infusion bags as described above. However, in these infusion packages the string forms a loop around the infusion bag to facilitate squeezing of the infusion bag.

Fig. 3A shows an infusion package 1 having an infusion bag 2 which is immersed in a cup of hot water. A string 3 extends to a flange 4 at the top of the infusion bag where it is guided by a staple 10. Then it passes under the infusion bag and back to the top of the infusion bag where it is fixed to the flange 4 by a further staple 11.

As shown in Fig. 3B, a user can squeeze the infusion bag 2 by pulling the string 3 in the direction of the arrow whilst retaining the infusion bag with his fingers.

Figs. 4A and 4B show an infusion package 1 where the string 3 is arranged differently. As described below, liquid can be squeezed from the infusion bag 2 without the user having to come into contact with it with his fingers.

The string 3 extends from a tag 8 to a first point of a flange 4 at the top of the infusion bag where it is guided by a staple 10. Then it extends to a second point of the flange 4 where it is guided in a notch 7 and thereby coupled to the flange. At notch 7 the string 3 passes under the infusion bag and then back to the top of the infusion bag where it is guided by the staple 10 at the rear of the flange 4. The two points of the flange 4 are in such a way coupled by the string and so located that by pulling the string portions 3A and 3B in opposite directions, the infusion bag 2 is compressed as shown in Fig. 4B.

A problem encountered with these known infusion packages is that it is difficult to retain the string in the correct position. Even the guidance provided by the notch 7 of the infusion bag of Figs. 4A and 4B is not very reliable. If the string becomes displaced, squeezing of the infusion bag becomes less efficient or even impossible. Furthermore, the string portions extending around the infusion bag increase the risk of the string becoming entangled.

My invention concerns infusion packages which are improved with regard to these aspects. I will now describe these infusion packages with reference to the figures 5 to 9.

Fig. 5A shows a perspective view of a first example of an infusion package 1 of my invention. A string 3 enters an infusion bag 2 at point 12 and exits at point 16. Straight passageways for the string are located at these points of the flange 4. The string 3 extends within the interior of the infusion bag 2 from point 12 successively to points 13, 14, 15 and finally to point 16. Points 13 to 15 are internal redirection points for the string 3. U-shaped passageways for the string are located at these points of the flange 4. At all the points 12 to 16, the string 3 is guided in the flange and thereby coupled to the flange. The free ends of the string 3 are fixed to tag portions 8A, 8B of a tag 8 which are joined to each other along a perforated line 20.

Fig. 5B illustrates how the infusion bag 2 is compressed. The tag 8 has to be torn along the perforated line to separate the two tag portions 8A, 8B. The tag portions 8A, 8B are then pulled in opposite directions as indicated by the arrows. The string 3 slides through the passageways at points 12 to 16 of the flange 4. Thus the length of the string portion inside the infusion bag is reduced and the infusion bag is compressed.

The squeezing of the infusion bag can be further improved by providing more internal redirection points. In this way a more uniform compression of the infusion bag can be achieved.

A further advantage of my invention is that the infusion packages can be manufactured substantially in the same way as outlined above for the infusion package of Fig. 2. An infusible substance and a string are appropriately arranged on a first layer of sheet material. Then the infusible substance and the string are covered with a second layer of sheet material. Finally the two layers of sheet material are bonded together at borders thereof such that a flange is formed and a closed infusion bag is obtained. During this bonding operation, straight and U-shaped passageways for the string are formed by leaving appropriate sections of the flange unbonded.

Consequently, attaching the string to the infusion bag does not require a subsequent manufacturing step. By contrast, for the infusion packages shown in Figs. 3 and 4, subsequent manufacturing steps as well as staples are necessary to attach the string to the previously closed infusion bag.

Fig. 6 is a plan view of an improved version of the infusion package of Fig. 5A. As shown in Fig. 6, slack portions 23, 24 of the string 3 are provided within the infusion bag 2. The tag portions 8A, 8B are not only joined to each other along perforated line 20 but are additionally joined to infusion bag 2 along perforated line 21. This provides a compact infusion package and ensures that tangling of the string is avoided.

Figs. 7 to 9 show further examples of my invention.

Fig. 7 shows an infusion package 1 having a circular shaped infusion bag 2 with a flange 4. A string 3 enters the infusion bag 2 at point 12, extends to internal redirection points 13, 15 and exits infusion bag 2 at point 16.

Fig. 8 shows an infusion package 1 having an infusion bag 2 and two strings 3 and 3'. The first string 3 enters the infusion bag at point 12 and the second string 3' enters the infusion bag at point 16. Strings 3 and 3' cross each other in the infusion bag 2. The strings 3 and 3' are fixed in the flange 4 at points 17 and 18 respectively. Fixing of the strings is achieved during the above mentioned bonding operation.

In the examples of Figs. 5 to 8 the infusion bags are compressed by pulling two string portions in opposite directions.

Fig. 9 illustrates a very simple example of my invention. A string 3 enters an infusion bag 2 at a first point 12 of a flange 4 through a straight passageway. It then extends through the interior of the infusion bag and exits the infusion bag at a second point 16 of the flange 4 at which it is guided in a further straight passageway. A knot 6 prevents the end of string 3 from slipping into the infusion bag. In an alternative example (not shown), the end of the string is fixed in the flange at the second point. In both examples the string is guided at the first point of the flange and coupled to the flange at the second point of the flange, the two points being located such that by pulling the string 3 the infusion bag 2 can be compressed. Whilst pulling the string, the infusion bag should be retained, for example with the fingers as described above with reference to Fig. 3B.

I enclose a copy of the patent D1 granted to one of our competitors. D1 also concerns an infusion package having an infusion bag which can be squeezed out in a comfortable way.

I wish to obtain a European Patent protecting my infusion packages and the method of manufacturing them. I hope that the above information will help you to draft an appropriate European Patent Application.

Yours sincerely,

Olaf Bergamot

Client's drawings

1/5

Prior art

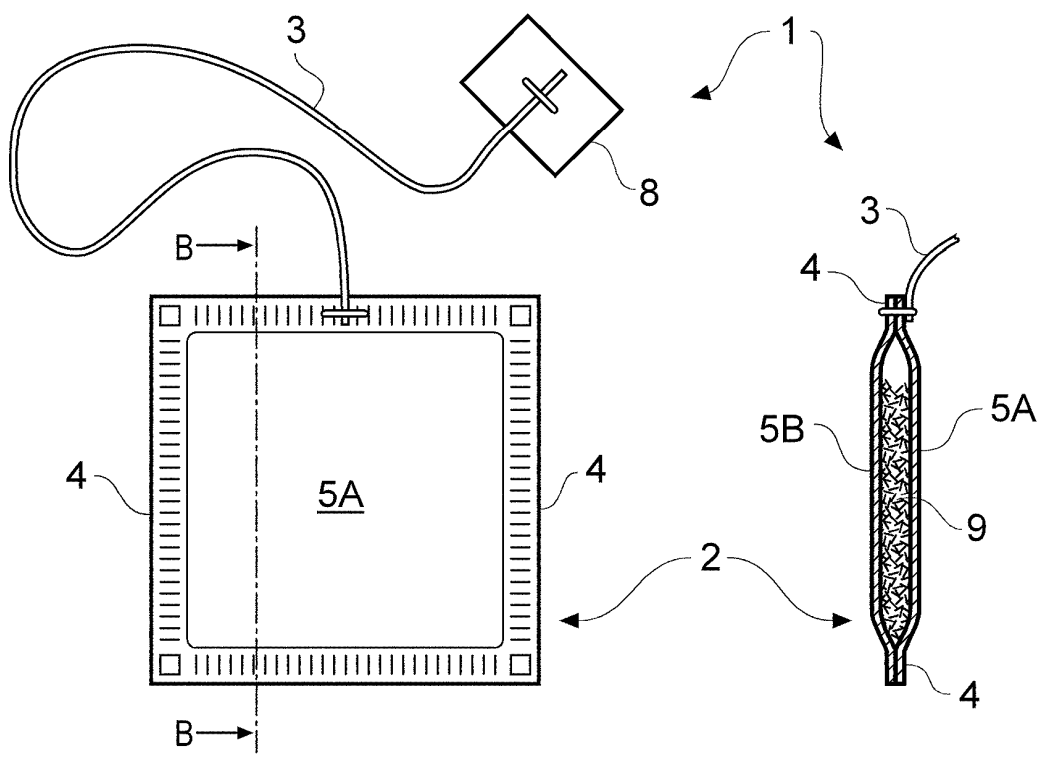

Fig. 1A

Fig. 1B

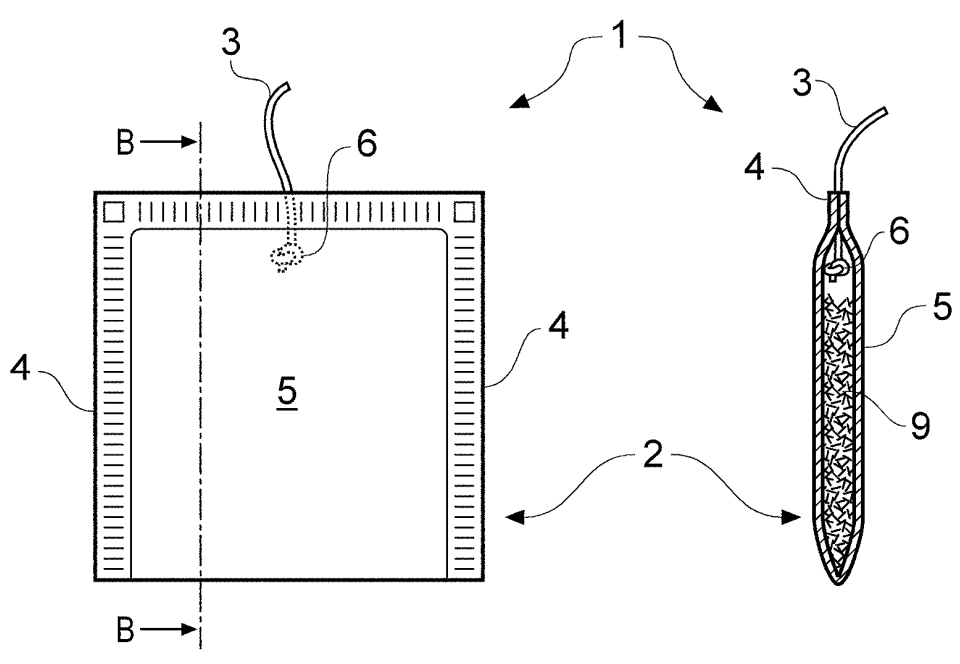

Fig. 2A

Fig. 2B

Prior art

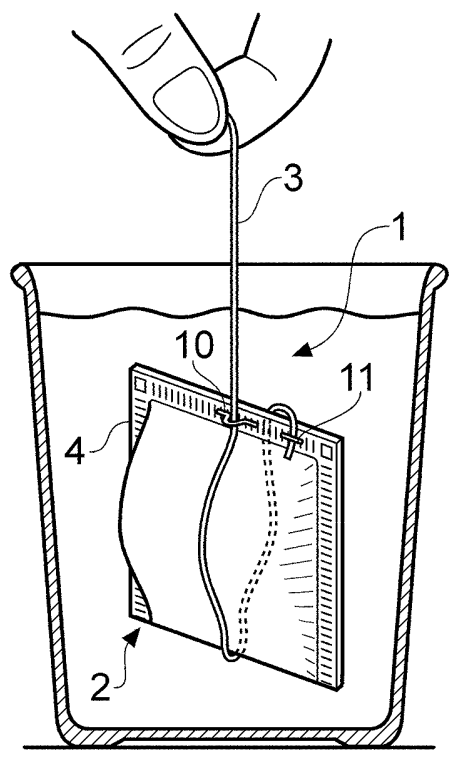

Fig. 3A

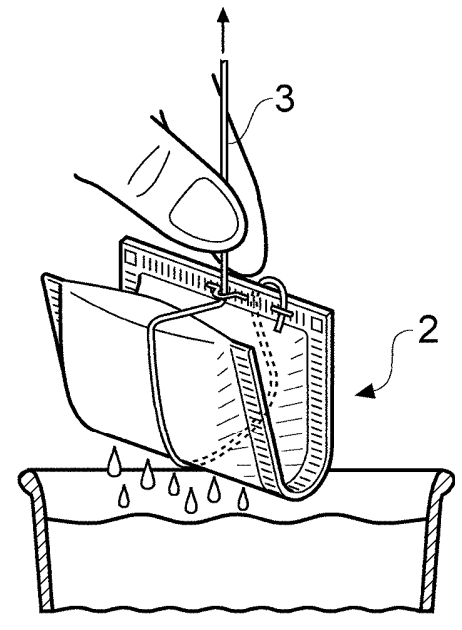

Fig. 3B

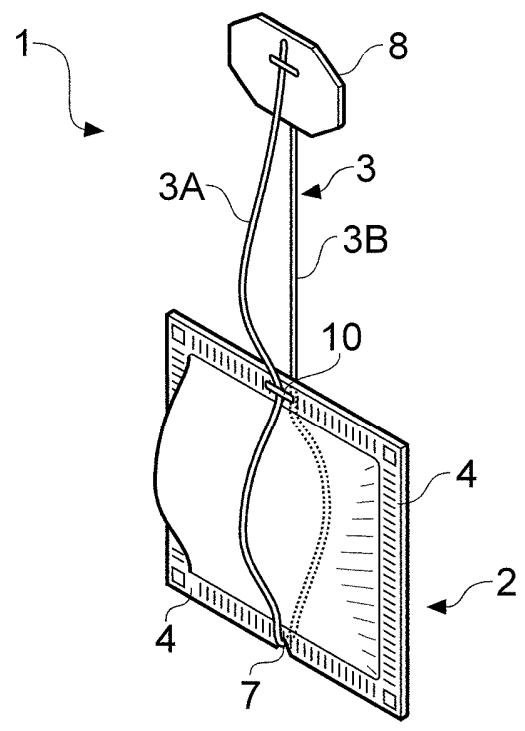

Fig. 4A

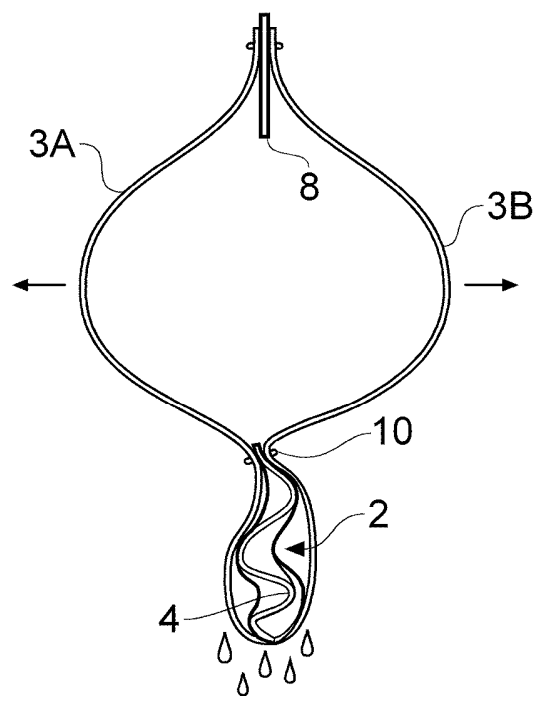

Fig. 4B

3/5

Fig. 5A

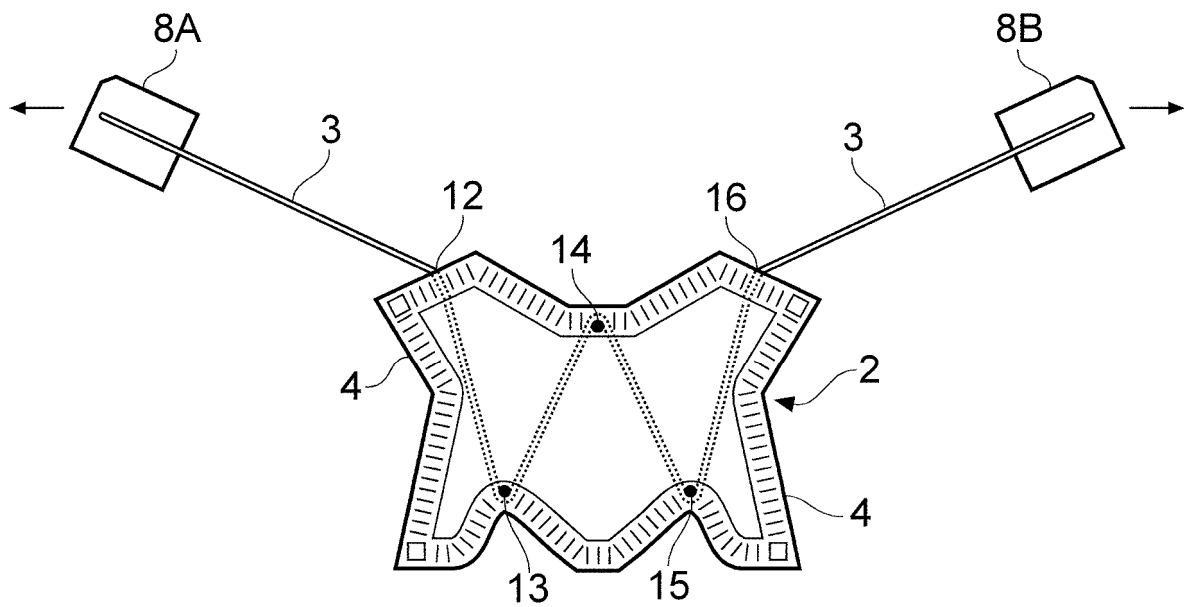
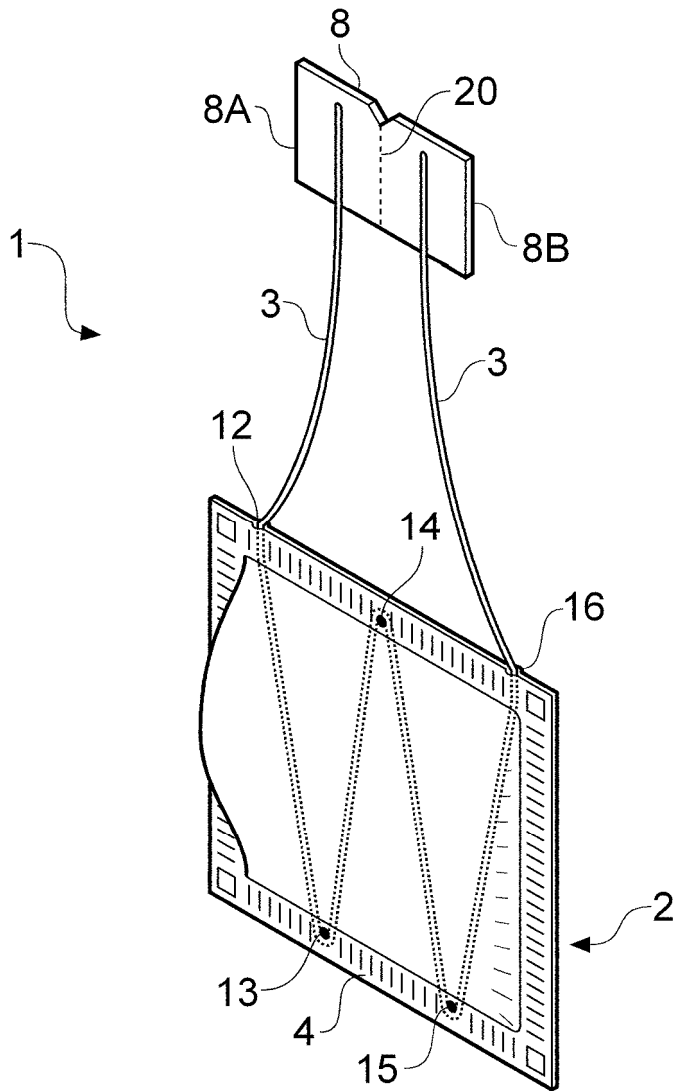

Fig. 5B

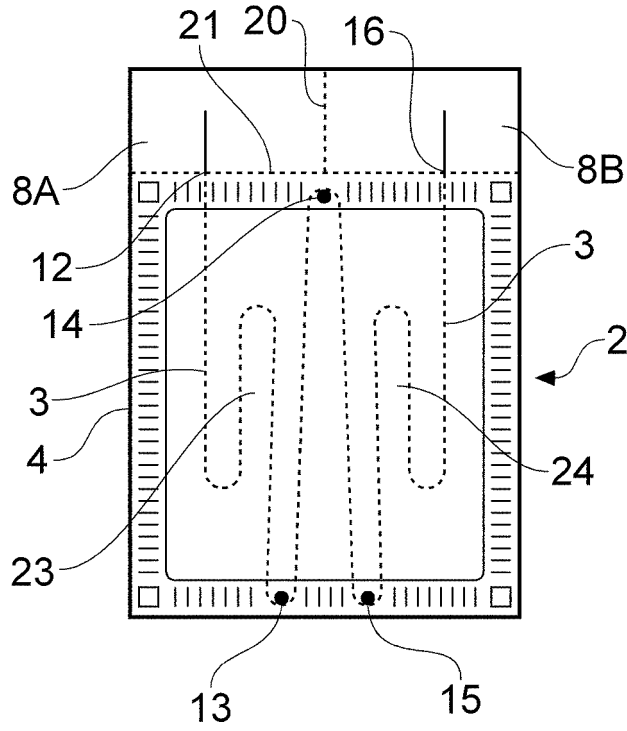

Fig. 6

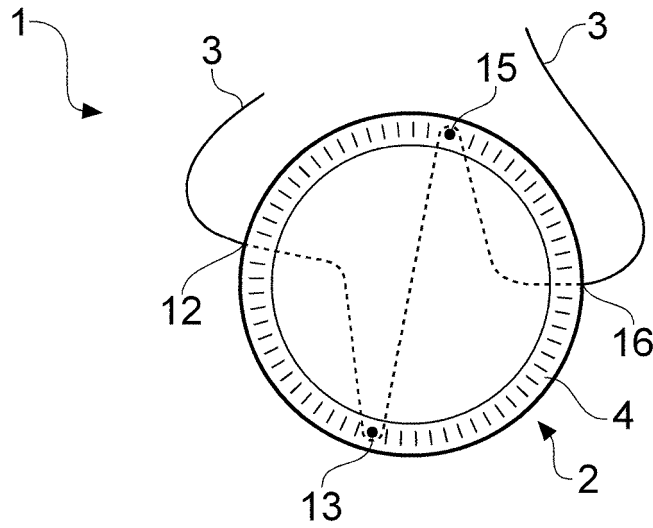

Fig. 7

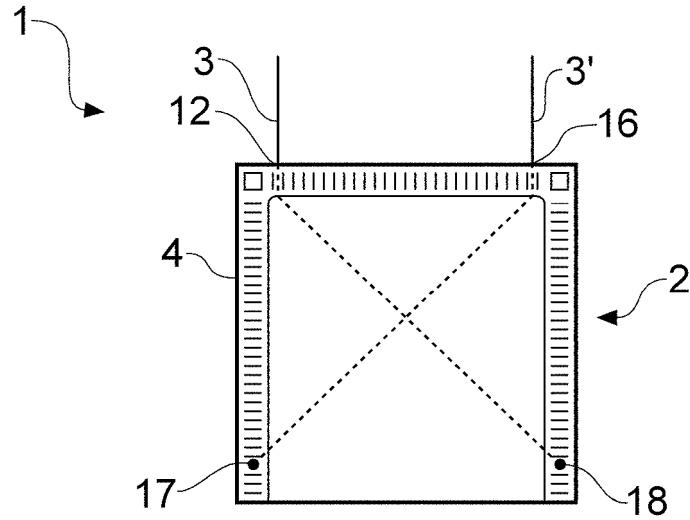

Fig. 8

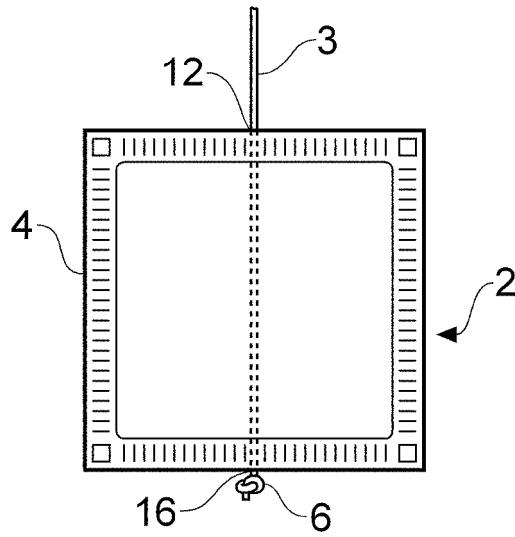

Fig. 9

Document D1

It is difficult to squeeze out the liquid remaining in a conventional tea bag after the tea has been prepared.

5

The present invention provides an improved tea bag which enables a more comfortable handling.

10

Fig. 1 is a plan view of a tea bag according to the invention. Fig. 2 is a cross section along line II-II of Fig. 1.

15

A tea bag 30 is made from a sheet 50 of liquid permeable material and sealed by a flange 40. Two strings 36 and 37 are attached to the tea bag. The free ends of the strings 36 and 37 are fixed to tags 38A and 38B. The tags 38A and 38B may be joined to each other along a perforated line.

20

The tea bag 30 is provided with four pairs of holes (for example the pair 32A, 32B) for guiding the strings. The holes of a pair are respectively arranged in opposite side walls of the tea bag and are coupled by one of the strings. Starting from the tag 38B, the first string 36 passes through the tea bag via the first pair of holes 32B, 32A and is looped around the tea bag. It then again passes through the tea bag via the second pair of holes (of which only hole 33A is shown) and finally extends to the tag 38A. Starting from the tag 38A, the second string 37 passes through the tea bag via the third pair of holes (of which only hole 34A is shown) and is looped around the tea bag. It then again passes through the tea bag via the fourth pair of holes (of which only hole 35A is shown) and finally extends to the tag 38B.

25

After the tea has been prepared, the user pulls tags 38A and 38B in opposite directions. The holes are located such that both the lengths of the string portions which are inside the tea bag 30 and the lengths of the string portions which are looped around the tea bag 30 are then reduced and the tea bag is compressed.

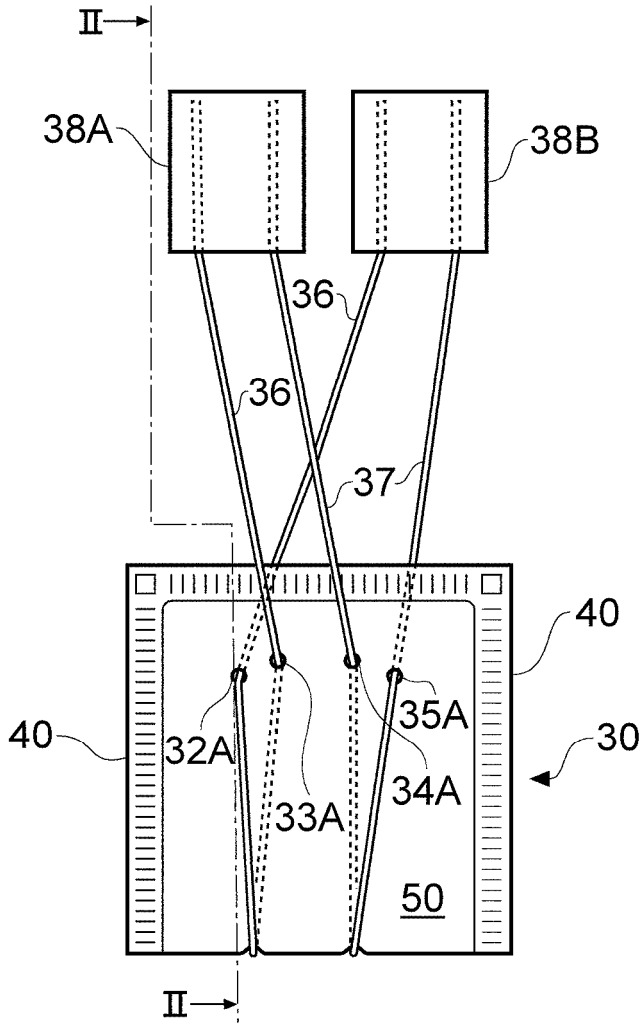
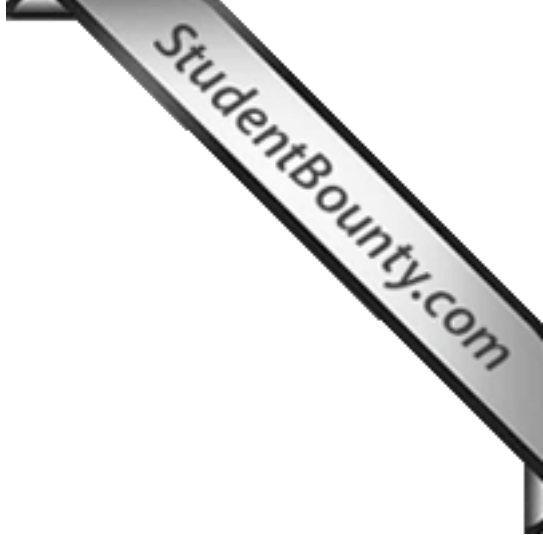

Fig. 1

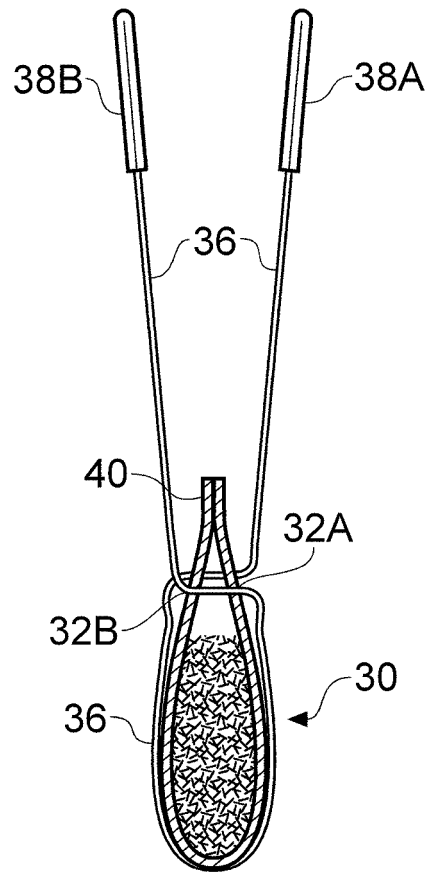

Fig. 2