



Oxford Cambridge and RSA

Wednesday 15 January 2020 – Morning

Level 3 Cambridge Technical in IT

05839/05840/05841/05842/05877 Unit 3: Cyber security

INSERT



INSTRUCTIONS

- Do **not** send this Insert for marking. Keep it in the centre or recycle it.
- This Insert contains the pre-release material that you have already seen.

INFORMATION

- This document has **4** pages.

Fairest Physiotherapy

Introduction

Fairest Physiotherapy is a company which provides physiotherapy, rehabilitation and sports injury assessments services to patients. It has clinics throughout the UK and a central administrative office in Coventry that hosts its IT Services.

Network setup

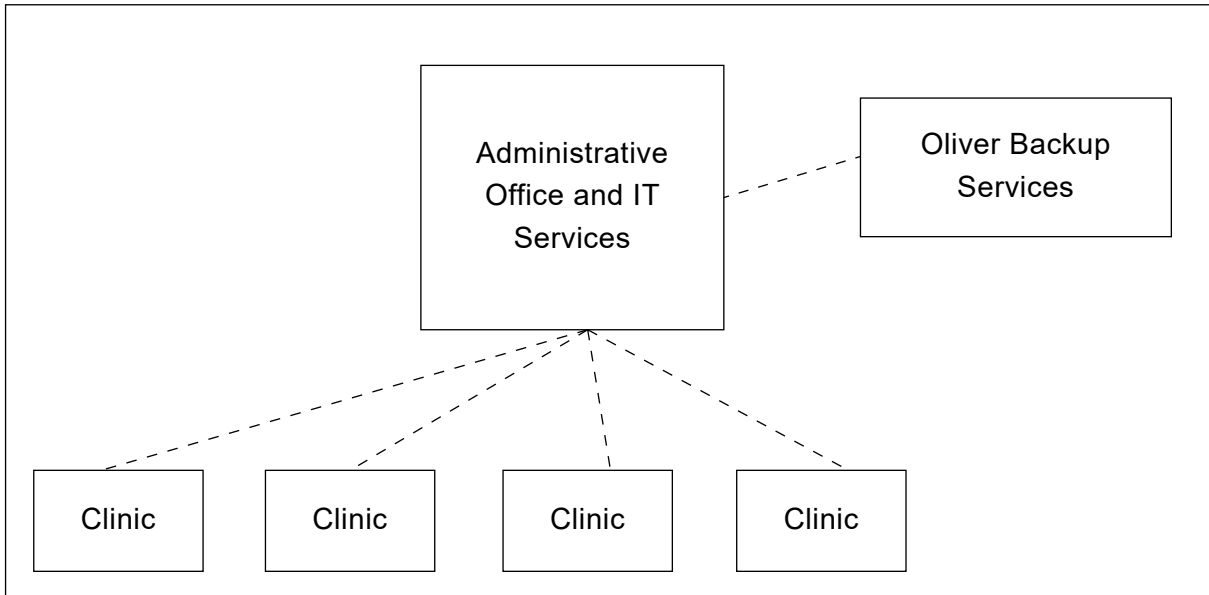

Internet connection

The clinics are connected to the Administrative Office through the internet.

Fairest Physiotherapy has outsourced its backup provision to Oliver Backup Services. The backup is an incremental backup that is completed every night, over a separate internet connection.

One of the tasks of IT Services is to host a database containing customer records, customer appointments and employee data.

Setup within clinics

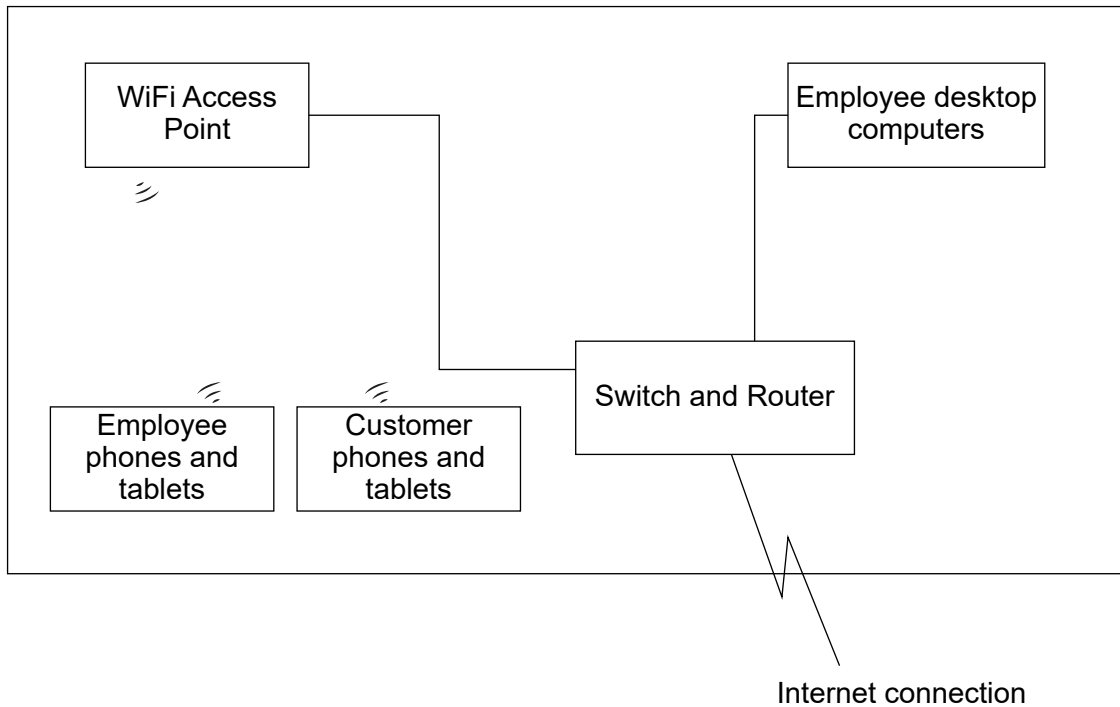

Each clinic is set up in the same way. The employees have wireless access to the system and the internet, whilst customers have wireless access to the internet.

Every employee is given an ID card that doubles up as a RFID card to allow them access to the clinic, and various rooms within the clinic depending on their job requirements.

Cyber security review

A cyber security review has taken place that has identified the following points:

- the company is not fully prepared for system attacks, physical threats or environmental threats
- the company has been mentioned on several forums known to be frequented by hackers as a possible target
- the company has no measures in place for dealing with the impact of a cyber attack on its business.

The recommendations of the cyber security review are that an immediate survey needs to be conducted, looking at how Fairest Physiotherapy could be attacked and how to prevent it.

Further research

To prepare for the examination, you should research the following themes:

- the different types of attacks and threats that Fairest Physiotherapy is vulnerable to
- the motivations that hackers might have for attacking Fairest Physiotherapy
- the impact of a cyber attack on Fairest Physiotherapy
- how the impact of a cyber attack on Fairest Physiotherapy could be reduced.

You should also conduct a risk assessment on Fairest Physiotherapy looking at the most likely areas that could be hacked.



Oxford Cambridge and RSA

Copyright Information:

OCR is committed to seeking permission to reproduce all third-party content that it uses in its assessment materials. OCR has attempted to identify and contact all copyright holders whose work is used in this paper. To avoid the issue of disclosure of answer-related information to candidates, all copyright acknowledgements are reproduced in the OCR Copyright Acknowledgements Booklet. This is produced for each series of examinations and is freely available to download from our public website (www.ocr.org.uk) after the live examination series.

If OCR has unwittingly failed to correctly acknowledge or clear any third-party content in this assessment material OCR will be happy to correct its mistake at the earliest possible opportunity.

For queries or further information please contact the Copyright Team, OCR (Oxford Cambridge and RSA Examinations), The Triangle Building, Shaftesbury Road, Cambridge CB2 8EA.

OCR is part of the Cambridge Assessment Group. Cambridge Assessment is the brand name of University of Cambridge Local Examinations Syndicate (UCLES), which is itself a department of the University of Cambridge.