

Monday 6 June 2022 – Afternoon

Level 3 Cambridge Technical in Engineering

05822/05823/05824/05825/05873 Unit 3: Principles of mechanical engineering

Time allowed: 1 hour 30 minutes

C303/2206



You must have:

- the Formula Booklet for Level 3 Cambridge Technical in Engineering (inside this document)
- a ruler (cm/mm)
- a scientific calculator



Please write clearly in black ink.

Centre number

--	--	--	--	--

Candidate number

--	--	--	--

First name(s)

Last name

Date of birth

D	D	M	M	Y	Y	Y	Y
---	---	---	---	---	---	---	---

INSTRUCTIONS

- Use black ink. You can use an HB pencil, but only for graphs and diagrams.
- Write your answer to each question in the space provided. If you need extra space use the lined pages at the end of this booklet. The question numbers must be clearly shown.
- Answer **all** the questions.
- Where appropriate, your answer should be supported with working. Marks might be given for using a correct method, even if your answer is wrong.
- Give your final answers to a degree of accuracy that is appropriate to the context.
- The acceleration due to gravity is denoted by $g \text{ m s}^{-2}$. When a numerical value is needed use $g = 9.8$ unless a different value is specified in the question.

INFORMATION

- The total mark for this paper is **60**.
- The marks for each question are shown in brackets [].
- This document has **16** pages.

ADVICE

- Read each question carefully before you start your answer.

FOR EXAMINER USE ONLY	
Question No	Mark
1	/11
2	/9
3	/10
4	/13
5	/10
6	/7
Total	/60

Answer **all** the questions.

- 1 (i) A standard concrete brick is a cuboid with dimensions $215 \times 102.5 \times 65$ mm.
The density of concrete is 2100 kg m^{-3} .
Calculate the mass of **one** concrete brick.

.....
.....
.....
.....
..... [4]

- (ii) The bricks are stacked on a pallet ready to be transported.
The coefficient of friction between a brick on the top layer and the layer below it is 0.4.
Calculate the maximum horizontal force allowable before a brick on the top layer can slide relative to the layer below it.

.....
.....
..... [2]

(iii) A wall is built using the bricks.

Fig. 1 shows the side elevation view of the wall aligned within a coordinate system, (x, y) , with the origin at point O.

All dimensions shown are in metres.

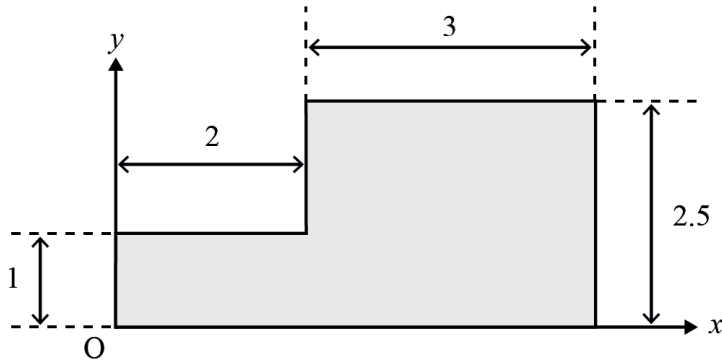

Fig. 1

Calculate the x -coordinate and the y -coordinate of the centroid of the side elevation.

.....
.....
.....
.....
.....
.....
.....
.....
.....
.....
.....
..... [5]

2 (a) **Fig. 2** shows a design of a base-plate.

All dimensions shown are in millimetres.

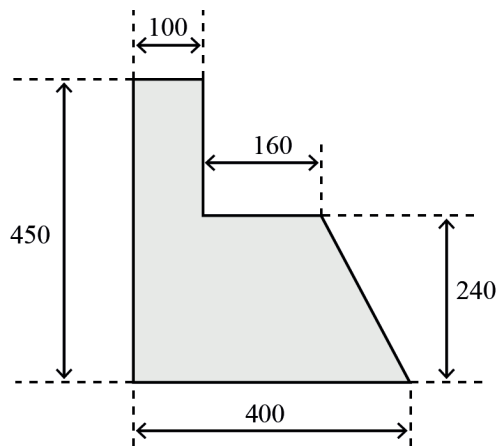

Fig. 2

(i) Calculate the area of this plate.

Give your answer in units of square millimetres.

.....

.....

.....

..... [2]

(ii) Convert your answer from part (i) into units of square centimetres.

.....

..... [1]

- (b) An engineer is using a machine that applies an axial compressive force to a cylindrical titanium rod.

During testing the rod is subjected to a range of stress values within the elastic limit and a graph of stress against strain is produced.

The engineer calculates that the gradient of the graph remains constant with a value of 114 GPa.

- (i) State what is represented by the gradient of this graph.

..... [1]

- (ii) Calculate the strain in the titanium rod when it is subjected to a stress of 600 MPa.

.....
.....
.....
..... [2]

- (iii) When the stress in the rod is 600 MPa, its diameter is measured as 12.2 mm.
Calculate the force that was applied by the machine.
State the units in your answer.

.....
.....
.....
.....
.....
..... [3]

- 3 (a) **Fig. 3** shows a diagram of a lever used to lift a load of 500 N. It has a Mechanical Advantage (MA) of 0.64. The input force, F_i , is x m from the load and 0.55 m from the fulcrum.

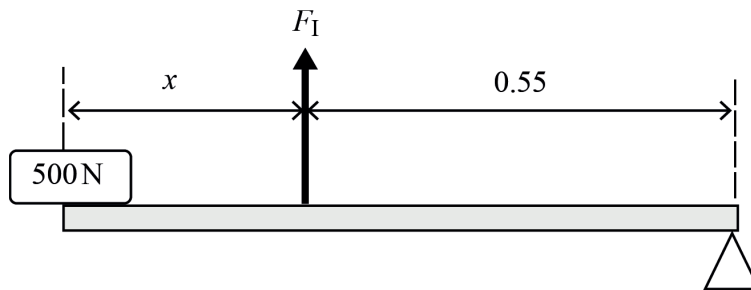

Fig. 3

- (i) State the class of lever shown.

..... [1]

- (ii) Calculate the minimum value of the input force required to lift the load.

.....

 [2]

- (iii) Calculate the distance x .

.....

 [2]

(b) A compound spur gear system is shown in **Fig. 4**.

Gear A is the input gear with 40 teeth and gear D is the output gear with 30 teeth. Gear B has 20 teeth and rotates on the same shaft as gear C which has 10 teeth. Gear A meshes with gear B and gear C meshes with gear D.

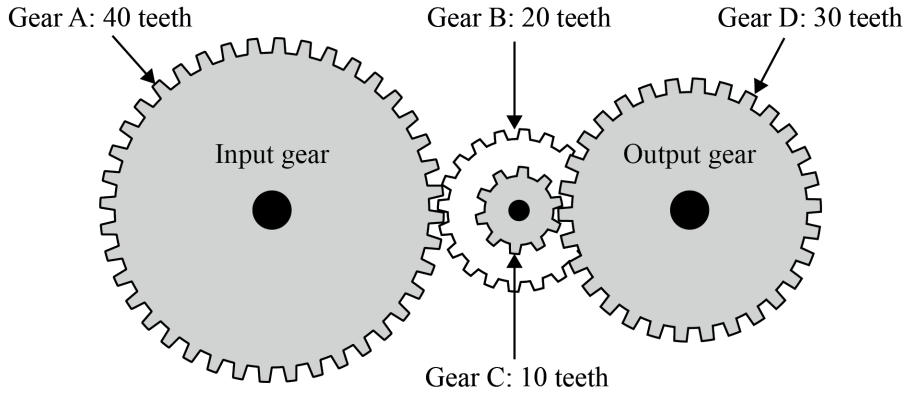

Fig. 4

(i) Calculate the overall Velocity Ratio (VR) of this system.

.....
.....
.....
.....
.....
..... [3]

(ii) Calculate the Mechanical Advantage (MA) of this system.

.....
..... [1]

(iii) A gear can be inserted into this system to cause the output gear to rotate in the opposite direction to the input gear while keeping the overall Velocity Ratio the same. Name this type of gear.

..... [1]

- 4 **Fig. 5** shows a diagram of a trolley used to transport components around a factory. The trolley has a mass of 40 kg, while the mass of the load varies. The total normal reaction force of the floor on the trolley is R N. The trolley is being pushed with a horizontal force of P N. There is also a resistance force, F N = $0.2 \times R$ N acting in the opposite direction to P .

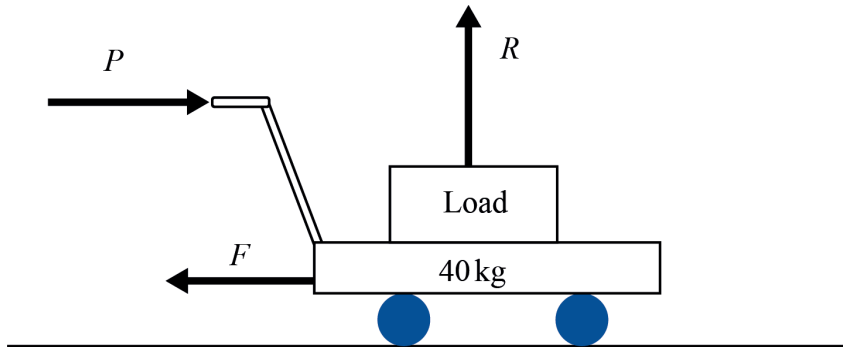

Fig. 5

- (i) Calculate the value of the resistance force F on the trolley when it is carrying a load of 80 kg.

.....

 [2]

- (ii) Calculate the maximum load that the trolley can carry so that it will start to move when pushed with a force of 450 N.

.....

 [3]

The magnitude of P is changed such that the trolley now has a constant acceleration of 0.082 m s^{-2} .

The load is again 80 kg.

- (iii) Calculate the magnitude of the pushing force P .

.....
.....
.....
..... [3]

- (iv) Assuming that the trolley starts from rest calculate the time it would take for it to reach a speed of 0.65 m s^{-1} .

.....
.....
..... [2]

- (v) Calculate the work done by the person pushing the trolley during this period.

.....
.....
.....
.....
..... [3]

- 5 Fig. 6 shows a rigid body with corners A, B, C and D that is subjected to three co-planar forces with magnitudes 150 N, 300 N and 200 N.

All dimensions shown are in metres.

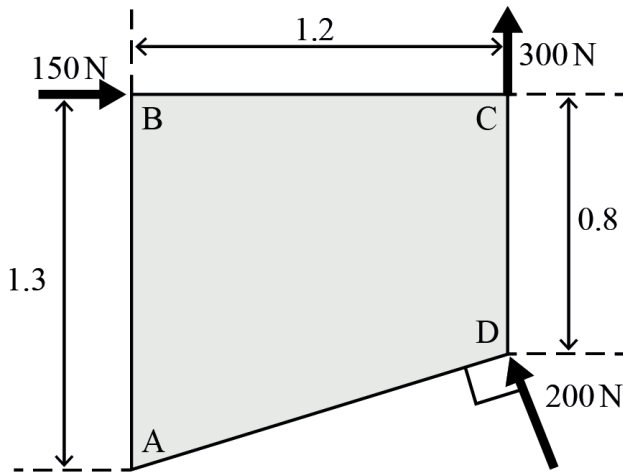

Fig. 6

- (i) Calculate the length of the side AD.

.....

 [2]

- (ii) Calculate the moment around corner A.

.....

 [3]

- (iii) Calculate the magnitude of the resultant force acting on the rigid body.

.....

 [5]

6 (a) State the type of support that is found at each end of an encastre beam.

..... [1]

(b) For a simply-supported beam, name the type of support that can provide a vertical reaction force, no horizontal reaction force, and no moment.

..... [1]

(c) **Fig. 7** shows a simply-supported beam of length 12 m with supports A and B. The beam is subjected to two vertical point loads with magnitudes 12000 N and 15000 N and a uniformly-distributed load of 2000 N m⁻¹.

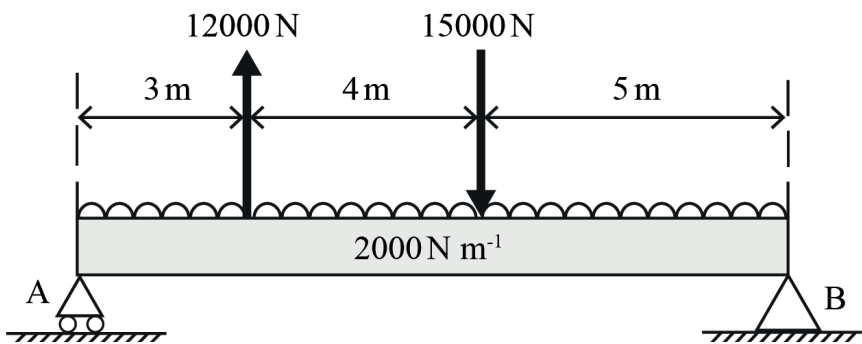

Fig. 7

Calculate the magnitude of the reaction forces at the supports A and B.

.....
.....
.....
.....
.....
.....
.....
.....
.....
.....
.....
.....
.....
.....
.....
.....
.....
.....
.....
..... [5]

END OF QUESTION PAPER

ADDITIONAL ANSWER SPACE

If additional answer space is required, you should use the following lined pages. The question numbers must be clearly shown – for example, 1(i) or 2(a)(i).

A vertical line on the left side of the page is followed by 25 horizontal dotted lines, providing a ruled area for writing answers.

A series of horizontal dotted lines for writing, spanning the width of the page.

A series of horizontal dotted lines for writing, spanning the width of the page.

A series of horizontal dotted lines for writing, spanning the width of the page.



Oxford Cambridge and RSA

Copyright Information

OCR is committed to seeking permission to reproduce all third-party content that it uses in its assessment materials. OCR has attempted to identify and contact all copyright holders whose work is used in this paper. To avoid the issue of disclosure of answer-related information to candidates, all copyright acknowledgements are reproduced in the OCR Copyright Acknowledgements Booklet. This is produced for each series of examinations and is freely available to download from our public website (www.ocr.org.uk) after the live examination series.

If OCR has unwittingly failed to correctly acknowledge or clear any third-party content in this assessment material, OCR will be happy to correct its mistake at the earliest possible opportunity.

For queries or further information please contact the Copyright Team, OCR (Oxford Cambridge and RSA Examinations), The Triangle Building, Shaftesbury Road, Cambridge CB2 8EA.

OCR is part of Cambridge University Press & Assessment, which is itself a department of the University of Cambridge.

© OCR 2022

C303/2206