

## **CAMBRIDGE TECHNICALS LEVEL 3 (2016)**

*Examiners' report*

# ***ENGINEERING***



## **Unit 3 January 2019 series**

Version 1

# Contents

Introduction .....	3
Unit 3 series overview .....	4
Question 1 (i) .....	5
Question 1 (ii) .....	6
Question 1 (iii).....	6
Question 2 (a)(i).....	7
Question 2 (a)(ii) .....	7
Question 2 (a)(iii) .....	8
Question 2 (b).....	8
Question 2 (c)(i) .....	8
Question 2 (c) (ii) .....	9
Question 2 (c) (iii).....	9
Question 3 (a)(i).....	10
Question 3 (a)(ii) .....	11
Question 3 (b).....	11
Question 4 (i) .....	11
Question 4 (ii) .....	12
Question 4 (iii).....	12
Question 4 (iv) .....	12
Question 4 (v) .....	13
Question 5 (a).....	13
Question 5 (b).....	14
Question 5 (c) .....	14
Question 5 (d)(i).....	14
Question 5(d)(ii) .....	15
Question 5(e) (i).....	15
Question 5(e)(ii) .....	15
Question 6(a) .....	15
Question 6(b)(i).....	16
Question 6(b)(ii) .....	17

## Introduction

Our examiners' reports are produced to offer constructive feedback on candidates' performance in the examinations. They provide useful guidance for future candidates. The reports will include a general commentary on candidates' performance, identify technical aspects examined in the questions and highlight good performance and where performance could be improved. The reports will also explain aspects which caused difficulty and why the difficulties arose, whether through a lack of knowledge, poor examination technique, or any other identifiable and explainable reason.

Where overall performance on a question/question part was considered good, with no particular areas to highlight, these questions have not been included in the report. A full copy of the question paper can be downloaded from OCR.

## Unit 3 series overview

Unit 3 paper appeared to be accessible with most candidates attempting all the questions. There is some improvement in candidates' working for calculation questions, however some candidates struggle to use the correct engineering language in written answers. Some centres seem to be learning from the preceding Unit 3 examinations and preparing candidates well for recurring topics. However, many candidates continue to score low or sometimes zero marks on some topics.

<b><i>Candidates who performed well, tended to:</i></b>	<b><i>Candidates who did less well tended to:</i></b>
<ul style="list-style-type: none"><li>• use appropriate engineering language</li><li>• show clear working in all calculations</li><li>• remember to convert units into standard units before carrying out any calculation.</li></ul>	<ul style="list-style-type: none"><li>• make careless mistakes in calculations</li><li>• use incorrect engineering language</li><li>• score low marks on some recurring topics.</li></ul>

### Question 1 (i)

- 1 An aluminium plate with a uniform thickness of 5 mm comprises a semi-circular section with a radius of 50 mm and a rectangular section with a length of 120 mm and a width of 40 mm. The plate, OABCD, is shown in Fig. 1 aligned within a Cartesian coordinate system,  $(x, y)$  with the origin at corner O.

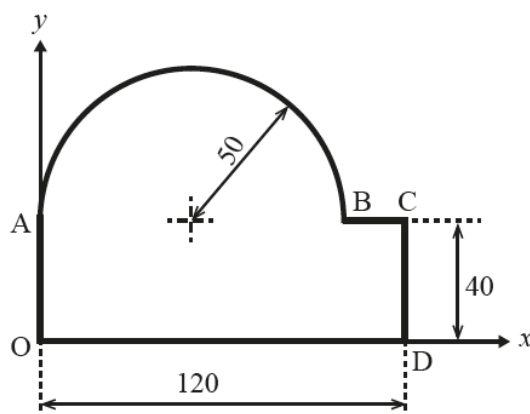

Fig. 1

- (i) The density of the aluminium plate is  $2700 \text{ kg m}^{-3}$ . Calculate the mass of the plate.

.....

.....

.....

..... [5]

This question requires candidates to calculate the combined area of a semi-circle and a rectangle. The correct area value is converted to consistent units and multiplied by thickness to find volume. The correct volume is multiplied by density to find the mass. Most candidates scored 1 or 2 marks for calculating area but many candidates did not use the thickness correctly to find the volume.

### Question 1 (ii)

(ii) Calculate the coordinates of the centroid of the plate.

.....  
.....  
.....  
..... [5]

A question of this type has appeared in each of the previous Unit 3 examination papers. Many candidates used a tabular approach to present the key steps in their working, including areas and coordinates of centroids of each shape. These candidates had clearly used the moment of area method and most scored at least 3 marks. Most of these candidates went on to divide the sum of the moments of area by the total area to calculate the coordinates of the centroid.

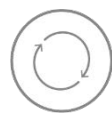

**AfL**

Encourage candidates use a moment of area method to find coordinates of centroid and to use a tabular format to show workings clearly.

### Question 1 (iii)

(iii) The plate is suspended from corner D. Calculate the angle that side CD makes with the vertical.

.....  
.....  
.....  
..... [2]

Most candidates attempted to use trigonometry (specifically the  $\tan^{-1}$  function) to find the angle but few calculated the angle to the vertical correctly.

**Question 2 (a)(i)**

- 2 (a) Fig. 2 shows a diagram of a compound gear train. The input gear, labelled A, has 100 teeth and the output gear, labelled D, has 120 teeth. The compound gear consists of gears B and C which rotate together on the same shaft. Gear B has 200 teeth and gear C has 80 teeth.

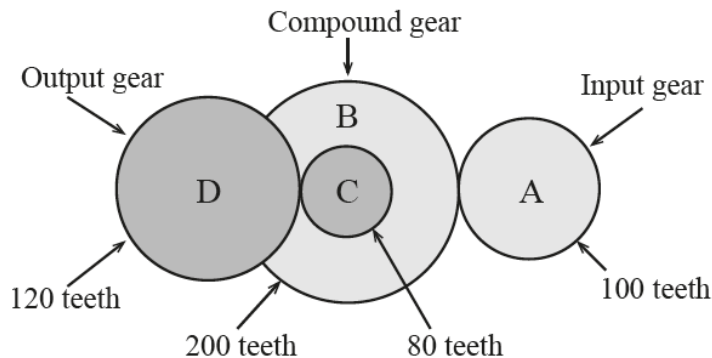

**Fig. 2**

- (i) Calculate the overall Velocity Ratio (VR) of this gear train.

.....  
 .....  
 .....  
 ..... [2]

Most candidates calculated the overall VR correctly using 'product of drivers/product of driven'.

**Question 2 (a)(ii)**

- (ii) The output gear must rotate at a speed of 60 rpm. Calculate the rotation speed of the input gear.

.....  
 ..... [1]

Most candidates calculated the speed of input correctly.

### Question 2 (a)(iii)

(iii) Calculate the Mechanical Advantage (MA) of this gear system.

..... [1]

Most candidates calculated the Mechanical Advantage (MA) correctly.

### Question 2 (b)

(b) A belt and pulley system has a velocity ratio of 1.8. The diameter of the input pulley is 85 cm. Calculate the diameter of the output pulley.

.....  
..... [1]

Most candidates calculated the input diameter correctly.

### Question 2 (c)(i)

(c) Fig. 3 shows a diagram of a lever with a length of 0.8 m. The lever has a fulcrum at one end and an input force,  $F_I$  N, at the other end. A load on the lever is positioned at 0.5 m from the fulcrum.

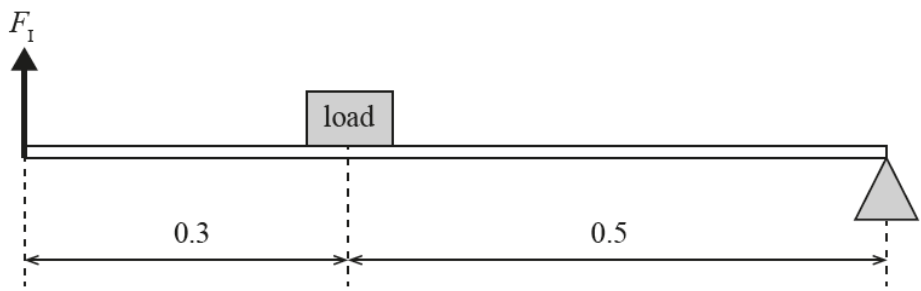

Fig. 3

(i) State the class of lever.

..... [1]

Most correctly identified this as a class 2 lever.



### Question 2 (c) (ii)

(ii) Calculate the Mechanical Advantage of the lever.

.....  
..... [1]

Most calculated the Mechanical Advantage correctly.

### Question 2 (c) (iii)

(iii) A child is attempting to use the lever to lift a load of 30 kg. The maximum input force that the child can apply is 200 N. Determine whether or not the child is able to lift the load. Your answer must be supported by suitable calculations. The mass of the lever can be ignored.

.....  
.....  
.....  
..... [3]

Most candidates calculated the weight correctly and scored at least 1 mark. The most common approach was to calculate and compare the moments of the load and the child about the fulcrum. Many candidates did this correctly. Some candidates used the relationship between input and output forces and MA or found the maximum force the child can lift. Both methods could also score full marks. Most candidates included a clear statement that the child is able to lift the load but some failed to score 3 marks because they omitted such a statement.



#### Misconception

When applying the principle of moments, it is important to identify the point about which moments are taken.

### Question 3 (a)(i)

3 (a) A particle is subjected to three co-planar, concurrent forces, as shown in Fig. 4.

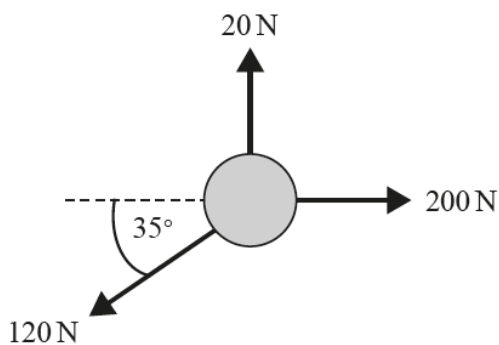

Fig. 4

(i) Calculate the magnitude of the resultant force.

.....  
.....  
.....  
..... [4]

Most candidates did not calculate either the net horizontal or vertical forces correctly. Most of these also did not attempt to use Pythagoras' Theorem to calculate the magnitude of the resultant force (using their values of net forces). However, a significant minority of candidates did calculate both net forces correctly and then found the resultant using Pythagoras' Theorem correctly.



**AfL**

Encourage candidates to gain familiarity with resolving forces in particular directions.

### Question 3 (a)(ii)

- (ii) The particle has a mass of 3 kg, and is acted upon by the forces shown in Fig. 4 for a period of 8 seconds. The initial speed of the particle is  $4 \text{ m s}^{-1}$  in the same direction as the resultant force. Calculate the distance travelled by the particle during the 8 seconds period.

.....  
.....  
.....  
.....  
..... [3]

Most candidates gained some credit by attempting to use the correct 'SUVAT' equation. However, most of these did not use the correct value of acceleration calculated using their answer to 3ai. A common error was to equate acceleration due to gravity.

### Question 3 (b)

- (b) A car travels at a constant speed of  $25 \text{ m s}^{-1}$  for 20 seconds while producing a constant driving force of 3200 N. Calculate the work done by the driving force during this period.

.....  
.....  
..... [2]

Most candidates calculated the 'work done' correctly. Many who did not score full marks scored 1 mark for calculating 'power'.

### Question 4 (i)

- 4 A child pushes a toy go-cart of mass 15 kg along rough horizontal ground by applying a constant horizontal force of 40 N. The coefficient of friction between the ground and the wheels of the go-cart is 0.04.

- (i) Draw a diagram showing all the forces acting on the go-cart.

[2]

Most candidates scored 1 mark. The most common error was to label the friction arrow with the value of the coefficient of friction. The majority of candidates did show 4 arrows with a very small number omitting arrow heads.

### Question 4 (ii)

(ii) Calculate the magnitude of the friction force acting on the go-cart.

.....  
..... [2]

Many candidates scored zero on this question; they seemed to be unaware of the simple formula relating normal reaction and coefficient of friction to frictional force. Some of those who were aware of the relationship did not include the value of  $g$ .

### Question 4 (iii)

(iii) Calculate the acceleration of the go-cart.

.....  
.....  
..... [3]

Most candidates gained some credit for attempting to apply Newton's Second Law but omitting the friction force. Many did include friction and scored full marks.

### Question 4 (iv)

(iv) The child releases the go-cart when it is travelling at a speed of  $2.7 \text{ m s}^{-1}$ . Calculate the kinetic energy of the go-cart at this time.

.....  
..... [1]

Most calculated 'kinetic energy' correctly.

### Question 4 (v)

- (v) After the go-cart has been released, calculate the distance travelled before it comes to rest. Use an energy method and you may assume no other forces act on the go-cart except for friction.

.....

.....

..... [2]

Many calculated the distance correctly using the work-energy relationship.

### Question 5 (a)

- 5 (a) Fig. 5 shows a steel bolt of diameter 8 mm which is in double shear when subjected to a tensile force of 2000 N. Calculate the shear stress in the bolt. You must include appropriate units in your answer.

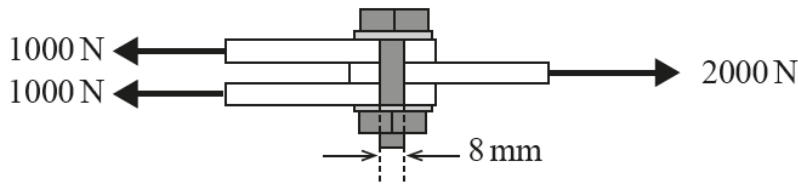

Fig. 5

.....

.....

.....

..... [3]

Most scored at least 1 mark for calculating cross sectional area. Few used this together with the shear force to calculate the shear stress correctly. The most common error was the failure to multiply the area by 2. Many candidates also made mistakes with units.



**AfL**

In double shear stress calculations like this one, the area required is 2 x the bolt cross sectional area.

### Question 5 (b)

(b) Name the term used in engineering that represents the stiffness of material.

..... [1]

Only a small minority wrote 'Young's modulus' (or equivalent).

### Question 5 (c)

(c) A cable has an extension of 6 mm when subjected to a strain of 0.4%. Calculate the original length of the cable.

.....  
..... [2]

Most scored at least 1 mark for using the correct relationship. Many scored both marks by correct conversion of units.

### Question 5 (d)(i)

(d) (i) Name the type of gear system shown in Fig. 6.

..... [1]



Fig. 6

Most identified the type of gear correctly.

### Question 5(d)(ii)

(ii) Name one application of this gear system.

..... [1]

Most candidates gave an appropriate application.

### Question 5(e) (i)

(e) An engineer must decide whether to use a flat belt and pulley system or a chain and sprocket set to transfer rotational motion between two mechanisms.

(i) Name one advantage to using a chain and sprocket set instead of a flat belt and pulley system.

..... [1]

Most candidates gave an appropriate advantage.

### Question 5(e)(ii)

(ii) Name one advantage to using a flat belt and pulley system instead of a chain and sprocket set.

..... [1]

Most candidates gave an appropriate advantage.

### Question 6(a)

6 (a) Name the type of beam shown in Fig. 7.

..... [1]

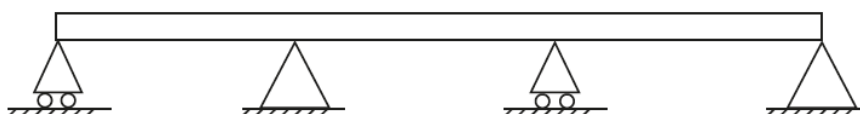

Fig. 7

Only a small minority of candidates identified the type of beam correctly.

### Question 6(b)(i)

- (b) Fig. 8 shows a uniform beam of length 10 m which is simply supported at ends A and B. The beam is subjected to two external forces of 15 000 N and 20 000 N acting vertically downwards at the positions indicated. The self-weight of the beam is represented by a force of 6000 N acting vertically downwards at its centre as shown.

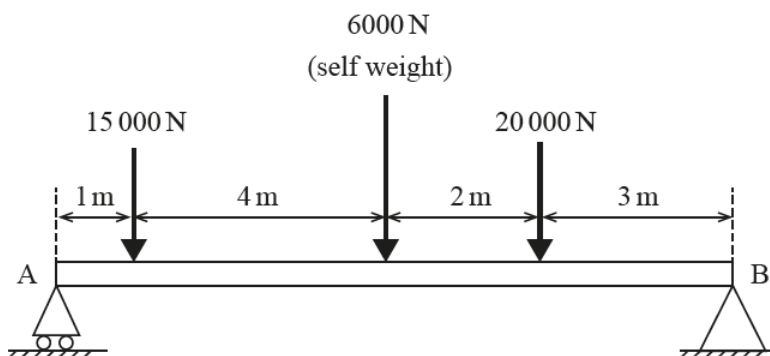

Fig. 8

- (i) Calculate the reaction at the support at end A and the reaction at the support at end B.

.....

.....

.....

.....

..... [4]

A minority of candidates scored high marks (3 or 4) on this question. Candidates mostly scored either 0 or 1 mark. Most candidates did attempt to take moments but common errors included; inconsistency and lack of clarity on which point moments were taken about; omission of the force acting at A or B in their moments expression.



**AfL** Encourage candidates to be familiar applying the principle of moments to problems involving beams.



**Question 6(b)(ii)**

(ii) Draw a labelled bending moment diagram for the beam on the grid below.

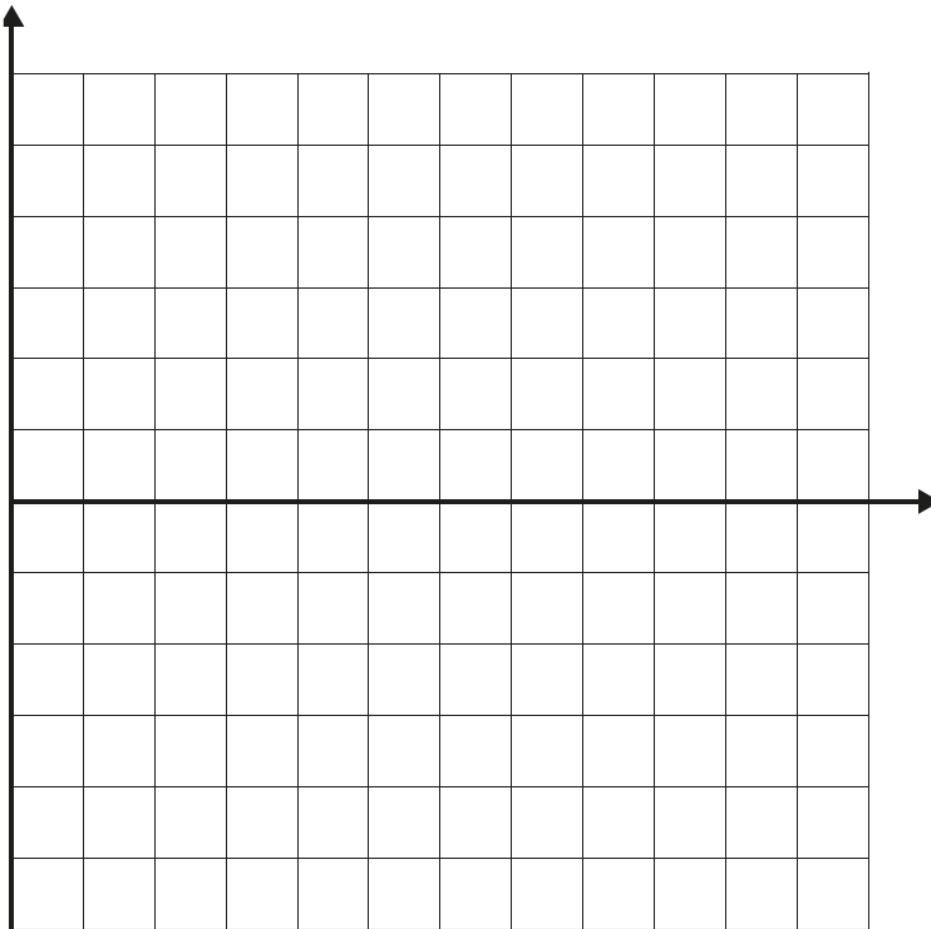

[4]

A minority of candidates scored high marks (3 or 4) on this question. Candidates mostly scored either 0 or 1. It was possible to score 1 mark by showing a linear diagram with moment of 0 at both ends.

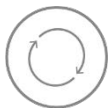
**AfL**

Encourage candidates to be familiar with bending moment diagrams for beams. For beams loaded with point loads, the diagram will be linear.

## Supporting you

For further details of this qualification please visit the subject webpage.

### Review of results

If any of your students' results are not as expected, you may wish to consider one of our review of results services. For full information about the options available visit the [OCR website](#). If university places are at stake you may wish to consider priority service 2 reviews of marking which have an earlier deadline to ensure your reviews are processed in time for university applications.



Attend one of our popular CPD courses to hear exam feedback directly from a senior assessor or drop in to an online Q&A session.

<https://www.cpdhub.ocr.org.uk>



We'd like to know your view on the resources we produce. By clicking on the 'Like' or 'Dislike' button you can help us to ensure that our resources work for you. When the email template pops up please add additional comments if you wish and then just click 'Send'. Thank you.

Whether you already offer OCR qualifications, are new to OCR, or are considering switching from your current provider/awarding organisation, you can request more information by completing the Expression of Interest form which can be found here:

[www.ocr.org.uk/expression-of-interest](http://www.ocr.org.uk/expression-of-interest)

#### **OCR Resources:** *the small print*

OCR's resources are provided to support the delivery of OCR qualifications, but in no way constitute an endorsed teaching method that is required by OCR. Whilst every effort is made to ensure the accuracy of the content, OCR cannot be held responsible for any errors or omissions within these resources. We update our resources on a regular basis, so please check the OCR website to ensure you have the most up to date version.

This resource may be freely copied and distributed, as long as the OCR logo and this small print remain intact and OCR is acknowledged as the originator of this work.

Our documents are updated over time. Whilst every effort is made to check all documents, there may be contradictions between published support and the specification, therefore please use the information on the latest specification at all times. Where changes are made to specifications these will be indicated within the document, there will be a new version number indicated, and a summary of the changes. If you do notice a discrepancy between the specification and a resource please contact us at:

[resources.feedback@ocr.org.uk](mailto:resources.feedback@ocr.org.uk).

OCR acknowledges the use of the following content:  
Square down and Square up: alexwhite/Shutterstock.com

Please get in touch if you want to discuss the accessibility of resources we offer to support delivery of our qualifications:  
[resources.feedback@ocr.org.uk](mailto:resources.feedback@ocr.org.uk)

#### **Looking for a resource?**

There is now a quick and easy search tool to help find **free** resources for your qualification:

[www.ocr.org.uk/i-want-to/find-resources/](http://www.ocr.org.uk/i-want-to/find-resources/)

[www.ocr.org.uk](http://www.ocr.org.uk)

OCR Customer Support Centre

#### **Vocational qualifications**

Telephone 02476 851509

Facsimile 02476 851633

Email [vocational.qualifications@ocr.org.uk](mailto:vocational.qualifications@ocr.org.uk)

OCR is part of Cambridge Assessment, a department of the University of Cambridge. *For staff training purposes and as part of our quality assurance programme your call may be recorded or monitored.*

© **OCR 2019** Oxford Cambridge and RSA Examinations is a Company Limited by Guarantee. Registered in England. Registered office The Triangle Building, Shaftesbury Road, Cambridge, CB2 8EA. Registered company number 3484466. OCR is an exempt charity.



Cambridge  
Assessment



001