

Cambridge Pre-U Specimen Papers
and Mark Schemes

Cambridge International Level 3
Pre-U Certificate in
PHYSICS

For use from 2008 onwards

Cambridge
Pre-U

www.XtremePapers.com



UNIVERSITY of CAMBRIDGE
International Examinations

Specimen Materials

Physics (9792)

Cambridge International Level 3
Pre-U Certificate in Physics (Principal)

For use from 2008 onwards

QAN 500/3684/1

Support

CIE provides comprehensive support for all its qualifications, including the Cambridge Pre-U. There are resources for teachers and candidates written by experts. CIE also endorses a range of materials from other publishers to give a choice of approach. More information on what is available for this particular syllabus can be found at www.cie.org.uk

Syllabus Updates

This booklet of specimen materials is for use from 2008. It is intended for use with the version of the syllabus that will be examined in 2010, 2011 and 2012. The purpose of these materials is to provide Centres with a reasonable idea of the general shape and character of the planned question papers in advance of the first operational examination.

If there are any changes to the syllabus CIE will write to centres to inform them. The syllabus and these specimen materials will also be published annually on the CIE website (www.cie.org.uk/cambridgepreu). The version of the syllabus on the website should always be considered as the definitive version.

Further copies of this, or any other Cambridge Pre-U specimen booklet, can be obtained by either downloading from our website www.cie.org.uk/cambridgepreu

or contacting:

Customer Services, University of Cambridge International Examinations,
1 Hills Road, Cambridge CB1 2EU
Telephone: +44 (0)1223 553554
Fax: +44 (0)1223 553558
E-mail: international@cie.org.uk

CIE retains the copyright on all its publications. CIE registered Centres are permitted to copy material from this booklet for their own internal use. However, CIE cannot give permission to Centres to photocopy any material that is acknowledged to a third party even for internal use within a Centre.

Copyright © University of Cambridge Local Examinations Syndicate 2008



PHYSICS

9792/01

Paper 1 Part A Multiple Choice

SPECIMEN PAPER

1 hour 15 minutes

Additional Materials: Multiple Choice Answer Sheet
 Soft clean eraser
 Soft pencil (type B or HB is recommended)

READ THESE INSTRUCTIONS FIRST

Write in soft pencil.

Do not use staples, paper clips, highlighters, glue or correction fluid.

Write your name, Centre number and candidate number on the Answer Sheet in the spaces provided unless this has been done for you.

There are **forty** questions on this paper. Answer **all** questions. For each question there are four possible answers **A, B, C** and **D**.

Choose the **one** you consider correct and record your choice in **soft pencil** on the separate Answer Sheet.

Read the instructions on the Answer Sheet very carefully.

Each correct answer will score one mark. A mark will **not** be deducted for a wrong answer.

Any rough working should be done in this booklet.

This document consists of **18** printed pages.



Data

gravitational field strength close to Earth's surface	$g = 9.81 \text{ N kg}^{-1}$
elementary charge	$e = 1.60 \times 10^{-19} \text{ C}$
speed of light in vacuum	$c = 3.00 \times 10^8 \text{ m s}^{-1}$
Planck constant	$h = 6.63 \times 10^{-34} \text{ J s}$
permittivity of free space	$\epsilon_0 = 8.85 \times 10^{-12} \text{ F m}^{-1}$
gravitational constant	$G = 6.67 \times 10^{-11} \text{ N m}^2 \text{ kg}^{-2}$
electron mass	$m_e = 9.11 \times 10^{-31} \text{ kg}$
proton mass	$m_p = 1.67 \times 10^{-27} \text{ kg}$
unified atomic mass constant	$u = 1.66 \times 10^{-27} \text{ kg}$
molar gas constant	$R = 8.31 \text{ J K}^{-1} \text{ mol}^{-1}$
Avogadro constant	$N_A = 6.02 \times 10^{23} \text{ mol}^{-1}$
Boltzmann constant	$k = 1.38 \times 10^{-23} \text{ J K}^{-1}$
Stefan-Boltzmann constant	$\sigma = 5.67 \times 10^{-8} \text{ W m}^{-2} \text{ K}^{-4}$

Formulae

uniformly accelerated motion	$s = ut + \frac{1}{2} at^2$
	$v^2 = u^2 + 2as$
	$s = \left(\frac{u+v}{2} \right) t$
heating	$\Delta E = mc\Delta\theta$
change of state	$\Delta E = mL$
refraction	$n = \frac{\sin \theta_1}{\sin \theta_2}$
	$n = \frac{v_1}{v_2}$
photon energy	$E = hf$
de Broglie wavelength	$\lambda = \frac{h}{p}$
simple harmonic motion	$x = A \cos \omega t$
	$v = -A\omega \sin \omega t$
	$a = -A\omega^2 \cos \omega t$
	$F = -m\omega^2 x$
	$E = \frac{1}{2} mA^2\omega^2$

energy stored in a capacitor	$W = \frac{1}{2} QV$
electric force	$F = \frac{Q_1 Q_2}{4\pi\epsilon_0 r^2}$
electrostatic potential energy	$W = \frac{Q_1 Q_2}{4\pi\epsilon_0 r}$
gravitational force	$F = \frac{-Gm_1 m_2}{r^2}$
gravitational potential energy	$E = \frac{-Gm_1 m_2}{r}$
magnetic force	$F = BIl \sin \theta$ $F = BQv \sin \theta$
electromagnetic induction	$E = \frac{-d(N\Phi)}{dt}$
Hall effect	$V = Bvd$
time dilation	$t' = \frac{t}{\sqrt{1 - \frac{v^2}{c^2}}}$
kinetic theory	$\frac{1}{2} m\langle c^2 \rangle = \frac{3}{2} kT$
work done on/by a gas	$W = p\Delta V$
radioactive decay	$\frac{dN}{dt} = -\lambda N$ $N = N_0 e^{-\lambda t}$ $t_{\frac{1}{2}} = \frac{\ln 2}{\lambda}$
attenuation losses	$I = I_0 e^{-\mu x}$
mass-energy equivalence	$\Delta E = c^2 \Delta m$
hydrogen energy levels	$E_n = \frac{-13.6 \text{ eV}}{n^2}$
Heisenberg uncertainty principle	$\Delta p \Delta x \geq \frac{h}{2\pi}$ $\Delta E \Delta t \geq \frac{h}{2\pi}$
Wien's law	$\lambda_{\text{max}} \propto \frac{1}{T}$
Stefan's law	$L = 4\pi\sigma r^2 T^4$
electromagnetic radiation from a moving source	$\frac{\Delta\lambda}{\lambda} \approx \frac{\Delta f}{f} \approx \frac{v}{c}$

1 Which one of the following groups contains three vector quantities?

- A displacement, velocity, energy
- B displacement, velocity, momentum
- C force, work, energy
- D velocity, acceleration, power

2 Uncertainties in measurement may be either systematic or random.

Which of the following involves random uncertainty?

- A not allowing for zero uncertainty on a voltmeter
- B not subtracting background count rate when determining the count rate from a radioactive source
- C stopping a stopwatch at the end of a race
- D using the value $g = 10 \text{ N kg}^{-1}$ when calculating weight from mass

3 A uniform loft door of weight W and length 0.8 m is in equilibrium. It is hinged at X and supported by a rope passing over a pulley. The tension in the supporting rope is T . Which of the following equations applies when moments are taken about X?

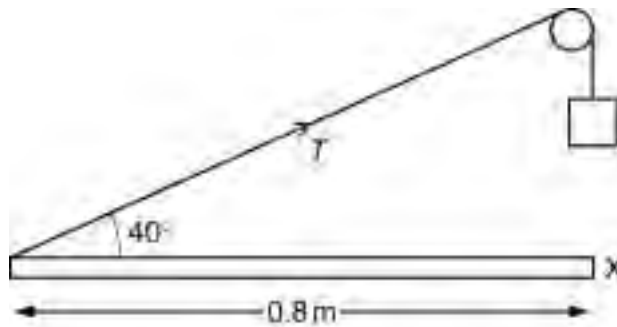

- A $T \sin 40^\circ = 0.4W$
- B $0.8T \cos 50^\circ = 0.4W$
- C $0.8T = 0.4W$
- D $2T \sin 50^\circ = W$

- 4 A person throws a ball vertically upwards. It rises to a maximum height, where it is momentarily at rest, and then falls back down.

Which of the following gives the acceleration of the ball at various stages in its motion? Take vertically upwards as positive. Neglect air resistance.

	rising	at maximum height	falling
A	-9.81 m s^{-2}	0	$+9.81 \text{ m s}^{-2}$
B	-9.81 m s^{-2}	-9.81 m s^{-2}	-9.81 m s^{-2}
C	$+9.81 \text{ m s}^{-2}$	$+9.81 \text{ m s}^{-2}$	$+9.81 \text{ m s}^{-2}$
D	$+9.81 \text{ m s}^{-2}$	0	-9.81 m s^{-2}

- 5 Two markers M_1 and M_2 are set up a vertical distance h apart.

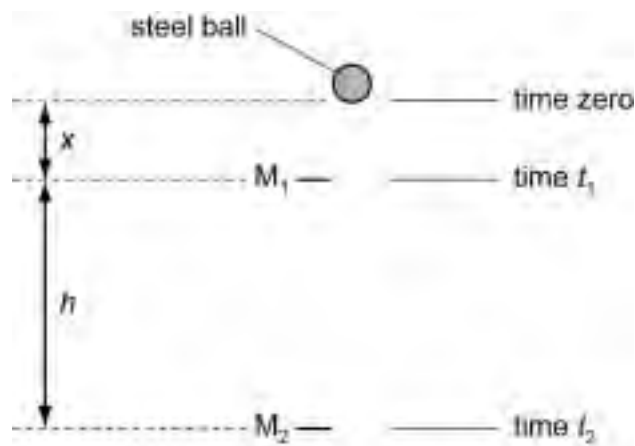

A steel ball is released at time zero from a point a distance x above M_1 . The ball reaches M_1 at time t_1 and reaches M_2 at time t_2 . The acceleration of the ball is constant.

Which expression gives the acceleration of the ball?

- A** $\frac{2h}{t_2^2}$ **B** $\frac{2h}{(t_2 + t_1)}$ **C** $\frac{2h}{(t_2 - t_1)^2}$ **D** $\frac{2h}{(t_2^2 - t_1^2)}$

- 6 A small part of the Earth's gravitational field close to the surface of the Earth is uniform.

Which of the following statements is **not** correct?

- A The field lines are parallel to each other.
- B The units of gravitational field strength are equivalent to m s^{-2} .
- C The gravitational force on an object is proportional to its height above the Earth's surface.
- D The direction of the field lines is towards the Earth.

- 7 A person is in contact with the Earth. Four forces act. They are

force *W* the weight of the person
 force *X* the pull of the person on the Earth due to gravity
 force *Y* the contact force of the person on the ground
 force *Z* the contact force of the ground on the person

Which pair of forces **must always** have the same magnitude, according to Newton's third law?

- A force *W* and force *X*
 - B force *W* and force *Y*
 - C force *X* and force *Y*
 - D force *W* and force *Z*
- 8 Liquids X and Y are stored in large open tanks. Liquids X and Y have densities of 800 kg m^{-3} and 1200 kg m^{-3} respectively.

At what depths are the pressures equal?

	depth in liquid X	depth in liquid Y
A	8 m	12 m
B	10 m	10 m
C	15 m	10 m
D	18 m	8 m

- 9 A wire stretches 8.0 mm under a load of 60 N.

A second wire of the same material, with half the diameter and a quarter of the original length of the first wire, is stretched by the same load.

Assuming that Hooke's law is obeyed, what is the extension of this wire?

- A 0.5 mm B 1.0 mm C 4.0 mm D 8.0 mm
- 10 A ductile material is stretched by a tensile force to a point beyond its elastic limit. The tensile force is then reduced to zero. The graph of force against extension is shown below.

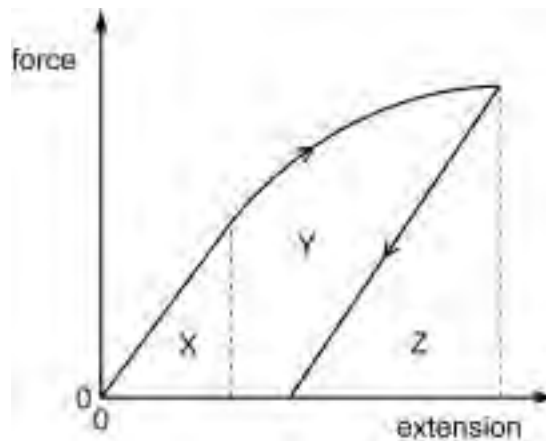

Which area represents the net work done on the sample?

- A X B X + Y C Y + Z D Z
- 11 An electric kettle has a power output of 1.6 kW. It is used to heat 1.7 kg of water from a temperature of 18 °C to 98 °C. The specific heat capacity of water is 4200 J kg⁻¹ K⁻¹.

What is the least time it could take to cause this temperature rise?

- A 52 s B 120 s C 360 s D 440 s
- 12 An aircraft moving through air at velocity v experiences a resistive force F given by the expression

$$F = kv^2,$$

where k is a constant.

What is the power required to keep the aircraft moving at this constant velocity?

- A kv B kv^2 C kv^3 D kv^4

- 13 The diagram shows a trolley being pulled from rest along a horizontal table by a falling mass. The trolley mass is 1.5 kg and the falling mass falls through 1.0 m.

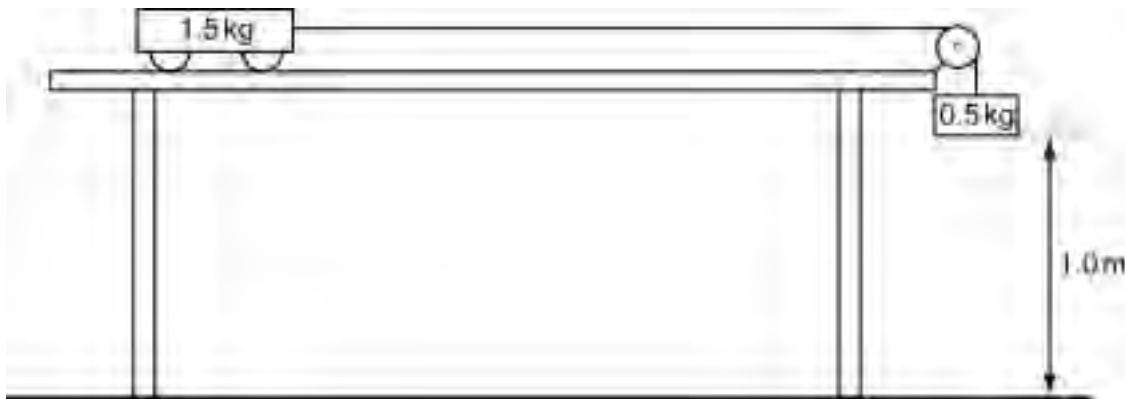

What is the maximum kinetic energy of the trolley?

- A 3.7 J B 4.9 J C 15 J D 20 J
- 14 The diagram shows two trolleys X and Y held stationary and connected by an extended elastic cord. The mass of X is twice that of Y.

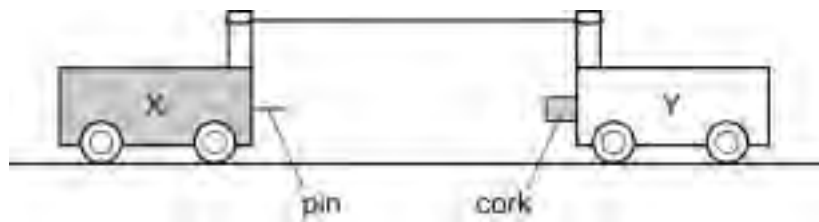

The trolleys are released at the same instant. They move towards each other and stick together on impact. Just before the collision, the speed of X is 20 cm s^{-1} .

What is the speed of Y just after the collision?

- A zero B 5 cm s^{-1} C 7 cm s^{-1} D 10 cm s^{-1}

- 15 A small electric motor is used to raise a mass of weight 2.0 N at a constant velocity through a vertical height of 80 cm in 4.0 s.

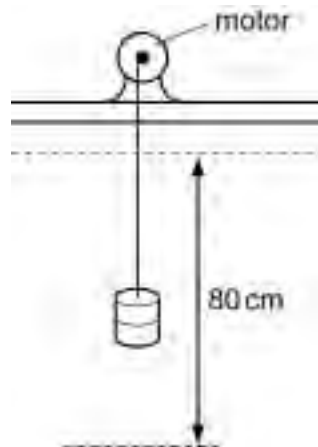

The efficiency of the motor is 20%.

What is the electrical power supplied to the motor?

- A** 0.080 W **B** 0.80 W **C** 2.0 W **D** 200 W
- 16 A battery, during its useable lifetime, supplies a constant current of $40 \mu\text{A}$ to a clock for 800 days.
- How much charge does the battery supply during this time?

- A** $20 \mu\text{C}$ **B** $32\,000 \mu\text{C}$ **C** 46 C **D** 2800 C

17 The diagram shows a circuit with four positive voltmeter readings V_1 , V_2 , V_3 and V .

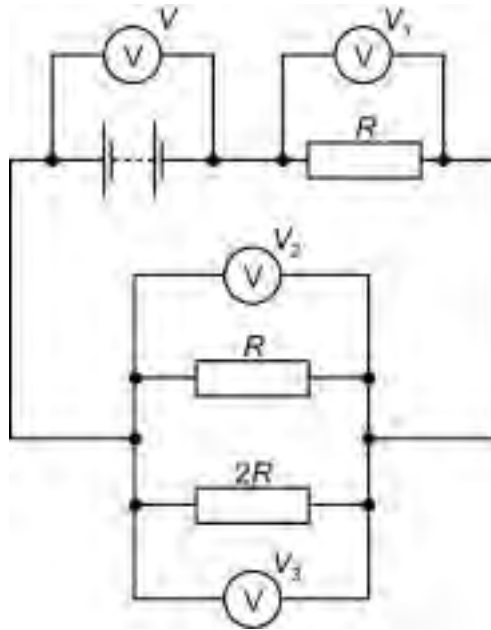

Which equation relating the voltmeter readings must be true?

- A $V = V_1 + V_2 + V_3$
- B $V + V_1 = V_2 + V_3$
- C $V_3 = 2V_2$
- D $V - V_1 = V_2$

18 The electrical characteristic of a component is shown below.

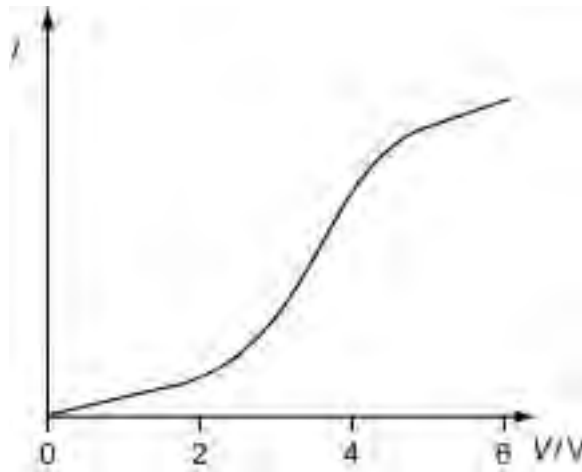

Which graph shows the way the resistance of the component varies with applied voltage?

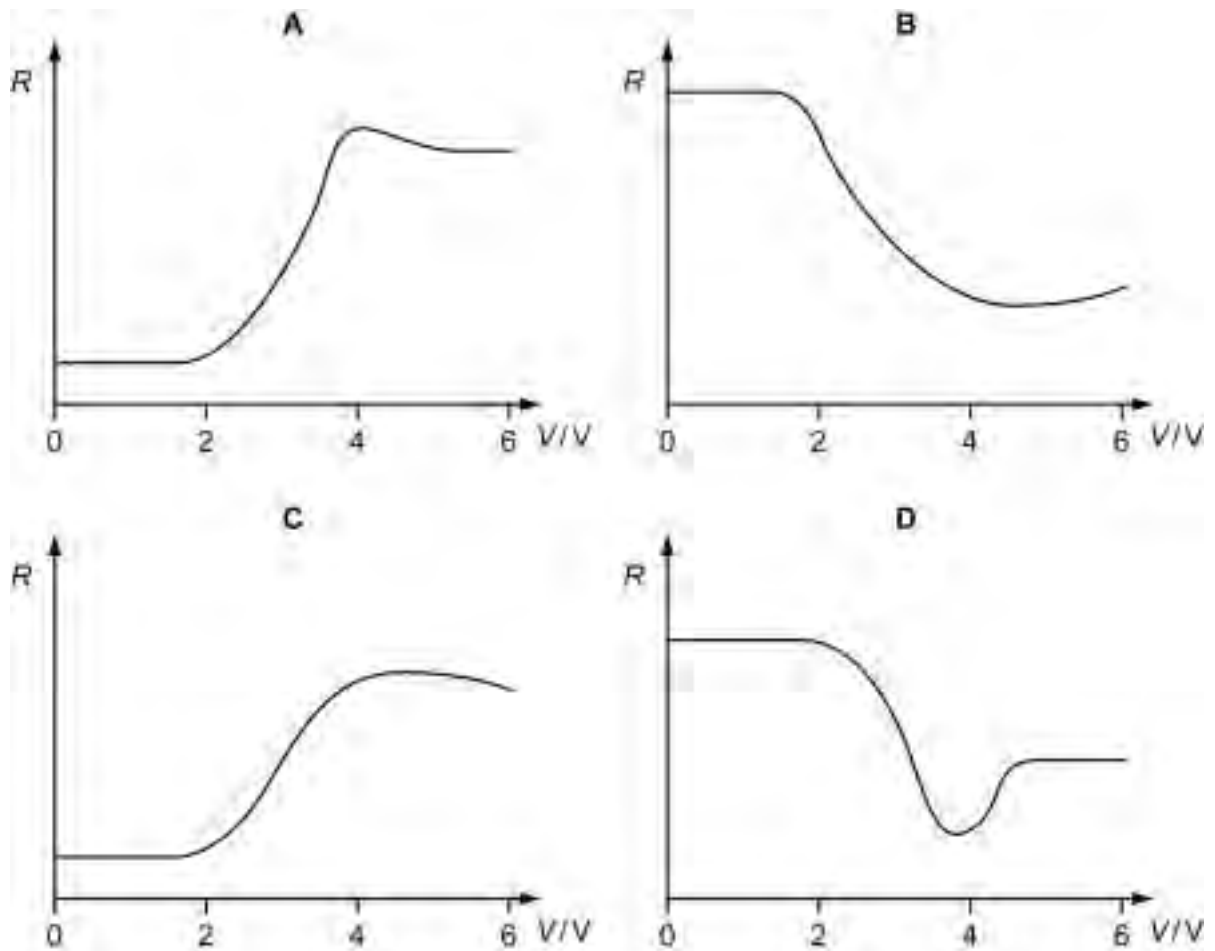

- 19 A composite wire is made by connecting in series four uniform wires made of the same material, but having different diameters.



The resistance R of this composite wire is measured between X and other points on the wire at distances d from X .

Which graph best represents the relationship between R and d ?

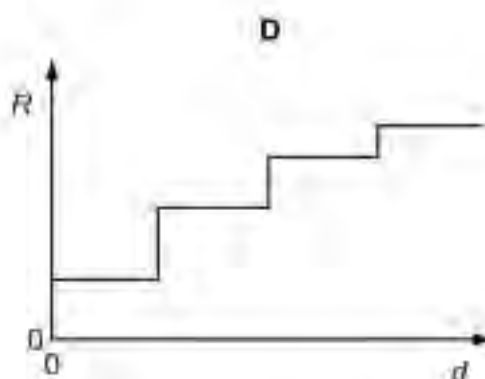
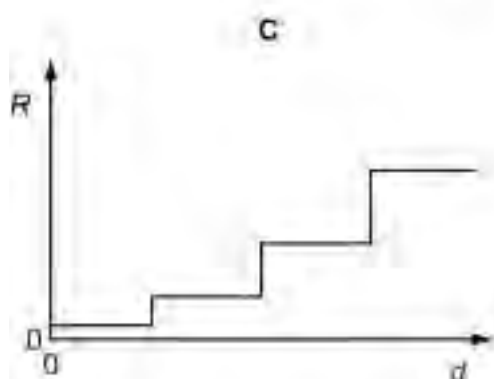
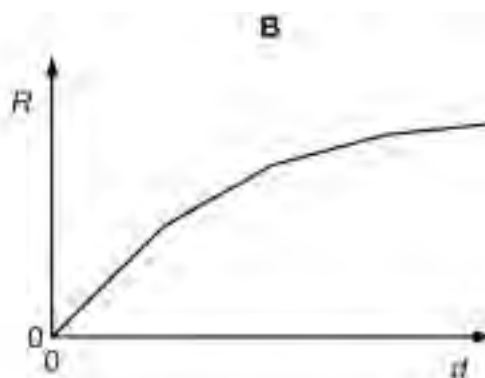
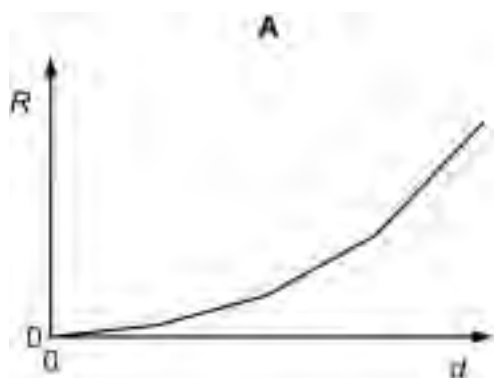

- 20 A battery of e.m.f. E and internal resistance r is connected to a 4.0Ω resistor. A p.d. of 5.2 V is measured across the terminals of the battery. When the 4.0Ω resistor is replaced with one of resistance 12.0Ω , the p.d. across the battery becomes 6.0 V .

What are the values of E and r ?

	E/V	r/Ω
A	6.5	1.0
B	7.5	1.8
C	7.6	0.63
D	12	6.0

21

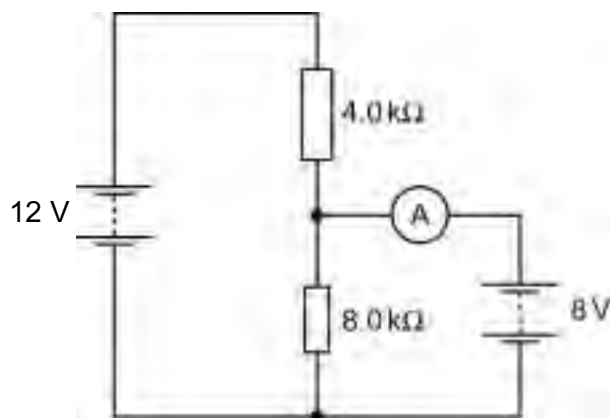

In the above circuit, what is the current in the ammeter? Assume that the ammeter and the batteries have negligible internal resistance.

- A 2.0 mA
- B 1.0 mA
- C 0.50 mA
- D zero

22 A transverse progressive wave travels along a rope. The graph shows the variation of displacement with distance along the rope at a certain time. The wave is travelling to the right.

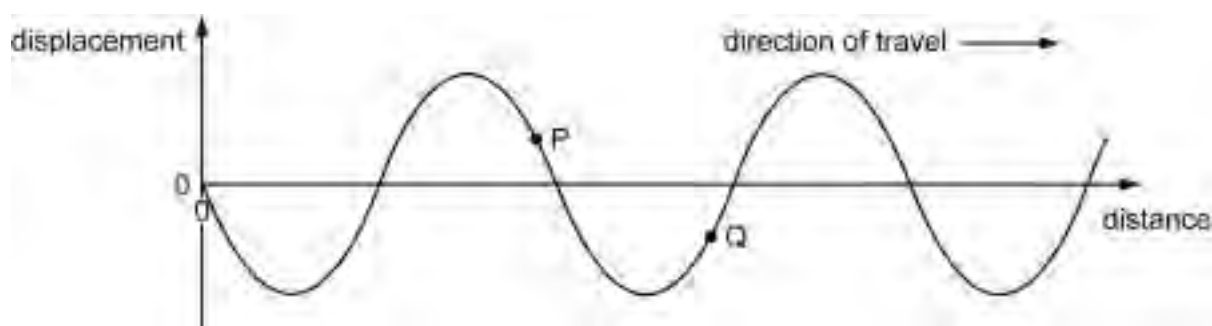

In which direction are the points P and Q on the rope moving?

	movement of P	movement of Q
A	downwards	downwards
B	downwards	upwards
C	upwards	downwards
D	upwards	upwards

- 23 A sound wave is emitted from a point source. The intensity of the sound wave is inversely proportional to the square of the distance from the source. At a distance r from the source the amplitude of the wave is $8X$.

What is the amplitude at a distance $2r$ from the source?

- A $8X$ B $4X$ C $2X$ D X
- 24 Polarisation is a phenomenon associated with a certain type of wave.
- Which condition must be satisfied if a wave is to be polarised?
- A It must be a light wave.
B It must be a longitudinal wave.
C It must be a radio wave.
D It must be a transverse wave.
- 25 A source of monochromatic light is viewed through a diffraction grating.

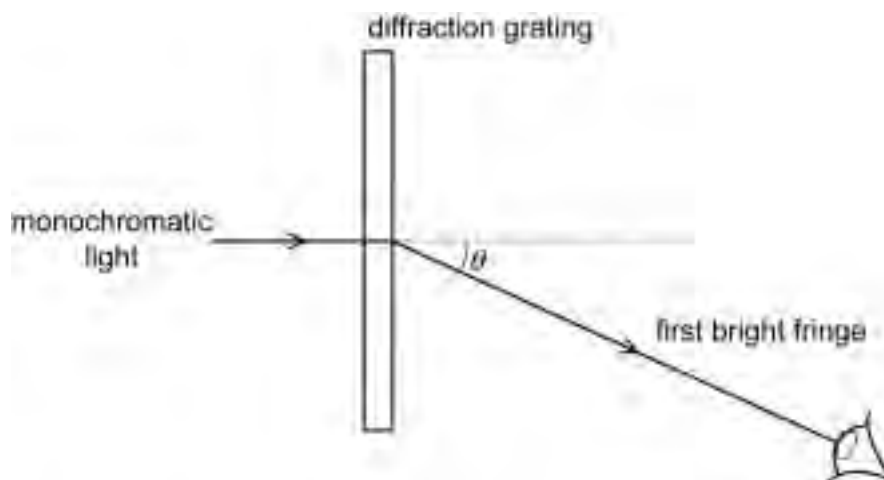

Which of the following causes the angle θ to increase?

- A decreasing the distance between adjacent slits on the grating
B decreasing the wavelength of the monochromatic light
C increasing the distance of the eye from the grating
D increasing the number of slits on the grating but keeping the slit spacing the same

- 26 In an optical fibre, light travelling along the core of the fibre with a speed of $1.874 \times 10^8 \text{ m s}^{-1}$ meets the boundary with the cladding. The speed of light in the cladding is $1.902 \times 10^8 \text{ m s}^{-1}$.

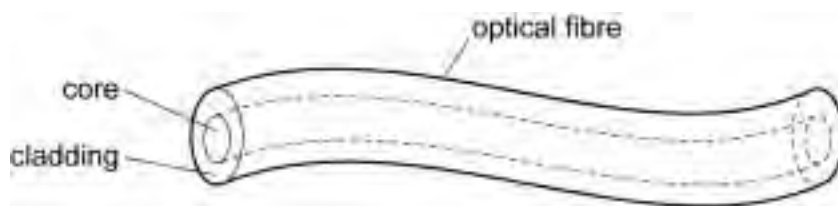

What is the minimum angle of incidence for the light in the core for it to undergo total internal reflection at the core-cladding interface?

- A $3.01 \times 10^{-7}^\circ$ B 9.8° C 41.8° D 80.2°
- 27 Which diagram best represents the paths of α -particles with equal energies scattered by a gold nucleus?

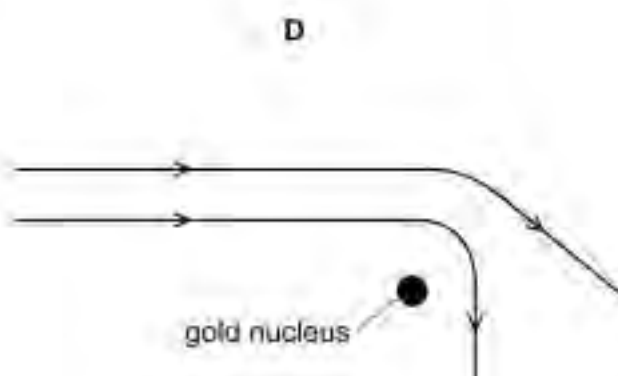
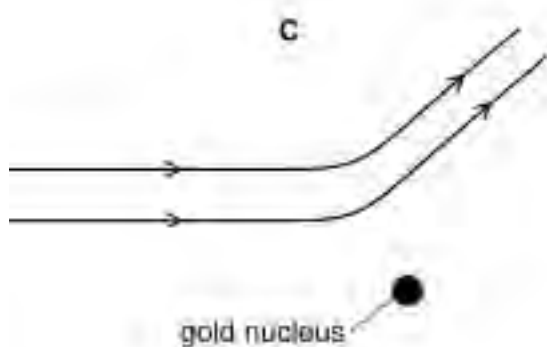
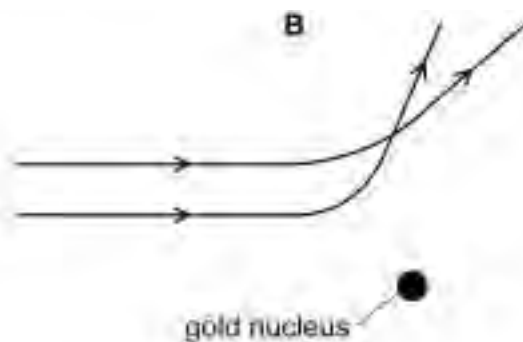
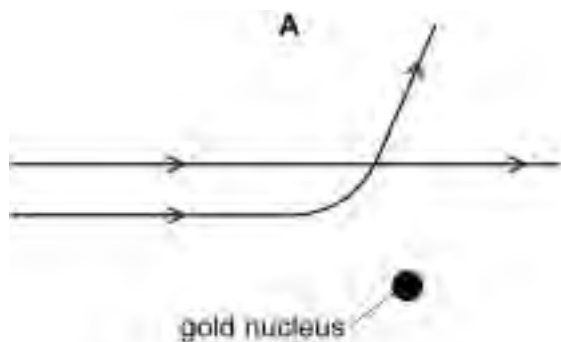

28 Which are the correct descriptions of α - and β^- and γ -radiations?

	α	β^-	γ
A	helium-4 nucleus	electromagnetic radiation	high speed electron
B	helium-4 nucleus	high speed electron	electromagnetic radiation
C	electromagnetic radiation	high speed electron	helium-4 nucleus
D	high speed electron	helium-4 nucleus	electromagnetic radiation

29 Uranium-235 has nucleon number 235, proton number 92 and neutron number 143. Data on four other nuclides are given below.

Which is an isotope of uranium?

	nucleon number	proton number	neutron number
A	235	91	144
B	236	92	144
C	237	94	143
D	238	95	143

30 A nickel nucleus ${}_{28}^{59}\text{Ni}$ can be transformed by a process termed K-capture. In this process the nucleus absorbs an orbital electron and converts a proton to a neutron.

When no other process is involved, what is the resulting nucleus?

- A** ${}_{28}^{58}\text{Ni}$ **B** ${}_{27}^{59}\text{Co}$ **C** ${}_{27}^{60}\text{Co}$ **D** ${}_{29}^{59}\text{Cu}$

31 The initial activity of a sample of a radioactive nuclide containing N_0 nuclei is 4.8×10^3 Bq.

How many nuclei will have already decayed by the time the activity is 6.0×10^2 Bq?

- A** $\frac{1}{8} N_0$ **B** $\frac{3}{4} N_0$ **C** $\frac{7}{8} N_0$ **D** $\frac{15}{16} N_0$

32 Which equation correctly shows an α -particle causing a nuclear reaction?

- A** ${}_{7}^{14}\text{N} + {}_{2}^{4}\text{He} \rightarrow {}_{8}^{17}\text{O} + {}_{1}^{1}\text{n}$
B ${}_{8}^{17}\text{O} + {}_{2}^{4}\text{He} \rightarrow {}_{9}^{20}\text{F} + {}_{1}^{1}\text{p}$
C ${}_{8}^{17}\text{O} + {}_{-1}^{0}\text{e} \rightarrow {}_{5}^{13}\text{B} + {}_{2}^{4}\text{He}$
D ${}_{7}^{14}\text{N} + {}_{1}^{1}\text{p} \rightarrow {}_{6}^{11}\text{C} + {}_{2}^{4}\text{He}$

- 33 Samples of two radioactive nuclides X and Y each have equal activity A_0 at time $t = 0$. X has a half-life of 24 years and Y has a half-life of 16 years. The samples are mixed together. What will be the total activity of the mixture at time $t = 48$ years?

A $\frac{1}{12} A_0$ B $\frac{3}{16} A_0$ C $\frac{1}{4} A_0$ D $\frac{3}{8} A_0$

- 34 Which graph shows how the energy E of a photon of light is related to its wavelength λ ?

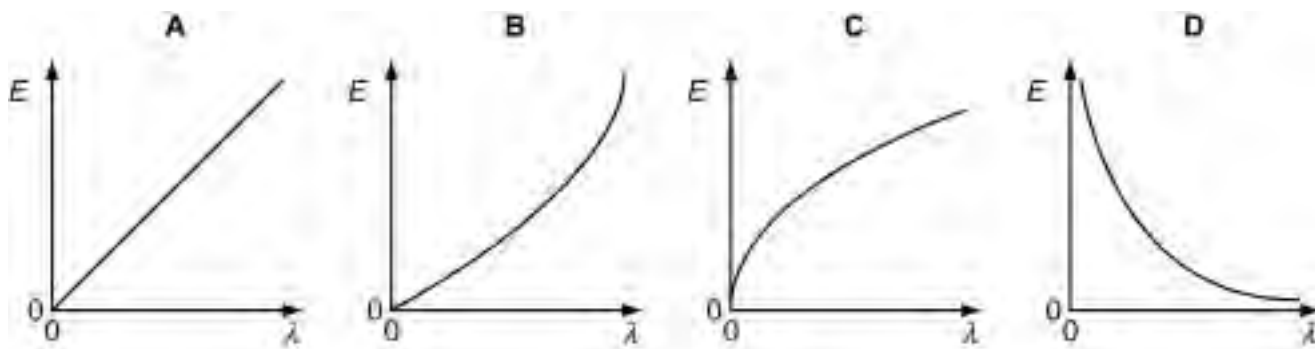

- 35 In the photoelectric effect, light incident on a metal surface causes electrons to be ejected from the surface.

Which statement is correct?

- A Electrons are ejected only if the wavelength of the incident light is greater than some minimum value.
- B The de Broglie wavelength of the ejected electrons is the same as the wavelength of the incident light.
- C The maximum energy of the electrons is independent of the intensity of the incident light.
- D The maximum energy of the electrons is independent of the type of metal.
- 36 Atoms in a gas emit photons of light of energy 2.44 eV.

What is the wavelength of the emitted radiation?

	wavelength / m
A	3.90×10^{-7}
B	5.09×10^{-7}
C	3.90×10^{-9}
D	5.09×10^{-9}

37 What are the meanings of the prefixes pico (p) and giga (G)?

	pico (p)	giga (G)
A	$\times 10^{-9}$	$\times 10^9$
B	$\times 10^{-9}$	$\times 10^{12}$
C	$\times 10^{-12}$	$\times 10^9$
D	$\times 10^{-12}$	$\times 10^{12}$

38 A metal sphere of radius r is dropped into a tank of water. As it sinks at speed v , it experiences a drag force F given by

$$F = krv,$$

where k is a constant.

What are the SI base units of k ?

- A** $\text{kg m}^2 \text{s}^{-1}$ **B** $\text{kg m}^{-2} \text{s}^{-2}$ **C** $\text{kg m}^{-1} \text{s}^{-1}$ **D** kg m s^{-2}

39 An early experimenter, working in units other than SI units, measured the charge on tiny oil drops. Each oil drop was charged by just a few electrons. The charges he obtained were

9.82 19.64 39.28 39.28 34.37 19.64 19.64

What value do these results suggest for the charge on the electron as measured in these units?

- A** 2.45 **B** 4.91 **C** 9.82 **D** 19.64

40 An Olympic athlete competes in a sprint race.

What is the best estimate of his mean kinetic energy during the race?

- A** $4 \times 10^2 \text{ J}$ **B** $4 \times 10^3 \text{ J}$ **C** $4 \times 10^4 \text{ J}$ **D** $4 \times 10^5 \text{ J}$

Permission to reproduce items where third-party owned material protected by copyright is included has been sought and cleared where possible. Every reasonable effort has been made by the publisher (UCLES) to trace copyright holders, but if any items requiring clearance have unwittingly been included, the publisher will be pleased to make amends at the earliest possible opportunity.

University of Cambridge International Examinations is part of the Cambridge Assessment Group. Cambridge Assessment is the brand name of University of Cambridge Local Examinations Syndicate (UCLES), which is itself a department of the University of Cambridge.



UNIVERSITY OF CAMBRIDGE INTERNATIONAL EXAMINATIONS
Cambridge International Level 3 Pre-U Certificate
Principal Subject

PHYSICS

9792/01

Paper 1 Part A Multiple Choice

SPECIMEN MARK SCHEME

1 hour 15 minutes

MAXIMUM MARK: 40

This document consists of **2** printed pages.



UNIVERSITY *of* CAMBRIDGE
International Examinations

[Turn over

<i>Question Number</i>	<i>Key</i>	<i>Question Number</i>	<i>Key</i>
1	B	21	D
2	C	22	C
3	B	23	B
4	B	24	D
5	D	25	A
6	C	26	D
7	A	27	B
8	C	28	B
9	D	29	B
10	B	30	B
11	C	31	C
12	C	32	B
13	A	33	D
14	A	34	D
15	C	35	C
16	D	36	B
17	D	37	C
18	B	38	C
19	A	39	B
20	A	40	B



UNIVERSITY OF CAMBRIDGE INTERNATIONAL EXAMINATIONS
Cambridge International Level 3 Pre-U Certificate
Principal Subject

CANDIDATE
NAME

--

CENTRE
NUMBER

--	--	--	--	--

CANDIDATE
NUMBER

--	--	--	--

PHYSICS

9792/02

Paper 2 Part A Written Paper

SPECIMEN PAPER

2 hours

Candidates answer on the Question Paper.

No Additional Materials are required.

READ THESE INSTRUCTIONS FIRST

Write your Centre number, candidate number and name on all the work you hand in.

Write in dark blue or black pen in the spaces provided.

You may use a soft pencil for any diagrams, graphs or rough working.

Do not use stapes, paper clips, highlighters, glue or correction fluid.

Section A

Answer **all** questions. You are advised to spend 1½ hours on this section.

Section B

Answer the **one** question. You are advised to spend 30 minutes on this section.
The question is based on the material in the Insert.

You are advised to show all working in calculations.

At the end of the examination, fasten all your work securely together.

The number of marks is given in brackets [] at the end of each question or part question.

For Examiner's Use	
1	
2	
3	
4	
5	
6	
7	
8	
Total	

This document consists of **19** printed pages, **1** blank page and **1** insert.



Data

gravitational field strength close to Earth's surface	$g = 9.81 \text{ N kg}^{-1}$
elementary charge	$e = 1.60 \times 10^{-19} \text{ C}$
speed of light in vacuum	$c = 3.00 \times 10^8 \text{ m s}^{-1}$
Planck constant	$h = 6.63 \times 10^{-34} \text{ J s}$
permittivity of free space	$\epsilon_0 = 8.85 \times 10^{-12} \text{ F m}^{-1}$
gravitational constant	$G = 6.67 \times 10^{-11} \text{ N m}^2 \text{ kg}^{-2}$
electron mass	$m_e = 9.11 \times 10^{-31} \text{ kg}$
proton mass	$m_p = 1.67 \times 10^{-27} \text{ kg}$
unified atomic mass constant	$u = 1.66 \times 10^{-27} \text{ kg}$
molar gas constant	$R = 8.31 \text{ J K}^{-1} \text{ mol}^{-1}$
Avogadro constant	$N_A = 6.02 \times 10^{23} \text{ mol}^{-1}$
Boltzmann constant	$k = 1.38 \times 10^{-23} \text{ J K}^{-1}$
Stefan-Boltzmann constant	$\sigma = 5.67 \times 10^{-8} \text{ W m}^{-2} \text{ K}^{-4}$

Formulae

uniformly accelerated motion	$s = ut + \frac{1}{2} at^2$ $v^2 = u^2 + 2as$ $s = \left(\frac{u+v}{2} \right) t$
heating	$\Delta E = mc\Delta\theta$
change of state	$\Delta E = mL$
refraction	$n = \frac{\sin \theta_1}{\sin \theta_2}$ $n = \frac{v_1}{v_2}$
photon energy	$E = hf$
de Broglie wavelength	$\lambda = \frac{h}{p}$
simple harmonic motion	$x = A \cos \omega t$ $v = -A\omega \sin \omega t$ $a = -A\omega^2 \cos \omega t$ $F = -m\omega^2 x$ $E = \frac{1}{2} mA^2\omega^2$

energy stored in a capacitor	$W = \frac{1}{2} QV$
electric force	$F = \frac{Q_1 Q_2}{4\pi\epsilon_0 r^2}$
electrostatic potential energy	$W = \frac{Q_1 Q_2}{4\pi\epsilon_0 r}$
gravitational force	$F = \frac{-Gm_1 m_2}{r^2}$
gravitational potential energy	$E = \frac{-Gm_1 m_2}{r}$
magnetic force	$F = BIl \sin \theta$ $F = BQv \sin \theta$
electromagnetic induction	$E = \frac{-d(N\Phi)}{dt}$
Hall effect	$V = Bvd$
time dilation	$t' = \frac{t}{\sqrt{1 - \frac{v^2}{c^2}}}$
kinetic theory	$\frac{1}{2} m\langle c^2 \rangle = \frac{3}{2} kT$
work done on/by a gas	$W = p\Delta V$
radioactive decay	$\frac{dN}{dt} = -\lambda N$ $N = N_0 e^{-\lambda t}$ $t_{\frac{1}{2}} = \frac{\ln 2}{\lambda}$
attenuation losses	$I = I_0 e^{-\mu x}$
mass-energy equivalence	$\Delta E = c^2 \Delta m$
hydrogen energy levels	$E_n = \frac{-13.6 \text{ eV}}{n^2}$
Heisenberg uncertainty principle	$\Delta p \Delta x \geq \frac{h}{2\pi}$ $\Delta E \Delta t \geq \frac{h}{2\pi}$
Wien's law	$\lambda_{\text{max}} \propto \frac{1}{T}$
Stefan's law	$L = 4\pi\sigma r^2 T^4$
electromagnetic radiation from a moving source	$\frac{\Delta\lambda}{\lambda} \approx \frac{\Delta f}{f} \approx \frac{v}{c}$

Section A

Answer **all** of the questions in this section.
You are advised to spend 1½ hours answering this section.

For
Examiner's
Use

- 1 A car is stopped by varying the braking force. The braking force is increased to a maximum and then reduced, at the same rate, to zero just as stopping occurs. In this way a passenger in the car is subjected to the least possible jerk. The acceleration of the car, during the 10 s braking time, is shown in Fig. 1.1.

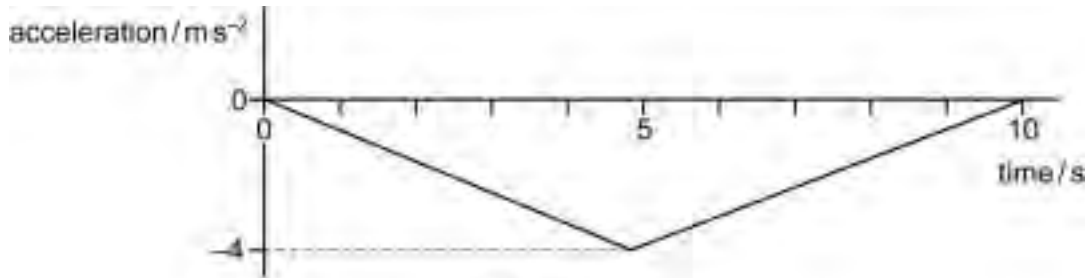

Fig. 1.1

- (a) State what is meant by the term *acceleration*.

.....
..... [1]

- (b) On the axes of Fig. 1.2, sketch a graph to show how the velocity of the car will change during the 10 seconds braking time. The car starts with a velocity of 20 m s^{-1} .

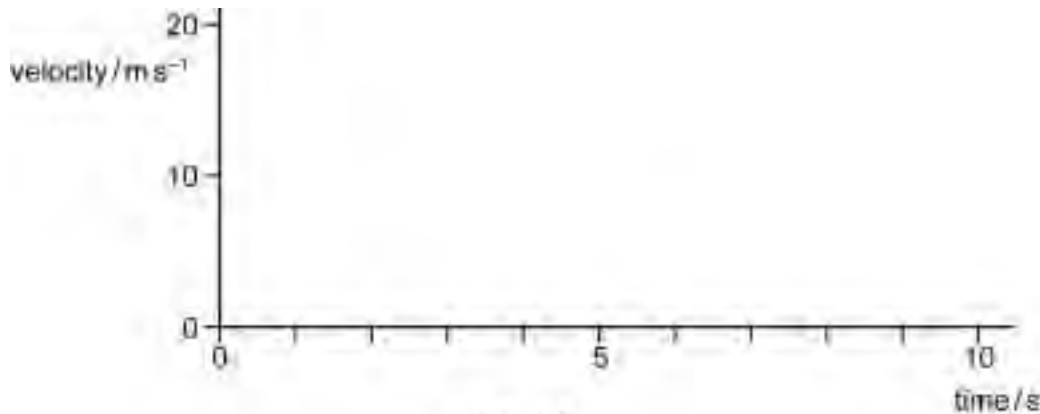

Fig. 1.2

[3]

- (c) (i) What feature of a velocity-time graph gives the displacement?

.....
..... [1]

(ii) Estimate the total distance travelled while braking. Show your reasoning.

stopping distance = [2]

(iii) On the axes of Fig. 1.3, sketch a displacement-time graph for the car for the 10 seconds braking time.

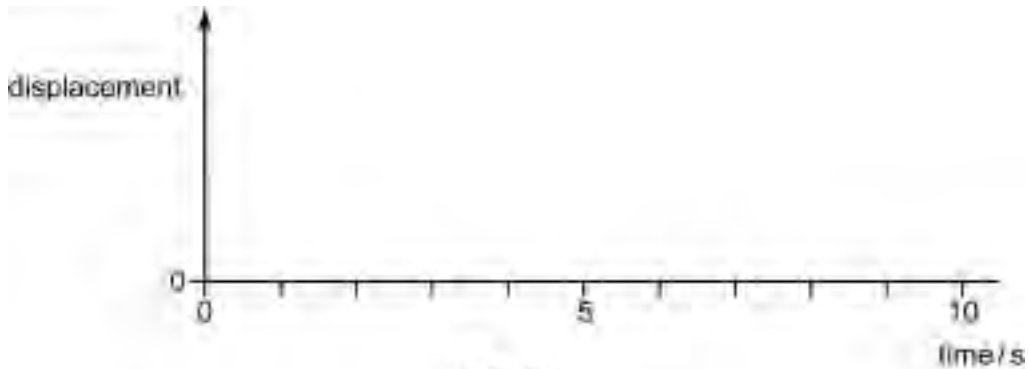

Fig. 1.3

[2]

(d) Suggest why this method of stopping is more comfortable for the passenger than a more usual method where the braking force is kept constant during deceleration.

.....
.....
.....
.....
.....
.....
.....
..... [2]

[Total: 11]

- 2 (a) A rechargeable battery is put on charge for 4.0 hours with a constant current of 50 mA from a 6.0 V supply. Calculate the energy that has been provided from the supply.

energy = [3]

- (b) In what form does a battery store energy?

..... [1]

- (c) The charged battery has an e.m.f. of 4.5 V and is connected to a 48 Ω resistor. The potential difference across the resistor is found to be 4.0 V. The current is constant during the 45 minutes the battery discharges. Calculate

- (i) the internal resistance of the battery when in use,

internal resistance = [3]

- (ii) the energy supplied to the 48 Ω resistor in this time,

energy = [2]

- (iii) the percentage of the energy supplied to the battery during charge which is provided to the $48\ \Omega$ resistor on discharge.

*For
Examiner's
Use*

percentage = [1]

- (d) Explain why the value of the internal resistance calculated in (c) (i) is only reliable to one significant figure.

.....
..... [1]

[Total: 11]

- 3 A person of weight 600 N does a bungee jump using an elastic rope of unstretched length 50 m and having a spring constant k equal to 67 N m^{-1} . During the initial fall there is a transfer of energy from gravitational potential energy to kinetic energy and elastic potential energy, as shown in the table. The person falls through a distance of 90 m before beginning to move upwards.

Assuming that frictional losses are negligible, complete the table.

distance of fall/ m	gravitational potential energy /J	elastic potential energy /J	kinetic energy /J
0	54 000	0	0
20	42 000	0	
40	30 000	0	24 000
50	24 000		
60			
90	0		

[Total: 8]

- 4 Fig. 4.1 is a diagram of an electromagnetic wave travelling in a vacuum. The distance axis is drawn to full scale.

For
Examiner's
Use

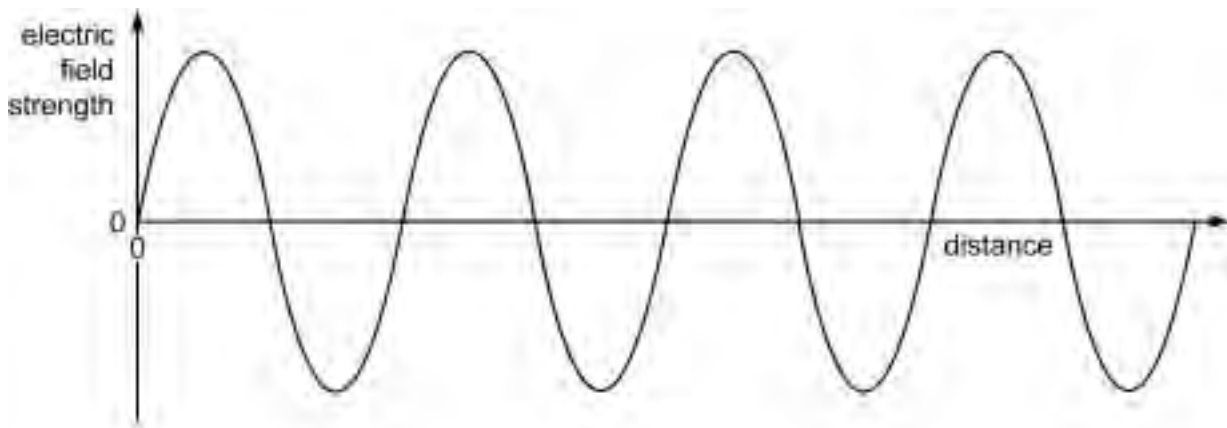

Fig. 4.1

- (a) State the speed of the wave in Fig. 4.1.

speed = [1]

- (b) (i) Accurately measure the wavelength of the electromagnetic wave in Fig. 4.1. Show your working and give your answer to a suitable number of significant figures.

wavelength = [3]

- (ii) Calculate the frequency of the wave.

frequency = [2]

- (c) Waves of this type are used in radar systems where they are passed along tubes called waveguides. One part of the system can be a double tube as shown in Fig. 4.2.

For
Examiner's
Use

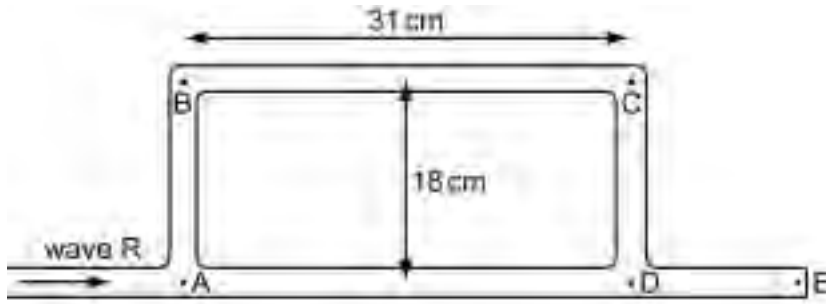

Fig. 4.2

The lengths of the wave paths in the tube are 18 cm and 31 cm as shown. The wavelength of the radar waves in the waveguide is 4.0 cm.

- (i) A wave R can divide at A and reach C either by path ABC or by path ADC. What is the length of each of these paths?

path length ABC =

path length ADC =

[1]

- (ii) State the phase difference between the two waves arriving at C and comment on the amplitude of the resultant wave.

.....

[2]

(iii) Another wave T travelling from E in the opposite direction is shown in Fig. 4.3.

For
Examiner's
Use

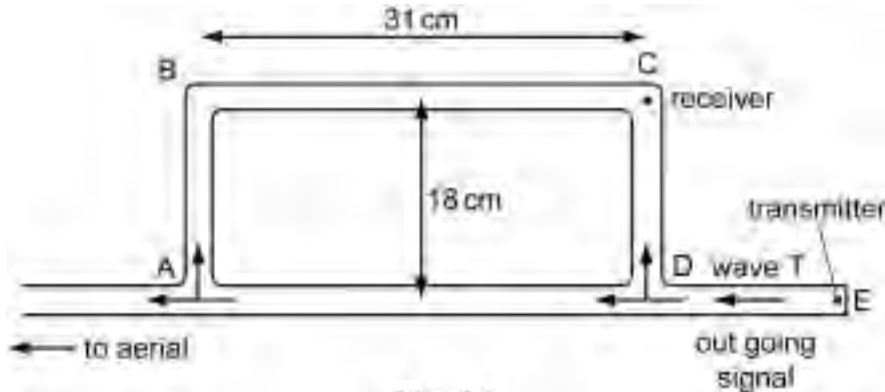

Fig. 4.3

The wave reaches C by paths DABC or DC. Waves of equal intensity travel along each path.

1. What is the path length of each of these paths?

path length DC =

path length DABC =

[1]

2. Determine the phase difference between the two waves arriving at C and comment on the amplitude of the resultant wave.

.....

 [2]

(iv) In a radar system, a powerful transmitter is placed at E while a receiver of weak incoming signals is placed at C. Suggest why this arrangement of waveguides is necessary.

.....

 [3]

[Total: 15]

- 5 A photocell is illuminated with ultra-violet light of wavelength 328 nm and photoelectrons are emitted. The potential difference across the photocell is varied and the current is monitored. A graph of current I against potential difference V is shown in Fig. 5.1.

For
Examiner's
Use

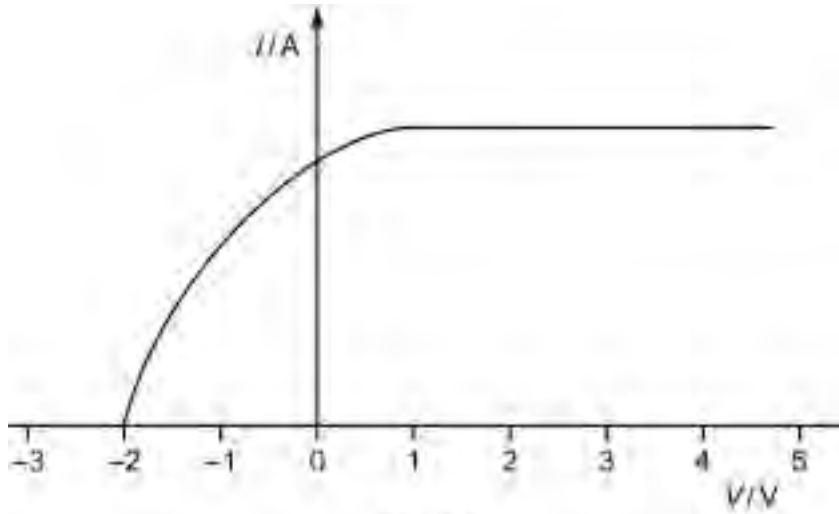

Fig. 5.1

- (a) Explain why the current has a maximum value.

.....

 [2]

- (b) Determine, in electron volts,

- (i) the maximum energy with which photoelectrons are emitted,

maximum electron energy = eV [1]

- (ii) the energy of photons from the ultra-violet lamp,

photon energy = eV [2]

(iii) the work function of the metal in the photocell.

*For
Examiner's
Use*

work function = eV [2]

(c) On Fig. 5.1, sketch an additional graph to show the effect of using the same ultra-violet light but at a lower intensity. [1]

[Total: 8]

- 6 Flow occurs in many different areas of Physics. For example, flow of electrons is an electric current, heat flow takes place as a result of a temperature gradient, and water or gas flow along pipes.

The dimensions of the material through which flow occurs, together with the properties of the material and the cause of flow, determine the amount of flow that takes place.

- (a) Explain why one pipe is necessary for the supply of gas to a house but two cables are necessary for the supply of electricity.

.....

.....

.....

..... [2]

- (b) The rate of flow of heat energy through the wall of a room is given by

$$\frac{Q}{t} = kA \left(\frac{\theta_2 - \theta_1}{d} \right)$$

where Q is the quantity of heat energy which flows in time t ,
 k is a constant called the thermal conductivity,
 A is the surface area of the wall,
 d is the thickness of the wall,
 θ_2 and θ_1 are the inside and outside temperatures respectively.

- (i) Deduce the SI unit of k .

unit of k = [3]

- (ii) The temperature inside a room is 22.0 °C and the outside temperature is 8.0 °C. The value of k for the wall of the room is 0.35 in SI units. Calculate the rate of flow of heat energy through the wall of thickness 0.10 m and area 12.0 m².

rate of flow of heat energy = [2]

- (c) (i) Write an equation, analogous to that in (b), for the rate of flow of charge $\frac{Q}{t}$ through a wire. Your equation should be in terms of the potential difference V across the wire, the resistivity ρ of the material of which the wire is made and the length l and area of cross-section A of the wire.

[2]

- (ii) By comparing the equations in (c) (i) and (b),

1. state which thermal property corresponds with V ,

..... [1]

2. state which thermal property corresponds with ρ .

..... [1]

- (d) (i) The rate of flow of gas $\frac{V}{t}$ through a pipe may be measured in $\text{cm}^3 \text{s}^{-1}$. By analogy, suggest an equation for the rate of flow of gas. State the meaning of any symbols you introduce.

[3]

- (ii) $160 \text{ cm}^3 \text{ s}^{-1}$ of gas flows through a pipe of internal diameter 15 mm. Calculate the rate of flow of gas through a pipe of internal diameter 22 mm under the same conditions.

rate of flow of gas = [2]

[Total: 16]

7 Plutonium-239 decays by alpha-particle emission with a half-life of 2.4×10^4 years. The alpha-particle energy is 8.2×10^{-13} J.

(a) For a ${}^{239}_{94}\text{Pu}$ nucleus, state the number of protons and neutrons.

number of protons =

number of neutrons =

[1]

(b) A small power source to generate 2.5 W is to be made from a sample of Plutonium-239.

Calculate the activity of the sample of Plutonium-239, stating any assumptions that you make.

activity = [3]

(c) Another isotope of plutonium, Plutonium-238, also decays by alpha-emission but with a half-life of 86 years. The alpha-particle energy is 8.8×10^{-13} J.

State one advantage and one disadvantage of using Plutonium-238 instead of Plutonium-239 in the power source.

advantage

.....

.....

disadvantage

.....

..... [2]

[Total: 6]

Section B

*For
Examiner's
Use*

Answer the **one** question, referring to the Insert.
You are advised to spend 30 minutes answering this section.

8 According to the Greenpeace article 'Nuclear Power is the Wrong Answer', the nuclear industry sees 'nuclear power as the answer to carbon reduction targets and energy supply security'.

(a) Explain why carbon emissions are thought to be harmful to the environment.

.....
.....
.....
.....
.....
..... [3]

(b) Explain how building more nuclear power stations could help to reduce carbon emissions.

.....
.....
..... [2]

(c) Suggest why the government is concerned about 'energy supply security'.

.....
..... [1]

(d) The Greenpeace article includes the following statement.

'Existing British nuclear power stations will leave a legacy of half a million tonnes of nuclear waste that the government has no idea how to dispose of safely. This waste will remain a threat to our health and the environment for a million years.'

For
Examiner's
Use

Do you think this is a fair statement? Your answer should explain

- why nuclear waste is hazardous,
- how the waste is being dealt with at the moment,
- why nuclear waste is likely to remain a problem for a long period of time,
- whether you think the Greenpeace comment is fair.

.....
.....
.....
.....
.....
.....
.....
.....
.....
.....
.....
.....
.....
.....
.....
.....
.....
.....
.....
.....
.....

[10]

- (e) Explain why the production of plutonium is used as an argument against building more nuclear power stations.

*For
Examiner's
Use*

.....
.....
.....
.....
.....
.....
.....
.....
.....
.....
.....
.....
.....
.....
.....
.....
.....
.....
.....
.....
.....
.....
.....
.....
.....
.....

[9]

[Total: 25]

BLANK PAGE

Permission to reproduce items where third-party owned material protected by copyright is included has been sought and cleared where possible. Every reasonable effort has been made by the publisher (UCLES) to trace copyright holders, but if any items requiring clearance have unwittingly been included, the publisher will be pleased to make amends at the earliest possible opportunity.

University of Cambridge International Examinations is part of the Cambridge Assessment Group. Cambridge Assessment is the brand name of University of Cambridge Local Examinations Syndicate (UCLES), which is itself a department of the University of Cambridge.



UNIVERSITY OF CAMBRIDGE INTERNATIONAL EXAMINATIONS
Cambridge International Level 3 Pre-U Certificate
Principal Subject

PHYSICS

9792/02

Paper 2 Part A Written Paper

SPECIMEN INSERT

2 hours

The extracts reproduced here are copies of the pre-release material, and should already be familiar to candidates.

This document consists of **8** printed pages.



EXTRACT 1: Nuclear Power is the Wrong Answer! (Greenpeace)

The UK government is currently reviewing the future direction of the UK's energy policy. The review is being used by Blair to give the go-ahead for a whole new generation of nuclear power stations.

The nuclear industry has recently launched a carefully orchestrated PR campaign to position nuclear power as the answer to carbon reduction targets and energy supply security. But nuclear power is the wrong answer:

It's dirty

Existing British nuclear power stations will leave a legacy of half a million tonnes of nuclear waste that the government has no idea how to dispose of safely. This waste will remain a threat to our health and the environment for a million years. Allowing the nuclear industry to build ten more nuclear power stations would add threefold to the amount of highly radioactive nuclear waste and spent fuel we have to deal with.

It's expensive

The decommissioning and clean up costs for the UK's existing nuclear industry have been estimated at £56bn – £70bn, with a further £20bn – £30bn needed for long-term management of the waste we currently have. That's equivalent to more than £1600 for every person in the UK.

It's not a solution to global warming

Even with the most optimistic build rate, a programme of 10 new nuclear reactors would only deliver a 4% cut in CO₂ emissions by 2024: too little, too late.

It's wasteful

Centralised power stations like nuclear reactors waste over $\frac{2}{3}$ of the energy in their fuel by throwing it away as heat. More is wasted in sending the electricity down the power lines. Only 22% of the original energy ends up actually being used in the home.

It undermines a clean energy future

Investment in nuclear power has consistently blocked funding going into renewable energy and energy efficiency. Every pound spent on nuclear is a pound less for effective solutions.

It's polluting

Every day, nuclear power stations pump radioactive pollution into the sea and air. These emissions can travel hundreds of kilometres, exposing wildlife and people to deadly radiation. The Irish Sea is now the most radioactively contaminated sea in the world because of discharges from Sellafield.

It's bad for your health

One particle of plutonium can cause fatal lung-cancer. The UK civil nuclear industry has a stockpile of 102 tonnes of plutonium with no plans for what to do with it.

It's dangerous

Every week trains carrying highly radioactive nuclear waste travel on Britain's outdated public rail network, through major cities and towns like London, Edinburgh and Bristol, often during peak hours. A serious accident or terrorist attack involving just one nuclear waste flask could force the evacuation of a large part of a city like London.

It's unpopular

A recent MORI poll found that only 8% of people would prefer nuclear to renewable sources of energy if the costs were the same.

It's fuel for the arms race

The British nuclear industry has created the third largest stockpile of plutonium in the world.

It's a potential terrorist target

Nuclear power stations are vulnerable to terrorist attack. Maps of Britain's most nuclear sites were reportedly found in the boot of a car linked to the July 2005 London bombers. A terrorist strike on the storage tanks holding dangerous liquid high-level radioactive waste at Sellafield has the potential to kill over two million people.

Good energy

But there is an alternative. The real solution to climate change is a wholesale reform of the centralised UK energy system to encourage massive efficiency and renewable energy sources on a huge scale: decentralised energy.

A recent report comparing nuclear and decentralised energy scenarios found that the nuclear scenario is dirtier, more dangerous, less secure and over £1bn more expensive than a decentralised scenario.

Source: *Greenpeace website – nuclear campaign*

EXTRACT 2: NIREX – Nuclear Waste Management

Everyone agrees that radioactive waste must be kept safely isolated from people and the environment, not just for our lifetimes, but for thousands of generations to come. In the UK most low-level waste is treated and disposed of as it is created. But we still need to agree on what to do with our growing stocks of intermediate and high-level waste. As a nation, we have tried and failed to reach consensus on this issue in the past. Now, as we enter a new millennium, we are trying once again.

Options frequently raised include:

- permanent surface storage;
- disposal in a specially designed repository deep underground;
- underground storage phase before eventual underground disposal.

The House of Lords has considered other options and found difficulties with most of them. Disposal of solid waste at sea is illegal by international convention. Exporting radioactive waste to other countries could be considered unacceptable on ethical grounds. Sending it into space is considered too dangerous. Processing the waste to reduce or remove its radioactivity presents formidable scientific and environmental challenges that restrict its applicability.

Types of solid radioactive waste and how they are treated and stored at the present time:

Description: **HIGH LEVEL WASTE:** Highly radioactive, heat generating.

Source: Reprocessing of spent nuclear fuel.

State: **Unconditioned:** in liquid form, stored in cooled tanks at Sellafield, Cumbria, and Dounreay, Caithness.

Conditioned: (13% of amount shown below in 1998) converted into glass and stored in stainless steel containers in air-cooled chambers at Sellafield.

Amount: About 1,800 m³ currently being stored.

Long-term disposal: There is as yet no policy for disposal.

Description: **INTERMEDIATE LEVEL WASTE:** Intermediate radioactivity.

Source: Waste and decommissioned facilities from nuclear power production, medicine, research and the military.

State: **Unconditioned:** metals, other solids and sludges stored where it arises.

Conditioned: (12% of amount shown below in 1998) immobilised in cement inside stainless steel drums and stored in purpose-built buildings.

Amount: About 70,000 m³ currently being stored.

Long-term disposal: There is a policy for disposal which is currently under review.

Description: **LOW LEVEL WASTE:** Slightly radioactive.

Source: Operation and decommissioning of nuclear facilities.

State: **Unconditioned:** equipment, paper, protective clothing from nuclear industry.

Conditioned: placed into containers and crushed into "pucks" which are cemented into metal containers.

Amount: Most (1 million m³) low-level waste to date is at BNFL's site at Drigg in Cumbria. Some is at Dounreay, Caithness.

Long-term disposal: Most is conditioned and disposed of as it is created.

Source: *Radioactive wastes in the UK*, DETR/Nirex, July 1998

EXTRACT 3: Security of Energy Supply

The UK is currently a net exporter of oil and gas. However, our demand for oil and gas is widely projected to rise by 2020, whilst domestic production is projected to fall. World reserves are widely assessed as more than sufficient to meet projected demand for oil and gas over the next few decades. However, by 2020, around a half of total oil demand will be met by countries with a high potential risk of internal instability.

Although global oil and gas reserves are projected to be sufficient to meet global demand, it is important to ensure more sustainable oil prices. Avoiding destabilising swings in oil and gas prices is in the interests of both the consumer and the producer countries. Delivering competitive, liberalised energy markets will be a key component in ensuring reliable and affordable energy supplies. There is not an explicit price target; a transparent and competitive market is the best mechanism for delivering sustainable prices.

An important part of energy security is countering potential international threats to the physical security of supplies (e.g. sabotage of oil fields, and kidnapping of key workers).

Source: *Foreign and Commonwealth Office website on International Priorities*

EXTRACT 4: Plutonium

Symbol Pu, radioactive metallic element that is used in nuclear reactors and nuclear weapons. The atomic number of plutonium is 94. The element is one of the transuranium elements in the actinide series of the periodic table.

Isotopes of plutonium were first prepared by the American chemist Glenn T. Seaborg and his associates at the University of California at Berkeley in 1940. Trace amounts of the element have since been found in uranium ores, but plutonium is prepared in relatively large quantities today in nuclear reactors. Plutonium was named after the planet Pluto.

Chemically, plutonium is reactive, its properties somewhat resembling those of the rare earth elements. The silvery metal, which becomes slightly yellow through oxidation caused by exposure to air, exists in six varying crystalline forms and has four different oxidation states. The metal gives off heat because of its radioactivity; 19 different isotopes of plutonium are known. Plutonium melts at about 641 °C (about 1186 °F) and boils at about 3228 °C (about 5842 °F). Each of plutonium's six forms has a different specific gravity; they vary from 16 to 19.9.

The most important isotope, plutonium-239, has a half-life of 24,100 years, and is produced by bombarding uranium-238 with slow neutrons. This forms neptunium-239, which in turn emits a beta particle and forms plutonium-239. Plutonium is the most economically important of the transuranium elements because plutonium-239 readily undergoes fission and can be both used and produced in quantity in nuclear reactors. It is also used in making nuclear weapons. It is an extremely hazardous poison due to its high radioactivity. Plutonium-238 has been used to power equipment on the Moon by means of the heat it emits.

Source: *MSN ENCARTA*

EXTRACT 5: Using Plutonium

A valuable source of energy

- Plutonium is produced when uranium fuel is burnt in conventional nuclear reactors. So it is present in used nuclear fuel when it leaves the reactor. If we process the used fuel, we can recycle the 96% of it that is uranium and the 1% that is plutonium to generate electricity. The reprocessing of used fuel separates the other 3% of waste products that are in the used fuel so that we can safely manage them and eventually dispose (get rid) of them in a safe and managed way. Plutonium is a valuable source of energy – one gram of plutonium used in a conventional nuclear reactor has the same energy value as over two tonnes of coal.

How poisonous is plutonium?

- Plutonium is radioactive, but the main type of radiation it gives off (alpha particles) is not very penetrating and does not pass through even thin layers of materials, such as thin rubber gloves.
- Plutonium is highly toxic if you breathe it or eat it. We take very strict protection measures at each stage of the handling process to make sure the plutonium doesn't get into the body, by breathing or eating it, or through cuts in the skin.

Making weapons from plutonium

- The plutonium used to make nuclear weapons has a high percentage of the Pu-239 isotope, which is created when reactors are run in a particular way just for the purpose of making plutonium for weapons. Plutonium that is produced when reactors are operated for civil electricity generation has a very different mixture of plutonium isotopes.
- It has been claimed that if the plutonium taken from used fuel fell into the wrong hands, it could be used to make a nuclear weapon. Plutonium that is taken out of used fuel, from civil nuclear reactors by reprocessing, is kept under strict safeguards. Nuclear weapons are not made from safeguarded plutonium, but it may still be technically possible to use the plutonium from civil reactors to manufacture an explosive device. However, anyone wanting to make this type of device would need access to safe handling facilities, a great deal of skill and specialist knowledge, and access to very special technology and parts which are not generally available. Even if all these things were available, it would take months, or even years, to make an explosive device from civil reactor plutonium, and it would be extremely difficult to do in secret.

Plutonium as a fuel

- Plutonium is a valuable source of energy. When plutonium is mixed with uranium to form a mixed oxide (MOX) fuel, (this is made up of around 95% uranium and 5% plutonium), it can be burnt in conventional nuclear reactors. About 400 tonnes of MOX fuel has been burnt in this way since 1963 and over 30 European reactors are now licensed to burn MOX fuel. Currently, reactors are licensed to load around one-third of the core with MOX fuel, making use of up to two tonnes of plutonium at any one time.
- The cost of burning MOX fuel, compared to the cost of burning conventional fuel, will change from country to country and even between individual generating companies. However, an independent study by the Organisation for Economic Cooperation and Development (OECD) has shown that MOX fuel could be up to 30% cheaper than conventional uranium fuel in certain circumstances. We have worked out that it is possible to make savings of up to £50 million over the lifetime of a new reactor by burning MOX fuel instead of conventional nuclear fuel.

Plutonium stocks

- Using MOX fuel helps us to manage the plutonium stockpile which would otherwise continue to grow if we only used conventional uranium fuel in reactors. Typical MOX fuel might contain between about 50 and 70 kilograms of plutonium for each tonne of fuel entering the reactor. After four years of generating electricity, the amount of plutonium in the fuel would have been reduced by about 18 kilograms in each tonne of fuel
- Studies by the independent International Atomic Energy Agency have shown that if MOX fuel is burnt at reasonable levels, the world's stockpile of plutonium can be held steady and then gradually reduced during the next 10 years. But this is possible only if we maintain the skills and technology we already use in the reprocessing industry.
- Disposing of nuclear weapons since the end of the cold war has made available much more plutonium. Anti-nuclear groups are using this as a reason for stopping the reprocessing of any more used fuel. A recent study by the United States National Academy of Sciences has identified two possible ways of reducing the amount of plutonium taken from nuclear weapons in the USA and former Soviet Union. One way is to immobilise the plutonium by mixing it with glass and then burying it deep underground. The other way is to convert it into MOX fuel and burn it in conventional reactors. The first option treats plutonium as a waste product and would create large amounts of radioactive waste for no useful purpose. The second option treats plutonium as a valuable source of energy and would create a great deal of electricity before the used fuel is finally disposed of as waste.

Source: BNFL information sheet

EXTRACT 6: The Greenhouse Effect

The term 'Greenhouse Effect' is commonly used to describe the increase in the Earth's average temperature that has been recorded over the past 100 years. However, without the 'natural greenhouse effect', life on Earth would be very different to that seen today.

The 'natural greenhouse effect'

The Earth receives its life-sustaining warmth from the Sun. On its way to the Earth's surface most of the heat energy passes through the Earth's atmosphere, while a smaller proportion is reflected back into space.

The energy warms the Earth's surface, and as the temperature increases, the Earth radiates heat energy (infrared energy) back into the atmosphere. As this energy has a different wavelength to that coming from the sun, some is absorbed by gases in the atmosphere.

There are four main naturally occurring gases that are responsible for the Greenhouse Effect; water vapour, carbon dioxide, methane and nitrous oxide. Once these gases absorb energy, the gas particles begin to vibrate and they radiate energy in all directions, including approximately 30% of it back towards Earth.

The other two important greenhouse gases are ozone and halocarbons.

As a result, the Earth's average surface temperature is kept at about 15 °C by the blanket of atmosphere that surrounds it. Without this, the temperature would be about -18 °C – too cold for life. The gases keep the Earth warm in a similar (but not identical) way as a greenhouse keeps plants warm.

The 'enhanced greenhouse effect'

Although most of the greenhouse gases occur naturally in the atmosphere, some are man-made and the most well-known of these are the fluorocarbons. Since the industrial revolution, human activities

have also resulted in an increase in natural greenhouse gases, especially carbon dioxide. An increase in these gases in the atmosphere enhances the atmosphere's ability to trap heat, which leads to an increase in the average surface temperature of the Earth.

Source: *The interactive greenhouse effect website (BBC weather centre)*

EXTRACT 7: UK Energy Review

The Energy Review has looked again at the role of nuclear electricity generation. Nuclear currently provides around 20% of the country's electricity needs, but most of our existing nuclear power stations are scheduled to close over the coming twenty years or so. Having considered all of the relevant issues, the Government believes that nuclear has a role to play in the future UK generating mix because of its contribution to increased diversity of energy supplies and its role as a source of low-carbon generation.

Source: *DTI – The Policy Framework for Nuclear New Build*

EXTRACT 8: The Nuclear Option

Nuclear energy in the UK: The UK operates three types of civil nuclear reactors:

- 'Magnox' reactors were the first generation of commercial nuclear reactors. They are operated by Magnox Electric (part of British Nuclear Fuels Ltd, BNFL). Some have already closed, and the remaining five are due to close by 2010.
- Advanced gas-cooled reactors (AGRs) evolved from the Magnox design. British Energy (BE) operates seven AGRs; all of which are scheduled to close between 2008 and 2023.
- Pressurised-water reactors (PWR) are a US design. BE operates one PWR, Sizewell B in Suffolk. This will close around 2035. Together, nuclear power stations in the UK meet 23% of current electricity demand: 5% from Magnox, 16% from the AGRs and 2% from the PWR. By 2020, total nuclear capacity will have reduced by around three-quarters. When built, nuclear reactors are designed to last for a specified lifetime but, in principle, it is possible to extend this. Magnox reactors have already run longer than originally expected, but further extensions of their lifetime are not economic. In 1994, BE increased the lifetime of some of its AGRs by five years. However, BE currently has no plans to extend the lifetime of its AGRs further, nor is it planning to extend the lifetime of Sizewell B.

Options for new reactors: Magnox and AGRs are no longer built anywhere and the PWR (Pressurised Water Reactor) is now the most common reactor type. Should there be new nuclear build in the UK, there are three designs which are the likeliest contenders in the short term. The first is based on a unique Canadian design while the latter two are based on PWR (Pressurised Water Reactor) technology: none has yet been built anywhere.

Each of the above reactors has been designed to operate for 60 years. They are also designed to use fuel more efficiently than previous reactors, reducing fuel use and waste. For safety, a nuclear power plant must be robust to protect the reactor core. Each of the above designs employs containment structures that include a concrete outer shield. Similarly, the reactor core needs to be cooled to prevent overheating, which could otherwise lead to releases of radiological material.

Source: *The Parliamentary Office of Science and Technology Postnotes*
December 2003 Number 208

Permission to reproduce items where third-party owned material protected by copyright is included has been sought and cleared where possible. Every reasonable effort has been made by the publisher (UCLES) to trace copyright holders, but if any items requiring clearance have unwittingly been included, the publisher will be pleased to make amends at the earliest possible opportunity.

University of Cambridge International Examinations is part of the Cambridge Assessment Group. Cambridge Assessment is the brand name of University of Cambridge Local Examinations Syndicate (UCLES), which is itself a department of the University of Cambridge.



UNIVERSITY OF CAMBRIDGE INTERNATIONAL EXAMINATIONS
Cambridge International Level 3 Pre-U Certificate
Principal Subject

PHYSICS

9792/02

Paper 2 Part A Written Paper

SPECIMEN MARK SCHEME

2 hours

MAXIMUM MARK: 100

This document consists of **6** printed pages.



Units are expected with numerical answers. Maximum one unit penalty per question.

- 1 (a) rate of change of velocity [1]
- (b) slow deceleration at start (1)
slow deceleration at finish (1)
maximum deceleration at 5 s (1) [3]
- (c) (i) area under graph [1]
- (ii) average height of graph around 10 m s^{-1} (1)
 $10 \text{ m s}^{-1} \times 10 \text{ s} = 100 \text{ m}$ (1) [2]
- (iii) smooth curve from origin (1)
well over half way by 5 s (1) [2]
- (d) sudden application of a force is required for constant deceleration (1)
jerk at the start of deceleration (1)
jerk at final stopping i.e. at 10 s (1)
smooth change of force able to be accommodated by passenger (1)
other valid point e.g. jerk as a sudden change of the force (1)
MAXIMUM 2 [2]

[Total: 11]

- 2 (a) $Q = It = 0.050 \times 4.0 \times 3600 = 720 \text{ C}$ (1)
 $E = QV$ with knowledge of what the symbols mean (1)
 $= 720 \times 6.0 = 4320 \text{ J}$ (1) [3]
- (b) chemical (potential energy) [1]
- (c) (i) $I = 4.0/48 = 0.0833 \text{ (A)}$ (1)
 $V_r = 0.5 \text{ V}$ (1)
 $r = 0.5/0.0833 = 6 \Omega$ (1) [3]
- (ii) $E = V^2t/R$ with knowledge of what the symbols mean (1)
 $= 4.0^2 \times 2700 / 48 = 900 \text{ J}$ (1) [2]
- (iii) $900/4320 = 21\%$ [1]
- (d) because the p.d. across it (4.5 – 4.0) is known only to 1 sig.fig. [1]

[Total: 11]

3	distance of fall/ m	gravitational p.e. /J	elastic p.e. /J	kinetic energy /J	
	0	54 000	0	0	
	20	42 000	0	12 000	(1)
	40	30 000	0	24 000	
	50	24 000	0	30 000	(1) (1)
	60	18 000	3300	32 700 (33 000)	(1) (1) (1)
	90	0	54 000	0	(1) (1)

[Total: 8]

4 (a) speed = $3.00 \times 10^8 \text{ m s}^{-1}$ [1]

(b) (i) for measuring across at least three waves (1)
wavelength = e.g. $0.141 \text{ m} (\pm 0.002)/4 = 0.0353 \text{ m}$ (1)
gives three significant figures (1) [3]

(ii) frequency = $c/\lambda = 3.00 \times 10^8 / 0.0353$ (1)
 $= 8.50 \times 10^9 \text{ Hz}$ (no additional sig. fig. penalty here) (1) [2]

(c) (i) both 49 cm [1]

(ii) phase difference will be zero (1)
so amplitude of resultant wave will be a maximum (1) [2]

(iii) 1. $DC = 18 \text{ cm}$, $DABC = 80 \text{ cm}$ [1]

2. path difference = 62 cm , which is $15\frac{1}{2}$ wavelengths
so waves arrive (π radians) out of phase (1)
so cancellation takes place (1) [2]

(iv) large signal from transmitter would swamp (reflected) weak signals (1)
unless they arrived at different times (1)
this cancels out the strong signal (1)
but allows the weak signal through (1)
strong signal could damage the receiver (1)
MAXIMUM 3 [3]

[Total: 15]

- 5 (a) controlled by the maximum number of photoelectrons produced (1)
this is controlled by the intensity of the illumination (1) [2]
- (b) (i) 2 eV [1]
- (ii) $E = hc/\lambda = 6.63 \times 10^{-34} \times 3.00 \times 10^8 / 328 \times 10^{-9} = (6.064 \times 10^{-19})$ (1)
conversion to eV = $6.064 \times 10^{-19} / 1.60 \times 10^{-19} = 3.79$ (eV) (1) [2]
- (iii) $E = \phi - hf$ (1)
 $\phi = 3.79 - 2.00 = 1.79$ eV (1) [2]
- (c) lower than original, horizontal on the right, still zero at -2.0 V [1]
- [Total: 8]**

- 6 (a) Kirchhoff's (first) law OR conservation of charge
OR electric current into house must equal current out of house (1)
gas supply is used in the house (chemically)
OR waste gas (combustion products) go up the chimney (1) [2]
- (b) (i) unit of Q/t is J s^{-1}
unit of A is m^2
unit of $(\theta_2 - \theta_1) / d$ is K m^{-1} (allow $^\circ\text{C m}^{-1}$) (1)
reorganise to unit of k is $\text{J s}^{-1} / \text{m}^2 \text{K m}^{-1}$ (1)
unit of $k = \text{J s}^{-1} \text{m}^{-1} \text{K}^{-1}$ OR $\text{W m}^{-1} \text{K}^{-1}$ OR $\text{kg m s}^{-3} \text{K}^{-1}$ (1) [3]
- (ii) $Q/t = 0.35 \times 12 \times (22 - 8) / 0.10$ (1)
 $= 588 \text{ J s}^{-1}$ or 588 (W) (1) [2]
- (c) (i) $Q/t = I = V/R$ $R = \rho l/A$ (1)
 $Q/t = AV/\rho l$ (1) [2]
- (ii) 1. $(\theta_2 - \theta_1)$ OR temperature difference (1)
2. $1/k$ (1) [2]
- (d) (i) $V/t = Ap/cl$ OR $m/t = Ap/cl$ OR $\frac{V}{t} = cAp/l$ OR $\frac{m}{t} = cAp/l$ (1)
where V/t is volume of gas per unit time
 m/t is mass of gas per unit time
 c is a constant and (1)
 p is the pressure difference (1) [3]
- (ii) $V_1/160 = 22^2/15^2$ (1)
 $V_1 = 160 \times 484 / 225 = 344 \text{ (cm}^3 \text{ s}^{-1}\text{)}$ (1) [2]

[Total: 16]

- 7 (a) 94 protons, 145 neutrons [1]
- (b) relates power with energy of a single alpha particle (1)
 $2.5 \text{ (W)} / 8.2 \times 10^{-13} \text{ (J)} = 3.05 \times 10^{12} \text{ Bq}$ (1)
 100% efficiency assumed (1) [3]
- (c) advantage: e.g. less mass of Pu-238 required OR activity per unit mass greater (do not allow simply 'greater energy') (1)
 disadvantage: e.g. lasts for a shorter time, non constant output (1) [2]

[Total: 6]

- 8 (a) carbon dioxide is a waste product of fossil-fuelled thermal power stations. (1)
 carbon dioxide is a greenhouse gas responsible for global warming. (1)
 more detailed information, e.g. (2)
 carbon dioxide absorbs the longer wavelength (IR) radiation from the Earth and re-radiates it thereby reducing radiation losses from the Earth and increasing atmospheric temperatures.
 MAXIMUM 3 [3]
- (b) nuclear power stations do not emit carbon dioxide. (1)
 if nuclear power stations are used instead of fossil fuelled power stations then less carbon dioxide will be released into the atmosphere. (1) [2]
- (c) many oil fields are in unstable parts of the world so supplies may be interrupted (1)
 dependence on energy sources from overseas means we have little control over the price of energy. (1)
 cost and dependability of energy supplies can be affected by (political) events (1)
 power stations can be terrorist targets (1)
 MAXIMUM 1 [1]
- (d) *Why is it hazardous?*
 radioactive waste emits ionising radiation that can cause cell damage or cancer or genetic damage(1)
 more detail of the effects of ionising radiation (1)
 difficult to isolate the waste from the environment for thousands of years (1)
 high level waste generates heat as it decays (1)
 MAXIMUM 2
- How is it dealt with at the moment?*
 low-level waste is pumped into the sea or buried in the ground (1)
 intermediate level waste is immobilised in cement and stored in (purpose-built) buildings (1)
 high level waste is turned into glass and stored in stainless steel containers (in air-cooled chambers inside purpose-built buildings) (1)
 MAXIMUM 2

Why will it remain a problem?

many of the isotopes or their decay products have long half lives(1)
 the activity of a source is proportional to the amount of the source so isotopes with long half-lives will remain active for a long time (1)
 we cannot guarantee that we can isolate the waste from the environment for long enough to allow the activity to drop to acceptable levels (1)
 MAXIMUM 2

Assessment of the Greenpeace argument

coherent argument (1)
 clear and consistent conclusion (1)

Independent research

Information or arguments not contained in the insert (2) [10]

(e) *Plutonium*

element 94 in the periodic table (1)
 it is radioactive and emits alpha-particles (1)
 it is fissile (1)
 it has a long half-life (24 110 years) (1)
 accumulates in the cores of nuclear reactors (1)
 it is created when U-238 absorbs a neutron and undergoes two beta-decays (1)
 nuclear transformation equations for creation of Pu-239 (1)
 MAXIMUM 2

Hazards

alpha-emitter so main hazard is if ingested (1)
 (plutonium compounds are) toxic (1)
 it has a low critical mass or accidental criticality can cause a large radiation dose (1)
 MAXIMUM 2

Link between civil and military nuclear power

plutonium can be extracted from spent nuclear fuel by reprocessing. (1)
 plutonium can be used in nuclear weapons (1)

Independent research

information or arguments not contained in the advance release document (3) [9]

[Total: 25]



UNIVERSITY OF CAMBRIDGE INTERNATIONAL EXAMINATIONS
Cambridge International Level 3 Pre-U Certificate
Principal Subject

CANDIDATE
NAME

CENTRE
NUMBER

--	--	--	--	--

CANDIDATE
NUMBER

--	--	--	--

PHYSICS

9792/03

Paper 3 Part B Written Paper

SPECIMEN PAPER

3 hours

Candidates answer on the Question Paper.

No Additional Materials are required.

READ THESE INSTRUCTIONS FIRST

Write your Centre number, candidate number and name on all the work you hand in.

Write in dark blue or black pen in the spaces provided.

You may use a soft pencil for any diagrams, graphs or rough working.

Do not use staples, paper clips, highlighters, glue or correction fluid.

Section A

Answer **all** questions. You are advised to spend 1½ hours on this section.

Section B

Answer any **three** questions. All six questions carry equal marks. You are advised to spend 1½ hours on this section.

You are advised to show working in all calculations.

At the end of the examination, fasten all your work securely together.

The number of marks is given in brackets [] at the end of each question or part question.

For Examiner's Use	
1	
2	
3	
4	
5	
6	
7	
8	
9	
10	
11	
12	
13	
Total	

This document consists of **32** printed pages.



Data

gravitational field strength close to Earth's surface	$g = 9.81 \text{ N kg}^{-1}$
elementary charge	$e = 1.60 \times 10^{-19} \text{ C}$
speed of light in vacuum	$c = 3.00 \times 10^8 \text{ m s}^{-1}$
Planck constant	$h = 6.63 \times 10^{-34} \text{ J s}$
permittivity of free space	$\epsilon_0 = 8.85 \times 10^{-12} \text{ F m}^{-1}$
gravitational constant	$G = 6.67 \times 10^{-11} \text{ N m}^2 \text{ kg}^{-2}$
electron mass	$m_e = 9.11 \times 10^{-31} \text{ kg}$
proton mass	$m_p = 1.67 \times 10^{-27} \text{ kg}$
unified atomic mass constant	$u = 1.66 \times 10^{-27} \text{ kg}$
molar gas constant	$R = 8.31 \text{ J K}^{-1} \text{ mol}^{-1}$
Avogadro constant	$N_A = 6.02 \times 10^{23} \text{ mol}^{-1}$
Boltzmann constant	$k = 1.38 \times 10^{-23} \text{ J K}^{-1}$
Stefan-Boltzmann constant	$\sigma = 5.67 \times 10^{-8} \text{ W m}^{-2} \text{ K}^{-4}$

Formulae

uniformly accelerated motion	$s = ut + \frac{1}{2} at^2$ $v^2 = u^2 + 2as$ $s = \left(\frac{u+v}{2} \right) t$
heating	$\Delta E = mc\Delta\theta$
change of state	$\Delta E = mL$
refraction	$n = \frac{\sin \theta_1}{\sin \theta_2}$ $n = \frac{v_1}{v_2}$
photon energy	$E = hf$
de Broglie wavelength	$\lambda = \frac{h}{p}$
simple harmonic motion	$x = A \cos \omega t$ $v = -A\omega \sin \omega t$ $a = -A\omega^2 \cos \omega t$ $F = -m\omega^2 x$ $E = \frac{1}{2} mA^2\omega^2$

energy stored in a capacitor	$W = \frac{1}{2} QV$
electric force	$F = \frac{Q_1 Q_2}{4\pi\epsilon_0 r^2}$
electrostatic potential energy	$W = \frac{Q_1 Q_2}{4\pi\epsilon_0 r}$
gravitational force	$F = \frac{-Gm_1 m_2}{r^2}$
gravitational potential energy	$E = \frac{-Gm_1 m_2}{r}$
magnetic force	$F = BIl \sin \theta$ $F = BQv \sin \theta$
electromagnetic induction	$E = \frac{-d(N\Phi)}{dt}$
Hall effect	$V = Bvd$
time dilation	$t' = \frac{t}{\sqrt{1 - \frac{v^2}{c^2}}}$
kinetic theory	$\frac{1}{2} m\langle c^2 \rangle = \frac{3}{2} kT$
work done on/by a gas	$W = p\Delta V$
radioactive decay	$\frac{dN}{dt} = -\lambda N$ $N = N_0 e^{-\lambda t}$ $t_{\frac{1}{2}} = \frac{\ln 2}{\lambda}$
attenuation losses	$I = I_0 e^{-\mu x}$
mass-energy equivalence	$\Delta E = c^2 \Delta m$
hydrogen energy levels	$E_n = \frac{-13.6 \text{ eV}}{n^2}$
Heisenberg uncertainty principle	$\Delta p \Delta x \geq \frac{h}{2\pi}$ $\Delta E \Delta t \geq \frac{h}{2\pi}$
Wien's law	$\lambda_{\text{max}} \propto \frac{1}{T}$
Stefan's law	$L = 4\pi\sigma r^2 T^4$
electromagnetic radiation from a moving source	$\frac{\Delta\lambda}{\lambda} \approx \frac{\Delta f}{f} \approx \frac{v}{c}$

Section A

For
Examiner's
Use

Answer **all** questions in this section.
You are advised to spend 1½ hours on this section.

- 1 (a) Write down an equation expressing Newton's law of gravitation. Define your symbols.

[2]

- (b) Use the equation in (a) to derive a value for g , the acceleration due to gravity, at the Earth's surface.

mass of Earth = 5.98×10^{24} kg
mean radius of Earth = 6.37×10^6 m

$g =$ [3]

- (c) A geostationary satellite has to be placed above the equator.

- (i) State what is meant by *geostationary*.

.....
..... [1]

- (ii) State the direction of rotation of the satellite around the Earth's axis.

..... [1]

- (iii) Explain why the satellite must be above the equator.

.....
..... [2]

(d) A geostationary satellite is in orbit at a distance of 4.23×10^7 m from the centre of the Earth. Calculate

(i) the Earth's gravitational field strength at this distance from the centre of the Earth,

gravitational field strength = [1]

(ii) the speed of the satellite,

speed = [3]

(iii) the acceleration of the satellite.

acceleration = [2]

(e) In the data, g is given as 9.81 N kg^{-1} .

Compare and comment on small differences between this value, the value you obtained in part (b) and the value 9.79 m s^{-2} which is obtained for the acceleration of free fall on the equator.

.....
.....
.....
..... [4]

[Total: 19]

- 2 This question is about the discharge of combinations of capacitors.

For
Examiner's
Use

In Fig. 2.1 and Fig. 2.2, the capacitors are charged through a $10\text{ k}\Omega$ resistor from a 10 V d.c. supply when the switch S is connected to X . They discharge when the switch is moved to Y . The ammeters monitor the currents in the circuits. Initially, the switch is connected to X and the capacitors are fully charged.

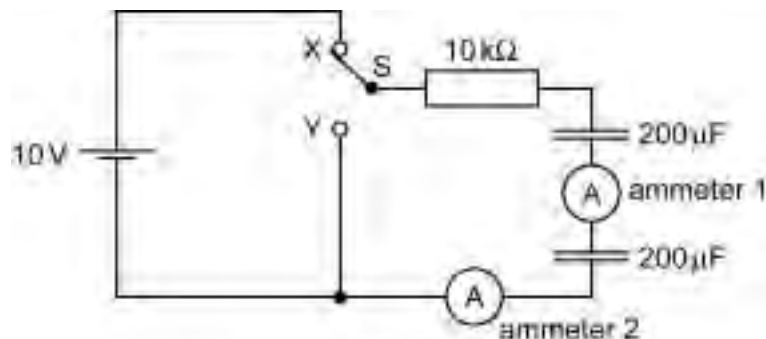

Fig. 2.1

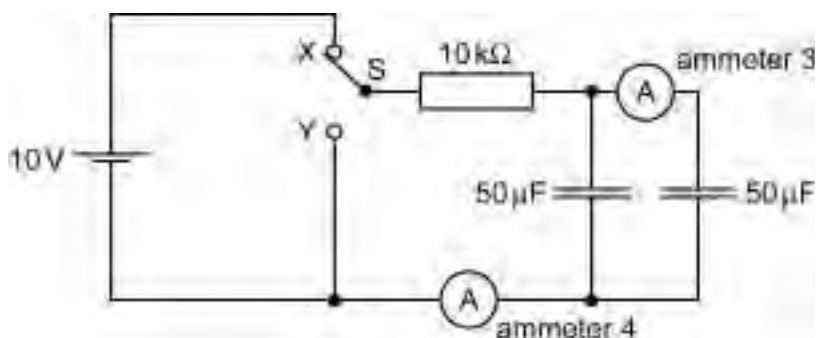

Fig. 2.2

- (a) State the potential difference across each capacitor

- (i) in Fig. 2.1,

potential difference = V [1]

- (ii) in Fig. 2.2.

potential difference = V [1]

- (b) (i) Calculate the total charge stored in the circuit of Fig. 2.2.

charge = [2]

- (ii) Explain why the total charge stored in the circuit of Fig. 2.1 is the same as in the circuit of Fig. 2.2.

For
Examiner's
Use

.....

.....

.....

..... [2]

- (c) The switches in both circuits are moved from X to Y at time $t = 0$. Fig. 2.3 shows how the reading I on ammeter 2 varies with time t as the capacitors discharge.

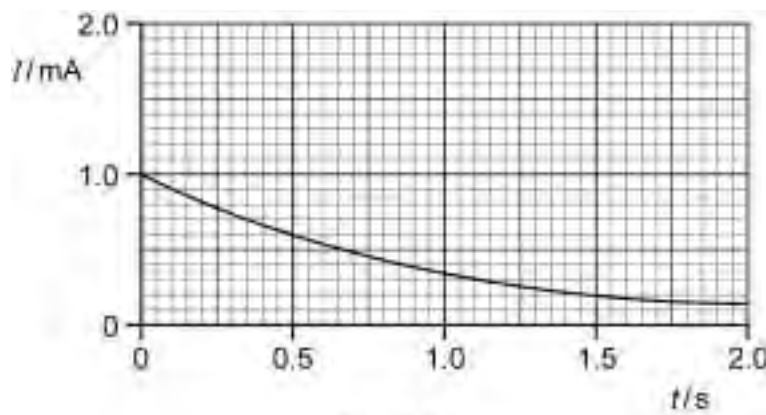

Fig. 2.3

- (i) Describe how and explain why the reading on ammeter 1 varies, if at all, over the same time interval.

.....

.....

..... [2]

- (ii) Sketch curves on Fig. 2.3 to show how you expect the readings on ammeters 3 and 4 to vary with time. Label your curves ammeter 3 and ammeter 4 respectively.

[3]

[Total: 11]

- 3 Fig. 3.1 shows an evacuated circular tube in which charged particles can be accelerated. A uniform magnetic field B acts in a direction perpendicular to the plane of the tube. Protons move with a speed v along a circular path within the tube.

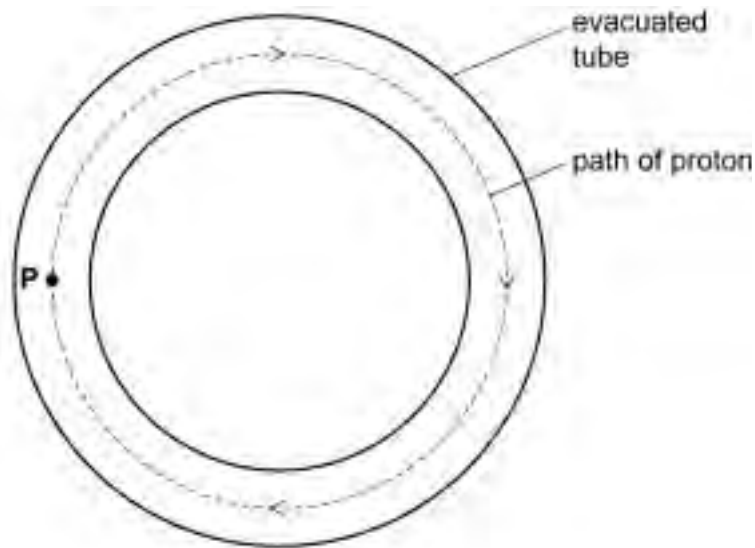

Fig. 3.1

- (a) On Fig. 3.1, draw an arrow at P to indicate the direction of the force on the protons for them to move in a circle within the tube. [1]

- (b) State the direction of the magnetic field. Explain how you arrived at your answer.

.....
 [2]

- (c) Write down an algebraic expression for the force F on a proton in terms of the flux density B at point P and the speed v of the proton.

[1]

- (d) Calculate the value of B needed to contain protons of speed $1.5 \times 10^7 \text{ m s}^{-1}$ within a tube of radius 60 m. Give the unit for your answer.

$$B = \text{.....} [4]$$

- (e) State and explain what action must be taken to contain protons injected into the tube at twice the speed.

.....
 [2]

[Total: 10]

- 4 (a) Explain what is meant by the *internal energy* of a gas.

.....

 [2]

- (b) Assume argon gas at a temperature of 300 K behaves ideally. An atom of argon gas has mass 6.6×10^{-26} kg.

- (i) Show that 0.020 kg of argon contains 3.0×10^{23} atoms.

[1]

- (ii) The average speed of an argon atom at this temperature is 440 m s^{-1} . Determine the kinetic energy of an argon atom travelling at this speed.

kinetic energy = [2]

- (iii) The kinetic energy of an alpha-particle from a radioactive source is 4.3 MeV. Calculate the ratio of the kinetic energy of the alpha-particle to the kinetic energy of the argon atom in (ii).

ratio = [3]

- (c) Not all the argon atoms have the same speed. The distribution of speeds is shown in Fig. 4.1.

For
Examiner's
Use

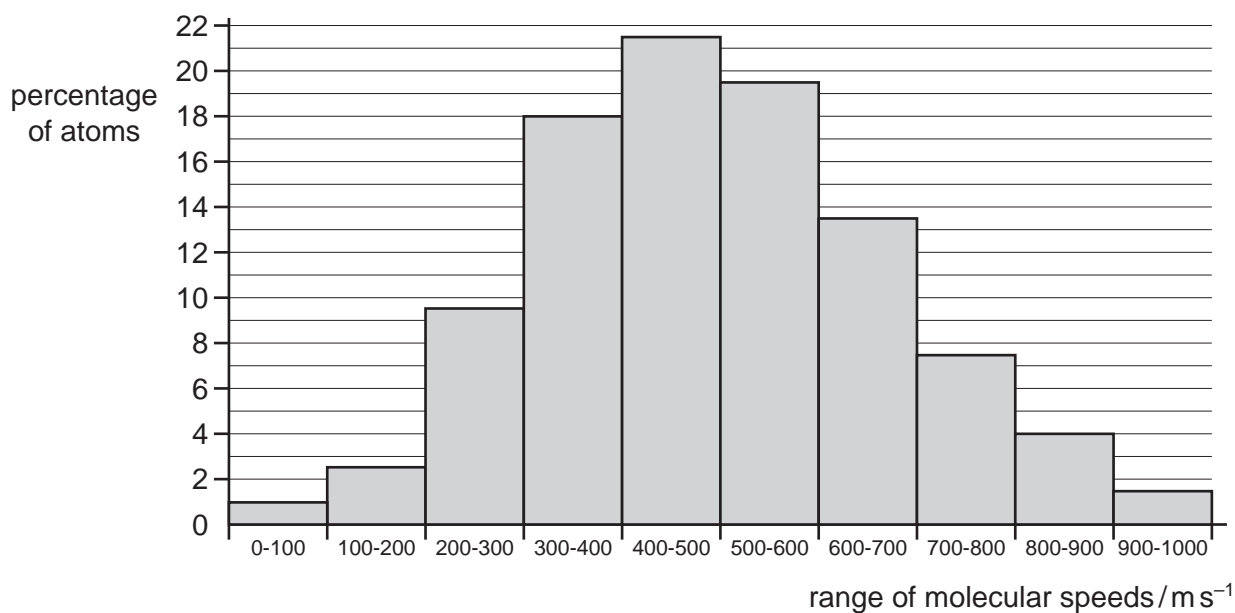

Fig. 4.1

The argon sample contains 3.0×10^{23} atoms.

- (i) Show that the number of atoms in the sample having speeds between 500 m s^{-1} and 600 m s^{-1} is about 6×10^{22} .

[1]

- (ii) Show that about 1×10^{22} atoms have speeds less than 200 m s^{-1} .

[1]

- (iii) Find the total percentage of all the columns shown in the histogram and use your answer to find the total number of atoms with speeds greater than 1000 m s^{-1} .

number of atoms = [2]

- (iv) Approximately what percentage of atoms are travelling at more than twice the average speed of 440 m s^{-1} ?

percentage of atoms = [2]

- (d) Fig. 4.2 shows the outline of the histogram in Fig 4.1.

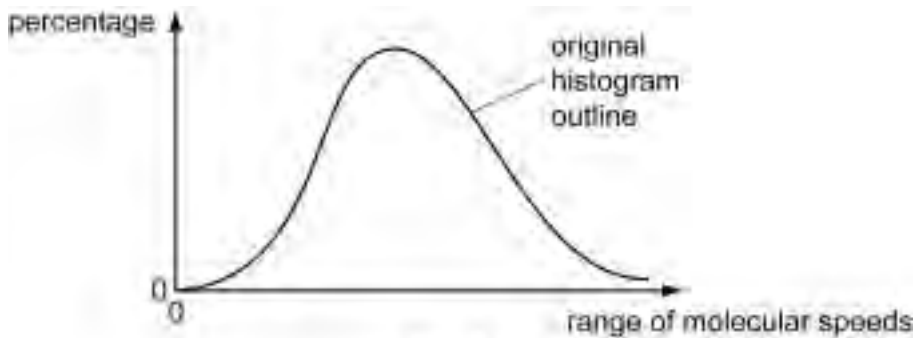

Fig. 4.2

By drawing a line on Fig. 4.2, illustrate how the outline of the histogram would change if the temperature of the argon were increased. [1]

- (e) Explain, in terms of particle behaviour, why the temperature of a liquid falls due to evaporation.

.....

[2]

[Total: 17]

- 5 (a) (i) State the charge, in terms of the elementary charge e , on the up quark and the down quark.

up quark charge =

down quark charge =

[1]

- (ii) State the quark composition of the proton and the neutron.

proton =

neutron =

[1]

- (b) The π^+ is a particle that can be produced in a reaction between two protons, as shown in the equation below.

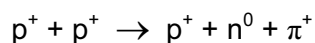

- (i) Simplify this equation and, using your answers to (a), write the equation in terms of quarks.

[2]

- (ii) The π^+ consists of a quark and an anti-quark. Use your answer to (i) to deduce the quark composition of the π^+ particle.

[2]

[Total: 6]

For
Examiner's
Use

6 A radioactive material is known to contain a mixture of two nuclides X and Y of different half-lives. Readings of activity, taken as the material decays, are given in the table, together with the activity of nuclide X over the first 12 hours.

time / hour	activity of material / Bq	activity of nuclide X / Bq	activity of nuclide Y / Bq
0	4600	4200	400
6	3713	3334	
12	3002	2646	
18	2436		
24	1984		
30	1619		
36	1333		

(a) The half-life of nuclide X is 18 hours. Complete the table. [4]

(b) Calculate the half-life of nuclide Y.

half-life = [3]

(c) Explain why it is **not** possible to give a half-life for a **mixture** of two nuclides.

.....

.....

.....

.....

.....

[3]

[Total: 10]

7 The Earth has a radius of 6.4×10^6 m. When viewed from the Sun, the Earth looks like a disc. Each square metre of the Earth's disc receives 1100 joules per second from the Sun.

(a) Show that the total amount of energy the Earth receives from the Sun every second is 1.42×10^{17} J.

[1]

(b) The Earth's mean temperature is 286 K. The Earth may be thought of as a black body radiating energy according to Stefan's law.

Calculate the total amount of energy which the Earth radiates each second.

energy per second = [2]

(c) Comment on the relative sizes of your answers to (a) and (b) in relation to

(i) factors which may not have been considered,

.....
.....
.....
.....
.....
..... [2]

(ii) global warming.

.....

.....

.....

.....

.....

*For
Examiner's
Use*

[2]

[Total: 7]

Section B

For
Examiner's
Use

Answer any **three** questions.
You are advised to spend 1½ hours on this section.

- 8 A bus uses a spinning flywheel which is brought up to full rotational speed by a motor when the bus stops at a station. The flywheel is a solid cylinder of mass 900 kg and diameter 2.2 m. Its maximum angular velocity is 2800 revolutions per minute.

(a) Calculate the angular velocity in rad s^{-1} .

angular velocity = rad s^{-1} [2]

(b) Calculate the maximum speed of particles on the rim of the spinning flywheel.

maximum speed = [2]

(c) Fig. 8.1 shows a cylinder of radius R and length L and of density ρ .

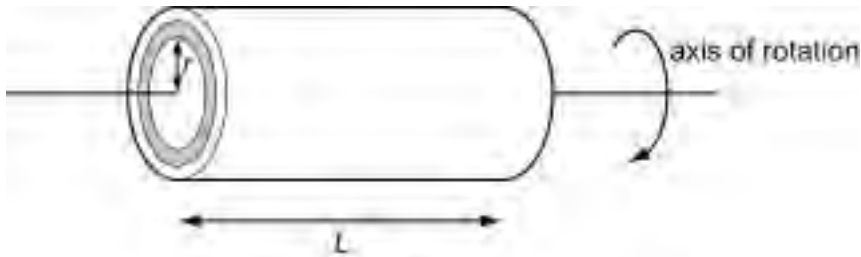

Fig. 8.1

The cylinder contains a small cylindrical shell of radius r and thickness δr . Show that the mass of the small cylindrical shell is given by

$$\delta m = 2\pi r \delta r L \rho.$$

[2]

(d) By integration show that the moment of inertia I of the whole cylinder is given by

$$I = \frac{1}{2}MR^2$$

where M is the mass of the cylinder.

[4]

(e) The cylinder has mass 900 kg and diameter 2.2 m.
Calculate the moment of inertia of the cylinder.

$I =$ [2]

(f) Calculate the maximum rotational kinetic energy of the flywheel.

maximum rotational kinetic energy = [2]

(g) The flywheel is brought up to maximum speed at a station by a motor connected to an overhead power line. The electric power is then disconnected and the energy stored in the flywheel is used to drive the bus. The average power required to operate the bus is 2.0×10^4 W. For how many minutes can the bus operate between stops?

time between stops = minutes [3]

*For
Examiner's
Use*

(h) To increase the time between stops, the flywheel needs to store more kinetic energy. It is suggested that the flywheel dimensions and angular velocity remain the same, but a material with 20% larger density be used.

(i) What would be the new time between stops if the same average power were used to operate the bus?

time between stops = minutes [1]

(ii) Give two reasons why the new flywheel might reduce the performance of the bus.

1.

.....

2.

..... [2]

[Total: 20]

- 9 Fig. 9.1 illustrates the lowest energy levels of the hydrogen atom. It gives the principal quantum number n for each energy level and the energy E_n associated with each.

For
Examiner's
Use

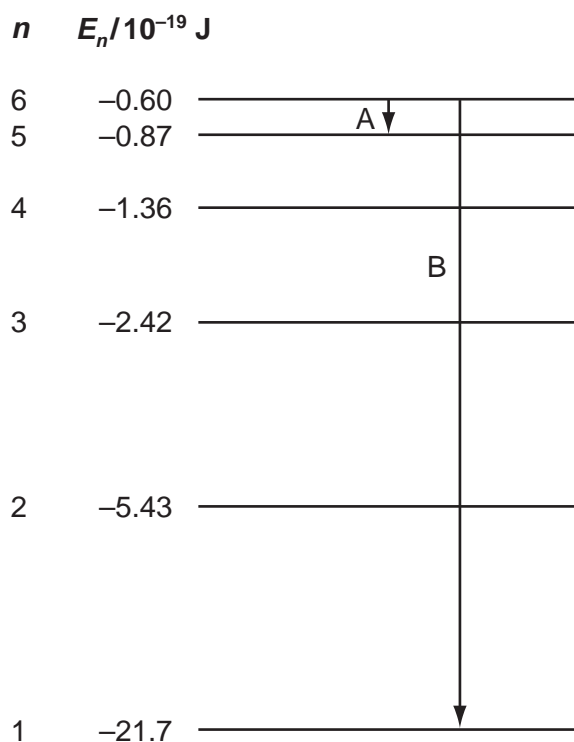

Fig. 9.1

The two arrows A and B show transitions that produce photons in the ultraviolet and infra-red parts of the spectrum.

- (a) State and explain which transition is likely to produce a line in the infra-red part of the spectrum.

.....
..... [1]

- (b) Calculate the wavelength of the line due to the transition from $n = 6$ to $n = 2$.

wavelength = [2]

(c) Explain what happens when an electron in the ground state is struck by a photon of frequency 3.27×10^{15} Hz.

.....
.....
.....
.....
.....
..... [3]

(d) Convert 21.7×10^{-19} J to electron-volts.

21.7×10^{-19} J = eV [1]

(e) Calculate E_n in joules for $n = 7$.

$E_n =$ J [2]

(f) Niels Bohr postulated that the electron in a hydrogen atom can only exist in discrete orbits. Each orbit has a certain value of energy. This idea was later explained by imagining standing waves for the electron.

(i) What is a standing wave?

.....
.....
.....
..... [3]

- (ii) If an electron standing wave fits into an atom of radius r , then the largest wavelength is $2\pi r$.

Derive an expression, in terms of r , for the momentum of the electron.

For
Examiner's
Use

[2]

- (iii) Show that the total energy of the atom is given by

$$\frac{h^2}{8\pi^2 m_e r^2} - \frac{1}{4\pi\epsilon_0} \frac{e^2}{r}$$

where m_e is the mass of the electron and e is the elementary charge.

[2]

- (iv) When the total energy is a minimum, the electron will be in a stable energy level. By differentiation of the expression in (iii) with respect to r , show that this occurs when $r = 5.3 \times 10^{-11}$ m.

[4]

[Total: 20]

10 The front wheel and suspension system of a car are shown in Fig. 10.1.

For
Examiner's
Use

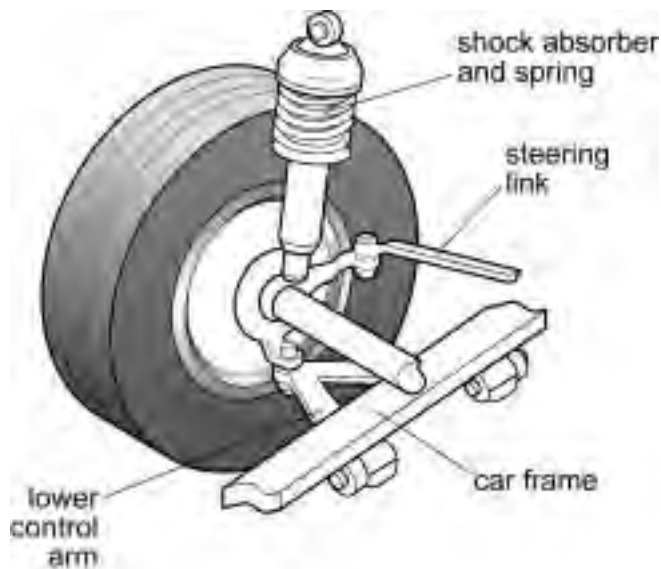

Fig. 10.1

A driver of mass 75 kg sits over one of the wheels and the spring in the suspension system compresses by 2.0×10^{-2} m.

(a) Show that the spring constant of the spring suspension system is about 40 kN m^{-1} .

[2]

(b) The suspension system is modelled as a mass m suspended from a spring of constant k , as shown in Fig. 10.2.



Fig. 10.2

Show that when displaced by x from equilibrium, the acceleration a of the mass is given by

$$a = \frac{-k}{m} x.$$

[2]

- (c) By comparing with $\frac{d^2x}{dt^2} = -\omega^2x$, find an equation for the natural frequency of oscillation f in terms of k and m .

For
Examiner's
Use

[2]

- (d) Show that $x = A \cos \omega t$ is a solution of the equation $\frac{d^2x}{dt^2} = -\omega^2x$.

[2]

- (e) At time $t = 0$ s, the suspension system has an effective mass of 150 kg and is released from an initial displacement $A = 1.0 \times 10^{-2}$ m. Calculate

- (i) the value of ω ,

$$\omega = \dots\dots\dots [1]$$

- (ii) the displacement after 1.0 second.

$$\text{displacement} = \dots\dots\dots [2]$$

(f) Calculate

(i) the maximum acceleration,

maximum acceleration = [2]

(ii) the maximum velocity,

maximum velocity = [2]

(iii) the maximum energy of the system.

maximum energy = [2]

(g) The car travels over speed bumps 6 m apart. Determine the speed of the car at which maximum amplitude occurs.

speed = [3]

[Total: 20]

11 In this question you will be asked to explain and interpret the second law of thermodynamics.

(a) Give statements of the first and second laws of thermodynamics.

first law:

.....

.....

second law:

.....

..... [4]

(b) (i) Explain why, when considered in isolation, living creatures *appear* to violate the second law of thermodynamics.

.....

.....

..... [2]

(ii) Explain how even living things are in fact consistent with the second law of thermodynamics.

.....

.....

..... [2]

(d) Explain how the second law of thermodynamics leads to the concept of a thermodynamic 'arrow of time' and discuss whether Physics provides any other ways of distinguishing the future from the past.

*For
Examiner's
Use*

.....

.....

.....

.....

.....

.....

.....

.....

.....

.....

.....

[4]

[Total: 20]

12 Newton thought that space and time are absolute.

(a) Explain what is meant by *absolute time* and *absolute space*.

absolute time:

.....

.....

absolute space:

.....

..... [4]

(b) Fig. 12.1 shows how light reaches the Earth from a distant star at different times of the year (positions A and B). The speed of the Earth in its orbit is v and the speed of light is c .

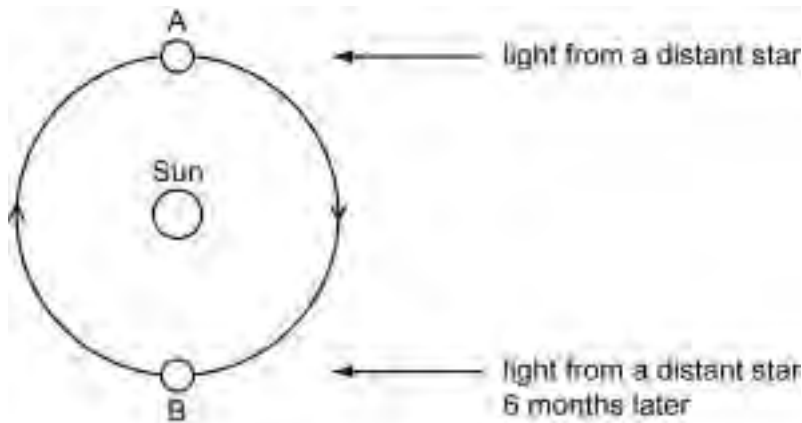

Fig. 12.1

(i) When physicists first started thinking about the speed of light, they thought space and time were absolute. Use this assumption to predict the speed of light relative to the Earth at A and at B.

.....

.....

..... [2]

(ii) State Einstein's principle of relativity and use it to make a different prediction about the measured speed of light at A and B.

.....

.....

..... [2]

- (c) Mu-mesons are unstable subatomic particles created by cosmic rays at about 60 km above the surface of the Earth, as shown in Fig. 12.2. They travel through the atmosphere at 99.95% of the speed of light. Mu-mesons at rest in a laboratory have a half-life of about $2 \mu\text{s}$.

For
Examiner's
Use

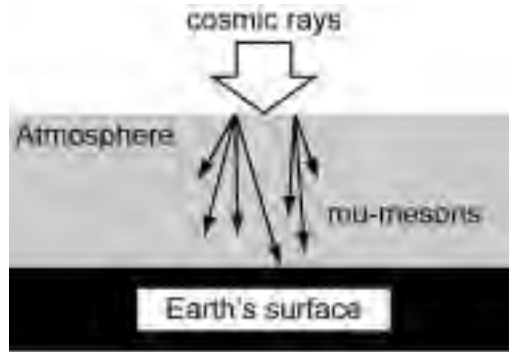

Fig. 12.2

An experiment is set up to compare the rate of arrival R_s of mu-mesons at the surface with their rate of creation R_{60} at 60 km above the surface.

Use the information above to compare the ratio R_s/R_{60} calculated using Newton's concept of absolute space and time, compare it with the same ratio calculated using Einstein's principle of relativity, and explain why the two predictions differ.

.....

.....

.....

.....

.....

.....

.....

.....

.....

.....

[12]

[Total: 20]

- 13 An experiment is carried out to demonstrate the interference of light when it passes through a barrier with two parallel narrow slits. A detector is placed beyond the double slits as shown in Fig. 13.1.

For
Examiner's
Use

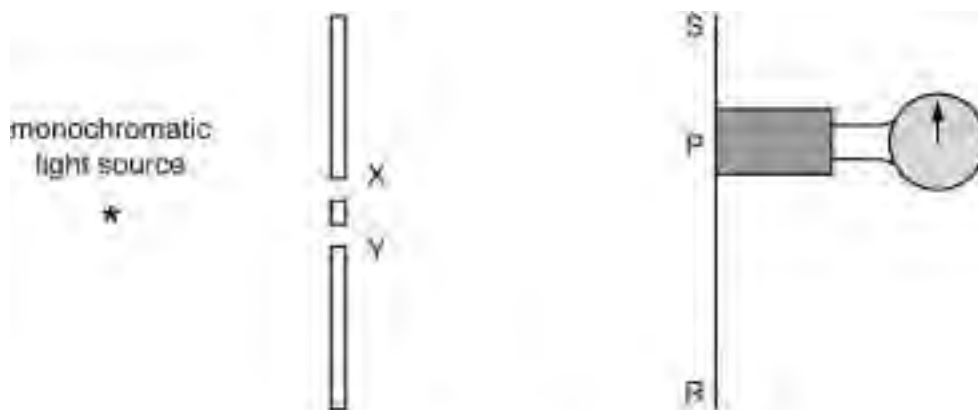

Fig. 13.1

The following experiments are carried out.

1. Slit Y is covered. The amplitude of light reaching the detector when it is placed at position P is A.
 2. Slit X is covered. The amplitude of light reaching the detector when it is placed at position P is again A.
 3. Both slits are opened. The amplitude of light reaching P is zero.
- (a) Use a **wave model** to explain how less light can arrive at P with both slits open than arrives with just one slit open.

.....

.....

.....

.....

.....

.....

.....

.....

[4]

- (b) When both slits are open and the detector is moved along the line RS, it records regular maxima and minima. P is one of the minima. In practice the detector clicks every time a photon arrives.

Explain how the Copenhagen interpretation of quantum theory can be used to predict the rate of arrival of photons at the detector.

.....

.....

.....

.....

.....

.....

.....

.....

.....

.....

..... [4]

- (c) The experiment is now modified. A filter is placed in front of the source to reduce the intensity of light reaching the apparatus. Now photons pass through the apparatus one at a time at large intervals.

A photon reaches the apparatus and passes through slit X. Explain why a second photon, approaching the apparatus in exactly the same way, might pass through slit Y.

.....

.....

..... [2]

- (d) State the probability that the photon arrives at P.

.....

..... [1]

- (e) Slit X is covered. How does this affect the probability that the photon reaches P? Explain your answer.

.....

.....

.....

..... [3]

- (f) Newtonian mechanics is deterministic but quantum theory is not. Use examples to explain what this means and to discuss whether this makes a significant difference to our ability to predict the future.

*For
Examiner's
Use*

.....

.....

.....

.....

.....

.....

.....

.....

.....

.....

[6]

[Total: 20]

Permission to reproduce items where third-party owned material protected by copyright is included has been sought and cleared where possible. Every reasonable effort has been made by the publisher (UCLES) to trace copyright holders, but if any items requiring clearance have unwittingly been included, the publisher will be pleased to make amends at the earliest possible opportunity.

University of Cambridge International Examinations is part of the Cambridge Assessment Group. Cambridge Assessment is the brand name of University of Cambridge Local Examinations Syndicate (UCLES), which is itself a department of the University of Cambridge.



UNIVERSITY OF CAMBRIDGE INTERNATIONAL EXAMINATIONS
Cambridge International Level 3 Pre-U Certificate
Principal Subject

PHYSICS

9792/03

Paper 3 Part B Written Paper

SPECIMEN MARK SCHEME

3 hours

MAXIMUM MARK: 140

This document consists of **12** printed pages.



Units are required with numerical answers: maximum 1 unit penalty per question.

Section A

- 1 (a) $F = GM_1M_2/r^2$ (1)
 G is the gravitational constant, F is the force (of attraction) between masses M_1 and M_2 when (their centres) are a distance r apart (1) [2]
- (b) $F/m = g = GM_E/r^2$ (1)
 $= 6.67 \times 10^{-11} \times 5.98 \times 10^{24} / (6.37 \times 10^6)^2$ (1)
 $= 9.83 \text{ m s}^{-2}$ (1) [3]
- (c) (i) rotating with the Earth so it appears stationary [1]
(ii) west to east [1]
(iii) the attraction to the Earth is to its centre (1)
so the circular orbit must be centred on the Earth's centre (1)
any such circle not on the equator will have a varying latitude (1)
MAXIMUM 2 [2]
- (d) (i) $g' = 6.67 \times 10^{-11} \times 5.98 \times 10^{24} / (4.23 \times 10^7)^2 = 0.223 \text{ N kg}^{-1}$ OR m s^{-2} [1]
(ii) distance = $2\pi r = 2.66 \times 10^8 \text{ m}$ (1)
time = $24 \times 3600 = 86\,400 \text{ s}$ (1)
speed = 3080 m s^{-1} (1) [3]
(iii) acceleration = $v^2/r =$ (1)
 $1.020 \times 10^7 / 4.23 \times 10^7 = 0.223 \text{ m s}^{-2}$ (1) [2]
- (e) 9.83 is the acceleration towards the centre of the Earth (1)
caused by gravitational attraction (1)
it is the acceleration of free fall at the poles therefore (1)
at all other places the acceleration towards the Earth's surface is less (1)
because the Earth's surface is accelerating (1)
9.81 is the value in England (1)
9.79 on the Equator is a lower value because some of an object's weight is causing the object's acceleration in a circle (1)
MAXIMUM 4 [4]

[Total: 19]

- 2 (a) (i) 5 (1) [1]
 (ii) 10 (1) [1]
- (b) (i) $Q = VC$ (for each capacitor) (1)
 1.0 mC (1) [2]
- (ii) In Fig. 3.2 each capacitor has twice the p.d. but half the capacitance (1)
 $Q = VC$ so same Q on all capacitors (1) [2]
- (c) (i) reading on 1 = reading on 2 (1)
 because they are in series (1) [2]
- (ii) 4 graph identical to printed 1 graph (1)
 3 graph half the current of the printed 1 graph at $t = 0$ (1)
 And at all other times (1) [3]

[Total: 11]

- 3 (a) arrow pointing towards centre of circle [1]
- (b) out of page (accept upwards) (1)
 Fleming's left hand rule named, stated or described (1) [2]
- (c) $F = Bev$ or $F = BQv$ [1]
- (d) $F = mv^2/r$ (1)
 $B = mv/er$ or $(1.67 \times 10^{-27} \times 1.5 \times 10^7)/(1.60 \times 10^{-19} \times 60)$ (1)
 2.61×10^{-3} (1)
 T (1) [4]
- (e) double the (magnetic) field strength (1)
 (for a circular path) B is proportional to v (1) [2]

[Total: 10]

- 4 (a) the sum of the kinetic and potential energies of all the atoms (in the gas) (1)
inclusion of the word 'random' when applied to energies (1) [2]
- (b) (i) total mass / mass of one atom = $0.020 \text{ (kg)} / 6.6 \times 10^{-26} \text{ (kg)}$ (1)
= 3.03×10^{23} atoms (0) [1]
- (ii) kinetic energy = $\frac{1}{2} \times 6.6 \times 10^{-26} \times (440)^2$ (1)
= $6.39 \times 10^{-21} \text{ J}$ (1) [2]
- (iii) $1 \text{ eV} = 1.6 \times 10^{-19} \text{ J}$ (1)
 $4.3 \text{ MeV} = 6.88 \times 10^{-13} \text{ J}$ (1)
ratio required = $6.88 \times 10^{-13} / 6.39 \times 10^{-21} = 1.08 \times 10^8$ (1) [3]
- (c) (i) $19.5\% \text{ of } 3.0 \times 10^{23} (= 5.85 \times 10^{22})$ [1]
- (ii) $1\% + 2\frac{1}{2}\% = 3\frac{1}{2}\%$, $3\frac{1}{2}\% \text{ of } 3.0 \times 10^{23} (= 1.05 \times 10^{22})$ [1]
- (iii) total is 98.5% (1)
 $1.5\% \text{ of } 3.0 \times 10^{23} = 4.5 \times 10^{21}$ (1) [2]
- (iv) twice average speed = 880 m s^{-1}
percentage less than $900 \text{ m s}^{-1} = 97\%$ (1)
percentage between 880 m s^{-1} and 900 m s^{-1} about 0.8%
giving $3.8\% = \text{approx. } 4\%$ (1) [2]
- (d) sketch shows more atoms at higher speed and fewer atoms at lower speed [1]
- (e) faster atoms escape more readily (than slow ones) (1)
average KE of atoms limited to temperature (1) [2]

[Total: 17]

- 5 (a) (i) up quark charge = $+\frac{2}{3} (e)$, down quark charge = $-\frac{1}{3} (e)$ [1]
- (ii) proton $u u d$: neutron $u d d$ [1]
- (b) (i) $p^+ \rightarrow n^0 + \pi^+$ (1)
 $\begin{matrix} u & u \\ u & \rightarrow d + \pi^+ \\ d & d \end{matrix}$ (1) [2]
- (ii) d must have antiparticle \bar{d} (1)
 u must be added to give composition of $u\bar{d}$ (1) [2]

[Total: 6]

6 (a)	time / hour	activity of material / Bq	activity of nuclide X / Bq	activity of nuclide Y / Bq
	0	4600	4200	400
}	6	3713	3334	379
	12	3002	2646	356
}	18	2436	2100 (1)	336
	24	1984	1667	317
}	30	1619	1323 (1)	296
	36	1333	1050	283

[4]

(b) $A = A_0 e^{-\lambda t}$ (1)

$\ln A = \ln A_0 - \lambda t$ (1)

$t_{\frac{1}{2}} = \ln 2 / \lambda = 69.0 \text{ h}$ answers will vary slightly dependent on starting and finishing times (1) [3]

(c) decay constants or half lives are different (1)

half-life at the start is approximately that for X (1)

X decays more rapidly than Y so after a long time the half-life is that for Y (1)

in between it has a value intermediate between the two (which varies) (1)

MAXIMUM 3

[3]

OR

dealt with mathematically, along the lines of

two separate exponential decays (1)

when added together do not give an exponential graph (1)

with back up maths (1)

[3]

[Total: 10]

7 (a) energy per second = $\pi r^2 \times 1100 = \pi \times (6.4 \times 10^6)^2 \times 1100 = 1.42 \times 10^{17} \text{ J (s}^{-1}\text{)}$ [1]

(b) $L = 4\pi \times 5.7 \times 10^{-8} \times (6.4 \times 10^6)^2 \times 286^4$ (1)
 $L = 1.96 \times 10^{17} \text{ J (s}^{-1}\text{)}$ (1) [2]

(c) (i) e.g. Earth is not a black body (so radiates less than this) (1)
 Earth reflects some of the radiation falling on it (1)
 some energy comes from radioactive rocks (1)
 some energy comes from Earth's core (1)
 the Earth's temperature is not all at 286 K and since the temperature is raised to the fourth power this will make a considerable difference (1)
 MAXIMUM 2 [2]

(ii) there must be an approximate balance between the two figures or (1)
 the Earth's temperature would rise or fall more quickly (1)
 OR
 for there to be no global warming the two figures must be equal (1)
 since some global warming is occurring the net energy coming in must be larger than the net energy going out (over a period of time) (1) [2]

[Total: 7]

Section B

- 8 (a) $\omega = \left(2800 \frac{\text{rev}}{\text{min}}\right) \times \left(\frac{2\pi \text{ rad}}{1 \text{ rev}}\right) \left(\frac{1 \text{ min}}{60 \text{ s}}\right)$ (1)
 293 rad s^{-1} (1) [2]
- (b) $v = \omega r$ or $293 \text{ s}^{-1} \times 1.1 \text{ m}$ (1)
 322 m s^{-1} (1) [2]
- (c) volume = $2\pi r \delta r L$ (1)
mass = volume x density (1)
 $\delta m = 2\pi r \delta r L \rho$ (0) [2]
- (d) $I = \int_{r=0}^{r=R} m r^2 dm$ (1)
 $= 2\pi L \rho \int_{r=0}^{r=R} r^3 dr$ (1)
 $= \frac{1}{2} \pi R^2 \rho L R^2$ (1)
 $M = \pi R^2 L \rho$ (1)
 $I = \frac{1}{2} M R^2$ (0) [4]
- (e) $= \frac{1}{2} \times 900 \times (1.1)^2$ (1)
 $= 545 \text{ kg m}^2$ (1) [2]
- (f) KE = $\frac{1}{2} M R^2 \omega^2$ or $\frac{1}{2} \times 900 \times (1.1)^2 \times (293)^2$ (1)
 $= 4.67 \times 10^7 \text{ J}$ (1) [2]
- (g) average power = $\frac{\text{rotational KE}}{\text{time}}$ (1)
time = $\frac{4.67 \times 10^7 \text{ J}}{2.0 \times 10^4 \text{ Js}^{-1}}$ (1)
38.9 minute (1) [3]
- (h) (i) 46.7 minutes [1]
(ii) takes longer for the motor to bring it up to full speed at each stop (1)
mass of the bus increases, reducing acceleration and deceleration (1) [2]

[Total: 20]

- 9 (a) infra-red is the lower of the two frequencies **and** its photon will have low energy due to a small energy transition ($\Delta E = hf$) [1]
- (b) $\Delta E = hc/\lambda$ (1)
 $9.4 \times 10^{-8} \text{ m}$ (1) [2]
- (c) energy of photon = hf (1)
 $= 21.7 \times 10^{-19} \text{ J}$ (1)
 this is enough energy to promote an electron from the ground state to infinity, thus ionising the atom (1) [3]
- (d) 13.6 eV [1]
- (e) $-13.6 \times 1.6 \times 10^{-19} / 7^2$ (1)
 $0.44 \times 10^{-19} \text{ J}$ (1) [2]
- (f) (i) resultant of (at least) two coherent waves (1)
 destructive interference at nodes (1)
 constructive interference at antinodes (1) [3]
- (ii) $\lambda = \frac{h}{mv}$ (1)
 $mv = \frac{h}{2\pi r}$ (1) [2]
- (iii) $KE = \frac{(mv)^2}{2m} = \frac{h^2}{8\pi^2 mr^2}$ (1)
 $PE = \frac{1}{4\pi\epsilon_0} \frac{e^2}{r}$ (1)
 $E = \frac{h^2}{8\pi^2 mr^2} - \frac{1}{4\pi\epsilon_0} \frac{e^2}{r}$ (0) [2]
- (iv) $\frac{dE}{dr} = 0$ (1)
 $\frac{-h^2}{4\pi^2 mr^3} + \frac{1}{4\pi\epsilon_0} \frac{e^2}{r^2} = 0$ (1)
 $r = \frac{\epsilon_0 h^2}{\pi m e^2}$ (1)
 $= \frac{8.85 \times 10^{-12} \times (6.63 \times 10^{-34})^2}{\pi \times 9.1 \times 10^{31} \times (1.6 \times 10^{-19})^2}$ (1)
 $= 5.3 \times 10^{-11} \text{ m}$ (0) [4]

[Total: 20]

- 10 (a)** $F = mg$ or $75 \text{ kg} \times 9.81 \text{ N kg}^{-1}$ or 734 N (1)
 $k = 734 \text{ N} / 2 \times 10^{-2} \text{ m}$ (1)
 $36.8 \times 10^3 \text{ N m}^{-1}$ (0) [2]
- (b)** $F = -kx$ (minus sign required) (1)
 $F = ma$ (1)
 $a = -(k/m) x$ (0) [2]
- (c)** $\omega = 2\pi f$ and $\omega^2 = k/m$ (1)
 $f = \frac{1}{2\pi} \sqrt{\left(\frac{k}{m}\right)}$ (1) [2]
- (d)** $v = dx/dt = -A\omega \sin \omega t$ (1)
 $a = dv/dt = -A\omega^2 \cos \omega t$ (1)
 $a = -\omega^2 x$ (0) [2]
- (e) (i)** $\omega = 16 \text{ rad s}^{-1}$ (1) [1]
- (ii)** $x = A \cos \omega t$ (1)
 $8.1 \times 10^{-3} \text{ m}$ (1) [2]
- (f) (i)** $a_{\text{max}} = \omega^2 A$ (1)
 2.67 m s^{-2} (1) [2]
- (ii)** $v_{\text{max}} = \omega A$ (1)
 0.16 m s^{-1} (1) [2]
- (iii)** $E_{\text{max}} = \frac{1}{2} m v_{\text{max}}^2$ (1)
 2.0 J (1) [2]
- (g)** resonance occurs when the frequency of road bumps equals the natural frequency (1)
 $f = 2.59 \text{ Hz}$ or $T = 0.38 \text{ s}$ (1)
 15.6 m s^{-1} (1) [3]

[Total: 20]

- 11 (a)** first law:
 energy is conserved (1)
 more sophisticated statement in terms of internal energy, work and heat,
 e.g. $\Delta U = W + Q$ (with U , W and Q defined) (1)
 second law:
 entropy increases (1)
 more sophisticated statement such as the entropy of the universe (or a closed system) never
 decreases **or** the conversion of heat to work with 100% efficiency is impossible (1) [4]
- (b) (i)** living creatures appear to increase in order – with an example (1)
 this would be a reduction of entropy (1) [2]
- (ii)** living things are not closed systems (1)
 when all interactions with the environment are considered, living things increase the
 entropy of the universe (1)
- OR**
- the processes that sustain life are inefficient and dump heat into the environment (1)
 resulting in a net increase of entropy (1) [2]
- (c)** particles in ink and water have thermal energy (1)
 individual particle motions are random (1)
 brownian motion and collisions result in mixing (1)
 there is a large number of possible particle arrangements (micro-states) (1)
 drop + clear water has low probability because it is only realised in a small proportion of the
 arrangements (micro-states) (1)
 the majority of arrangements of particles (micro-states) correspond to approximately uniform
 mixing (inky water) (1)
 the mixed states are more probable than the unmixed states (2)
 random mixing results in evolution to more probable states (1)
 this is irreversible because the mixed state has much more entropy (1)
 the unmixed state has high entropy (1)
 the ink plus water forms an (approximately) closed system (1)
 MAXIMUM 6
 points organised into a complete and coherent argument (1)
 use of technical language (1) [8]
- (d)** the future is distinguished from the past because it has higher entropy or argument in terms
 of a transition from order to disorder (1)
 recognises need (explicitly or implicitly) for an irreversible change to distinguish past from
 future (1)
- valid example of another physical arrow of time, e.g. cosmological arrow of time **or** collapse
 of wavefunction in quantum theory (1)
 explanation of physical arrow of time, e.g. (cosmological) expansion makes future universe
 larger than past universe or (collapse of wavefunction) future is not predictable from the past
 (1)
OR
 reversible laws cannot distinguish the future from the past (1)
 example of reversible laws e.g. Newtonian mechanics or electromagnetism (1) [4]

[Total: 20]

- 12 (a)** absolute time:
time passes at the same rate for all observers (1)
regardless of where they are or how they are moving (1)
absolute space:
distances are the same for all observers (1)
regardless of where they or how they are moving (1) [4]
- (b) (i)** at A: relative velocity = $c + v$ (1)
at B: relative velocity = $c - v$ (1) [2]
- (ii)** laws of Physics are the same for all uniformly moving observers (1)
speed of light is constant **or** relative velocity at A **and** B is c (1) [2]
- (c)** time for a mu-meson to reach surface = $6.0 \times 10^4 / 3.0 \times 10^8$ (1)
= $200 \mu\text{s}$ (1)
this is 100 half-lives in the laboratory frame (1)
ratio would be $R_S/R_{60} = 0.5^{100}$ (1)
 $\approx 8 \times 10^{-31}$ (accept 0) using absolute time (1)
expect very few mu-mesons to reach the surface (1)
- mu-mesons affected by time dilation (1)
mu-meson time 'slows down' so fewer half-lives pass (1)
time dilation factor = $\frac{1}{\sqrt{1 - \frac{v^2}{c^2}}}$ (1)
- = 32 (1)
time passed in mu-meson reference frame is $6.25 \mu\text{s}$ (1)
time passed in mu-meson frame is about 3 half-lives (1)
so about 1/8 mu-mesons reach surface (11%) (1)
MAXIMUM 12 [12]
- [Total: 20]**
- 13 (a)** there is a path difference for light waves reaching P from X or Y (1)
waves arrive 180° out of phase at P (1)
destructive interference occurs (1)
more detail (e.g. $PY - PX = \text{odd no. of half wavelengths}$) (1) [4]
- (b)** a wave (or wave function) moves through the apparatus (1)
wave amplitude is related to probability of photon arrival (1)
wavefunction 'collapses' when an observation is made (1)
probability proportional to amplitude-squared (or intensity) (1)
intensity pattern predicts photon distribution (1)
MAXIMUM 4 [4]
- (c)** photons do not follow well-defined paths (1)
there is an unavoidable uncertainty about the location of each photon (1)
the wavefunction predicts the probabilities (1)
quantum theory is not deterministic (1)
MAXIMUM 2 [2]

(d) zero [1]

(e) the probability increases (1)
 probability now proportional to A^2 (1)
 covering X leaves only one path to the detector so there is no interference (1)
 different experiment (single slit pattern, not double slit) (1)
 MAXIMUM 3 [3]

(f) example from Newtonian mechanics e.g. rolling a dice (1)
 explanation of determinism e.g. If the initial conditions are known precisely then the final state can be predicted by applying the laws of mechanics (1)
 example from quantum theory e.g. radioactive decay or double slit experiment (1)
 explanation of indeterminism e.g. even if we know the state of a nucleus we cannot predict when it will decay, only the probability (of decay per unit time) (1)

additional points e.g.

impossible to know exact initial conditions so even a deterministic theory has uncertainty (1)
 Heisenberg uncertainty principle related to impossibility of knowing exact initial conditions (1)
 quantum theory can predict possible futures but cannot tell us which is the actual future (1)
 macroscopic objects approximate very well to Newtonian Physics so it is possible to make very accurate predictions about the future (1)
 to make accurate predictions we need a reliable theory AND precise initial conditions (1)
 predictions about the future are necessarily statistical (1)
 MAXIMUM 2 [6]

[Total: 20]

University of Cambridge International Examinations
1 Hills Road, Cambridge, CB1 2EU, United Kingdom
Tel: +44 1223 553554 Fax: +44 1223 553558
Email: international@cie.org.uk Website: www.cie.org.uk

© University of Cambridge International Examinations 2007