



Cambridge International Examinations
Cambridge Pre-U Certificate

PHYSICS (PRINCIPAL)

9792/01

Paper 1 Multiple Choice

For Examination from 2016

SPECIMEN PAPER

1 hour 30 minutes

Additional Materials: Multiple Choice Answer Sheet
Soft clean eraser
Soft pencil (type B or HB is recommended)



READ THESE INSTRUCTIONS FIRST

Write in soft pencil.

Do not use staples, paper clips, glue or correction fluid.

Write your name, Centre number and candidate number on the Answer Sheet in the spaces provided unless this has been done for you.

DO NOT WRITE IN ANY BARCODES.

There are **forty** questions on this paper. Answer **all** questions. For each question there are four possible answers **A, B, C** and **D**.

Choose the one you consider correct and record your choice in **soft pencil** on the separate Answer Sheet.

Read the instructions on the Answer Sheet very carefully.

Each correct answer will score one mark. A mark will not be deducted for a wrong answer.

Any working should be done in this booklet.

Electronic calculators may be used.

The syllabus is approved for use in England, Wales and Northern Ireland as a Cambridge International Level 3 Pre-U Certificate.

This document consists of **29** printed pages and **1** blank page.

Data

gravitational field strength close to Earth's surface	$g = 9.81 \text{ N kg}^{-1}$
elementary charge	$e = 1.60 \times 10^{-19} \text{ C}$
speed of light in vacuum	$c = 3.00 \times 10^8 \text{ m s}^{-1}$
Planck constant	$h = 6.63 \times 10^{-34} \text{ J s}$
permittivity of free space	$\epsilon_0 = 8.85 \times 10^{-12} \text{ F m}^{-1}$
gravitational constant	$G = 6.67 \times 10^{-11} \text{ N m}^2 \text{ kg}^{-2}$
electron mass	$m_e = 9.11 \times 10^{-31} \text{ kg}$
proton mass	$m_p = 1.67 \times 10^{-27} \text{ kg}$
unified atomic mass constant	$u = 1.66 \times 10^{-27} \text{ kg}$
molar gas constant	$R = 8.31 \text{ J K}^{-1} \text{ mol}^{-1}$
Avogadro constant	$N_A = 6.02 \times 10^{23} \text{ mol}^{-1}$
Boltzmann constant	$k = 1.38 \times 10^{-23} \text{ J K}^{-1}$
Stefan-Boltzmann constant	$\sigma = 5.67 \times 10^{-8} \text{ W m}^{-2} \text{ K}^{-4}$

Formulae

uniformly accelerated motion	$s = ut + \frac{1}{2}at^2$	change of state	$\Delta E = mL$	
	$v^2 = u^2 + 2as$		refraction	$n = \frac{\sin\theta_1}{\sin\theta_2}$
	$s = \left(\frac{u+v}{2}\right)t$			$n = \frac{v_1}{v_2}$
heating	$\Delta E = mc\Delta\theta$			

diffraction		electromagnetic induction	$E = -\frac{d(N\Phi)}{dt}$
single slit, minima	$n\lambda = b\sin\theta$	Hall effect	$V = Bvd$
grating, maxima	$n\lambda = d\sin\theta$	time dilation	$t' = \frac{t}{\sqrt{1-\frac{v^2}{c^2}}}$
double slit interference	$\lambda = \frac{ax}{D}$	length contraction	$l' = l\sqrt{1-\frac{v^2}{c^2}}$
Rayleigh criterion	$\theta \approx \frac{\lambda}{b}$	kinetic theory	$\frac{1}{2}m\langle c^2 \rangle = \frac{3}{2}kT$
photon energy	$E = hf$	work done on/by a gas	$W = p\Delta V$
de Broglie wavelength	$\lambda = \frac{h}{p}$	radioactive decay	$\frac{dN}{dt} = -\lambda N$
simple harmonic motion	$x = A \cos \omega t$		$N = N_0 e^{-\lambda t}$
	$v = -A\omega \sin \omega t$		$t_{\frac{1}{2}} = \frac{\ln 2}{\lambda}$
	$a = -A\omega^2 \cos \omega t$	attenuation losses	$I = I_0 e^{-\mu x}$
	$F = -m\omega^2 x$	mass-energy equivalence	$\Delta E = c^2 \Delta m$
	$E = \frac{1}{2}mA^2\omega^2$	hydrogen energy levels	$E_n = \frac{-13.6 \text{ eV}}{n^2}$
energy stored in a capacitor	$W = \frac{1}{2}QV$	Heisenberg uncertainty principle	$\Delta p \Delta x \geq \frac{h}{2\pi}$
capacitor discharge	$Q = Q_0 e^{-\frac{t}{RC}}$	Wien's displacement law	$\lambda_{\max} \propto \frac{1}{T}$
electric force	$F = \frac{Q_1 Q_2}{4\pi\epsilon_0 r^2}$	Stefan's law	$L = 4\pi\sigma r^2 T^4$
electrostatic potential energy	$W = \frac{Q_1 Q_2}{4\pi\epsilon_0 r}$	electromagnetic radiation from a moving source	$\frac{\Delta\lambda}{\lambda} \approx \frac{\Delta f}{f} \approx \frac{v}{c}$
gravitational force	$F = -\frac{Gm_1 m_2}{r^2}$		
gravitational potential energy	$E = -\frac{Gm_1 m_2}{r}$		
magnetic force	$F = BIl \sin\theta$		
	$F = BQv \sin\theta$		

- 1 A space probe is leaving a large asteroid. During the initial part of its journey, the weight of the probe in the asteroid's gravitational field does not change.

Which diagram shows the gravitational field line pattern close to the surface of the asteroid?

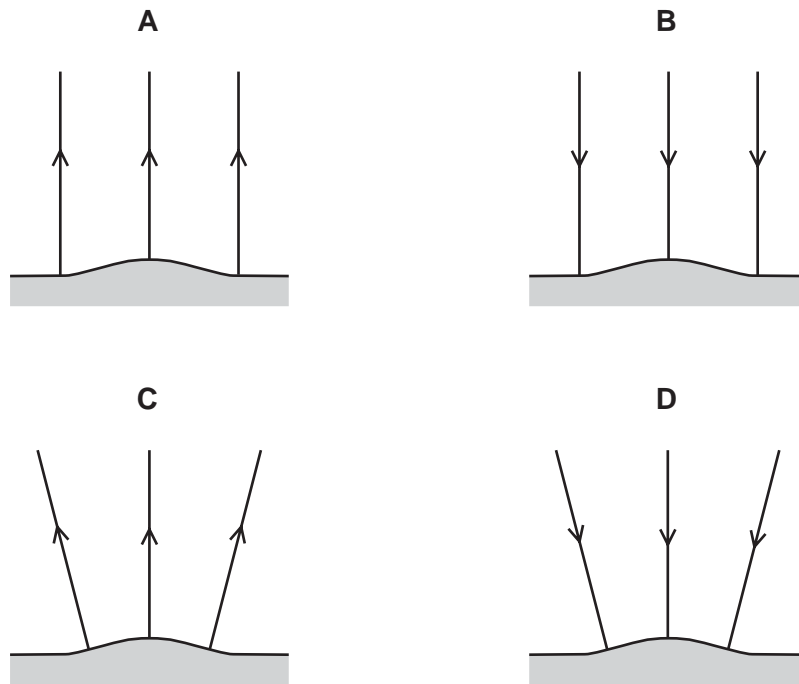

Space for working

- 2 Two masses are connected by a weightless cord, which passes over a frictionless pulley. The masses are held stationary and then released.

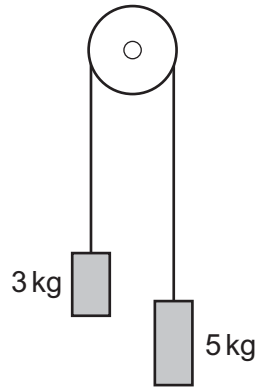

The acceleration due to gravity is g .

What is the magnitude of the acceleration of the masses?

- A $\frac{g}{4}$ B $\frac{3g}{8}$ C $\frac{5g}{8}$ D g
- 3 A water cannon directs a jet of water towards a vertical wall. Each minute, 300 kg of water hits the wall. The water hits the wall horizontally with a velocity 20 m s^{-1} . Assume the water falls vertically after hitting the wall.

What force does the water exert on the wall?

- A 100 N B 200 N C 3000 N D 6000 N

Space for working

- 4 A force F is applied to a door at an angle θ , at a distance d from the hinge.

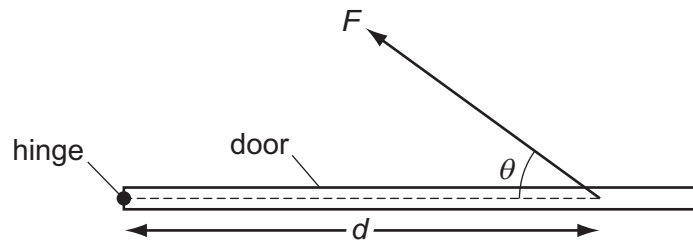

What is the moment of F about the hinge?

- A $Fd\sin\theta$ B $\frac{Fd}{\sin\theta}$ C $Fd\cos\theta$ D $\frac{Fd}{\cos\theta}$
- 5 A rock climber descends a cliff face by abseiling.

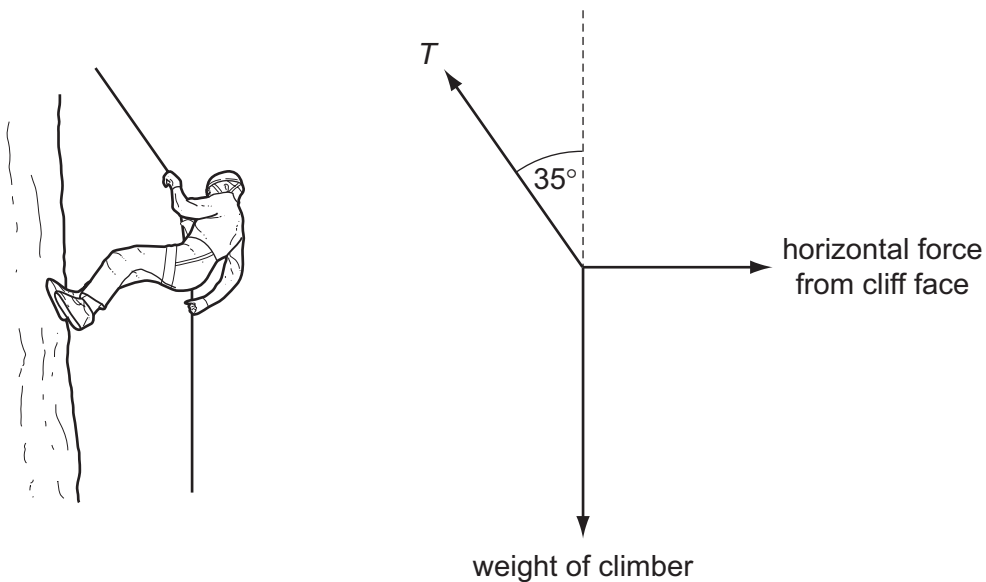

The mass of the climber is 64 kg.

The climber stops descending and holds the rope under tension at an angle of 35° to the vertical.

What is the magnitude of the horizontal force exerted on the climber from the cliff face?

- A 300 N B 360 N C 440 N D 510 N

Space for working

- 6 Water is pumped through a car engine in order to keep it at a constant temperature. The pump stops working and the engine transfers energy to the water in the engine block at a rate of 100 kW. The volume of water in the engine block is $6.0 \times 10^{-3} \text{ m}^3$.

At what rate does the temperature of the water rise?

Water has a specific heat capacity of $4200 \text{ J kg}^{-1} \text{ K}^{-1}$ and a density of 1000 kg m^{-3} .

- A 0.0040 K s^{-1} B 0.25 K s^{-1} C 4.0 K s^{-1} D 24 K s^{-1}

- 7 Before the invention of the modern refrigerator, ice was manufactured industrially and delivered to households. One method used the evaporation of ammonia.

Energy was required to make the ammonia evaporate and 75% of this energy came from liquid water at 0°C , turning the water into ice.

In six hours $8.0 \times 10^4 \text{ kg}$ of ice was produced. At what rate did the ammonia need to be evaporated?

The specific latent heat of fusion of water is 330 kJ kg^{-1} .

The specific latent heat of vaporisation of ammonia is 1370 kJ kg^{-1} .

- A 0.67 kg s^{-1} B 1.2 kg s^{-1} C 12 kg s^{-1} D 20 kg s^{-1}

Space for working

- 8 A force-extension graph for a sample of metal wire is shown.

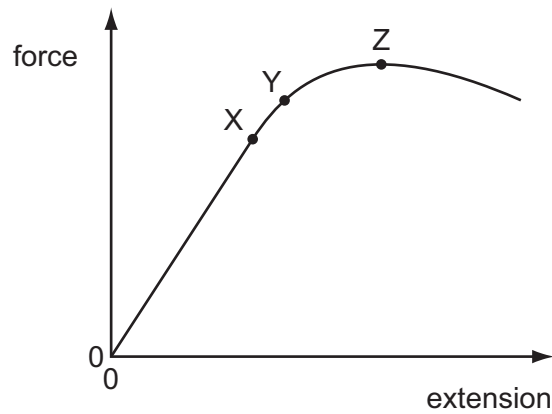

Which row identifies points X, Y and Z?

	point X	point Y	point Z
A	elastic limit	limit of proportionality	breaking stress
B	elastic limit	limit of proportionality	yield point
C	limit of proportionality	elastic limit	breaking stress
D	limit of proportionality	elastic limit	yield point

- 9 A guitarist fits two new strings of the same length and the same material to his guitar. They are tightened to the same tension. Neither string is stretched beyond its limit of proportionality.

One string has four times the radius of the other.

What is the ratio $\frac{\text{stress in the thicker string}}{\text{stress in the thinner string}}$?

- A** 0.0625 **B** 0.25 **C** 4 **D** 16

Space for working

10 An apple is released from rest and falls freely under gravity.

Which graph shows how the kinetic energy (k.e.) of the apple varies with its gravitational potential energy (g.p.e.)? Ignore air resistance.

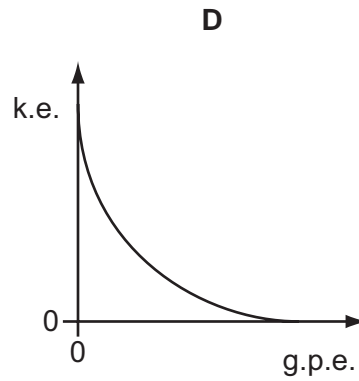
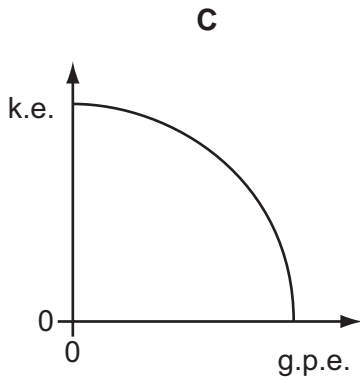
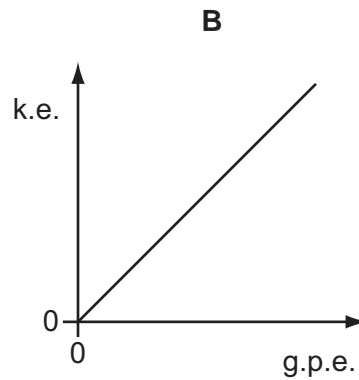
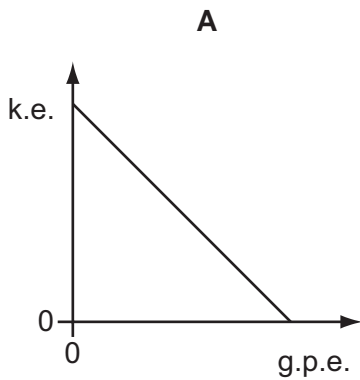

Space for working

- 11 A metal wire of length L and uniform cross-sectional area A has a resistance of $80.0\ \Omega$. The wire is stretched and L increases by 0.5% . The volume of the wire remains constant.

What is the resistance of the stretched wire?

- A $76.0\ \Omega$ B $80.4\ \Omega$ C $80.8\ \Omega$ D $84.0\ \Omega$

- 12 Four identical resistors are connected in a circuit as shown.

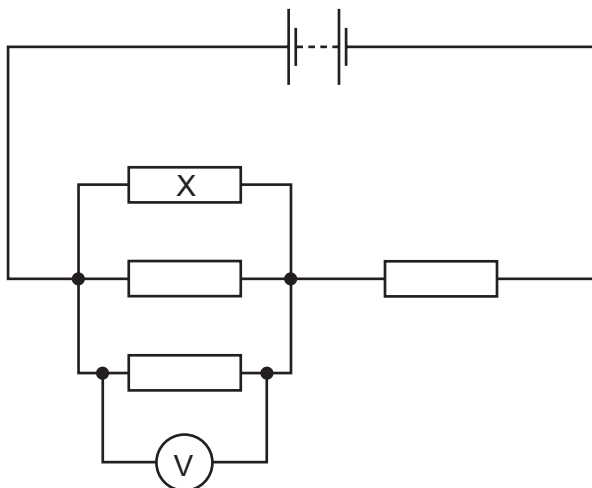

The voltmeter reads $6.0\ \text{V}$. The battery has negligible internal resistance.

What is the potential difference across resistor X and the emf of the battery?

	potential difference across X /V	emf of battery /V
A	2.0	6.0
B	6.0	6.0
C	6.0	12.0
D	6.0	24.0

Space for working

- 13 The diagram shows how the potential difference (p.d.) across a battery varies with the current that it supplies.

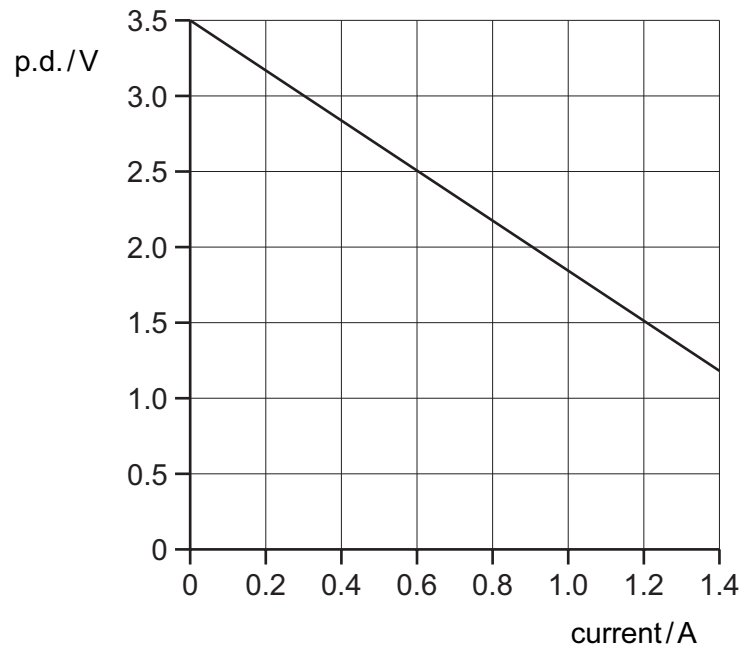

What is the internal resistance of the battery?

- A** 0.60Ω **B** 1.2Ω **C** 1.7Ω **D** 2.3Ω

Space for working

- 14 Two resistors, each of resistance $100\text{ k}\Omega$, are connected in series with a 6.0 V battery of negligible internal resistance.

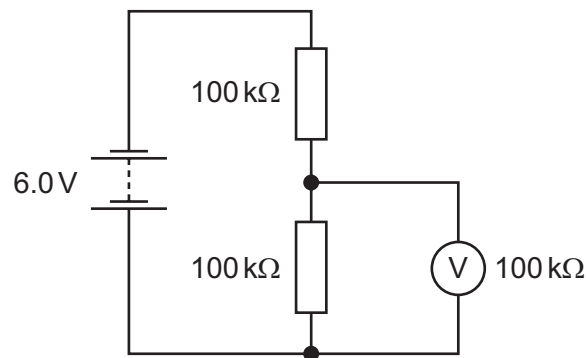

A voltmeter of resistance $100\text{ k}\Omega$ is connected across one of the resistors.

What is the reading on the voltmeter?

- A** 0 V **B** 2.0 V **C** 3.0 V **D** 4.0 V

Space for working

15 A wave has a frequency of 5 Hz. It travels through a medium at a speed of 8 km s^{-1} .

What is the phase difference, in radians, between two points 2 km apart?

- A 0 B $\frac{\pi}{4}$ C $\frac{\pi}{2}$ D π

16 Two radio telescopes separated by a distance d detect parallel waves of wavelength λ from the same distant radio source.

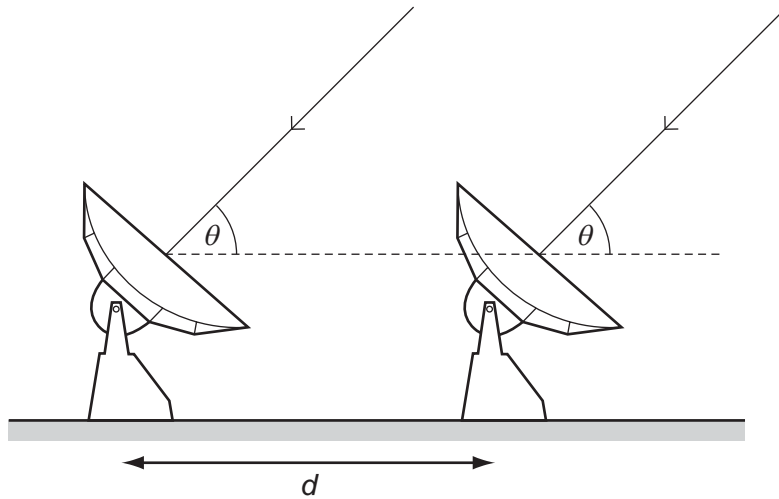

What is the correct expression for the path difference between the waves received at the telescopes?

- A $d \sin \theta$ B $d \cos \theta$ C $\frac{d \sin \theta}{\lambda}$ D $\frac{d \cos \theta}{\lambda}$

Space for working

- 17 Two sources of radio waves are at a distance of 1.0×10^{15} m from Earth. The sources are separated by 1.0×10^{12} m and emit radio waves of wavelength 0.030 m.

What is the estimate for the diameter of a dish of a radio telescope on Earth that will just resolve the two sources?

- A 3.0×10^{-5} m
B 0.03 m
C 30 m
D 3.0×10^{-4} m
- 18 A strip of wet cardboard is fixed on the bottom of a microwave oven. The microwave oven is turned on for a short time. When the card is removed a pattern of dry spots is observed on the cardboard. This is because a standing wave is set up inside the oven.

The dry spots are measured and found to occur at 14 mm, 84 mm, 152 mm, 221 mm and 292 mm from the end of the strip.

From this information, what is the frequency of the microwaves?

- A 2.2 GHz B 2.6 GHz C 4.3 GHz D 5.1 GHz

Space for working

19 The diagram shows a ray of light passing from air into a glass block.

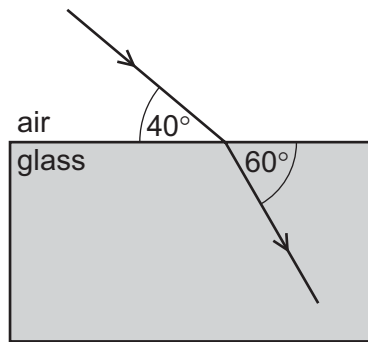

The angle between the ray and the edge of the glass block is 40° in the air and 60° in the glass.

What is the speed of light in the glass block?

- A $1.80 \times 10^8 \text{ m s}^{-1}$
- B $1.89 \times 10^8 \text{ m s}^{-1}$
- C $1.96 \times 10^8 \text{ m s}^{-1}$
- D $2.16 \times 10^8 \text{ m s}^{-1}$

Space for working

20 The graph represents two sound waves, X and Y.

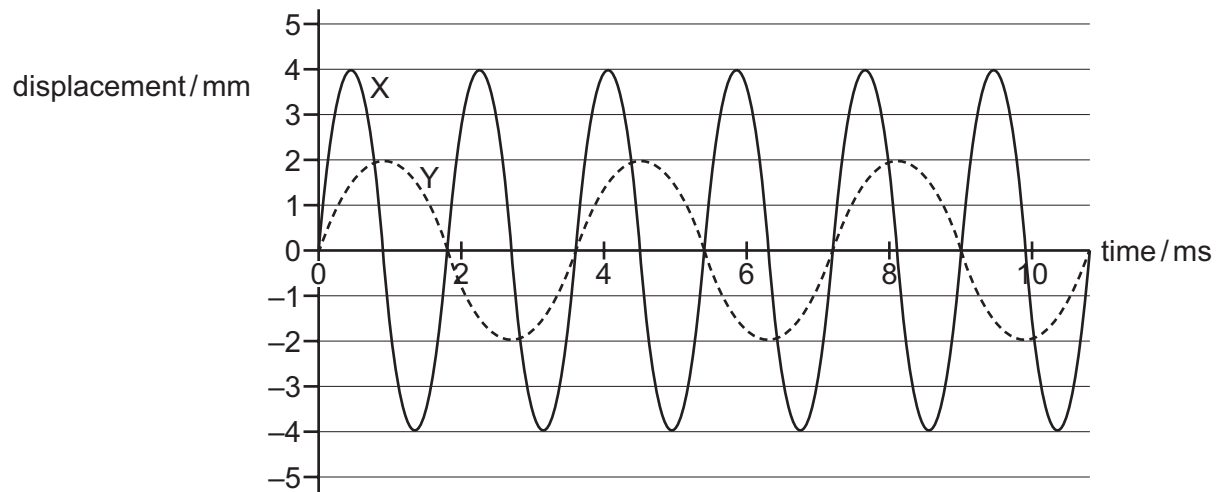

Which row shows the intensity and frequency ratios for X and Y?

	$\frac{\text{intensity of X}}{\text{intensity of Y}}$	$\frac{\text{frequency of X}}{\text{frequency of Y}}$
A	2	$\frac{1}{2}$
B	2	2
C	4	$\frac{1}{2}$
D	4	2

Space for working

- 21 A laser used as a screen pointer emits light of wavelength λ . It emits n photons per second.

What is the power of the laser?

A $\frac{n\lambda}{hc}$

B $\frac{hc}{n\lambda}$

C $\frac{\lambda}{nhc}$

D $\frac{nhc}{\lambda}$

- 22 In an experiment to learn more about the structure of the atom, Geiger and Marsden fired α -particles at a thin sheet of gold foil. They found that most of the α -particles passed through the gold foil with no significant deviation, although a very tiny minority were deflected through large angles, and some were even back-scattered (deflected by more than 90°).

The experiment is repeated with a foil made from a heavier isotope of gold.

How would the results be different?

- A A much greater proportion of the α -particles would be back-scattered.
B A much greater proportion of the α -particles would be deflected through a large angle.
C A greater proportion of the α -particles would pass through with no significant deviation.
D There would be no significant change.

- 23 A nucleus of radium-226, ${}^{226}_{88}\text{Ra}$, decays by emitting an α -particle.

What is a product of this decay?

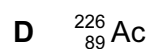
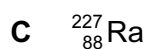
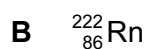
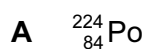

Space for working

24 The diagram shows the turbine of a wind generator.



The tip of one blade moves in a circle of diameter 64.0 m.

The rotor blades make 300 revolutions per hour.

What is the centripetal acceleration of the tip of the rotor blades?

- A 0.26 ms^{-2}
- B 4.39 ms^{-2}
- C 17.5 ms^{-2}
- D $1.58 \times 10^4 \text{ ms}^{-2}$

Space for working

- 25 A mass is suspended from a vertical spring. The mass is displaced upwards from its equilibrium position and released.

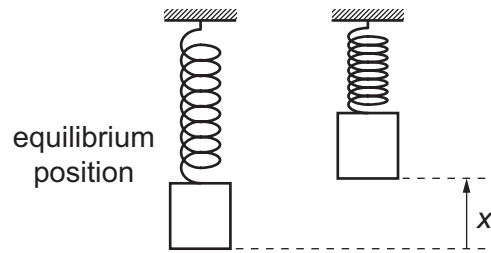

Which pair of graphs shows how the displacement x and the acceleration a of the mass change with time t ?

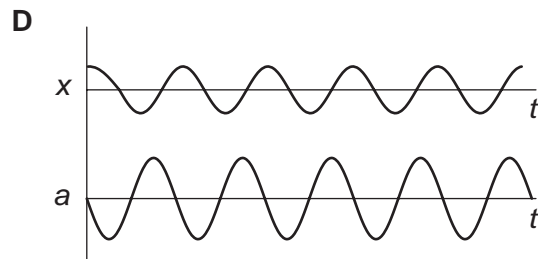
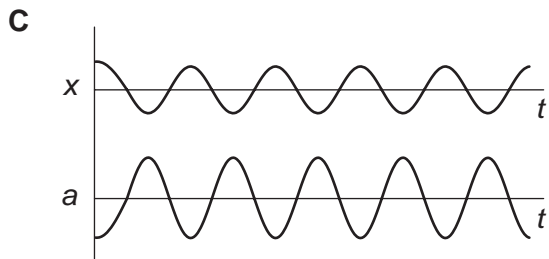
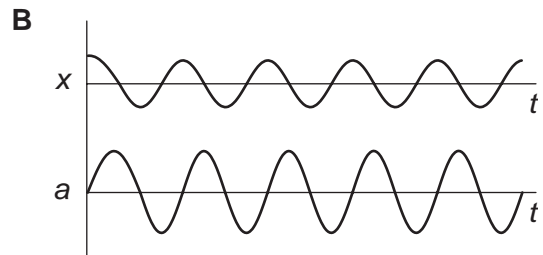
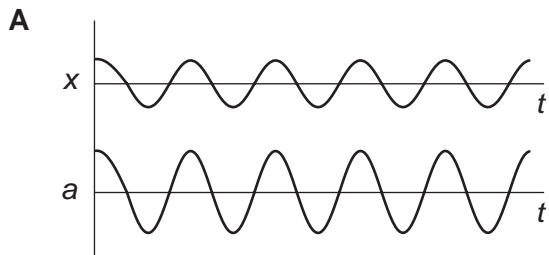

Space for working

26 An object of mass 0.60 kg is held in place by two horizontal springs.

It is displaced sideways and undergoes simple harmonic motion of period 5.0 s.

In each oscillation, it moves from left to right through a total distance of 0.30 m.

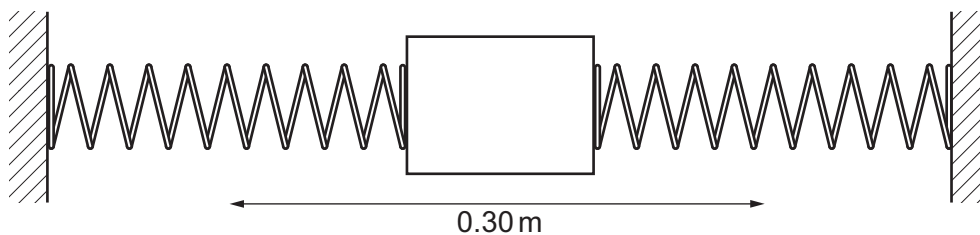

What is the total energy of the simple harmonic motion?

- A $4.3 \times 10^{-3} \text{ J}$
- B $1.1 \times 10^{-2} \text{ J}$
- C $1.7 \times 10^{-2} \text{ J}$
- D $4.3 \times 10^{-2} \text{ J}$

27 In a hydrogen atom, the electron is considered to be a distance of $5.3 \times 10^{-11} \text{ m}$ from the proton.

What is the size of the electrostatic force on the electron at this distance?

- A $5.1 \times 10^{11} \text{ N}$
- B 27 N
- C $8.2 \times 10^{-8} \text{ N}$
- D $2.7 \times 10^{-21} \text{ N}$

Space for working

- 28 A capacitor X of capacitance C is charged by connecting it, with a movable lead, to a battery of emf E .

The lead is moved so that capacitor X is first disconnected from the battery and then connected to a second capacitor Y of capacitance C .

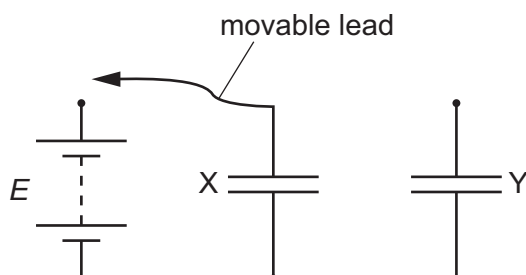

What is the energy stored in capacitor Y?

- A $\frac{1}{8} CE^2$
 B $\frac{1}{4} CE^2$
 C $\frac{1}{2} CE^2$
 D CE^2

Space for working

29 A satellite is in a circular orbit of radius r around the Earth.

The orbital period of the satellite is T .



A second satellite, in a different circular orbit, has an orbital period $64T$.

What is the radius of the orbit of the second satellite?

- A $8r$
- B $16r$
- C $64r$
- D $512r$

Space for working

- 30 A satellite above the Earth in a circular orbit of radius r_1 is moved to a higher circular orbit of radius r_2 . The gravitational force-distance graph is shown for the satellite.

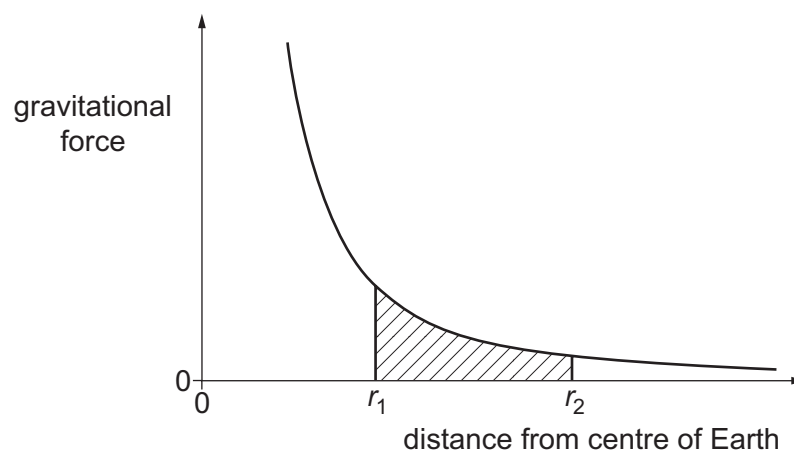

What does the shaded area on the graph represent?

- A the change in gravitational potential energy of the satellite
- B the change in kinetic energy of the satellite
- C the final gravitational potential energy of the satellite
- D the final kinetic energy of the satellite

Space for working

- 31 A horizontal, current-carrying wire is placed in the magnetic field between two opposite magnetic poles. The arrow on the diagram shows the direction of the current in the wire.

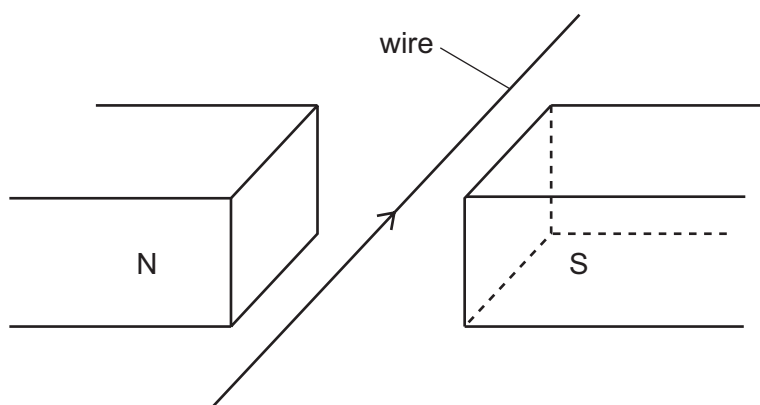

The wire experiences a force.

In which direction does this force act?

- A horizontally to the left
- B horizontally to the right
- C vertically downwards
- D vertically upwards

Space for working

- 32 An electron, travelling in a straight line at $1.46 \times 10^7 \text{ ms}^{-1}$, enters a region where there is a uniform magnetic field.

The diagram shows the path followed by the electron before it enters the magnetic field and within the field.

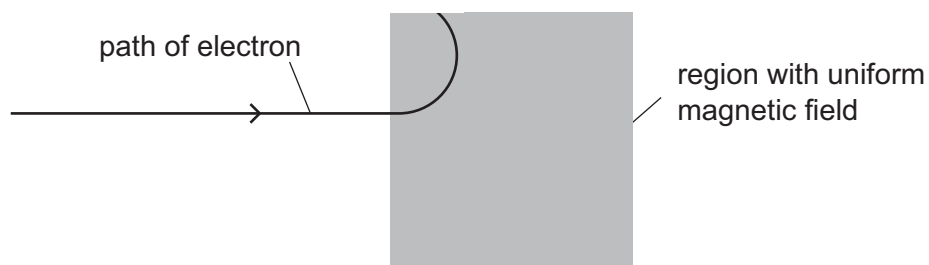

In the magnetic field, the electron follows a semi-circular path of diameter 0.0700 m.

In which direction is the magnetic field and what is the size of the magnetic flux density?

	direction of magnetic field	size of magnetic flux density / T
A	into page	1.19×10^{-3}
B	into page	2.38×10^{-3}
C	out of page	1.19×10^{-3}
D	out of page	2.38×10^{-3}

Space for working

- 33 A sample of oxygen is at a temperature of 57°C . The average mass of an oxygen molecule is $5.36 \times 10^{-26} \text{ kg}$.

What is the root mean square speed of the molecules in this sample?

- A 121 ms^{-1}
- B 210 ms^{-1}
- C 291 ms^{-1}
- D 505 ms^{-1}

- 34 A capacitor discharge circuit of time constant 45 ms includes a capacitor and resistor. The capacitor has a capacitance of $18 \mu\text{F}$

What is the resistance of the resistor?

- A $2.5 \times 10^3 \Omega$
- B 2.5Ω
- C 0.40Ω
- D $4.0 \times 10^{-4} \Omega$

Space for working

- 35 The graph shows the binding energy per nucleon of nuclear particles plotted against their nucleon number.

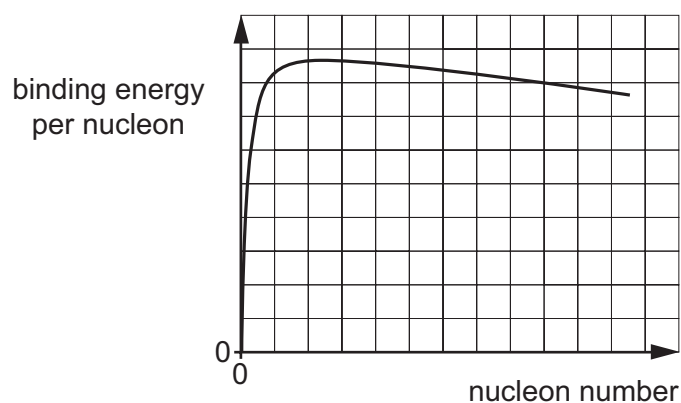

Which statement can be deduced from the shape of the graph?

- A For very high nucleon number particles, fission requires the input of energy.
 - B For very high nucleon number particles, fusion releases energy.
 - C For very high nucleon number particles, fission releases energy.
 - D For very low nucleon number particles, fission releases energy.
- 36 Into which three fundamental families does the standard model classify matter?
- A force carriers, hadrons and leptons
 - B force carriers, hadrons and quarks
 - C force carriers, leptons and quarks
 - D hadrons, leptons and quarks

Space for working

- 37 A line in an atomic line spectrum is caused by an electron falling from a level of energy E_n to a level of energy E_m .

What is the wavelength of the radiation that produces this line?

A $\frac{(E_n - E_m)}{h}$

B $\frac{h}{(E_n - E_m)}$

C $\frac{(E_n - E_m)}{hc}$

D $\frac{hc}{(E_n - E_m)}$

- 38 How much energy, in electron volts, is needed to excite an electron in a hydrogen atom from the lowest energy state (ground state) to the next lowest energy state (first excited state)?

A 3.40 eV

B 4.53 eV

C 10.2 eV

D 13.6 eV

Space for working

39 The electromagnetic radiation emitted by a distant star is detected on Earth.

An astronomer knows the following quantities for the star and the radiation it emits.

F	energy flux density of the radiation measured on Earth
M_S	mass of the star
x	distance of the star from Earth
λ_{\max}	wavelength of the most intense radiation emitted

Which three properties enable the radius of the star to be determined?

- A** F , M_S and x
- B** F , M_S and λ_{\max}
- C** F , x and λ_{\max}
- D** M_S , x and λ_{\max}
- 40 The spectrum of the light produced by a galaxy that is at a distance of 2.72×10^{24} m from Earth is investigated. An absorption line at a wavelength of 601 nm is identified as a sodium line that is found at a wavelength of 589 nm in the spectrum of the Sun.

What is the value of the Hubble constant?

- A** $2.20 \times 10^{-18} \text{ s}^{-1}$
- B** $2.25 \times 10^{-18} \text{ s}^{-1}$
- C** $1.08 \times 10^{-16} \text{ s}^{-1}$
- D** $1.13 \times 10^{-16} \text{ s}^{-1}$

Space for working

BLANK PAGE

Permission to reproduce items where third-party owned material protected by copyright is included has been sought and cleared where possible. Every reasonable effort has been made by the publisher (UCLES) to trace copyright holders, but if any items requiring clearance have unwittingly been included, the publisher will be pleased to make amends at the earliest possible opportunity.

Cambridge International Examinations is part of the Cambridge Assessment Group. Cambridge Assessment is the brand name of University of Cambridge Local Examinations Syndicate (UCLES), which is itself a department of the University of Cambridge.