

PHYSICS

9792/01

Paper 1 Part A Multiple Choice

May/June 2013

1 hour 15 minutes

Additional Materials: Multiple Choice Answer Sheet
 Soft clean eraser
 Soft pencil (type B or HB is recommended)

READ THESE INSTRUCTIONS FIRST

Write in soft pencil.

Do not use staples, paper clips, highlighters, glue or correction fluid.

Write your name, Centre number and candidate number on the Answer Sheet in the spaces provided unless this has been done for you.

There are **forty** questions on this paper. Answer **all** questions. For each question there are four possible answers **A, B, C** and **D**.

Choose the one you consider correct and record your choice in **soft pencil** on the separate Answer Sheet.

Read the instructions on the Answer Sheet very carefully.

Each correct answer will score one mark. A mark will not be deducted for a wrong answer.

Any working should be done in this booklet.

Electronic calculators may be used.

This document consists of **24** printed pages.



Data

gravitational field strength close to Earth's surface	$g = 9.81 \text{ N kg}^{-1}$
elementary charge	$e = 1.60 \times 10^{-19} \text{ C}$
speed of light in vacuum	$c = 3.00 \times 10^8 \text{ m s}^{-1}$
Planck constant	$h = 6.63 \times 10^{-34} \text{ J s}$
permittivity of free space	$\epsilon_0 = 8.85 \times 10^{-12} \text{ F m}^{-1}$
gravitational constant	$G = 6.67 \times 10^{-11} \text{ N m}^2 \text{ kg}^{-2}$
electron mass	$m_e = 9.11 \times 10^{-31} \text{ kg}$
proton mass	$m_p = 1.67 \times 10^{-27} \text{ kg}$
unified atomic mass constant	$u = 1.66 \times 10^{-27} \text{ kg}$
molar gas constant	$R = 8.31 \text{ J K}^{-1} \text{ mol}^{-1}$
Avogadro constant	$N_A = 6.02 \times 10^{23} \text{ mol}^{-1}$
Boltzmann constant	$k = 1.38 \times 10^{-23} \text{ J K}^{-1}$
Stefan-Boltzmann constant	$\sigma = 5.67 \times 10^{-8} \text{ W m}^{-2} \text{ K}^{-4}$

Formulae

uniformly accelerated motion $s = ut + \frac{1}{2} at^2$

$$v^2 = u^2 + 2as$$

$$s = \left(\frac{u+v}{2} \right) t$$

heating $\Delta E = mc\Delta\theta$

change of state $\Delta E = mL$

refraction $n = \frac{\sin\theta_1}{\sin\theta_2}$

$$n = \frac{v_1}{v_2}$$

diffraction

single slit, minima $n\lambda = b \sin \theta$

grating, maxima $n\lambda = d \sin \theta$

double slit interference $\lambda = \frac{ax}{D}$

Rayleigh criterion $\theta \approx \frac{\lambda}{b}$

photon energy $E = hf$

de Broglie wavelength $\lambda = \frac{h}{p}$

simple harmonic motion $x = A \cos \omega t$

$$v = -A\omega \sin \omega t$$

$$a = -A\omega^2 \cos \omega t$$

$$F = -m\omega^2 x$$

$$E = \frac{1}{2} mA^2\omega^2$$

energy stored in a capacitor $W = \frac{1}{2} QV$

electric force $F = \frac{Q_1 Q_2}{4\pi\epsilon_0 r^2}$

electrostatic potential energy $W = \frac{Q_1 Q_2}{4\pi\epsilon_0 r}$

gravitational force $F = -\frac{Gm_1 m_2}{r^2}$

gravitational potential energy $E = -\frac{Gm_1 m_2}{r}$

magnetic force $F = BIL \sin \theta$

$$F = BQv \sin \theta$$

electromagnetic induction $F = -\frac{d(N\Phi)}{dt}$

Hall effect $V = Bvd$

time dilation $t' = \frac{t}{\sqrt{1 - \frac{v^2}{c^2}}}$

kinetic theory $\frac{1}{2} m\langle c^2 \rangle = \frac{3}{2} kT$

work done on/by a gas $W = p\Delta V$

radioactive decay $\frac{dN}{dt} = -\lambda N$

$$N = N_0 e^{-\lambda t}$$

$$t_{\frac{1}{2}} = \frac{\ln 2}{\lambda}$$

attenuation losses $I = I_0 e^{-\mu x}$

mass-energy equivalence $\Delta E = c^2 \Delta m$

hydrogen energy levels $E_n = \frac{-13.6 \text{ eV}}{n^2}$

Heisenberg uncertainty principle $\Delta p \Delta x \geq \frac{h}{2\pi}$

$$\Delta E \Delta t \geq \frac{h}{2\pi}$$

Wien's displacement law $\lambda_{\max} \propto \frac{1}{T}$

Stefan's law $L = 4\pi\sigma r^2 T^4$

electromagnetic radiation from a moving source $\frac{\Delta\lambda}{\lambda} \approx \frac{\Delta f}{f} \approx \frac{v}{c}$

- 1 A force of 30 N is required to pull the strings of a catapult into the firing position.

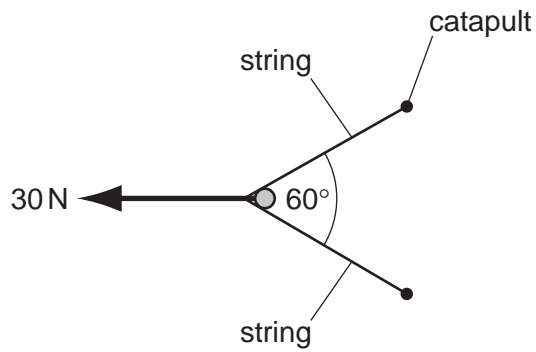

What is the tension in each string?

- A** 15 N **B** 17 N **C** 30 N **D** 35 N
- 2 A wooden block of mass 5 kg is released on a smooth inclined plane.

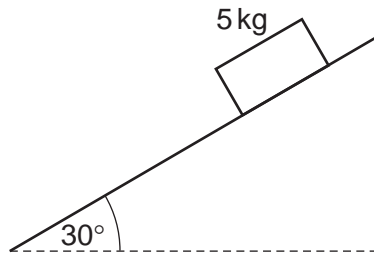

The acceleration due to gravity is given by g .

What is the acceleration of the block down the inclined plane?

- A** $\frac{g}{5}$ **B** $\frac{g}{2}$ **C** $g\sqrt{\frac{3}{2}}$ **D** g

Space for working

- 3 A cylindrical vessel stands upright on its base of cross-sectional area A . It contains a volume V of a liquid with density ρ .

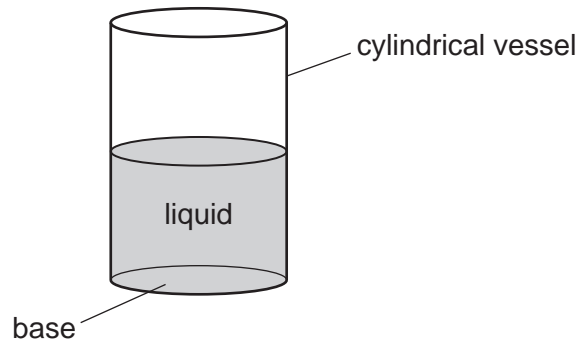

Which combination will produce the same pressure at the bottom of the liquid?

	cross-sectional area	density	volume
A	$\frac{A}{2}$	2ρ	V
B	$\frac{A}{2}$	$\frac{\rho}{2}$	$2V$
C	$2A$	2ρ	V
D	$2A$	$\frac{\rho}{2}$	$2V$

Space for working

- 4 The diagram shows a man standing in a lift.

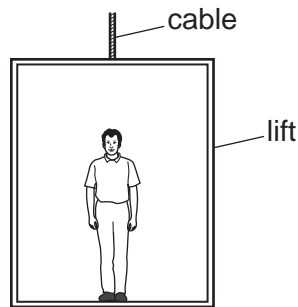

The forces acting on the man and the forces acting on the lift are shown below.

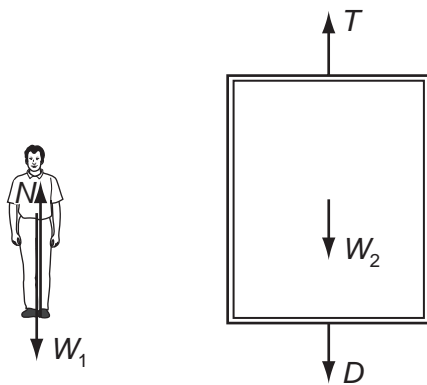

N is the force from the lift floor on the man.
 W_1 is the weight of the man.
 T is the tension in the lift cable.
 W_2 is the weight of the lift.
 D is the force from the man on the lift floor.

Which statement is correct?

- A N and W_1 are always equal and opposite.
- B $(W_1 + W_2)$ is always equal to T .
- C If $N = W_1$ the lift must be at rest.
- D If $T = (D + W_2)$ the lift must have a constant velocity.

Space for working

- 5 A trailer of mass 400 kg is pulled by a car of mass 1200 kg. The diagram shows the horizontal forces acting on the trailer.

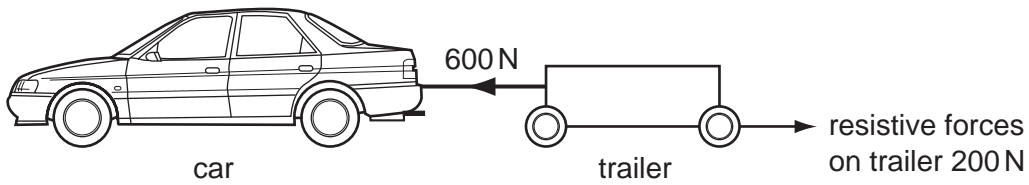

What is the unbalanced force acting on the car?

- A 400 N B 600 N C 1200 N D 1800 N
- 6 A tennis ball of mass 56 g is struck by a tennis racquet. The graph shows how the force exerted on the ball by the racquet varies with time.

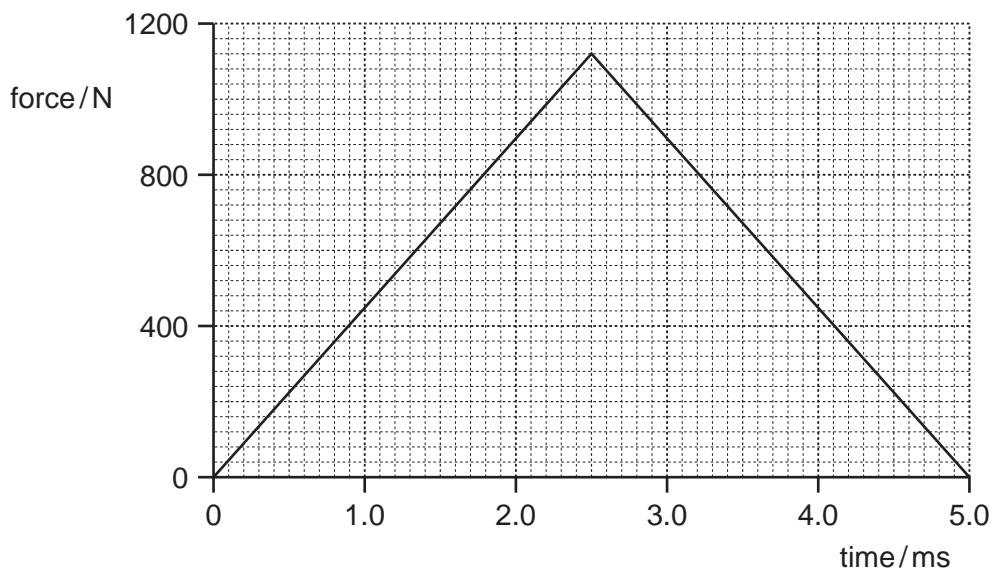

What is the change in the velocity of the tennis ball?

- A 50 cm s^{-1} B 100 cm s^{-1} C 50 m s^{-1} D 100 m s^{-1}

Space for working

- 7 A clay pigeon is launched vertically into the air from the ground.

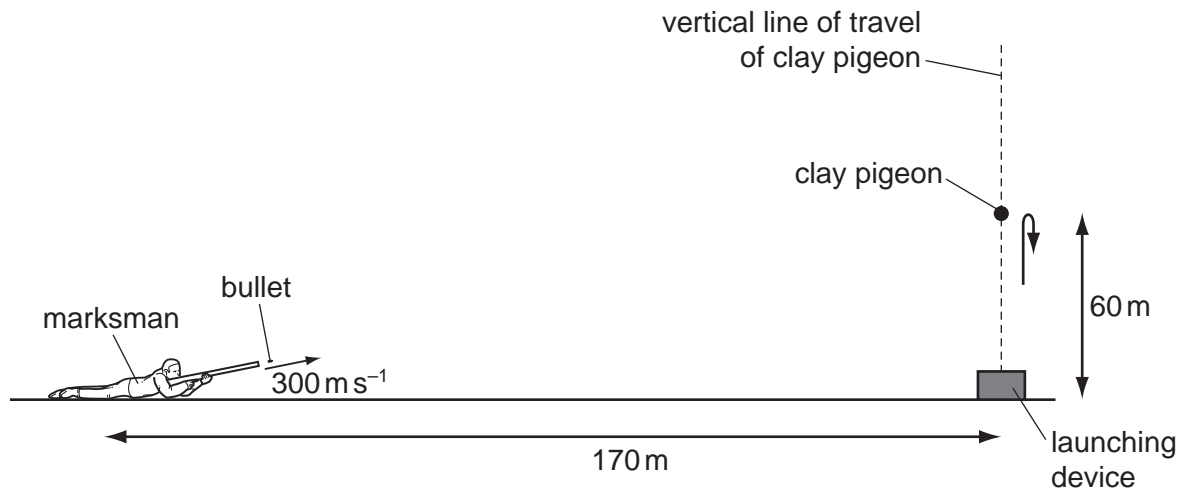

(diagram not to scale)

A marksman lies 170 m away from the launching device on level ground. Just as the clay pigeon reaches its maximum height of 60 m, the marksman fires a bullet aimed directly at the clay pigeon. The bullet leaves the rifle with a speed of 300 m s^{-1} .

At what time after the bullet is fired is the clay pigeon hit? Assume air resistance is negligible.

- A 0.17 s
- B 0.57 s
- C 0.60 s
- D 1.66 s

Space for working

- 8 The diagram shows a uniform beam of length 100 cm pivoted 20 cm from one end and balanced with a 5.0 kg mass.

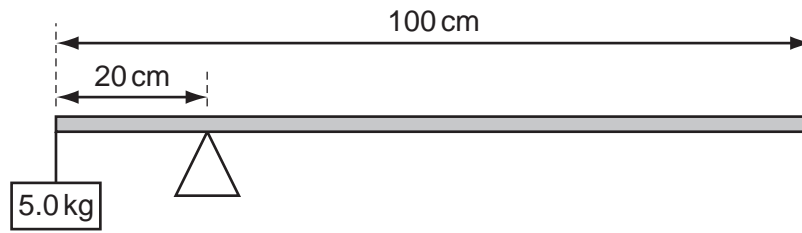

What is the mass of the beam?

- A 1.00 kg B 1.25 kg C 3.3 kg D 5.0 kg
- 9 A car of mass 1000 kg is moving at 25 m s^{-1} . The brakes are applied, causing the car to stop.

The car has four brakes, each consisting of a 3.0 kg metal disc that rubs against a wheel. The specific heat capacity of the metal from which the discs are made is $400 \text{ J kg}^{-1} \text{ K}^{-1}$.

What is the maximum rise in the temperature of the brakes?

- A 2.6°C B 5.2°C C 65°C D 260°C

Space for working

- 10 A block of ice is heated at a constant rate by a 0.25 kW heater.

The graph below shows how the temperature of the ice (and subsequently water) changes with time.

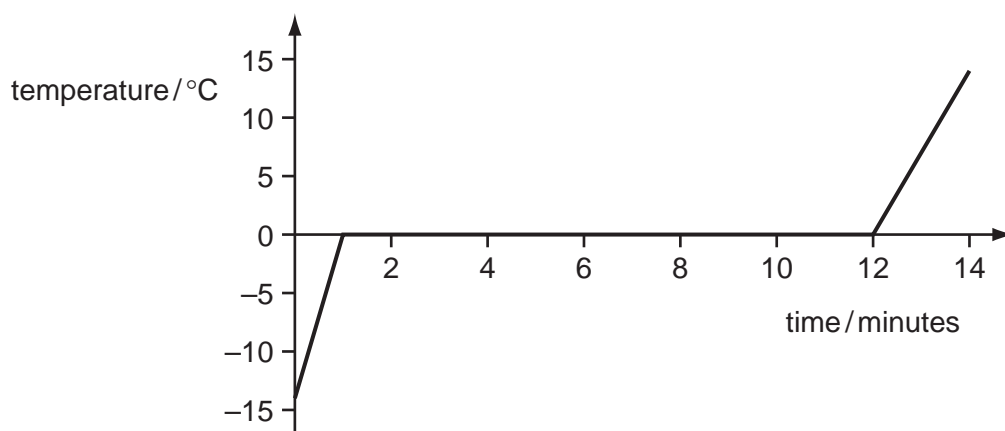

Assume that all the energy supplied is used to heat the ice.

What is the original mass of the block of ice? The specific latent heat of fusion of water is $3.3 \times 10^5 \text{ J kg}^{-1}$.

- A** 0.5g **B** 8.3g **C** 0.5kg **D** 8.3kg
- 11 In order to calculate the energy needed to vaporise a certain quantity of a liquid, it is necessary to know the values of which two quantities?

	quantity 1	quantity 2
A	boiling point	specific heat capacity of liquid
B	boiling point	specific latent heat of liquid
C	mass	specific heat capacity of liquid
D	mass	specific latent heat of liquid

Space for working

- 12 A trolley is pushed with a force of 3.0 N for 2.0 s along a frictionless track.

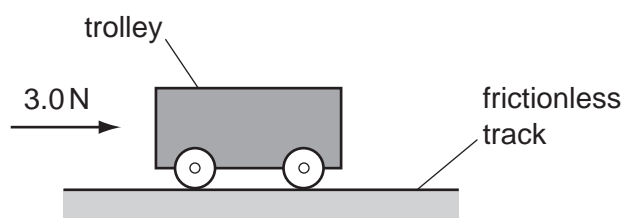

The graph shows the velocity of the trolley against time.

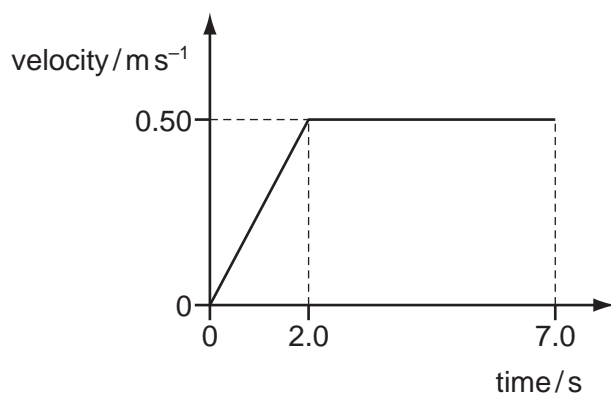

How much work is done by the force on the trolley?

- A** 1.5 J **B** 3.0 J **C** 6.0 J **D** 9.0 J

- 13 Sky City in Tokyo is 1.00 km tall. The lifts take 2.0 minutes to reach the top.

A lift of mass 450 kg carries two passengers who have a combined mass of 140 kg.

What is the average power supplied to the ascending lift?

- A** 4.9 kW **B** 37 kW **C** 48 kW **D** 2900 kW

Space for working

- 14 A toy is released from rest on a smooth curved surface.

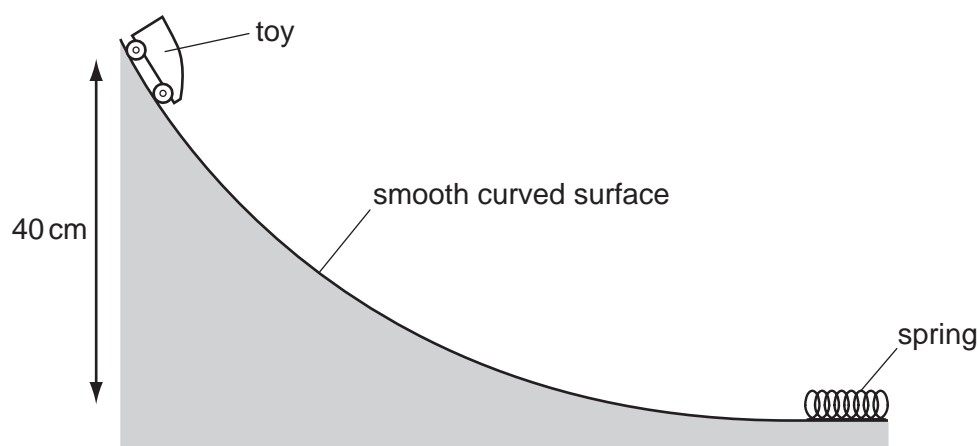

The toy, of mass 0.22 kg , runs down the curved surface through a vertical distance of 0.40 m . It strikes a spring of force constant 350 N m^{-1} and compresses it a distance x before coming to rest.

Assuming no energy losses, what is the value of x ?

- A $4.9 \times 10^{-3}\text{ m}$ B $7.2 \times 10^{-3}\text{ m}$ C $2.2 \times 10^{-2}\text{ m}$ D $7.0 \times 10^{-2}\text{ m}$
- 15 Which force will produce an extension of 1.0 mm in a steel wire of length 4.0 m and diameter 0.50 mm ?
(Young modulus of steel = 200 GPa)
- A 9.8 N B 39 N C 9800 N D 3900 N
- 16 Wire X and wire Y are both made of copper. Wire X has twice the length of wire Y. The wires are hung vertically and stretched by hanging identical weights from the bottom of each.

The extension of wire Y is twice that of wire X.

What is the ratio: $\frac{\text{diameter of wire X}}{\text{diameter of wire Y}}$?

- A $\frac{1}{4}$ B $\frac{1}{2}$ C 2 D 4

Space for working

- 17 A tensile force causes a wire of length L , Young modulus E and cross-sectional area A to be stretched by a length x .

Which expression gives the elastic energy stored in the wire?

- A $\frac{EAL}{2}$ B $\frac{ExA}{L}$ C $\frac{Ex^2A}{L}$ D $\frac{Ex^2A}{2L}$

- 18 The diagram shows a circuit.

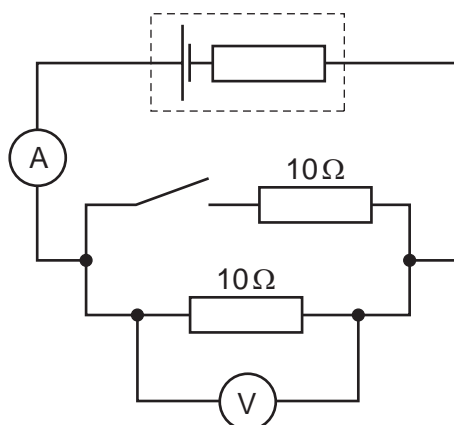

The cell has an e.m.f. of 1.5 V . The voltmeter reads 1.2 V when the switch is open.

What happens to the voltmeter reading and the current through the ammeter when the switch is closed?

	voltmeter reading	current through ammeter
A	decreases	increases
B	increases	decreases
C	stays the same	decreases
D	stays the same	increases

Space for working

19 In the diagrams, resistor P has twice the resistance of resistor Q.

Which network has the lowest resistance?

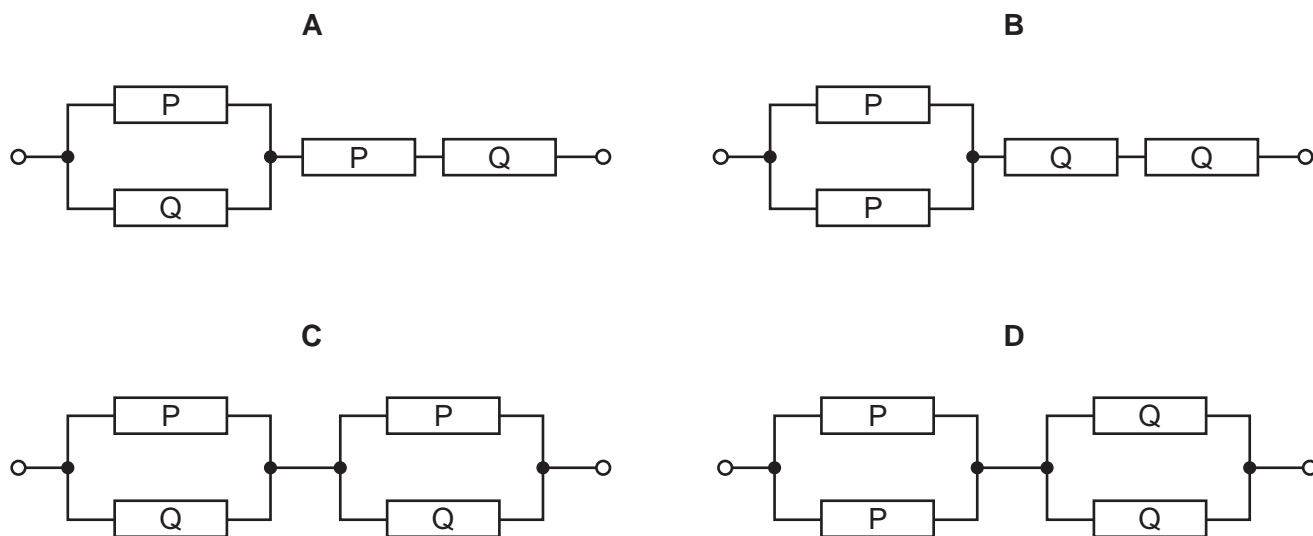

20 A circuit is connected as shown.

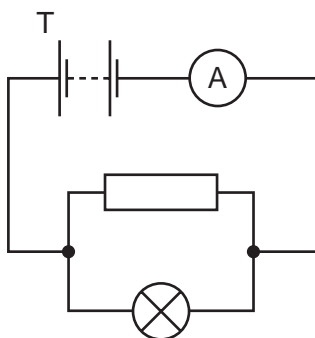

The ammeter reads 2.0 A. The battery has negligible internal resistance.

Which statement about the circuit is correct?

- A** Each second, 2.0 C of charge flows through the lamp.
- B** Each second, 6.25×10^{18} electrons flow through the resistor.
- C** Each second, 1.25×10^{19} electrons flow away from terminal T of the battery.
- D** Each second, fewer than 1.25×10^{19} electrons flow through the lamp.

Space for working

- 21 A potential divider circuit is set up by connecting two resistors in series as shown. The potential difference across the circuit is V .

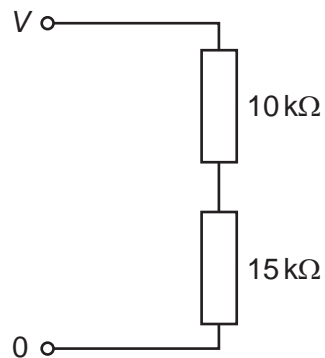

What is the potential difference across the $10\text{ k}\Omega$ resistor?

- A $\frac{10}{25} V$ B $\frac{15}{25} V$ C $\frac{10}{15} V$ D $\frac{15}{10} V$
- 22 Two resistors of resistance R are connected in parallel with a cell of negligible internal resistance. The power delivered by the cell is P .

One of the resistors burns out.

What is the power now delivered by the cell?

- A $\frac{1}{4} P$ B $\frac{1}{2} P$ C $2P$ D $4P$

Space for working

- 23 A wire has a length of 2.2 m and a diameter of 1.6 mm. The current in the wire is 0.44 A when a potential difference of 0.50 V is applied between its ends.

What is the resistivity of the wire?

- A $8.0 \times 10^{-7} \Omega \text{ m}$
B $1.0 \times 10^{-6} \Omega \text{ m}$
C $3.2 \times 10^{-6} \Omega \text{ m}$
D $4.2 \times 10^{-6} \Omega \text{ m}$
- 24 Wire X has radius r , length l and is made of a material whose resistivity is ρ .
Wire Y has radius $3r$, length $3l$ and is made of material whose resistivity is 3ρ .

When X and Y are connected in series, their combined resistance is R_s . When X and Y are connected in parallel, their combined resistance is R_p .

What is the ratio $\frac{R_s}{R_p}$?

- A 1 B 3 C 4 D $\frac{16}{3}$
- 25 When there is a current in a tungsten filament lamp, the filament gets hot and its resistance increases.

The resistance of tungsten is approximately proportional to its absolute temperature ($R \propto T$). The power supplied to the filament is proportional to the fourth power of its absolute temperature ($P \propto T^4$).

Which relationship follows from this?

- A $I^5 V^3$ is a constant.
B $\frac{I^5}{V^3}$ is a constant.
C $\frac{V^5}{I^3}$ is a constant.
D $\frac{V^5}{I^4}$ is a constant.

Space for working

- 26 Which of these parts of the electromagnetic spectrum has both frequency greater than infra-red and wavelength smaller than X-rays?
- A gamma rays
 - B microwaves
 - C radio waves
 - D ultraviolet

- 27 Light passes from air into a glass block as shown.

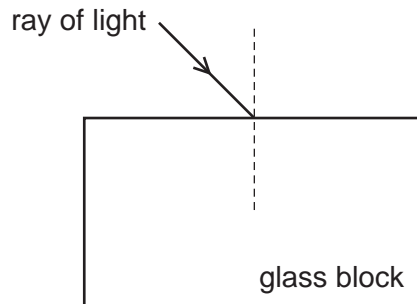

Which features of the light **all** change as the light enters the block?

- A direction of travel, frequency and speed
- B direction of travel, frequency and wavelength
- C direction of travel, speed and wavelength
- D frequency, speed and wavelength

Space for working

28 Microwaves travel more slowly in carbon dioxide than in air.

A beam of microwaves is directed towards a balloon filled with carbon dioxide as shown in the diagram.

At which point will the intensity of microwaves be greatest?

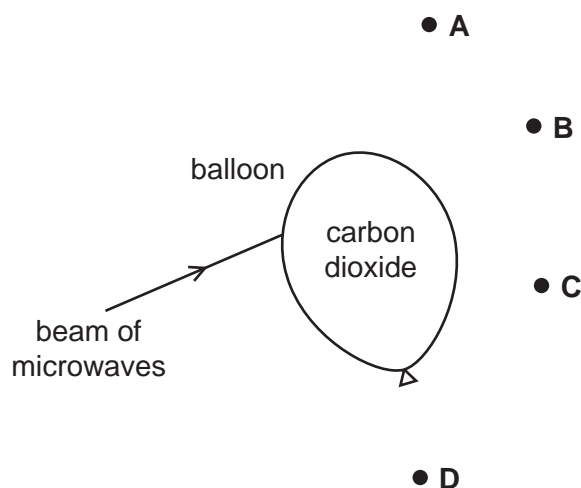

29 Light reflected from the surface of water is partially polarised.

A polaroid filter is used to view a water surface.

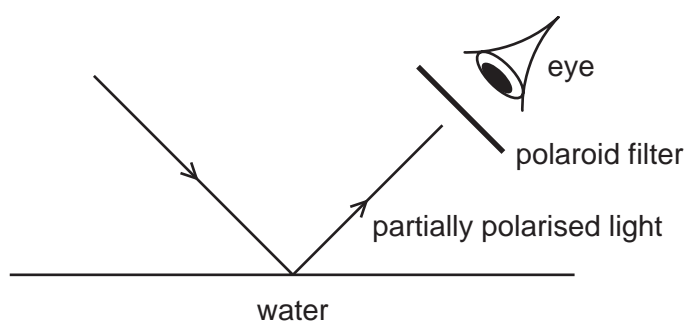

The polaroid filter is rotated through 180° in the plane perpendicular to the reflected light.

Which statement could describe the observations?

- A The brightness changes from a maximum to a minimum.
- B The brightness changes from a minimum to a maximum.
- C The brightness changes from a maximum to a minimum to a maximum.
- D The brightness changes from a minimum to a maximum to a minimum to a maximum.

Space for working

- 30 A microphone is connected to an oscilloscope and picks up sound waves X and Y. The diagram shows the displays on the oscilloscope screen. The same oscilloscope settings are used for both sound waves.

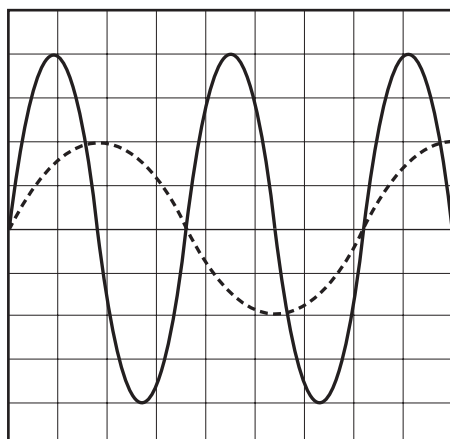

key
 — signal X
 - - - - signal Y

The frequency and intensity of signal X are f_x and I_x .
 The frequency and intensity of signal Y are f_y and I_y .

What are the frequency and intensity ratios?

	$\frac{f_y}{f_x}$	$\frac{I_y}{I_x}$
A	0.5	0.25
B	0.5	0.5
C	2	0.25
D	2	0.5

Space for working

31 Magenta light consisting of a mixture of blue and red light is incident on a diffraction grating.

What is the expected arrangement of first orders about the central zero order?

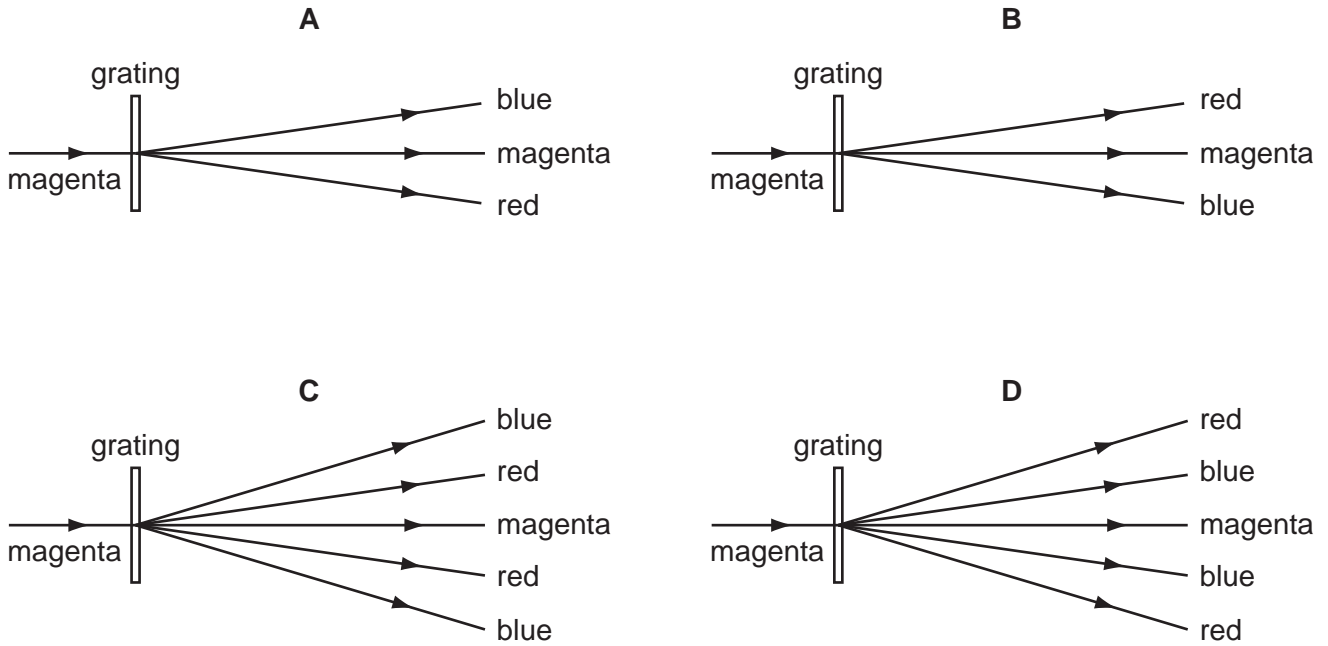

32 Light produced by a calcium discharge lamp strikes a diffraction grating, with 800 slits per mm, at right angles to the surface.

The second order spectrum includes a line at an angle of 41.0° to the normal.

What is the wavelength of the light producing this line?

- A** $1.6 \times 10^{-6} \text{ m}$ **B** $4.1 \times 10^{-7} \text{ m}$ **C** $4.6 \times 10^{-7} \text{ m}$ **D** $8.2 \times 10^{-7} \text{ m}$

Space for working

- 33 A parallel, monochromatic beam of electromagnetic radiation is incident at right angles onto a single slit of width 0.010 mm.

The graph shows how the intensity of the radiation varies with the sine of the angle θ through which the light is diffracted.

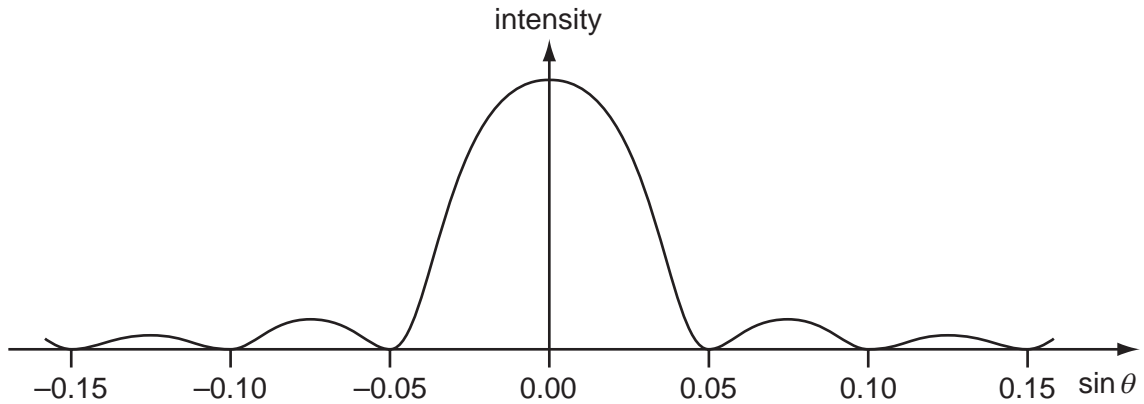

What is the wavelength of the radiation?

- A 500 nm B 750 nm C 500 μm D 750 μm
- 34 A uniform wire XY is fixed at its ends and vibrates transversely in its fundamental mode.

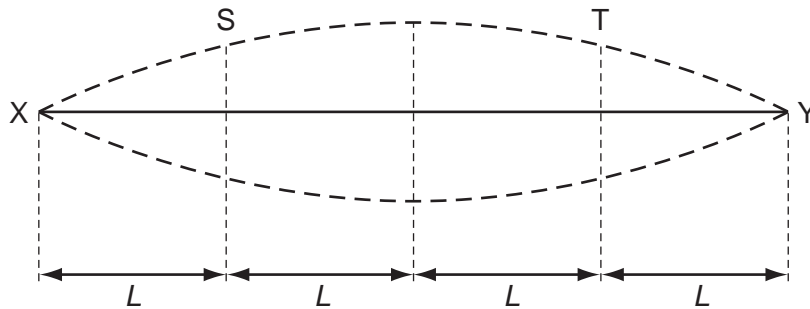

What is the phase difference between the displacement of a particle at S and that of a particle at T?

- A 0° B 45° C 135° D 180°

Space for working

- 35 An electron of mass m and charge e is accelerated from rest through a potential difference of V .

What is the frequency of a photon whose wavelength is equal to the de Broglie wavelength of this electron? (c is the speed of light and h is the Planck constant.)

- A $\frac{c\sqrt{2meV}}{h}$ B $\frac{h}{\sqrt{2meV}}$ C $\frac{hc}{eV}$ D $\frac{eV}{h}$

- 36 The photoelectric work function for sodium is 3.65×10^{-19} J.

Ultraviolet radiation of frequency 8.90×10^{14} Hz is directed at a clean sodium surface in a vacuum causing photoelectric emission.

What is the kinetic energy of the fastest electrons emitted?

- A 2.25×10^{-19} J
 B 3.65×10^{-19} J
 C 5.90×10^{-19} J
 D 9.55×10^{-19} J
- 37 Nuclei of carbon-14 can be produced when neutrons interact with nuclei of nitrogen-14. The reaction equation is shown.

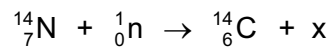

What is particle x?

- A an electron
 B a neutrino
 C a positron
 D a proton

Space for working

- 38 Which row correctly identifies the nuclear radiation with the greatest penetrating power and the nuclear radiation with the greatest ionising power?

	penetrating power	ionising power
A	α	α
B	α	γ
C	γ	α
D	γ	γ

- 39 The diagram represents the thermonuclear fission of a ${}_{92}^{235}\text{U}$ nucleus. The uranium nucleus absorbs a neutron and produces the nuclides X and Y and two neutrons.

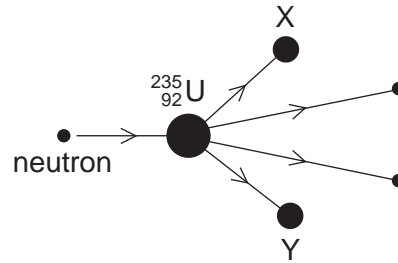

Which row identifies what X and Y might be?

	X	Y
A	${}_{36}^{92}\text{Kr}$	${}_{56}^{141}\text{Ba}$
B	${}_{36}^{92}\text{Kr}$	${}_{56}^{142}\text{Ba}$
C	${}_{36}^{93}\text{Kr}$	${}_{56}^{142}\text{Ba}$
D	${}_{36}^{93}\text{Kr}$	${}_{56}^{143}\text{Ba}$

Space for working

- 40** A sample of a radioactive isotope with nucleon number 210 decays by alpha emission into a stable isotope with nucleon number 206. The process has a half-life of 140 days.

If all the emitted alpha-particles escape from the sample but none of the daughter product escapes, what will be the percentage fall in the mass of the source after 280 days?

- A** 0.48% **B** 1.43% **C** 25% **D** 75%

Space for working

Permission to reproduce items where third-party owned material protected by copyright is included has been sought and cleared where possible. Every reasonable effort has been made by the publisher (UCLES) to trace copyright holders, but if any items requiring clearance have unwittingly been included, the publisher will be pleased to make amends at the earliest possible opportunity.

University of Cambridge International Examinations is part of the Cambridge Assessment Group. Cambridge Assessment is the brand name of University of Cambridge Local Examinations Syndicate (UCLES), which is itself a department of the University of Cambridge.