



UNIVERSITY OF CAMBRIDGE INTERNATIONAL EXAMINATIONS  
 Cambridge International Level 3 Pre-U Certificate  
 Principal Subject

CANDIDATE  
NAME

CENTRE  
NUMBER

--	--	--	--	--

CANDIDATE  
NUMBER

--	--	--	--



**PHYSICS**

**9792/02**

Paper 2 Part A Written Paper

**May/June 2011**

**2 hours**

Candidates answer on the Question Paper.

No Additional Materials are required.

**READ THESE INSTRUCTIONS FIRST**

Write your Centre number, candidate number and name on all the work you hand in.  
 Write in dark blue or black pen.  
 You may use a soft pencil for any diagrams, graphs or rough working.  
 Do not use staples, paper clips, highlighters, glue or correction fluid.  
**DO NOT WRITE IN ANY BARCODES.**

**Section A**

Answer **all** questions.  
 You are advised to spend about 1 hour 30 minutes on this section.

**Section B**

Answer the **one** question.  
 You are advised to spend about 30 minutes on this section.  
 The question is based on the material in the Insert.

You may lose marks if you do not show your working or if you do not use appropriate units.

At the end of the examination, fasten all your work securely together.  
 The number of marks is given in brackets [ ] at the end of each question or part question.

For Examiner's Use	
1	
2	
3	
4	
5	
6	
7	
8	
<b>Total</b>	

This document consists of **20** printed pages, **4** blank pages and **1** insert.



**Data**

gravitational field strength close to Earth's surface	$g = 9.81 \text{ N kg}^{-1}$
elementary charge	$e = 1.60 \times 10^{-19} \text{ C}$
speed of light in vacuum	$c = 3.00 \times 10^8 \text{ m s}^{-1}$
Planck constant	$h = 6.63 \times 10^{-34} \text{ J s}$
permittivity of free space	$\epsilon_0 = 8.85 \times 10^{-12} \text{ F m}^{-1}$
gravitational constant	$G = 6.67 \times 10^{-11} \text{ N m}^2 \text{ kg}^{-2}$
electron mass	$m_e = 9.11 \times 10^{-31} \text{ kg}$
proton mass	$m_p = 1.67 \times 10^{-27} \text{ kg}$
unified atomic mass constant	$u = 1.66 \times 10^{-27} \text{ kg}$
molar gas constant	$R = 8.31 \text{ J K}^{-1} \text{ mol}^{-1}$
Avogadro constant	$N_A = 6.02 \times 10^{23} \text{ mol}^{-1}$
Boltzmann constant	$k = 1.38 \times 10^{-23} \text{ J K}^{-1}$
Stefan-Boltzmann constant	$\sigma = 5.67 \times 10^{-8} \text{ W m}^{-2} \text{ K}^{-4}$

## Formulae

uniformly accelerated motion	$s = ut + \frac{1}{2}at^2$ $v^2 = u^2 + 2as$ $s = \left(\frac{u+v}{2}\right)t$	magnetic force	$F = BIl \sin \theta$ $F = BQv \sin \theta$
heating	$\Delta E = mc\Delta\theta$	electromagnetic induction	$E = \frac{-d(N\Phi)}{dt}$
change of state	$\Delta E = mL$	Hall effect	$V = Bvd$
refraction	$n = \frac{\sin\theta_1}{\sin\theta_2}$ $n = \frac{v_1}{v_2}$	time dilation	$t' = \frac{t}{\sqrt{1 - \frac{v^2}{c^2}}}$
photon energy	$E = hf$	kinetic theory	$\frac{1}{2}m\langle c^2 \rangle = \frac{3}{2}kT$
de Broglie wavelength	$\lambda = \frac{h}{p}$	work done on/by a gas	$W = p\Delta V$
simple harmonic motion	$x = A \cos \omega t$ $v = -A\omega \sin \omega t$ $a = -A\omega^2 \cos \omega t$ $F = -m\omega^2 x$ $E = \frac{1}{2}mA^2\omega^2$	radioactive decay	$\frac{dN}{dt} = -\lambda N$ $N = N_0e^{-\lambda t}$ $t_{\frac{1}{2}} = \frac{\ln 2}{\lambda}$
energy stored in a capacitor	$W = \frac{1}{2}QV$	attenuation losses	$I = I_0e^{-\mu x}$
electric force	$F = \frac{Q_1Q_2}{4\pi\epsilon_0r^2}$	mass-energy equivalence	$\Delta E = c^2\Delta m$
electrostatic potential energy	$W = \frac{Q_1Q_2}{4\pi\epsilon_0r}$	hydrogen energy levels	$E_n = \frac{-13.6\text{eV}}{n^2}$
gravitational force	$F = \frac{-Gm_1m_2}{r^2}$	Heisenberg uncertainty principle	$\Delta p \Delta x \geq \frac{h}{2\pi}$ $\Delta E \Delta t \geq \frac{h}{2\pi}$
gravitational potential energy	$E = \frac{-Gm_1m_2}{r}$	Wien's law	$\lambda_{\max} \propto \frac{1}{T}$
		Stefan's law	$L = 4\pi\sigma r^2 T^4$
		electromagnetic radiation from a moving source	$\frac{\Delta\lambda}{\lambda} \approx \frac{\Delta f}{f} \approx \frac{v}{c}$

## Section A

You are advised to spend 1½ hours answering this section.

- 1 (a) Define *momentum*.

.....[1]

- (b) State Newton's second law and use it to show that impulse is proportional to the change in momentum.

.....  
 .....  
 .....  
 .....  
 .....  
 .....  
 .....  
 .....  
 .....  
 .....  
 ..... [2]

- (c) A cyclist is travelling due east with a velocity of  $16 \text{ m s}^{-1}$ . The cyclist changes velocity to be travelling due south with a velocity of  $12 \text{ m s}^{-1}$ .

- (i) The initial velocity of  $16 \text{ m s}^{-1}$  is shown in Fig. 1.1. On Fig. 1.1 draw the vector representing the velocity of  $12 \text{ m s}^{-1}$  and a further vector to represent the change in velocity. Your drawing does not need to be exactly to scale.

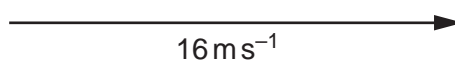

Fig. 1.1

[2]

- (ii) Calculate the change in the velocity of the cyclist.

For  
Examiner's  
Use

magnitude of change in velocity = .....  $\text{ms}^{-1}$  [2]

direction of change in velocity = ..... [1]

- (iii) The mass of the cyclist is 73 kg. Calculate the magnitude of the change in the momentum of the cyclist. Give the unit of this momentum change.

magnitude of change in momentum = ..... unit ..... [2]

[Total: 10]

- 2 The graph drawn in Fig. 2.1 shows how the force applied to a copper wire is related to the extension of the wire.

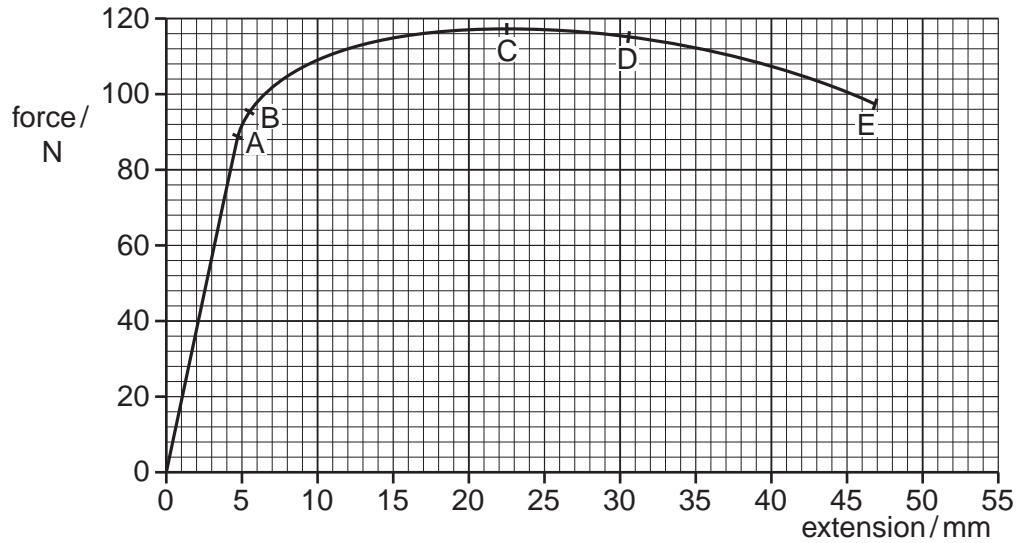

Fig. 2.1

Using information from the graph answer the following.

- (a) Give the letter that could correspond to

- (i) the breaking point, ..... [1]  
 (ii) the elastic limit, ..... [1]  
 (iii) the limit of proportionality. .... [1]

- (b) Complete the following statement.

The graph exhibits the behaviour of a ..... material. [1]

- (c) State the feature of the graph that corresponds to the work done in stretching the wire.

..... [1]

- (d) Add to the graph a line indicating the way the wire responds when, at D, the force is reduced to zero. [2]

- (e) The wire has an unstretched length of 2.40m and an area of cross-section of  $3.90 \times 10^{-7} \text{ m}^2$ . Determine the Young Modulus  $Y$  of the material.

*For  
Examiner's  
Use*

$Y = \dots\dots\dots \text{ Pa [4]}$

[Total: 11]

- 3 (a) Define resistance.

.....  
 ..... [1]

- (b) Calculate the current through a resistor of  $4.0\ \Omega$  resistance with a potential difference (p.d.) of 12V across it.

current = ..... A [1]

- (c) A car battery can be charged from a d.c. supply connected in parallel.

Fig. 3.1 is a simplified circuit diagram of such an arrangement, but with some of the electrical items in use in the car also still connected to the battery.

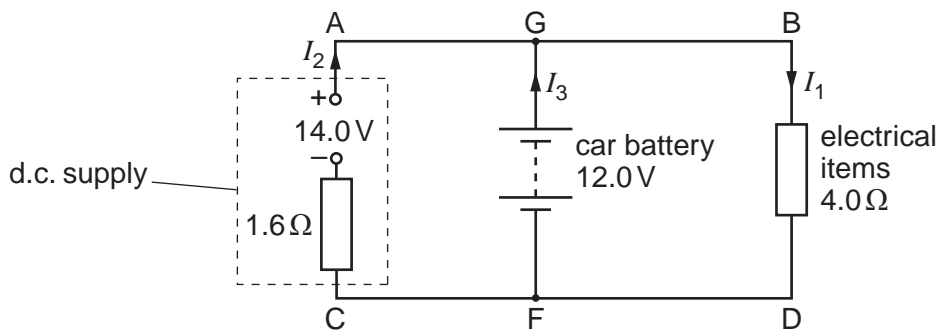

**Fig. 3.1**

The car battery has an e.m.f. of 12.0V and negligible internal resistance.  
 The d.c. supply has an e.m.f. of 14.0V and an internal resistance of  $1.6\ \Omega$ .  
 The total resistance of the electrical items in use is  $4.0\ \Omega$ .

The p.d. between the wire AB and the wire CD is the same as the p.d. between G and F, which is 12.0V.

- (i) Deduce the p.d. across the internal resistance of the d.c. supply.

p.d. = ..... V [1]



(ii) Calculate the current  $I_2$  through the d.c. supply.

$I_2 = \dots\dots\dots$  A [2]

(iii) Calculate the current  $I_3$  through the battery.

$I_3 = \dots\dots\dots$  A [1]

(d) More electrical items are switched on.

(i) Show that the total resistance of the electrical items in use in Fig. 3.1, for the battery to supply zero current, is  $9.6\ \Omega$ .

[2]

(ii) Suggest what will happen if the total resistance of the electrical items is higher than  $9.6\ \Omega$ .

.....  
..... [1]

[Total: 9]

4 (a) Explain, with the aid of a diagram, what is meant by *total internal reflection*.

.....

.....

.....

..... [3]

(b) Deduce, from the expression for refractive index, the relationship between the critical angle  $c$  and the refractive index  $n$ .

[2]

(c) An optical fibre is made of a core of very pure glass of refractive index  $n = 1.536$  for red light. It is surrounded by a cladding of refractive index  $n = 1.517$  for the same red light, as shown in Fig. 4.1.

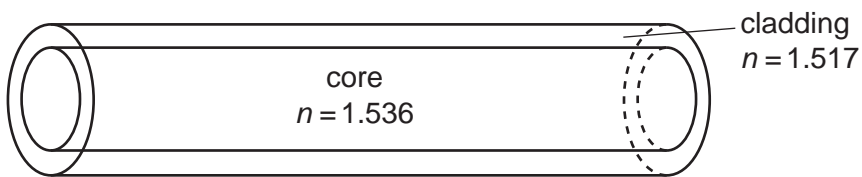

Fig. 4.1

(i) Explain why these refractive indices are stated for a specific colour of light.

.....

.....

..... [1]

- (ii) 1. Calculate the speed of the red light in the core.

speed = .....  $\text{ms}^{-1}$  [2]

2. The speed of red light in the cladding is  $1.978 \times 10^8 \text{ms}^{-1}$ . Use this value and your answer to 1 to determine the critical angle for the interface between the core and the cladding.

critical angle = .....  $^{\circ}$  [2]

- (iii) Calculate the extra distance travelled by light internally reflected within the core at this angle, compared with light travelling along the axis of a fibre of length 4.00 km.

distance = ..... m [3]

[Total: 13]

- 5 (a) Fig. 5.1 represents light of wavelength 589 nm emitted from two sources. The time axes have the same scales.

For  
Examiner's  
Use

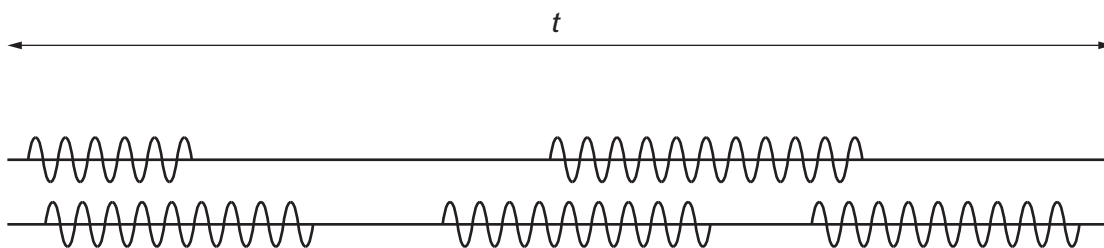

Fig. 5.1

- (i) Calculate the frequency of the light waves of wavelength 589 nm.

frequency = ..... Hz [2]

- (ii) Find the approximate value of time  $t$  shown in Fig. 5.1.

$t =$  ..... s [2]

- (iii) Explain why the light from these two sources is not coherent.

.....  
 .....  
 ..... [1]

- (iv) Explain why sources that are not coherent do not produce a visible interference pattern.

.....  
 .....  
 ..... [2]

(b) Fig. 5.2 represents three different wave patterns related to radio transmission. Waves A and B combine to form wave C.

For  
Examiner's  
Use

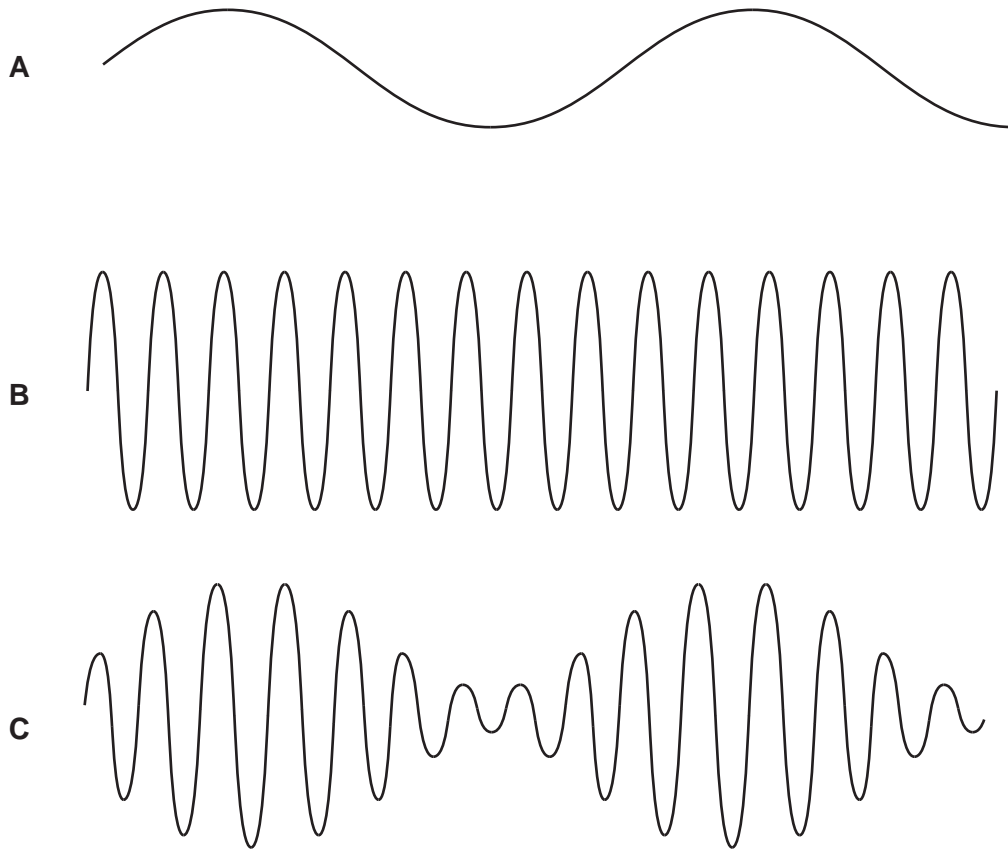

**Fig. 5.2**

State the terms used for

- (i) the low frequency wave **A**, ..... [1]
- (ii) the high frequency wave **B**, ..... [1]
- (iii) the combined wave **C**. ..... [1]

[Total: 10]

- 6 (a) Describe, with the aid of a labelled diagram, the alpha particle scattering experiment and explain its importance in determining the structure of atoms.

For  
Examiner's  
Use

.....

.....

.....

.....

.....

.....

.....

.....

.....

.....

.....

.....

.....

.....

.....

.....

.....

.....

.....

.....

..... [6]

- (b) Nuclear decay is *spontaneous* and *random*. Explain what is meant by these two terms.
- spontaneous .....
- .....
- .....
- random .....
- .....
- .....
- ..... [3]

- (c) A particular nucleus has a constant decay probability. Explain why this results in a sketch graph of number of undecayed nuclei  $N$  against time  $t$  having the shape shown in Fig. 6.1.

For  
Examiner's  
Use

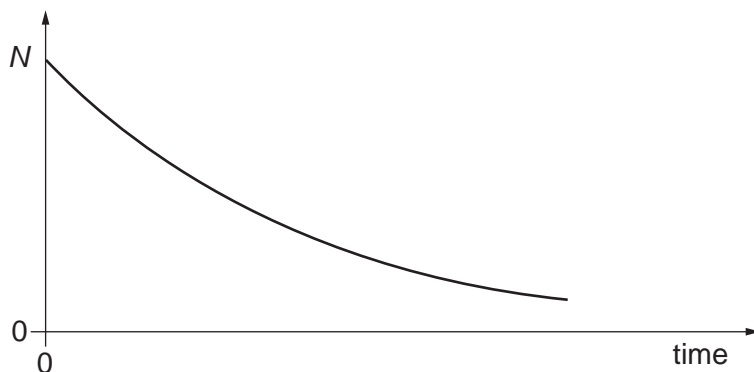

Fig. 6.1

.....

.....

.....

.....

..... [3]

- (d) A radioactive source contains  $2.40 \times 10^{15}$  nuclei. The time for the number to fall to  $1.20 \times 10^{15}$  nuclei is 693 hours. The decay probability of these nuclei is 1 in 1000 in one hour.

Calculate

- (i) the initial rate of decay per hour,

initial rate of decay = ..... per hour [2]

- (ii) the number of undecayed nuclei after 6930 hours.

number of undecayed nuclei = ..... [2]

[Total: 16]

- 7 (a) In an experiment to test the ideas of Louis de Broglie, a stream of electrons was aimed at a thin film of carbon atoms. The pattern of the electrons formed on a screen after the electrons had passed through the film is illustrated in Fig. 7.1.

For  
Examiner's  
Use

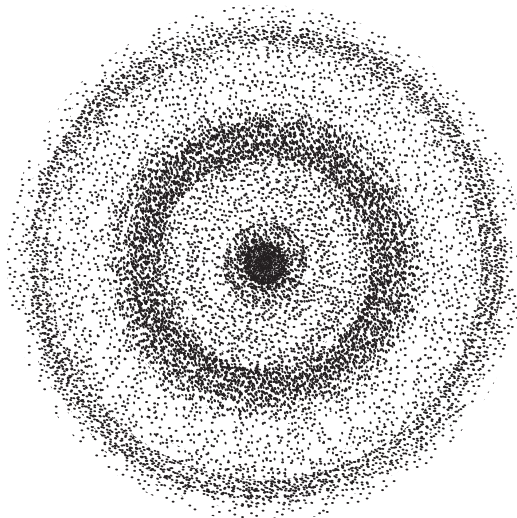

Fig. 7.1

Describe how the results of this experiment changed our understanding of the nature of the electron.

.....

.....

.....

.....

..... [3]

- (b) Calculate the de Broglie wavelength of an electron travelling with speed  $2.8 \times 10^7 \text{ m s}^{-1}$ .

wavelength = ..... m [3]

[Total: 6]



**BLANK PAGE**

**Please turn over for Section B**

## Section B

You are advised to spend about 30 minutes answering this section.  
Your answers should, where possible, make use of any relevant Physics.

- 8 (a) Fig. 8.1 shows how the current  $I$  in an a.c. transmission line varies with time  $t$ .

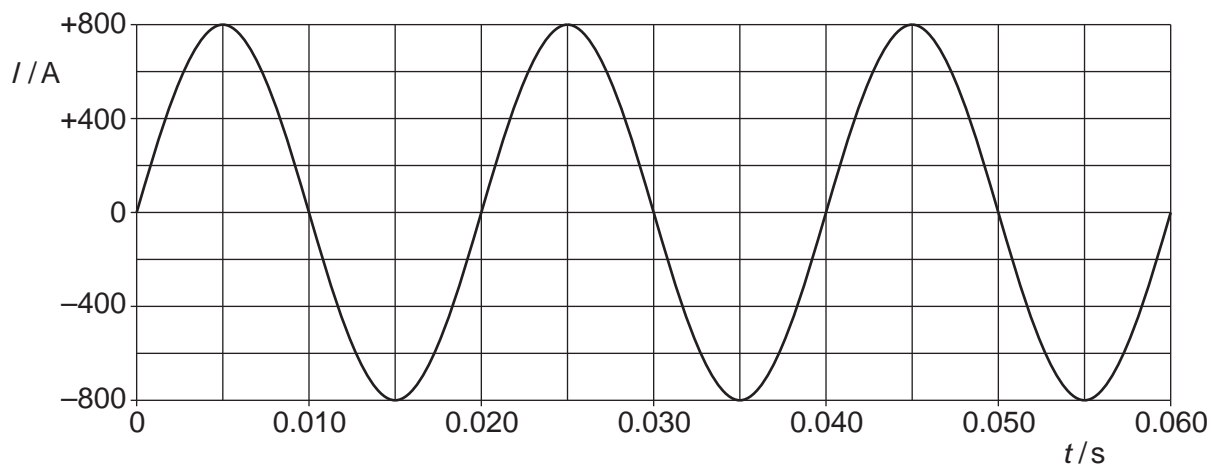

Fig. 8.1

Fig. 8.2 shows how the voltage  $V$  across the transmission line varies with time  $t$ .

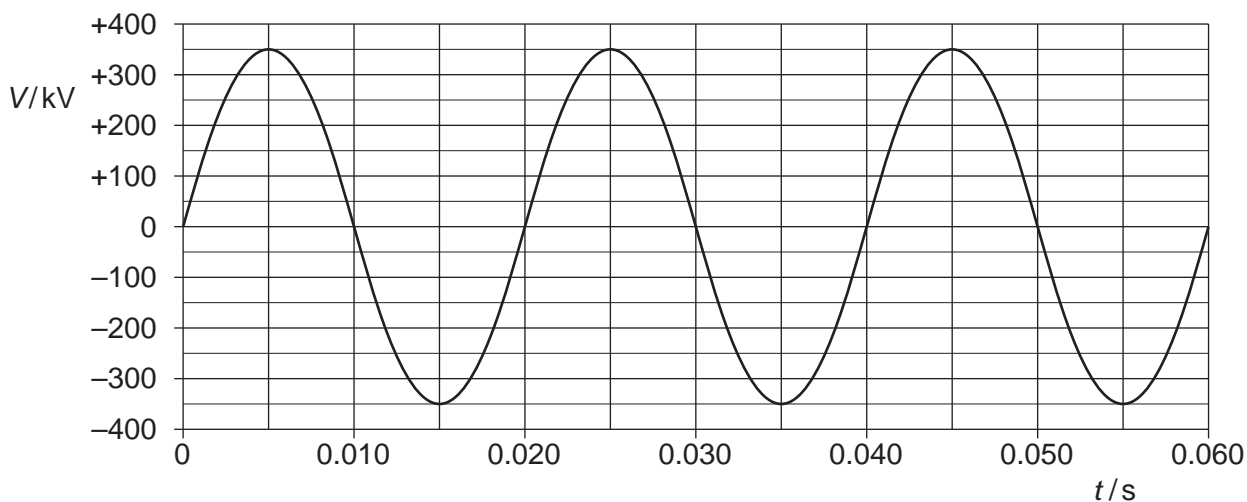

Fig. 8.2

- (i) 1. State the peak value of the current in the wire.

peak value of current = ..... A [1]

2. State the peak value, in volts, of the voltage across the wire.

peak value of voltage = ..... V [1]

(ii) Determine the power delivered by the transmission line at

1.  $t = 0.015\text{ s}$ ,

power = ..... W

2.  $t = 0.030\text{ s}$ .

power = ..... W  
[2]

(iii) Using information from (ii) and Fig. E1.1 in Extract 1, sketch a graph on the axes of Fig. 8.3 to show how the power  $P$  delivered by the transmission line varies with time. [3]

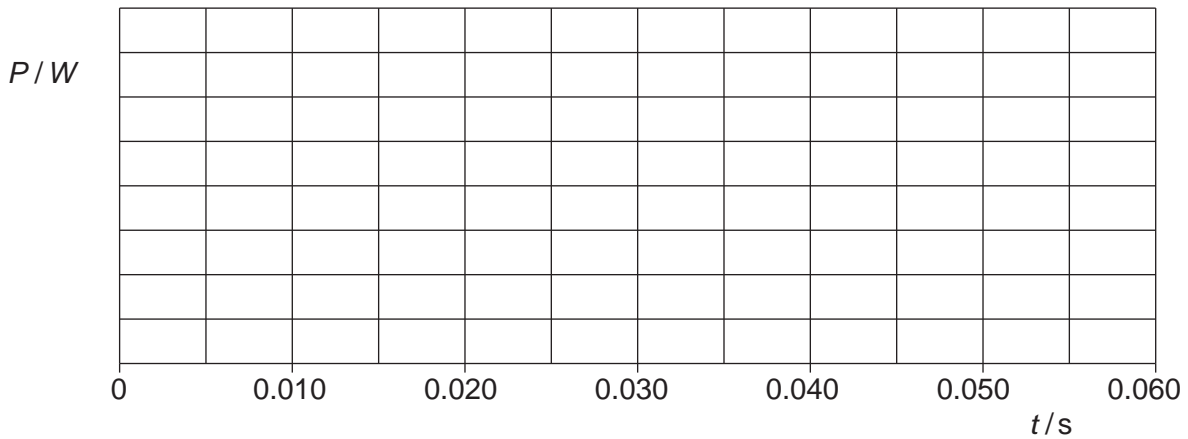

**Fig. 8.3**

(iv) It is suggested that this transmission line is used in a high voltage direct current (HVDC) transmission system delivering a current of 800 A at a constant voltage of 350 kV.

Draw a line on Fig. 8.3 to show the power that would be delivered by this HVDC line as time varies. [2]

(v) Explain how the graph you drew on Fig. 8.3 shows that the average power delivered by the HDVC transmission line would be much greater than that delivered by the line when transmitting a.c.

.....  
.....  
..... [2]

(b) A cylindrical copper wire in the transmission system has a diameter of 3.00 cm and a length of 580 km. There is an alternating current (a.c.) of frequency 50.0 Hz in the wire.

For  
Examiner's  
Use

- (i) Use information from Extract 4 to calculate the skin effect depth for the wire when it carries this current.

skin effect depth = ..... m [1]

- (ii) Assume that when there is an alternating current in the cylindrical copper wire, the current flows only in the region between the surface of the wire and a depth equal to the skin effect depth and there is no current at the centre of the cylindrical wire.

Use the value from **(b)(i)** to calculate the cross-sectional area of the region of the wire in which this current flows.

cross-sectional area = ..... m<sup>2</sup> [2]

- (iii) The resistivity of copper is  $1.72 \times 10^{-8} \Omega \text{ m}$ . Calculate the resistance of the wire for this current.

resistance = .....  $\Omega$  [2]

- (iv) The peak value of the a.c. in the wire is 800 A. Calculate the maximum rate at which heat (thermal energy) is generated in the wire. Express the answer in megawatts.

heat (thermal energy) = ..... MW [2]







**BLANK PAGE**

---

*Copyright Acknowledgements:*

- Extract 1     © [http://www.practicalphysics.org/go/Guidance\\_107.html](http://www.practicalphysics.org/go/Guidance_107.html).  
Extract 2     © <http://www.abb.com/industries/us/9AAC30300393.aspx>.  
Extract 3     © [http://en.wikipedia.org/wiki/High-voltage\\_direct\\_current](http://en.wikipedia.org/wiki/High-voltage_direct_current).  
Extract 4     © <http://www.calculatoredge.com/electronics/skin%20effect.htm>.  
Extract 5     © [http://en.wikipedia.org/wiki/High-voltage\\_direct\\_current](http://en.wikipedia.org/wiki/High-voltage_direct_current).

Permission to reproduce items where third-party owned material protected by copyright is included has been sought and cleared where possible. Every reasonable effort has been made by the publisher (UCLES) to trace copyright holders, but if any items requiring clearance have unwittingly been included, the publisher will be pleased to make amends at the earliest possible opportunity.

University of Cambridge International Examinations is part of the Cambridge Assessment Group. Cambridge Assessment is the brand name of University of Cambridge Local Examinations Syndicate (UCLES), which is itself a department of the University of Cambridge.