



CHEMISTRY

9791/01

Paper 1 Part A Multiple Choice

May/June 2010

1 hour

Additional Materials: Multiple Choice Answer Sheet
 Soft clean eraser
 Soft pencil (type B or HB is recommended)
 Data Booklet



READ THESE INSTRUCTIONS FIRST

Write in soft pencil.

Do not use staples, paper clips, highlighters, glue or correction fluid.

Write your name, Centre number and candidate number on the Answer sheet in the spaces provided unless this has been done for you.

There are 40 questions on this paper. Answer **all** questions. For each question there are four possible answers **A, B, C** and **D**.

Choose the **one** you consider correct and record your choice in **soft pencil** on the separate Answer Sheet.

Read the instructions on the Answer Sheet very carefully.

Each correct answer will score one mark. A mark will not be deducted for a wrong answer.

Any rough working out should be done in this booklet.

This document consists of **14** printed pages and **2** blank pages.



- 1 Which statement about an element in the Periodic Table is correct?
- A** Magnesium is a metalloid, has a giant structure and is a good conductor of electricity.
- B** Silicon is a metalloid, has a simple molecular structure and is a semi-conductor of electricity.
- C** Sodium is a metal, has a giant structure and is a good conductor of electricity.
- D** Sulfur is a non-metal, has a giant structure and is a poor conductor of electricity.
- 2 The hydrolysis of S_2Cl_2 proceeds by two reactions.

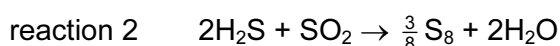
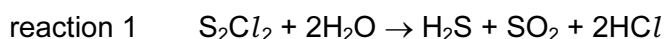

Which row correctly describes the two reactions?

| | reaction 1 | reaction 2 |
|----------|-------------------------|----------------------------|
| A | acidic solution formed | disproportionation |
| B | acidic solution formed | reverse disproportionation |
| C | neutral solution formed | disproportionation |
| D | neutral solution formed | reverse disproportionation |

- 3 During the electrolysis of molten aluminium oxide, Al^{3+} ions are converted to aluminium metal at the cathode.

How many electrons are required to produce 81.0 g of aluminium?
[L = the Avogadro constant]

- A** 9L **B** 3L **C** L **D** $\frac{L}{3}$

- 4 Which atom has the highest ratio of unpaired electrons to paired electrons in its ground state?
- A** boron
- B** carbon
- C** nitrogen
- D** oxygen

- 5 The double salt $(\text{NH}_4)_2\text{SO}_4 \cdot \text{FeSO}_4 \cdot 6\text{H}_2\text{O}$ is used as a standard in volumetric analysis for titrations with oxidising agents.

What is the electronic configuration of the metal ion in this salt?

- A $[\text{Ar}]4s^23d^6$ B $[\text{Ar}]4s^23d^4$ C $[\text{Ar}]3d^6$ D $[\text{Ar}]3d^5$

- 6 Which sequence of first ionisation energies for the elements of the third period is correct?

| | energies / kJ mol^{-1} | | | | | | | |
|---|---------------------------------|-----|-----|-----|------|------|------|------|
| | Na | Mg | Al | Si | P | S | Cl | Ar |
| A | 496 | 578 | 738 | 789 | 1000 | 1060 | 1251 | 1521 |
| B | 496 | 738 | 578 | 789 | 1000 | 1060 | 1251 | 1521 |
| C | 496 | 578 | 738 | 789 | 1012 | 1000 | 1251 | 1521 |
| D | 496 | 738 | 578 | 789 | 1012 | 1000 | 1251 | 1521 |

- 7 Which shows the chemical bonds in order of increasing bond length?

- A $\text{Cl}-\text{Cl}$ $\text{F}-\text{F}$ $\text{O}=\text{O}$ $\text{N}\equiv\text{N}$
 B $\text{F}-\text{F}$ $\text{Cl}-\text{Cl}$ $\text{O}=\text{O}$ $\text{N}\equiv\text{N}$
 C $\text{N}\equiv\text{N}$ $\text{O}=\text{O}$ $\text{Cl}-\text{Cl}$ $\text{F}-\text{F}$
 D $\text{N}\equiv\text{N}$ $\text{O}=\text{O}$ $\text{F}-\text{F}$ $\text{Cl}-\text{Cl}$

- 8 Which statement about bond formation is **not** correct?

- A A triple bond consists of one σ bond and two π bonds.
 B A π bond restricts rotation about the σ bond axis.
 C Bonds formed from atomic s orbitals are always σ bonds.
 D End-to-end orbital overlap results in a bond with electron density above and below the bond axis.

- 9 The diagram represents the energy changes for some reactions.

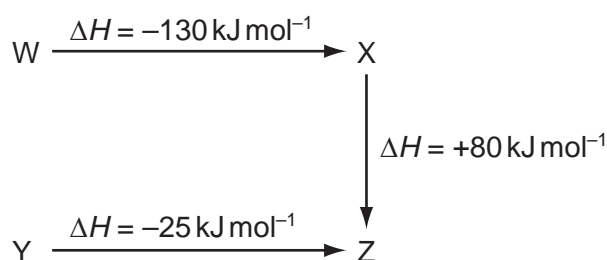

What are the natures of the conversions $W \rightarrow Y$, $Y \rightarrow X$ and $Z \rightarrow W$?

| | $W \rightarrow Y$ | $Y \rightarrow X$ | $Z \rightarrow W$ |
|----------|-------------------|-------------------|-------------------|
| A | exothermic | endothermic | endothermic |
| B | exothermic | exothermic | endothermic |
| C | endothermic | exothermic | exothermic |
| D | endothermic | endothermic | exothermic |

- 10 The diagram shows the energy profile for a reaction both with and without a catalyst present.

What is the activation energy of the uncatalysed reverse reaction?

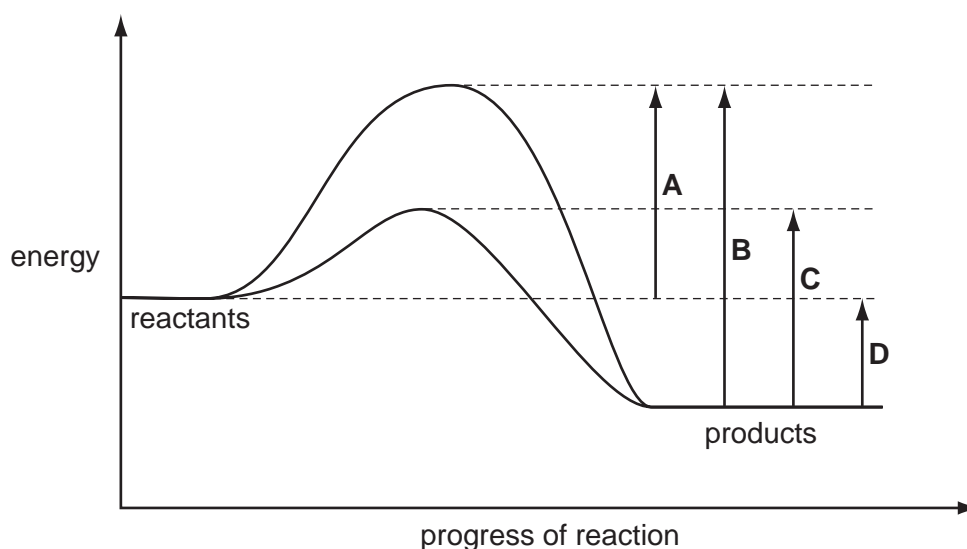

- 11 The metal niobium, Nb, has a relative atomic mass of 92.9 and is used in various stainless steel alloys. It is made by reducing niobium chloride with sodium. In this reaction, 54.08 g of niobium chloride produces 18.58 g of niobium.

What is the formula of the niobium chloride used?

- A** NbCl_2 **B** NbCl_3 **C** NbCl_4 **D** NbCl_5

12 Many compounds containing lithium, such as lithium chloride, have pharmacological uses.

The diagram shows the Born-Haber cycle showing the formation of lithium chloride.

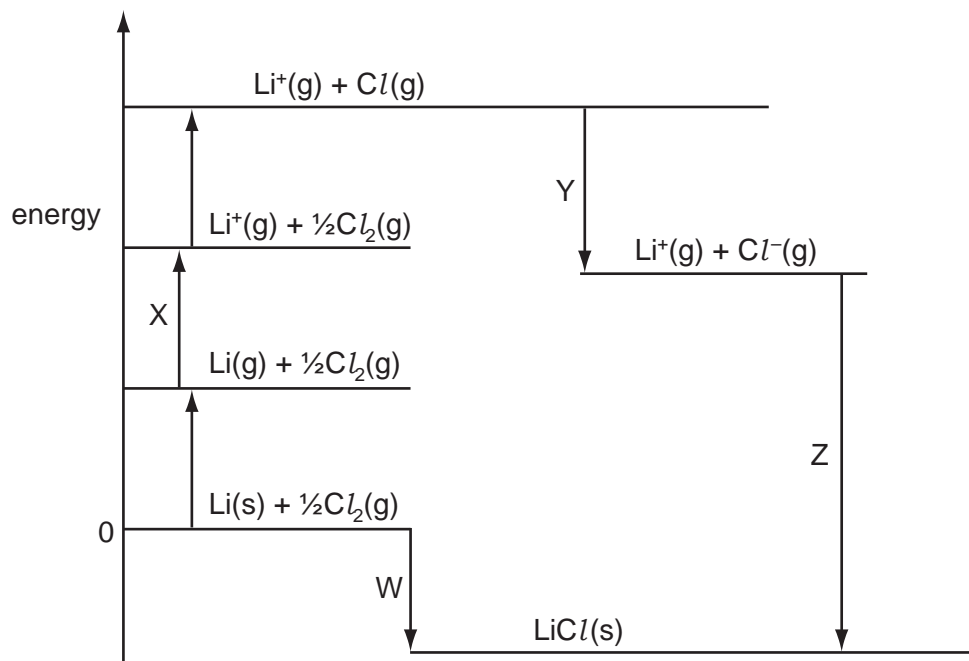

What are the correct names of the four steps W, X, Y and Z?

| | W | X | Y | Z |
|----------|-----------------------|-------------------------|-------------------------|-----------------------|
| A | enthalpy of formation | ionisation energy | enthalpy of atomisation | lattice energy |
| B | enthalpy of formation | ionisation energy | electron affinity | lattice energy |
| C | lattice energy | enthalpy of atomisation | electron affinity | enthalpy of formation |
| D | lattice energy | enthalpy of atomisation | ionisation energy | enthalpy of formation |

13 A protonated oxoanion of vanadium has been characterised at pH3 with the formula $\text{HV}_{10}\text{O}_{28}^{5-}$.

Which oxoanion contains vanadium in a **different** oxidation state from that shown in $\text{HV}_{10}\text{O}_{28}^{5-}$?

- A** VO_2^+ **B** VO^{2+} **C** $\text{V}_4\text{O}_{12}^{4-}$ **D** VO_4^{3-}

14 Four compounds of period 3 elements are listed.



Water is added to each of the four compounds.

Pairs of the resulting solutions are mixed together.

From which pair of solutions is it possible to get a solution with a pH of 7?

- A NaCl and Na_2O
- B NaCl and SO_2
- C Na_2O and SiCl_4
- D SiCl_4 and SO_2

15 In Group 2, what are the trends in charge density of the metal cations and thermal stability of the metal carbonates as the atomic number of the metal increases?

| | charge density | thermal stability |
|---|----------------|-------------------|
| A | decreases | decreases |
| B | decreases | increases |
| C | increases | decreases |
| D | increases | increases |

16 The diagram shows bond energies in halogen molecules.

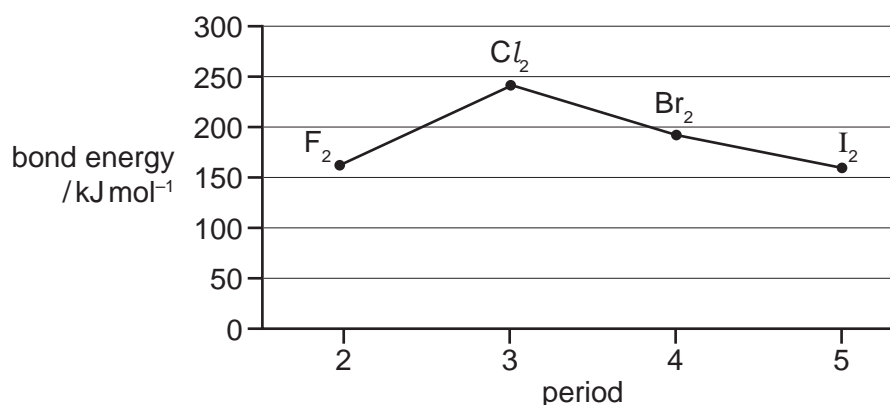

Why does the value for fluorine **not** follow the trend shown by chlorine, bromine and iodine?

- A Fluorine is more electronegative than the other halogens.
- B Lone electron pairs in fluorine repel more strongly than those in the other halogens.
- C The bonds in fluorine are more polar than those in the other halogens.
- D The bonds in fluorine have some π -character.

17 Which statement about the element astatine (atomic number 85) is **not** correct and is **not** consistent with its position in Group 17?

- A Astatine is a product of the reaction between sodium astatide and concentrated sulfuric acid.
- B Astatine is a solid at room temperature and pressure.
- C Silver astatide is soluble in aqueous ammonia.
- D The bond energy of hydrogen astatide is less than that of hydrogen iodide.

18 In the gas phase, ammonia reacts with chlorine.

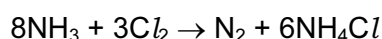

Which row indicates the correct combination of statements about this reaction?

| | ammonia acts as a reducing agent | ammonia acts as a base | a dative bond is formed |
|----------|----------------------------------|------------------------|-------------------------|
| A | ✓ | ✓ | ✓ |
| B | ✓ | ✗ | ✗ |
| C | ✗ | ✓ | ✓ |
| D | ✗ | ✗ | ✓ |

19 Sulfuric acid, one of the most important industrial chemicals, can carry out several functions in chemical reactions.

Three examples of industrial reactions in which sulfuric acid is used are shown below.

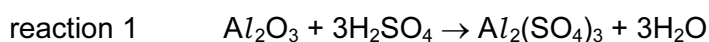

What is the function of sulfuric acid in each reaction?

| | reaction 1 | reaction 2 | reaction 3 |
|----------|-------------|------------|-------------|
| A | acidic | oxidising | dehydrating |
| B | acidic | acidic | dehydrating |
| C | dehydrating | oxidising | catalytic |
| D | dehydrating | acidic | catalytic |

20 An organic molecule contains

- only carbon, hydrogen and one oxygen atom;
- one carbon atom at the carbonyl functional group level;
- one asymmetric carbon atom.

What is the smallest number of carbon atoms such a molecule could possess?

- A 4 B 5 C 6 D 7

21 The diagram shows the structure of propofol, a short-acting intravenous anaesthetic used for both adults and children, and also in veterinary medicine.

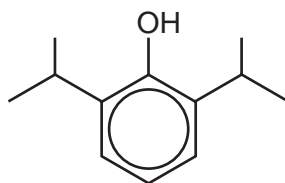

When reacted with a very dilute solution of Cl_2 a chlorine atom may substitute for a hydrogen atom on the benzene ring but **not** for a hydrogen atom on the alkyl branches or in the $-\text{OH}$ group.

Given that any number of the benzene hydrogens may be substituted, how many possible products of the reaction are there?

- A 3 B 4 C 5 D 6

22 Which pair of reactions could **not** regenerate the original organic reactant?

- A addition followed by elimination
- B addition followed by substitution
- C hydrolysis followed by substitution
- D substitution followed by hydrolysis

23 Partial hydrolysis of an animal protein produces a dipeptide with the structure shown.



How many carbon atoms, at the functional group levels shown, does this molecule possess?

| | alcohol | carbonyl | carboxylic acid |
|---|---------|----------|-----------------|
| A | 1 | 1 | 2 |
| B | 2 | 0 | 2 |
| C | 2 | 1 | 1 |
| D | 3 | 0 | 1 |

24 How many of the structural isomers of dibromopropane will react with aqueous sodium hydroxide to produce a compound with a carbon atom at the carbonyl functional group level?

- A 0 B 1 C 2 D 3

25 Which conversion involves an increase in bond angle in the molecule involved and a decrease in functional group level of a carbon atom?

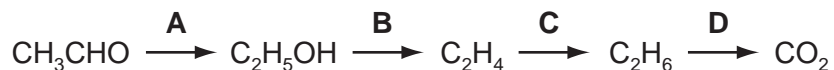

26 Which sequence shows an **overall** change that moves a carbon atom up one functional group level?

- A $\text{CH}_3\text{CH}_2\text{CH}_2\text{Br} \rightarrow \text{CH}_3\text{CH}_2\text{CH}_2\text{OH} \rightarrow \text{CH}_3\text{CH}_2\text{CO}_2\text{H}$
 B $\text{CH}_3\text{CH}_2\text{CH}_2\text{Br} \rightarrow \text{CH}_3\text{CH}_2\text{CH}_2\text{NH}_2 \rightarrow \text{CH}_3\text{CH}_2\text{CH}_2\text{CN}$
 C $\text{CH}_3\text{CH}_2\text{CH}_3 \rightarrow \text{CH}_3\text{CH}_2\text{CH}_2\text{Br} \rightarrow \text{CH}_3\text{CH}_2\text{CH}_2\text{NH}_2$
 D $\text{CH}_3\text{CH}_2\text{CH}_3 \rightarrow \text{CH}_3\text{CH}=\text{CH}_2 \rightarrow 3\text{CO}_2 + 3\text{H}_2\text{O}$

27 An organic compound X is reacted with an ethanolic solution of cyanide ions to form compound Y. Y is hydrolysed in acid solution to form compound Z, a carboxylic acid.

Which statement is correct?

- A X is an alcohol with the same number of carbon atoms in one molecule as Z.
 B X is an alcohol with fewer carbon atoms in its molecule than Z.
 C X is a halogenoalkane with the same number of carbon atoms in one molecule as Z.
 D X is a halogenoalkane with fewer carbon atoms in its molecule than Z.

28 One of the chemicals giving blue cheese its unique aroma is heptan-2-one.

The diagram shows reactions involving heptan-2-one.

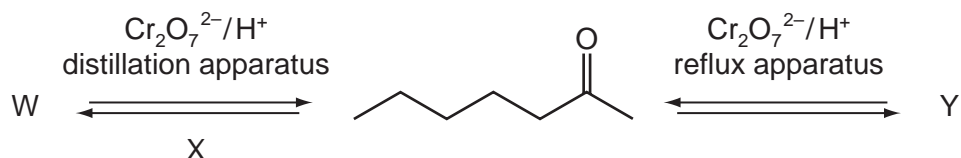

Which row correctly identifies compound W, reagent X and compound Y?

| | compound W | reagent X | compound Y |
|----------|-------------|------------------------------------|----------------|
| A | heptane | NaBH ₄ | heptanoic acid |
| B | heptan-2-ol | NaBH ₄ | heptanoic acid |
| C | heptanal | C ₂ H ₅ MgBr | heptan-2-one |
| D | heptan-2-ol | NaBH ₄ | heptan-2-one |

29 The diagram shows a molecule of propenal, which is used to make many polymers.

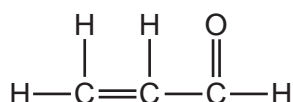

When CH₃MgBr reacts with propenal, which bond in the above molecule is broken?

- A** the σ bond in C=O
 - B** the σ bond in C=C
 - C** the π bond in C=O
 - D** the π bond in C=C
- 30 What causes carbonyl groups, C=O, to react by a nucleophilic mechanism while alkene groups, C=C, react by an electrophilic mechanism?
- A** oxygen is more reactive than carbon
 - B** the different lengths of the double bonds
 - C** the electronegativity difference between the carbon and oxygen atoms in the carbonyl group
 - D** the relative strengths of the double bonds

31 Ibuprofen is an over-the-counter pain killer. There are a number of ways to synthesise the drug.

The first step in the synthesis of ibuprofen involves the production of compound T by either reaction 1 or reaction 2.

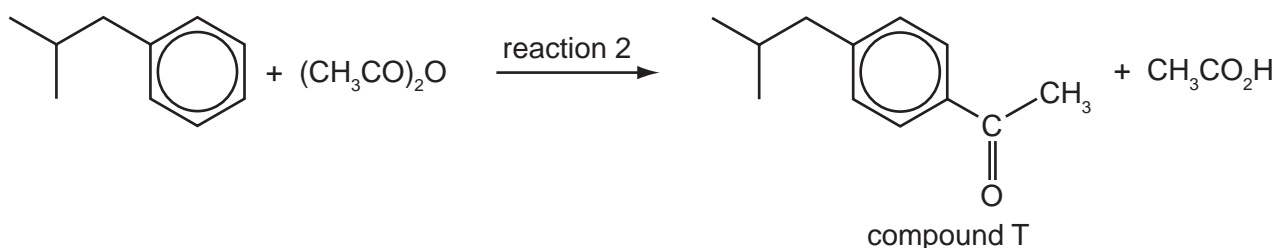
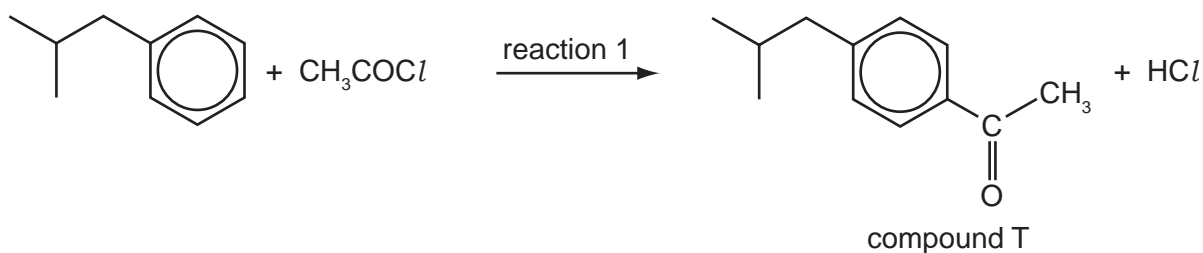

Assuming compound T is the only utilised product, which statement is correct?

- A Adding a catalyst to either reaction will increase its atom economy.
- B Reaction 1 has a higher atom economy than reaction 2.
- C Reaction 2 has a higher atom economy than reaction 1.
- D Since both reactions use the same starting material, and the utilised product is the same in both cases, there is no difference in atom economy.

32 The diagram shows some reactions of salt Q.

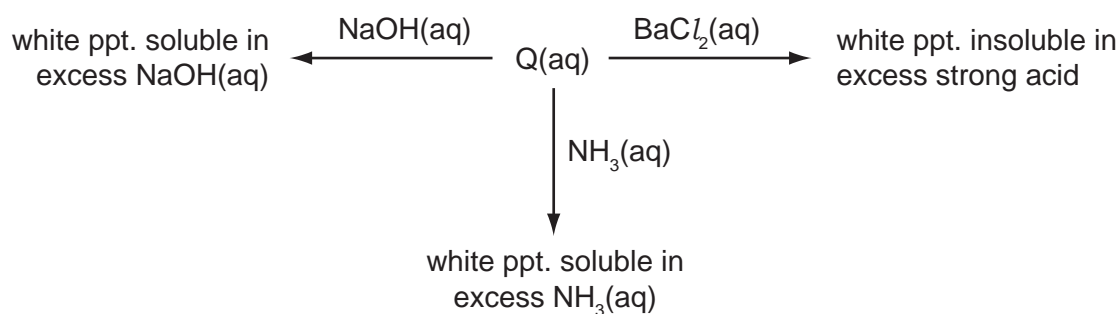

What is the identity of Q?

- A $\text{Al}_2(\text{SO}_4)_3$
- B PbSO_4
- C ZnSO_3
- D ZnSO_4

33 12.5 cm³ of 0.0500 mol dm⁻³ sodium hydroxide is added to 25.0 cm³ of 0.100 mol dm⁻³ hydrochloric acid.

Which concentration of hydrochloric acid remains in the reaction mixture?

- A 0.0019 mol dm⁻³
- B 0.0333 mol dm⁻³
- C 0.0500 mol dm⁻³
- D 0.0750 mol dm⁻³

34 Which mixture of gaseous oxygen and nitrogen would occupy 0.12 dm³ at room temperature and pressure?

- A 0.032 g O₂ and 0.084 g N₂
- B 0.096 g O₂ and 0.028 g N₂
- C 0.096 g O₂ and 0.056 g N₂
- D 0.096 g O₂ and 0.084 g N₂

35 The mass spectrum of CH₂F₂ would **not** contain a peak at which m/z value?

- A 14
- B 19
- C 38
- D 52

36 In the absence of reference spectra, infra-red spectroscopy can most easily be used to distinguish between

- A 1-chloropropane and 1-bromopropane.
- B cis but-2-ene and trans but-2-ene.
- C ethanol and ethanal.
- D propan-2-ol and propan-1-ol.

37 The diagram shows part of a simplified emission spectrum of hydrogen.

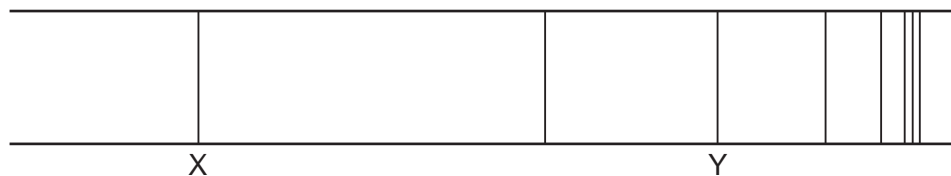

Which statement about the lines X and Y is correct?

- A The energy of line Y is greater than the energy of line X but the frequencies are the same.
- B The energy of line Y is lower than the energy of line X.
- C The frequency of line Y is lower than the frequency of line X.
- D X and Y are caused by transitions to the same energy level.

38 The diagram shows a simplified mass spectrum for pentan-3-one.

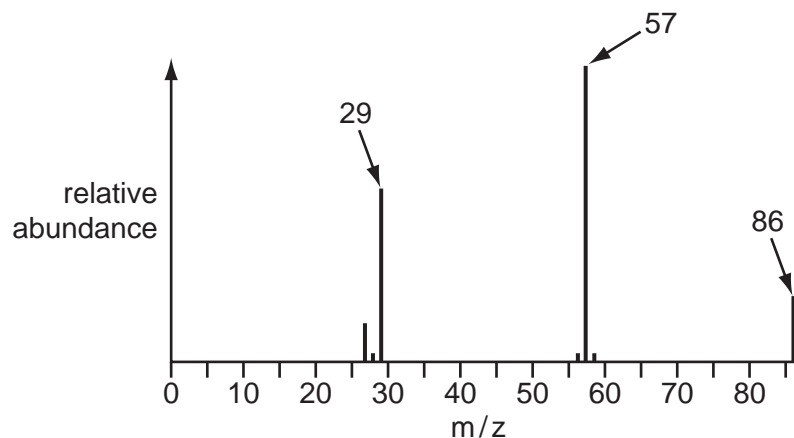

Which equation represents the process that produces the particle responsible for the peak at m/z 57?

- A $\text{CH}_3\text{CH}_2\text{COCH}_2\text{CH}_3^{\bullet+} \rightarrow \text{CH}_3\text{CH}_2\text{CO}^+ + \bullet\text{CH}_2\text{CH}_3$
- B $\text{CH}_3\text{CH}_2\text{COCH}_2\text{CH}_3^{\bullet+} \rightarrow \text{CH}_3\text{CH}_2\text{CO}^\bullet + ^+\text{CH}_2\text{CH}_3$
- C $\text{CH}_3\text{CH}_2\text{COCH}_2\text{CH}_3^{\bullet+} \rightarrow \text{CH}_3\text{CH}_2\text{CH}_2\text{CH}_2^\bullet + ^+\text{CHO}$
- D $\text{CH}_3\text{CH}_2\text{COCH}_2\text{CH}_3^{\bullet+} \rightarrow \text{CH}_3\text{CH}_2\text{CH}_2\text{CH}_2^+ + \bullet\text{CHO}$

39 An organic compound has the empirical formula C_2H_4O .

The diagram shows the infra-red spectrum of the compound.

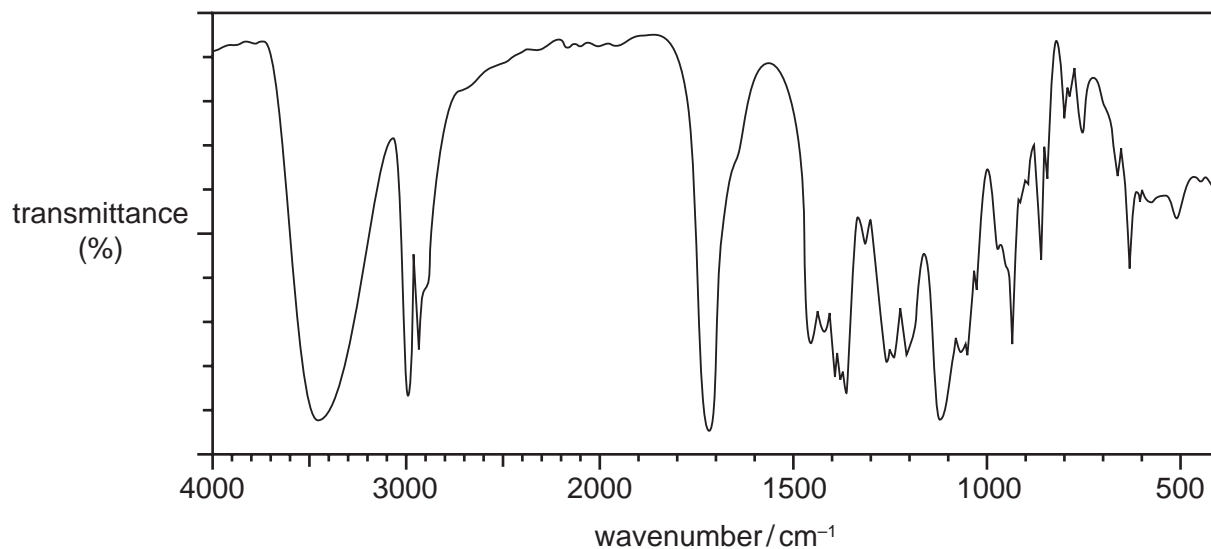

What is the structural formula of this compound?

- A CH_3CHO
- B $C_3H_7CO_2H$
- C $HCO_2C_3H_7$
- D $CH_3COCH(OH)CH_3$

40 The diagram shows the ^{13}C NMR spectrum of an alcohol of formula $C_4H_{10}O$.

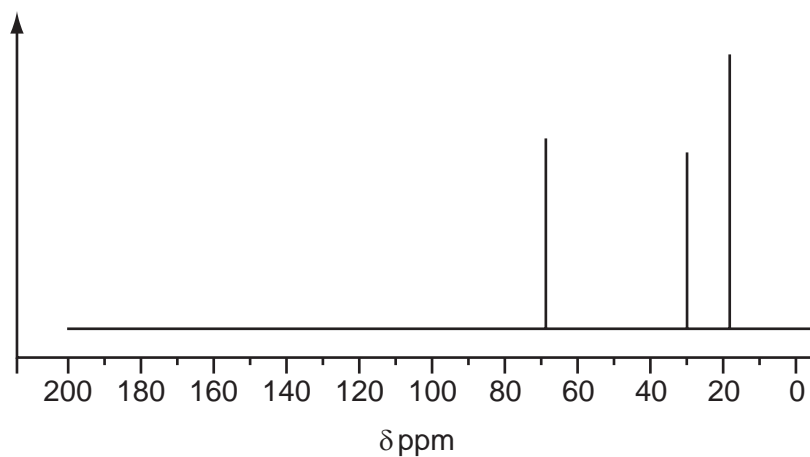

What is the alcohol?

- A butan-1-ol
- B butan-2-ol
- C 2-methylpropan-2-ol
- D 2-methylpropan-1-ol

BLANK PAGE

BLANK PAGE

Permission to reproduce items where third-party owned material protected by copyright is included has been sought and cleared where possible. Every reasonable effort has been made by the publisher (UCLES) to trace copyright holders, but if any items requiring clearance have unwittingly been included, the publisher will be pleased to make amends at the earliest possible opportunity.

University of Cambridge International Examinations is part of the Cambridge Assessment Group. Cambridge Assessment is the brand name of University of Cambridge Local Examinations Syndicate (UCLES), which is itself a department of the University of Cambridge.